

M62398P,FP

8BIT 12CH I²C BUS D-A CONVERTER WITH BUFFER AMPLIFIERS

GENERAL DESCRIPTION

The M62398P,FP is a 12V type CMOS 12-channel D-A converters with output buffer amplifiers.

It can communicate with a microcontroller via few wiring thanks to the adoption of the two-line I²C BUS.

The output buffer amplifier employs AB class output with sinking and sourcing capability of more than 2.5mA ,and an output voltage range is nearly between ground and VrefU.

Maximum 8 ICs can be connected to a bus by using three chip-set pins , so that it is possible to handle up to 96 channels.

FEATURES

- I²C BUS serial data method
- Wide output range
Nearly between ground and VrefU(0~12V).
- High output current drive capability
Over ±2.5mA
- 2 setting voltage ranges by dual input pins for upper voltage references (VrefU1,U2)

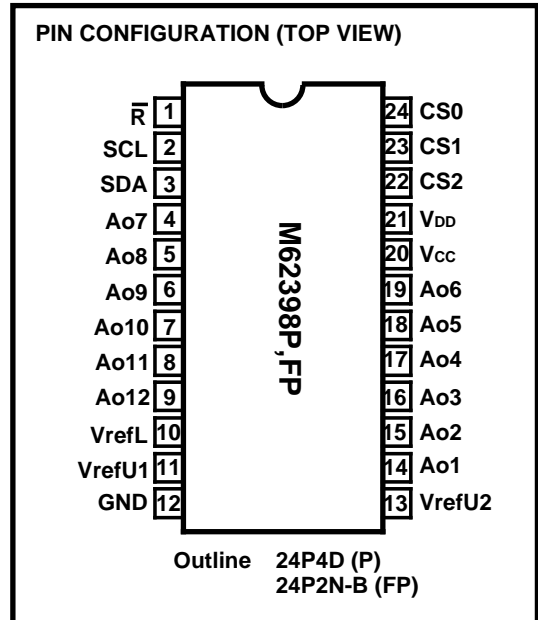

APPLICATION

Conversion from digital control data to analog control data for both consumer and industrial equipment.
Gain control and automatic adjustment of DISPLAY-MONITOR or CTV.

BLOCK DIAGRAM

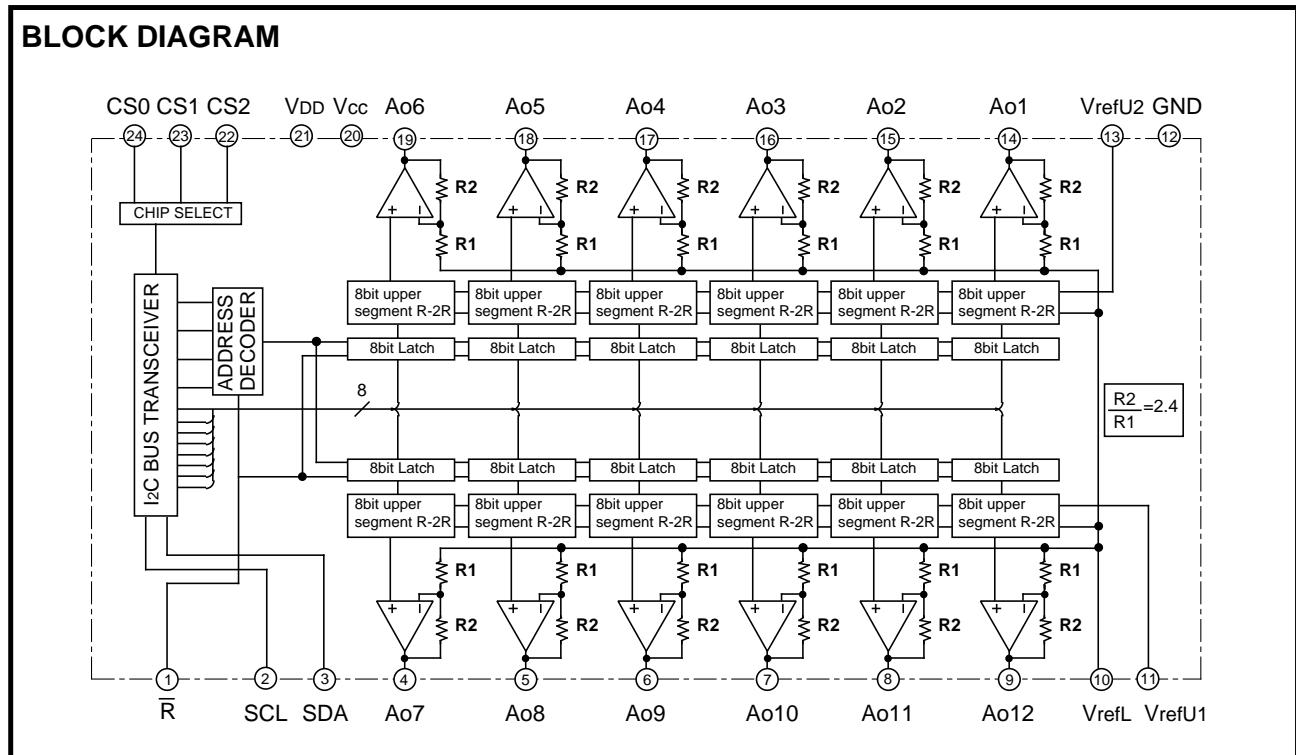

M62398P,FP

8BIT 12CH I²C BUS D-A CONVERTER WITH BUFFER AMPLIFIERS

EXPLANATION OF TERMINALS

PIN No.	Symbol	Function
③	SDA	Serial data input terminal
①	\bar{R}	Reset signal input terminal
②	SCL	Serial clock input terminal
⑭	Ao1	} 8bit D-A converter output terminal
⑮	Ao2	
⑯	Ao3	
⑰	Ao4	
⑱	Ao5	
⑲	Ao6	
④	Ao7	
⑤	Ao8	
⑥	Ao9	
⑦	Ao10	
⑧	Ao11	
⑨	Ao12	
⑳	VCC	Analog power supply terminal
㉑	VDD	Digital power supply terminal
⑫	GND	Analog and digital common GND
⑩	VrefL	D-A converter low level reference voltage input terminal
⑪	VrefU1	D-A converter high level reference voltage input terminal 1
⑬	VrefU2	D-A converter high level reference voltage input terminal 2
㉒	CS2	Chip select data input terminal 2
㉓	CS1	Chip select data input terminal 1
㉔	CS0	Chip select data input terminal 0

M62398P,FP

8BIT 12CH I²C BUS D-A CONVERTER WITH BUFFER AMPLIFIERS

ABSOLUTE MAXIMUM RATINGS

Symbol	Parameter	Conditions	Ratings	Unit
V _{CC}	Supply voltage		-0.3~13.5	V
V _{DD}	Supply voltage		-0.3~7.0	V
V _{refU1,2}	D-A converter upper reference voltage		V _{DD}	V
V _{IND}	Digital input voltage		-0.3~V _{DD} +0.3	V
P _d	Power dissipation		465(DIP) /421(FP)	mW
T _{opr}	Operating temperature		-20~85	°C
T _{stg}	Storage temperature		-40~125	°C

ELECTRIC CHARACTERISTICS

< Digital part > (V_{CC}=13V, V_{DD}=V_{ref U1,2}+5V±10%, GND=V_{refL}=0V, T_a=-20~85°C, unless otherwise noted)

Symbol	Parameter	Test conditions	Ratings			Unit
			MIN	TYP	MAX	
V _{DD}	Supply voltage		4.5	5.0	5.5	V
I _{DD}	Supply current	CLK=1MHz operation I _{AO} =0μA			1	mA
I _{ILK}	Input leak current	V _{IN} =0~V _{DD}	-10		10	μA
V _{IL}	Input low voltage				0.2V _{DD}	V
V _{IH}	Input high voltage		0.8V _{DD}			V

< Analog part > (V_{CC}=13V, V_{DD}=V_{refU1,2}+5V±10%, GND=V_{refL}=0V, T_a=-20~85°C, unless otherwise noted)

Symbol	Parameter	Test conditions	Ratings			Unit
			MIN	TYP	MAX	
V _{CC}	Supply voltage		2.4V _{DD}		13	V
I _{CC}	Supply current	CLK=1MHz Operation I _{AO} =0μA		2.0	4.0	mA
I _{refU}	D-A converter upper reference voltage input current	V _{refU} =5V, V _{refL} =0V Data condition: at maximum current		1.2	2.5	mA
V _{refU}	D-A converter upper reference voltage range	The output dose not necessarily be the values within the reference voltage setting range.	3.5		V _{DD}	V
V _{refL}	D-A converter lower reference voltage range		GND		1.5	V
V _{AO}	Buffer amplifier output voltage range	I _{AO} =±500μA	0.1		V _{CC} -0.1	V
		I _{AO} =±1.0mA	0.2		V _{CC} -0.2	V
I _{AO}	Buffer amplifier output drive range	Upper side saturation voltage=0.3V Lower side saturation voltage=0.2V	-2.5		2.5	mA
SDL	Differential nonlinearity error	V _{refU} =4.79V V _{refL} =0.95V V _{CC} =13V(36mV/LSB) without load (I _{AO} =0)	-1.0		1.0	LSB
SL	Nonlinearity error		-1.5		1.5	LSB
SZERO	Zero code error		-2.0		2.0	LSB
SFULL	Full scale error		-2.0		2.0	LSB
SR	Output slew rate				0.2	V/μs

M62398P,FP

8BIT 12CH I²C BUS D-A CONVERTER WITH BUFFER AMPLIFIERS

I2C BUS LINE CHARACTERISTICS

Symbol	Parameter	Normal mode		High speed mode		units
		Min.	Max.	Min.	Max.	
f _{SCL}	SCL clock frequency	0	100	0	400	KHz
t _{BUF}	Time the bus must be free before a new transmission can start	4.7	-	1.3	-	μs
t _{HD:STA}	Hold time START Condition. After this period, the first clock pulse is generated.	4.0	-	0.6	-	μs
t _{LOW}	LOW period of the clock	4.7	-	1.3	-	μs
t _{HIGH}	High period of the clock	4.0	-	0.6	-	μs
t _{SU:STA}	Set-up time for START condition (Only relevant for a repeated START condition)	4.7	-	4.7	-	μs
t _{HD:DAT}	Hold time DATA	0	-	0	0.9	μs
t _{SU:DAT}	Set-up time DATA	250	-	100	-	ns
t _R	Rise time of both SDA and SCL lines	-	1000	20+	300	ns
t _F	Fall time of both SDA and SCL lines	-	300	20+	300	ns
t _{SU:STO}	Set-up time for STOP condition	4.0	-	0.6	-	μs

*Note that a transmitter must internally provide at least a hold time to bridge the undefined region (max.300 ns) of the falling edge of SCL.

TIMING CHART

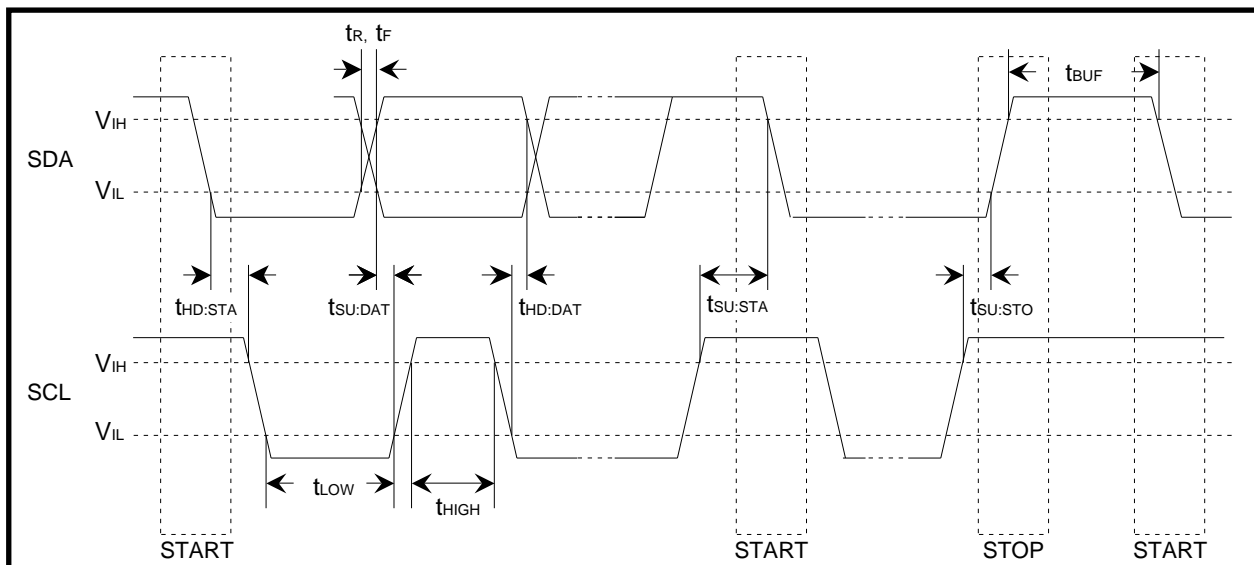

M62398P,FP

8BIT 12CH I²C BUS D-A CONVERTER WITH BUFFER AMPLIFIERS

I²C- BUS FORMAT



DIGITAL DATA FORMAT

•SLAVE ADDRESS

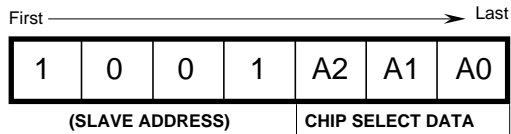

•SUB ADDRESS

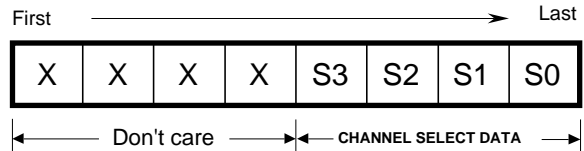

•DAC DATA

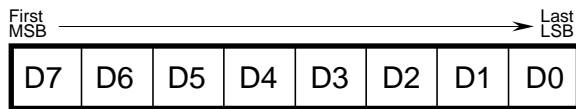

(1)CHIP SELECT DATA

MSB			LSB		
A2	A1	A0	CS2	CS1	CS0
0	0	0	0	0	0
0	0	1	0	0	1
0	1	0	0	1	0
⋮	⋮	⋮	⋮	⋮	⋮
1	1	1	1	1	1

Lower 3bits(A0,A1,A2) are a programmable address. This IC is accessed only when the lower 3 bits data of slave address coincide with the data of CS0 to CS2.(refer to the upper table)

(2)CHANNEL SELECT DATA

MSB				LSB
S3	S2	S1	S0	Channel selection
0	0	0	0	Don't care.
0	0	0	1	ch1 selection
0	0	1	0	ch2 selection
⋮	⋮	⋮	⋮	⋮
1	0	1	1	ch11 selection
1	1	0	0	ch12 selection
1	1	0	1	Don't care.
⋮	⋮	⋮	⋮	⋮
1	1	1	1	Don't care.

(3)DAC DATA

First MSB → Last LSB

D7	D6	D5	D4	D3	D2	D1	D0	DAC output
0	0	0	0	0	0	0	0	$(V_{refU}-V_{refL})/256 \times 1 \times 2.4 + V_{refL}$
0	0	0	0	0	0	0	1	$(V_{refU}-V_{refL})/256 \times 2 \times 2.4 + V_{refL}$
0	0	0	0	0	0	1	0	$(V_{refU}-V_{refL})/256 \times 3 \times 2.4 + V_{refL}$
0	0	0	0	0	0	1	1	$(V_{refU}-V_{refL})/256 \times 4 \times 2.4 + V_{refL}$
⋮	⋮	⋮	⋮	⋮	⋮	⋮	⋮	⋮
1	1	1	1	1	1	1	0	$(V_{refU}-V_{refL})/256 \times 255 \times 2.4 + V_{refL}$
1	1	1	1	1	1	1	1	$(V_{refU}-V_{refL}) \times 2.4 + V_{refL}$

M62398P,FP

8BIT 12CH I²C BUS D-A CONVERTER WITH BUFFER AMPLIFIERS

TIMING CHART (MODEL)

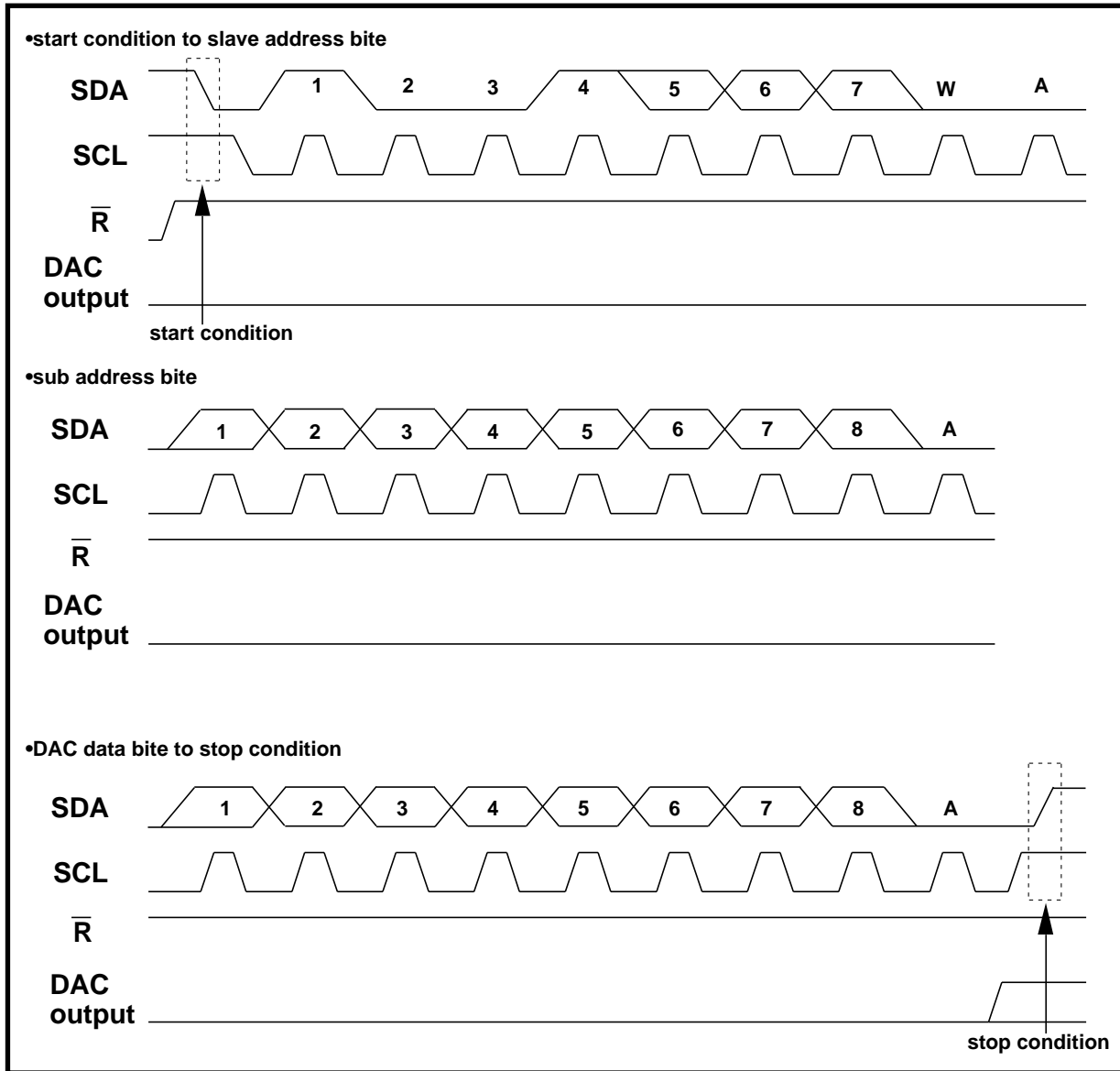

- Start condition With SCL at HIGH,SDA line goes from HIGH to LOW
- Stop condition With SCL at HIGH,SDA line goes from LOW to HIGH
(*Under normal circumstances,SDA is changed when SCL is LOW)
- Acknowledge bit The receiving IC has to pull down SDA line whenever receive slave data.
(The transmitting IC releases the SDA line just then transmit 8bit data.)

M62398P,FP

8BIT 12CH I²C BUS D-A CONVERTER WITH BUFFER AMPLIFIERS

PRECAUTION FOR USE

M62398 have 5 terminals (VDD,VCC,VrefU1,VrefU2,VrefL) for input constant voltage at use.

IF ripple or spike is input these terminals,accuracy of D-A conversion is down. So,when use this device,please connect capacitor among each terminal to GND for stable D-A conversion.

This IC's output amplifier has an advantage to capacitive load.So it's no problem at device action when connect capacitor (0.1μF MAX) among output to GND for every noise eliminate.

<Standard application circuit>

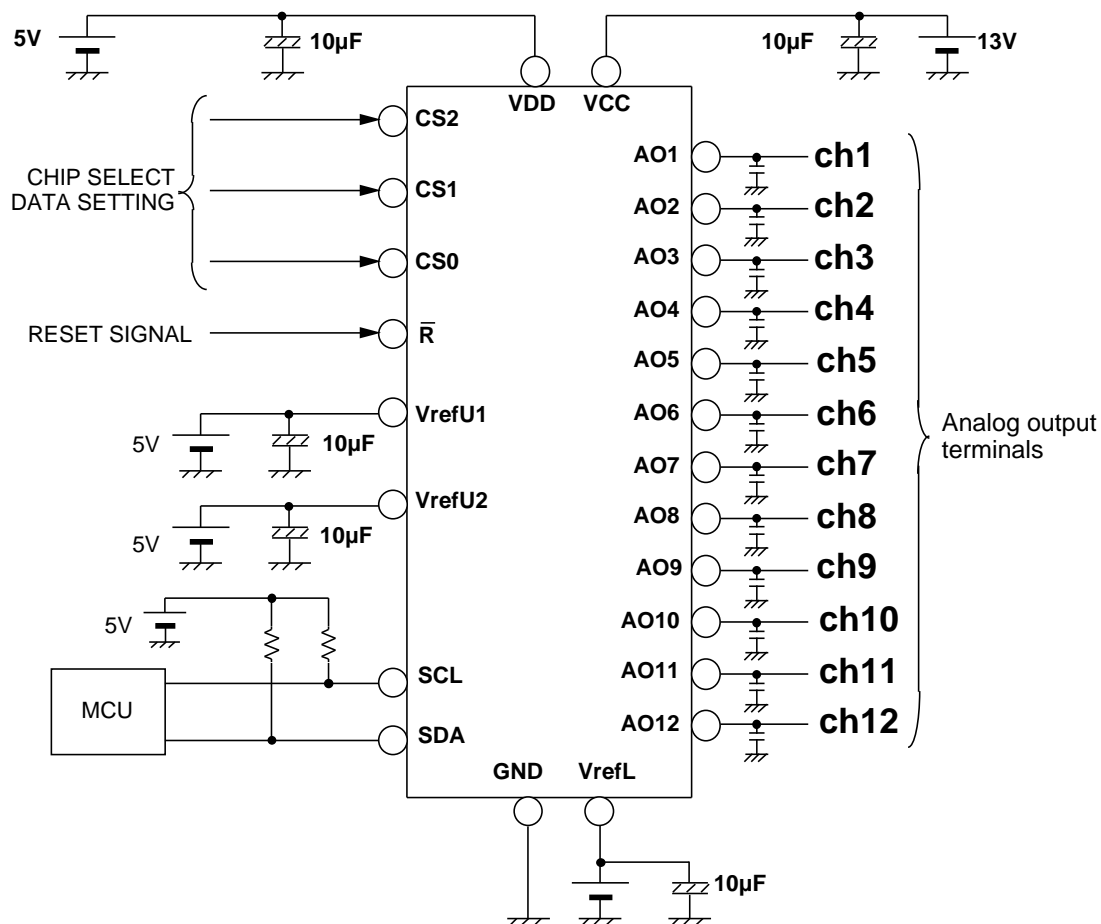

*Purchase of MITSUBISHI ELECTRIC CORPORATION'S I2C components conveys a license under the Philips I2C Patent Rights to use these components an I2C system,provided that the system conforms to I2C Standard Specification as defined by Philips.

⚠ Mitsubishi Electric Corporation puts the maximum effort into making semiconductor products better and more reliable, but there is always the possibility that trouble may occur with them. Trouble with semiconductors may lead to personal injury,fire or property damage.Remember to give due consideration to safety when making your circuit design,in order to prevent fires from spreading,redundancy,malfunction or other mishap.