

AN8014S

Step-down, step-up, or inverting DC-DC converter control IC

Overview

The AN8014S is a single-channel PWM DC-DC converter control IC.

This IC can provide any one output type from among step-down, step-up and inverting output.

Allowing n-channel power MOSFET direct driving, the AN8014S is ideal for high-efficiency power supplies.

Features

- Wide operating supply voltage range (3.6 V to 34 V)
(The voltage is limited within a range between 3.6 V and 17 V if it is connected to a step-down voltage circuit.)
- Totem pole output circuit: output peak current (± 1 A)
- On-chip pulse-by-pulse overcurrent detection and protection circuit

Threshold voltage $V_{CC} - 0.095$ V typical

- On-chip bootstrap circuit (allowing n-channel MOSFET direct driving.)
- On-chip under-voltage lock-out circuit (U.V.L.O.)
- On-chip on/off function (active-high control input, standby current of maximum 5 μ A)
- On-chip timer latch short-circuit protection circuit
- Maximum oscillator frequency (500 kHz)

Applications

- DC-DC switching power supply

Block Diagram

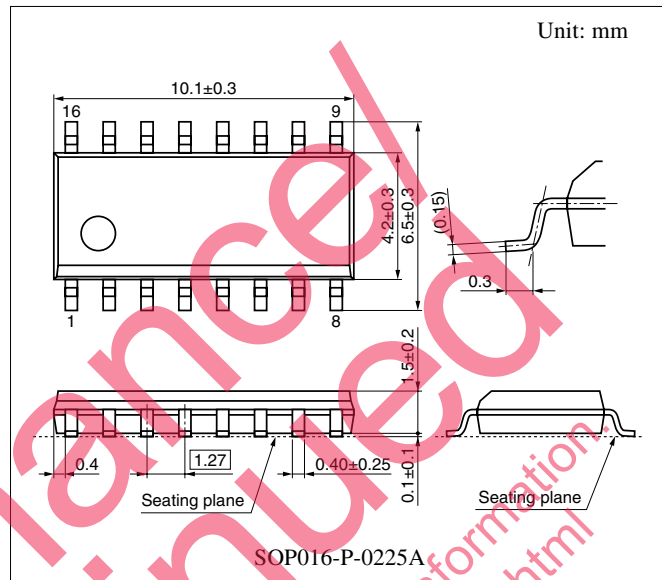
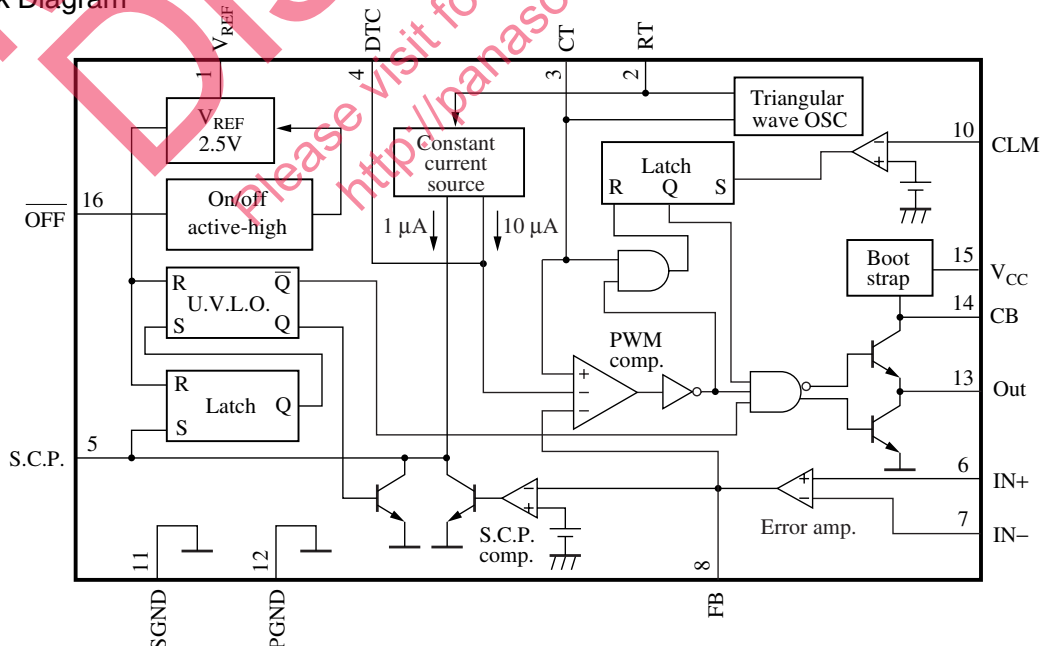

Note) The package of this product will be changed to lead-free type (SOP016-P-0225E). See the new package dimensions section later of this datasheet.

■ Pin Descriptions

Pin No.	Description	Pin No.	Description
1	Internal reference output	9	Not connected
2	Oscillator timing resistor connection	10	Overcurrent protection input
3	Oscillator timing capacitor connection	11	Signal ground
4	Dead-time control	12	Output stage ground
5	Capacitance connection for short-circuit protection delay	13	Totem pole type output
		14	Bootstrap output
6	Error amplifier noninverting input	15	Supply voltage
7	Error amplifier inverting input	16	On/off control
8	Error amplifier output		

■ Absolute Maximum Ratings

Parameter	Symbol	Rating	Unit
Supply voltage	V_{CC}	35	V
Supply current	I_{CC}	—	mA
Power dissipation *2	P_D	143	mW
Operating ambient temperature *1	T_{opr}	-30 to +85	°C
Storage temperature *1	T_{stg}	-40 to +125	°C
On/off pin allowable application voltage	$V_{ON/OFF}$	V_{CC}	V
Error amplifier allowable input voltage	V_I	-0.3 to V_{REF}	V
DTC pin allowable application voltage	V_{DTC}	-0.3 to V_{REF}	V
Out pin allowable application voltage	V_{OUT}	35	V
Out pin constant output current	I_O	±100	mA
Out pin peak output current	$I_{O(Peak)}$	±1 000	mA
CB pin allowable application voltage	V_{CB}	35	V
CB pin constant output current	I_{CB}	-100, 150	mA
CB pin peak output current	I_{CBP}	-500, 1 000	mA
CLM pin allowable application voltage	V_{CLM}	V_{CC}	V

Note) 1. *1: Except for the operating ambient temperature and storage temperature, all ratings are for $T_a = 25^\circ\text{C}$.

*2: At $T_a = 85^\circ\text{C}$

2. Do not apply external currents or voltages to any pins not specifically mentioned.

For circuit currents, '+' denotes current flowing into the IC, and '-' denotes current flowing out of the IC.

■ Recommended Operating Range

Parameter	Symbol	Range		Unit
Supply voltage	V_{CC}	Step-up circuit system	3.6 to 34	V
		Step-down circuit system	3.6 to 17	

■ Electrical Characteristics at $V_{CC} = 12\text{ V}$, $T_a = 25^\circ\text{C}$

Parameter	Symbol	Conditions	Min	Typ	Max	Unit
Reference voltage block						
Output voltage	V_{REF}	$I_{REF} = -1\text{ mA}$	2.522	2.6	2.678	V
Line regulation with input fluctuation	Line	$V_{CC} = 3.6\text{ V to }34\text{ V}$	—	16	25	mV
Load regulation	Load	$I_{REF} = -0.1\text{ mA to }-1\text{ mA}$	—	1	10	mV
U.V.L.O. block						
Circuit operation start voltage	V_{UON}	—	2.8	3.1	3.4	V
Hysteresis width	V_{HYS}	—	60	140	180	mV
Error amplifier block						
Input offset voltage	V_{IO}	—	-6	—	6	mV
Input bias current	I_B	—	-500	-25	—	nA
Common-mode input voltage range	V_{ICR}	—	-0.1	—	0.8	V
High-level output voltage	V_{EH}	—	V_{REF} -0.3	V_{REF} -0.1	—	V
Low-level output voltage	V_{EL}	—	—	0.1	0.3	V
Dead-time control circuit block						
Input current	I_{DTC}	—	-15.8	-13.2	-10.6	μA
Low-level input threshold voltage	V_{DT-L}	Duty 0%	—	0.45	0.65	V
High-level input threshold voltage	V_{DT-H}	Duty 100%	1.2	1.4	—	V
Output block						
Oscillator frequency	f_{OUT}	$C_T = 120\text{ pF}$, $R_T = 15\text{ k}\Omega$	196	218	240	kHz
Output duty	Du	$R_{DTC} = 75\text{ k}\Omega$	47	52	57	%
Low-level output voltage	V_{OL}	$I_O = 70\text{ mA}$	—	1.0	1.3	V
High-level output voltage	V_{OH}	$I_O = -70\text{ mA}$	V_{CB} -2.0	V_{CB} -1.0	—	V
Bootstrap circuit block						
Input standby voltage	V_{INCB}	$I_{CB} = -70\text{ mA}$	V_{CC} -1.2	V_{CC} -1.0	V_{CC} -0.8	V
Short-circuit protection circuit block						
Input threshold voltage	V_{THPC}	—	0.70	0.75	0.80	V
Input standby voltage	V_{STBY}	—	—	30	120	mV
Input latch voltage	V_{IN}	—	—	30	120	mV
Charge current	I_{CHG}	—	-2.76	-2.30	-1.84	μA
On/off control block						
Threshold voltage	V_{TH}	—	0.8	—	2.0	V
Overcurrent protection block						
Threshold voltage	V_{CLM}	—	V_{CC} -0.115	V_{CC} -0.095	V_{CC} -0.075	V

■ Electrical Characteristics at $V_{CC} = 12\text{ V}$, $T_a = 25^\circ\text{C}$ (continued)

Parameter	Symbol	Conditions	Min	Typ	Max	Unit
Whole device						
Total consumption current	I_{CC}	—	—	5.0	7.0	mA
Standby current	$I_{CC(SB)}$	—	—	—	5	μA

• Design reference data

Note) The characteristics listed below are theoretical values based on the IC design and are not guaranteed.

Parameter	Symbol	Conditions	Limit	Unit
Reference voltage block				
Output voltage temperature characteristics 1	V_{TC1}	$T_a = -30^\circ\text{C}$ to $+25^\circ\text{C}$	± 1	%
Output voltage temperature characteristics 2	V_{TC2}	$T_a = 25^\circ\text{C}$ to 85°C	± 1	%
Output short-circuit current	I_{OS}	—	-40	mA
Error amplifier block				
Output sink current	I_{SINK}	$V_{FB} = 0.9\text{ V}$	8	mA
Output source current	I_{SOURCE}	$V_{FB} = 0.9\text{ V}$	-110	μA
Open-loop gain	A_G	—	70	dB
Output block				
Frequency supply voltage characteristics	f_{dV}	$f_{OUT} = 200\text{ kHz}$, $V_{CC} = 3.6\text{ V}$ to 34 V	± 3	%
Frequency temperature characteristics 1	f_{dT1}	$f_{OUT} = 200\text{ kHz}$, $T_a = -30^\circ\text{C}$ to $+25^\circ\text{C}$	± 9	%
Frequency temperature characteristics 2	f_{dT2}	$f_{OUT} = 200\text{ kHz}$, $T_a = 25^\circ\text{C}$ to 85°C	± 9	%
Oscillator block				
RT pin voltage	V_{RT}	—	0.4	V
Short-circuit protection circuit block				
Comparator threshold voltage	V_{THL}	—	1.87	V
Overcurrent protection circuit block				
Delay time	t_{DLY}	—	200	ns

Terminal Equivalent Circuits

Pin No.	I / O	Equivalent circuit	Description
1	O		<p>V_{REF}: Outputs the reference voltage 2.6 V (allowance: 3%) Incorporating short-circuit protection against ground.</p>
2	—		<p>RT: Connection for the timing resistor which decides the oscillator frequency. Use a resistor in the range 5.1 kΩ to 30 kΩ. The pin voltage is approx. 0.4 V.</p>
3	—		<p>CT: Connection for the timing capacitor which decides the oscillator frequency. Use a capacitor in the range 100 pF to 10000 pF. For the oscillator frequency setting, refer to the "Application Notes, [1] Function descriptions" section. Use an oscillator frequency in the range 5 kHz to 500 kHz.</p>
4	—		<p>DTC: Connection for a resistor and a capacitor that set the dead-time and soft start period of PWM output. Input current I_{DTC} is decided by the timing resistor R_T which controls sample to sample variations and temperature variations. It is approx. $-13.2 \mu A$ when $R_T = 15 k\Omega$.</p> $I_{DTC} = \frac{V_{RT}}{R_T} \times \frac{1}{2} [A]$

■ Terminal Equivalent Circuits (continued)

Pin No.	I / O	Equivalent circuit	Description
5	—		<p>S.C.P.:</p> <p>Connection for the capacitor that sets the soft start period and the timer latch short-circuit protection circuit time constant. Use a capacitor with a value of 1 000 pF or higher.</p> <p>The charge current I_{CHG} is decided by the timing resistor R_T which controls sample to sample variations and temperature variations.</p> <p>It is approx. $-2.3 \mu A$ when $R_T = 15 k\Omega$.</p> $I_{CHG} = \frac{V_{RT}}{R_T} \times \frac{1}{11} [A]$
6	I		<p>IN+:</p> <p>Noninverting input to the error amplifier. Use the common-mode input in the range $-0.1 V$ to $+0.8 V$.</p>
7	I		<p>IN-:</p> <p>Inverting input to the error amplifier. Use the common-mode input in the range $-0.1 V$ to $+0.8 V$.</p>
8	O		<p>FB:</p> <p>Output from the error amplifier. The source current is approx. $-110 \mu A$ and sink current is approx. $8 mA$. Correct the frequency characteristics of the gain and the phase by connecting a resistor and a capacitor between this pin and IN- pin.</p>
9	—		N.C.: Not connected.
10	I		<p>CLM:</p> <p>Detects the overcurrent state in switching transistor. Insert a resistor with a low resistance between this pin and V_{CC} to detect overcurrent states. When this pin falls to a level 95 mV or more lower than V_{CC}, the PWM output is turned off for that period thus narrowing the width of the on-period. (This implements a pulse-by-pulse overcurrent protection technique.)</p>

■ Terminal Equivalent Circuits (continued)

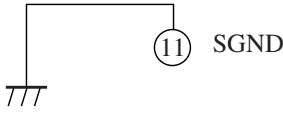
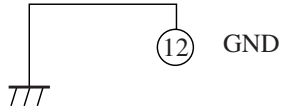
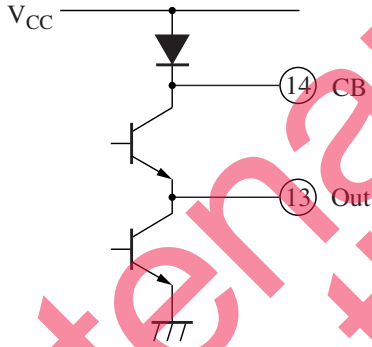
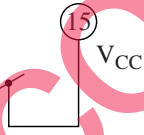
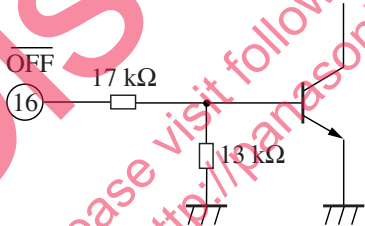
Pin No.	I / O	Equivalent circuit	Description
11	—		SGND: Signal ground.
12	—		GND: Output stage ground.
13	O		<p>Out: Totem pole output.</p> <p>A constant output current of ± 100 mA or a peak output current of ± 1 A can be obtained.</p>
14	O		<p>CB: Bootstrap output.</p> <p>Connect a bootstrap capacitor between this pin and the n-channel MOSFET source-side pin of the switching element when using a step-down voltage circuit.</p> <p>Short-circuit this pin and the V_{CC} pin when using a step-up voltage circuit.</p>
15	I		V_{CC} : Power supply.
16	I		<p>$\overline{\text{OFF}}$: Controls the on/off state.</p> <p>When the input is high: normal operation ($V_{\overline{\text{OFF}}} > 2.0$ V)</p> <p>When the input is low: standby mode ($V_{\overline{\text{OFF}}} < 0.8$ V)</p> <p>In standby mode, the total current consumption is held to under 10 μA.</p>

■ Application Notes

[1] Function descriptions

1. Reference voltage block

This block is composed of the band gap circuit and outputs the temperature compensated reference voltage (2.6 V) to the V_{REF} pin (pin 1). The reference voltage is stabilized when the supply voltage is 3.6 V or more and used as the operating power supply in IC. It is possible to take out a load current of up to -1 mA.

■ Application Notes (continued)

[1] Function descriptions (continued)

2. The triangular wave generator block (OSC)

The triangular wave which swings from approximately 1.32 V (upper limit value, V_{OSCH}) to approximately 0.44 V (lower limit value, V_{OSCL}) will be generated by connecting a timing capacitor C_T and a resistor R_T to the C_T pin (pin 3) and R_T pin (pin 2) respectively. Oscillator frequency can be freely decided by the value of C_T and R_T connected externally. The oscillator frequency f_{OSC} is obtained by the following formula;

$$f_{OSC} = \frac{1}{t_1 + t_2} = \frac{I_O}{2 \times C_T \times (V_{CTH} - V_{CTL})}$$

$$I_O = 1.7 \times \frac{V_{RT}}{R_T} = 1.7 \times \frac{0.4}{R_T}$$

Because $V_{CTH} - V_{CTL} = 0.88$ V

$$f_{OSC} \approx \frac{1}{2.59 \times C_T \times R_T} \text{ [Hz]}$$

Example) An f_{OSC} of approximately 215 kHz will be obtained if C_T is 120 pF and R_T is 15 k Ω .

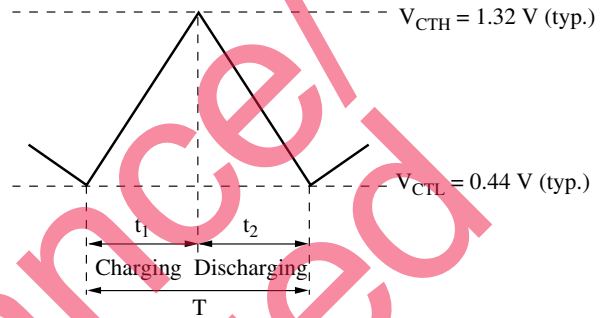

Figure 1. Triangular oscillation waveform

It is possible to use the circuit in the recommended operating range of 5 kHz to 500 kHz of the oscillator frequency. As the AN8014S is used at increasingly higher frequencies, the amount of overshoot and undershoot due to the operation delay in the triangular wave oscillator comparator increases, and discrepancies between the values calculated as described previously and the actual values may occur.

The output source currents of the AN8014S's S.C.P. and DTC pins are determined by the timing resistor R_T which is externally connected to the R_T pin. Therefore, note that this IC can not be used as an IC for slave when the several ICs are operated in parallel synchronous mode.

3. Error amplifier block

Detecting and amplifying DC-DC converter output voltage, the error amplifier with pnp transistor input inputs the signal to the PWM comparator.

Figure 2 shows the way to connect the error amplifier.

The common-mode input voltage range is -0.1 V to $+0.8$ V, and a voltage obtained by dividing the reference voltage with built-in resistors is applied to the non-inverting input. Connecting the feedback resistor and the capacitor between the error amplifier output pin (pin 8) and the inverting input pin (pin 7) allows the arbitrary gain setting and the phase compensation.

Startup overshooting caused by feedback delays will be suppressed by setting the output source current and output sink current to as high as 110 μ A and 8 mA respectively.

The input voltage V_{IN+} and V_{IN-} to the error amplifier are obtained from the following formulas.

$$V_{IN+} = V_{REF} \times \frac{R_4}{R_3 + R_4} \quad V_{IN-} = V_{OUT} \times \frac{R_2}{R_1 + R_2}$$

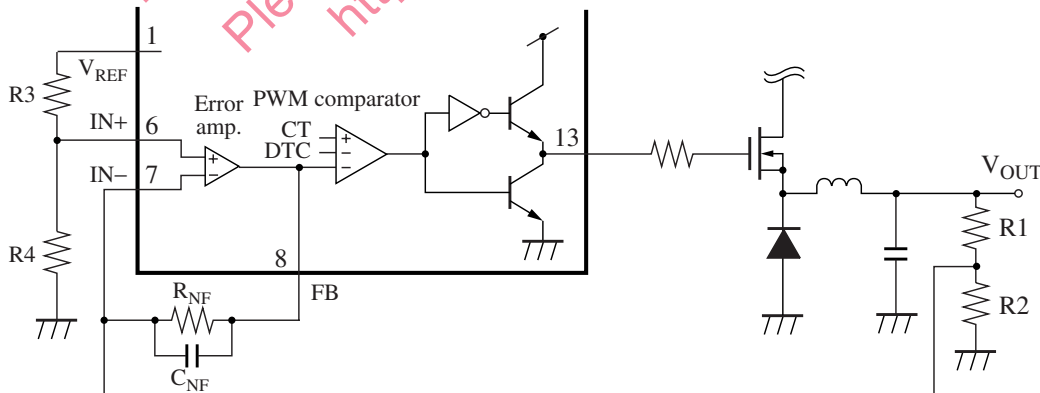

Figure 2. Connection method of error amplifier

■ Application Notes (continued)

[1] Function descriptions (continued)

4. Timer latch short-circuit protection circuit

This circuit protects external main switching devices, flywheel diodes, choke coils and so forth from breakdown or deterioration when overload or short-circuit of power supply lasts a certain time.

Figure 3 shows the short-circuit protection circuit. The timer latch short-circuit protection circuit detects the output level of the error amplifier.

If the output voltage of the DC-DC converter is stable, the output of the error amplifier from the FB pin is stable and the short-circuit protection comparator is well balanced.

In that case, the transistor Q1 is conductive and the S.C.P. pin voltage is approximately 30 mV constantly.

If the load condition changes radically and output signal voltage of the error amplifier (FB) is 1.87 V or higher, the short-circuit protection comparator outputs low-level voltage. Then, by cutting off the transistor Q1, the external capacitor C_S of S.C.P. pin (pin 5) starts charging with the current I_{CHG} which is obtained from the following formulas.

$$V_{PE} = V_{STBY} + I_{CHG} \times \frac{t_{PE}}{C_S} \quad [V]$$

$$0.75 \text{ V} = 0.03 \text{ V} + I_{CHG} \times \frac{t_{PE}}{C_S}$$

$$C_S = I_{CHG} \times \frac{t_{PE}}{0.72} \quad [F]$$

I_{CHG} is constant current which is determined by the timing resistor R_T .

If R_T is 15 k Ω , I_{CHG} will be approximately 2.3 μ A.

$$I_{CHG} = \frac{V_{RT}}{R_T} \times \frac{1}{11} \quad [A]$$

When the external capacitor C_S is charged up to approximately 0.75 V, the latch circuit will be turned on. Then the totem-pole output pin will be set to low level and the dead-time will be set to 100%.

When the latch circuit is turned on, the S.C.P. pin will discharge electricity till the voltage on the S.C.P. pin reduces to approximately 30 mV. The latch circuit cannot be, however, reset until power supply to the AN8014S is turned off.

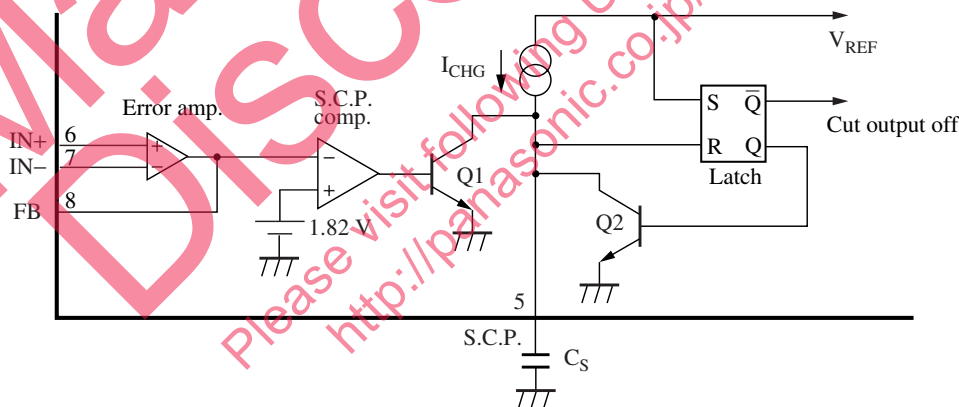

Figure 3. Short-circuit protection circuit

5. Low input voltage malfunction prevention circuit (U.V.L.O.)

This circuit protects system from breakdown or deterioration caused by malfunction in control circuit when supply voltage is dropped during transient time at power on or off.

The low input voltage malfunction prevention circuit detects internal reference voltage which changes in accordance with the supply voltage level. When the supply voltage is turned on, it sets the dead-time of Out pin (pin 13) to 100% and keeps the DTC pin (pin 4) and S.C.P. pin (pin 5) low level until the supply voltage reaches 3.1 V. When the supply voltage falls, it will operate even below 2.96 V because of its hysteresis width of 140 mV.

■ Application Notes (continued)

[1] Function descriptions (continued)

6. Remote circuit

It is possible to switch on or off the IC control by using an external control signal. When the $\overline{\text{OFF}}$ pin (pin 16) voltage is lowered to below approximately 0.8 V, the internal reference voltage goes down thereby stopping the IC control and reducing the circuit current to 5 μA or less. When the $\overline{\text{OFF}}$ pin voltage is increased to approximately 2.0 V or more, the internal reference voltage rises thereby starting the control operation.

7. PWM comparator block

The PWM comparator controls the on-period of output pulse in accordance with the input voltage. While the triangular wave voltage on the CT pin (pin 3) is lower than both the error amplifier's output voltage on pin 8 and the voltage on the DTC pin (pin 4), the output on the Out pin (pin 13) will be set to high level. Then the switching element (n-channel MOSFET) will be turned on.

The dead-time is set by adjusting the voltage V_{DTC} on the DTC pin (pin 5) as shown in figure 4.

The DTC pin has constant current output determined by the resistor R_{T} . Therefore V_{DTC} is adjusted by connecting the DTC and GND pins through the external resistor R_{DTC} .

When the oscillator frequency f_{OSC} is 200 kHz, the output duty cycle will be 0% at V_{DTC} of 0.44 V typical and 100% at V_{DTC} of 1.32 V typical.

The levels of overshooting and undershooting of the peak value V_{CTH} and the trough value V_{CTL} of the triangular wave vary with the oscillator frequency.

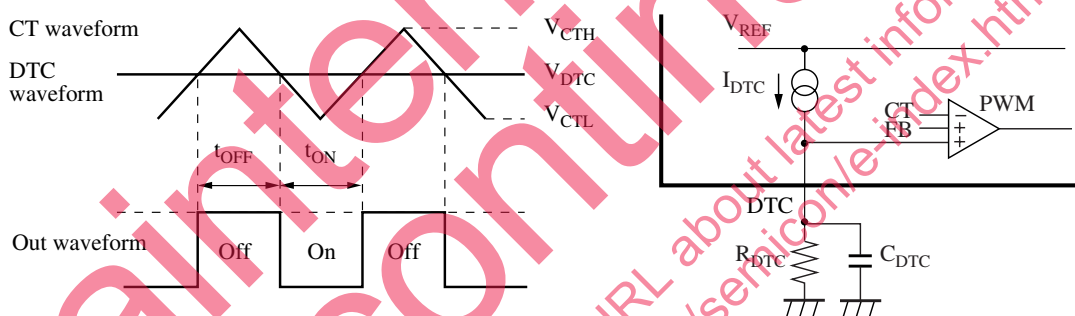

Figure 4. Setting the dead-time

Output duty ratio Du and DTC pin voltage V_{DTC} are expressed by the following formulas;

$$Du = \frac{t_{\text{ON}}}{t_{\text{ON}} - t_{\text{OFF}}} \times 100 [\%] = \frac{V_{\text{DTC}} - V_{\text{CTL}} \times 1.1}{(V_{\text{CTH}} - V_{\text{CTL}}) \times 1.1} \times 100 [\%]$$

$$I_{\text{DTC}} = \frac{V_{\text{RT}}}{R_{\text{T}}} \times \frac{1}{2} [\text{A}]$$

$$V_{\text{DTC}} = I_{\text{DTC}} \times R_{\text{DTC}} = V_{\text{RT}} \times \frac{R_{\text{DTC}}}{R_{\text{T}}} \times \frac{1}{2} [\text{V}]$$

Example) When $f_{\text{OSC}} = 215$ [kHz] ($R_{\text{T}} = 15$ k Ω , $C_{\text{T}} = 120$ pF) and $R_{\text{DTC}} = 75$ [k Ω]

V_{CTH} is approximately 1.32 V, V_{CTL} is approximately 0.44 V, and V_{RT} is approximately 0.4 V. Therefore, the following are obtained.

$$I_{\text{DTC}} \approx 13.3 [\mu\text{A}]$$

$$V_{\text{DTC}} \approx 0.99 [\text{V}]$$

$$Du \approx 52.3 [\%]$$

There may be an operational delay of the PWM comparator and a difference in peak and trough values of the triangular wave oscillation. Discrepancies between the values obtained from the above formulas and the actual values may occur, in which case adjust the values on the mounting substrate.

In starting, if the capacitor C_{DTC} is added in parallel to the external resistor R_{DTC} , and the output pulse width are gradually widened, the AN8014S will be in soft-start operation. Thus the overshoot at the output of DC-DC converters can be prevented.

■ Application Notes (continued)

[1] Function descriptions (continued)

8. Overcurrent protection block

Utilizing that the overcurrent of power output is proportional to the current value which flows in the main switch (power MOSFET), the block regulates the upper limit of the current flowing in the main switch, thus protects the parts such as main switch device, a flywheel diode and a choke coil from the damage caused by the overcurrent.

The current detection are done by monitoring, at CLM pin (pin 10), the voltage drop in resistor which is placed between the main switch device and V_{CC} pin.

When the main switch device (power MOSFET) is switched on and the voltage of CLM pin reaches " $V_{CC} - 95 \text{ mV}$ ", threshold level for overcurrent detection, the output drive transistor is cut off so that no more current flows in the main switch device. This control is repeated at each cycle. When overcurrent is detected once, the transistor remains off during the same cycle, and is switched on in the next cycle.

Such an overcurrent detection method is called "Pulse-by-pulse overcurrent detection."

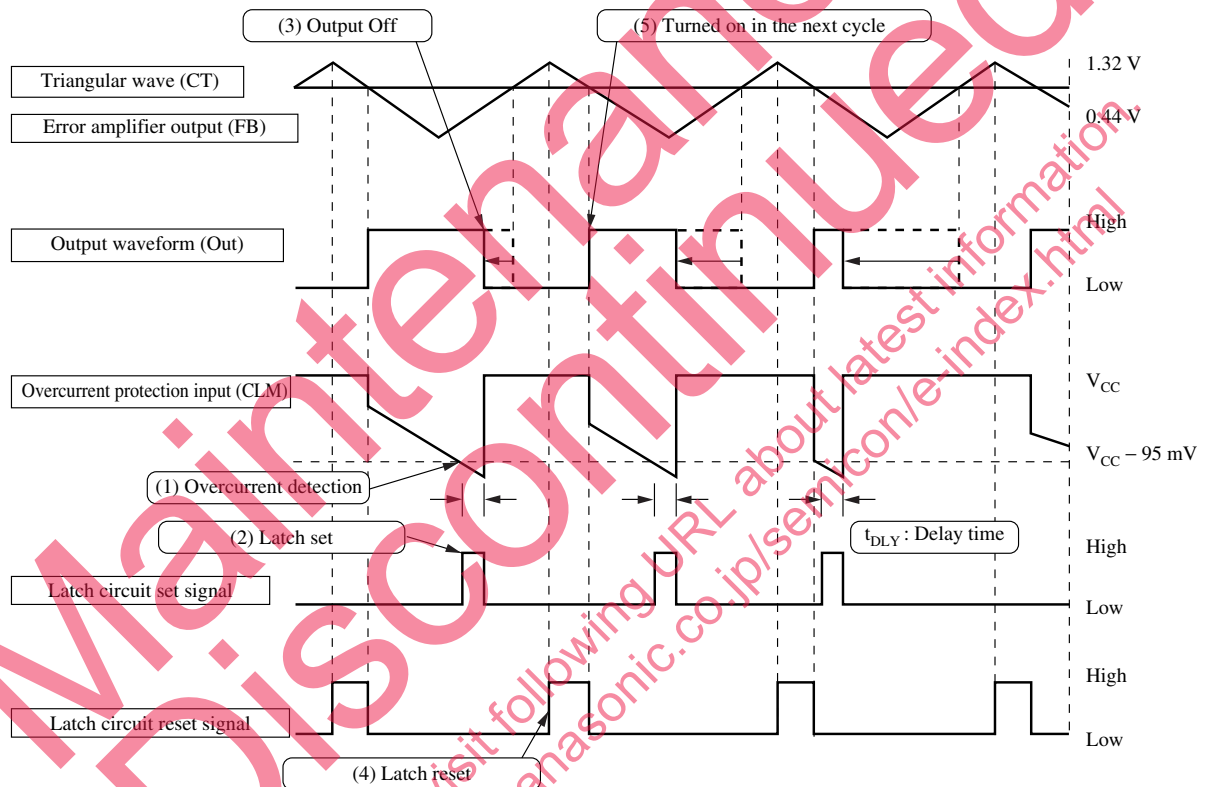

Figure 5. Waveforms of the pulse-by-pulse overcurrent protection operation

R_2 and C_1 shown in figure 6 constitute a low-pass filter to eliminate noise due to parasitic capacitance when the power MOSFET is turned on.

The cut-off frequency of the filter is obtained from the following.

$$f_c = \frac{1}{2\pi C_1 R_2} \text{ [Hz]}$$

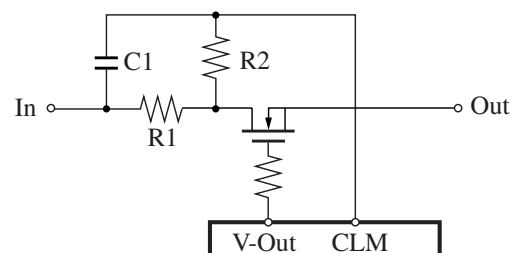

Figure 6. CLM noise filter circuit

■ Application Notes (continued)

[1] Function descriptions (continued)

9. Bootstrap circuit of output block

If the n-channel MOSFET is used as a switching device for DC-DC converter control of step down method, a bootstrap circuit is required.

Bootstrap circuit ensures that the gate-source voltage is gate threshold voltage or higher by going up the high level of the Out pin (pin 13) than V_{CC} voltage when n-channel MOSFET turns on. Figure 7 shows the output of bootstrap circuit including the external circuit. Figure 8 shows the operating waveform of the bootstrap circuit.

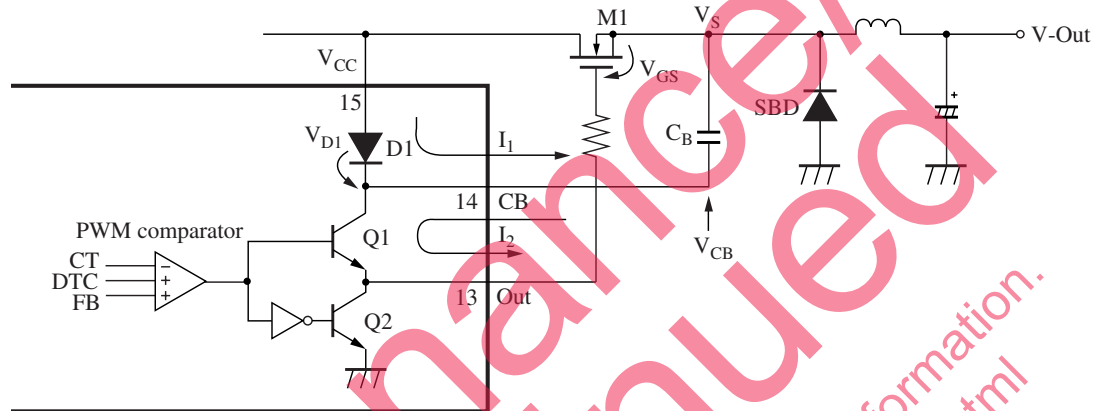

Figure 7. Bootstrap circuit of output block

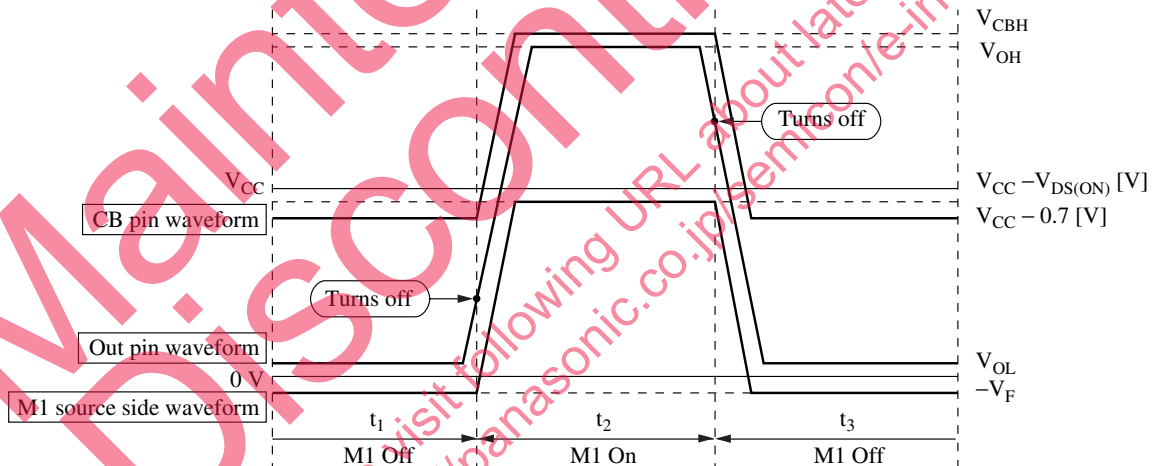

Figure 8. Bootstrap circuit operating waveform

The following describes the operation of the bootstrap circuit.

1) N-channel MOSFET (M1) off time: t_1

While the M1 is turned off, the choke coil is provided with energy from the Schottky barrier diode (SBD) and the source-side voltage V_S of the M1 is fixed to $-V_F$. The bootstrap capacitor C_B is charged from the V_{CC} pin (pin 15) through the AN8014S's internal diode D1.

The voltage V_{CB} on the CB pin (pin 14) is expressed by the following.

$$V_S = -V_F$$

$$V_{CB} = V_{CC} - V_{D1}$$

V_F : Forward voltage of SBD

V_{D1} : Forward voltage of D1

Therefore, the charged voltage of bootstrap capacitor C_B is expressed by the following.

$$V_{CB} - V_S = V_{CC} - V_{D1} + V_F$$

■ Application Notes (continued)

[1] Function descriptions (continued)

9. Bootstrap circuit of output block (continued)

2) N-channel MOSFET (M1) turn-on time: t_2

When the PWM comparator output is inverted, the Out pin (pin 13) output changes into a high level. The Out pin voltage V_O rises toward the CB pin voltage.

$$V_O = V_{CB} - V_{CE(sat)}$$

Then the voltage between the gate and source of the M1 is obtained from the following.

$$V_{GS} = V_O + V_F$$

When the Out pin voltage V_O is the same as or higher than the gate threshold voltage V_{TH} , the M1 turns on. Then the M1 source-side voltage rises up to the voltage expressed by the following.

$$V_S = V_{CC} - V_{DS(ON)}$$

The bootstrap capacitor C_B is connected to the source side and CB pin of the M1. Therefore, the CB pin voltage rises according to the M1 source-side voltage due to capacitor coupling. V_{CB} is expressed by the following formula.

$$\begin{aligned} V_{CB} &= V_S + V_{CC} - V_{D1} + V_F \\ &= 2 \times V_{CC} - V_{D1} + V_{DS(ON)} + V_F \end{aligned}$$

3) N-channel MOSFET (M1) turn-off time: t_3

The Out pin voltage turns off after rising to the saturation voltage of the AN8014S's internal transistor Q1.

The M1 source-side voltage drops to $-V_F$. The CB pin voltage drops to $V_{CC} - V_{D1}$ or below due to capacitive coupling. Then the M1 will be in the state described in the above 1).

[2] Bootstrap circuit usage notes

1. Operating voltage range for step-down circuit

Just like what described previously, if a step-down circuit is in DC-DC converter control, the CB pin (pin 14) voltage will be approximately twice as high as V_{CC} when the n-channel MOSFET as a switching element is turned on. The allowable voltage applied to the CB pin is 35 V. Therefore the operating supply voltage must be within a range between 3.6 V and 17 V.

$$V_{CB} = 2 \times V_{CC} - V_{D1} - V_{DS(ON)} + V_F < 35 \text{ [V]}$$

$$V_{CC} < \frac{35 + V_{D1} + V_{DS(ON)} - V_F}{2} \text{ [V]} < 17 \text{ [V]}$$

2. Value setting of bootstrap capacitor

The bootstrap capacitor raises the CB pin voltage to V_{CC} or higher due to capacitor coupling to the source side of the n-channel MOSFET when the n-channel MOSFET is turned on. At that time bootstrap capacitor is discharged by n-channel MOSFET gate-drive-current. If the capacitance of the bootstrap capacitor is too low, an increase in switching loss will result, which will reduce the efficiency.

Therefore, the capacitance must be large enough in comparison with the gate input capacitance of the n-channel MOSFET. Refer to the following.

$$C_B > C_{iss}$$

Determine the best value by testing on the printed circuit board for mounting.

3. CB pin connection for step-up circuit

If a step-up circuit is in DC-DC converter control, no bootstrap circuit is required because the source side of the n-channel MOSFET is grounded. Therefore, short-circuit the CB pin (pin 14) and the V_{CC} pin (pin 15).

Thus, the operating supply voltage range in the step-up circuit method is between 3.6 V and 34 V.

■ Application Notes (continued)

[3] Timing chart

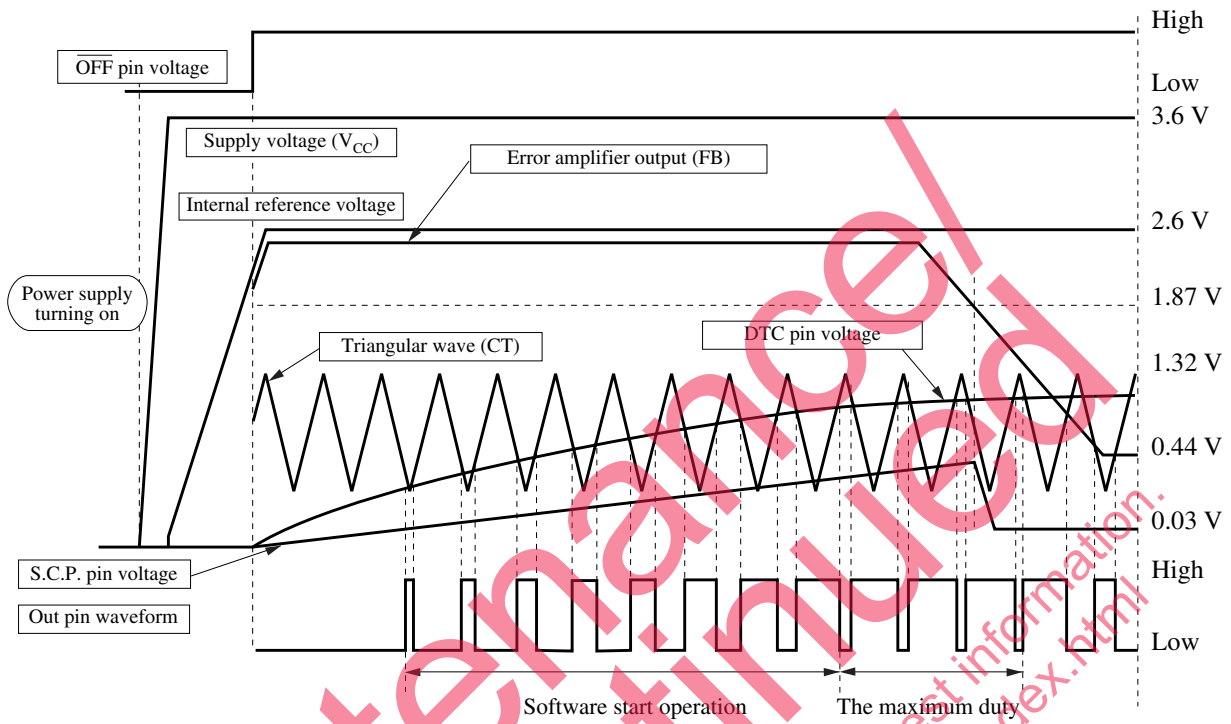

Figure 1. PWM comparator operation waveform

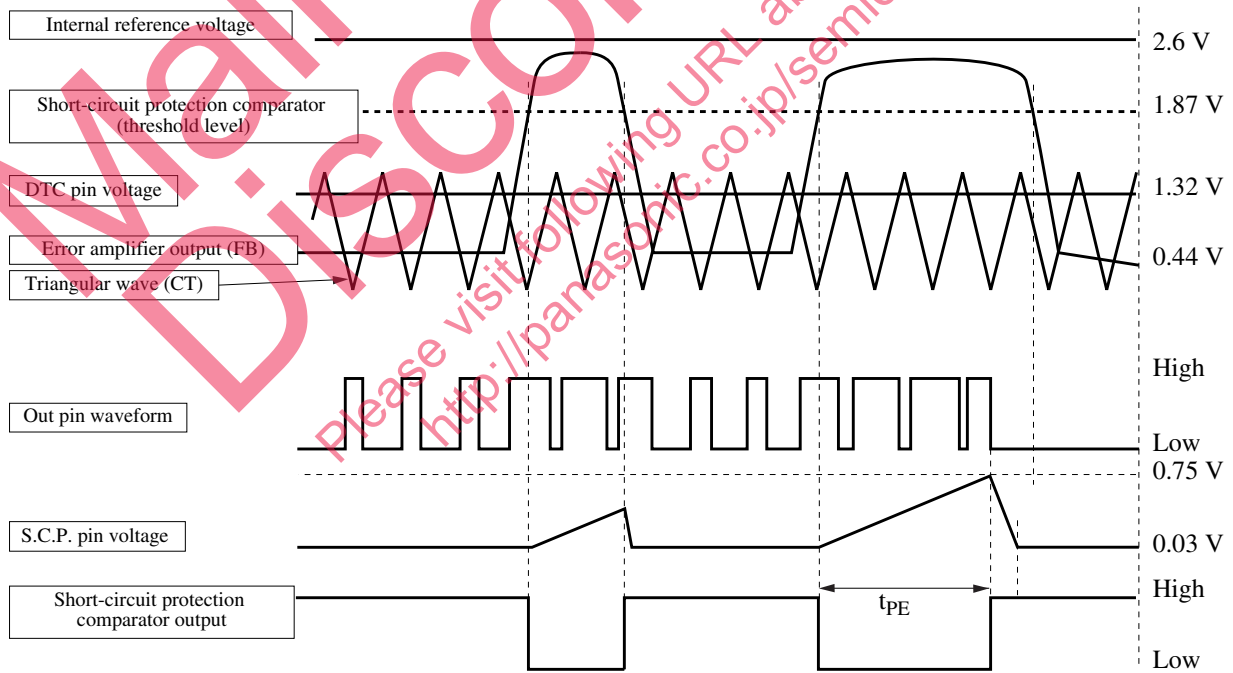

Figure 2. Short-circuit protection operation waveform

■ Application Notes (continued)

[3] Timing chart (continued)

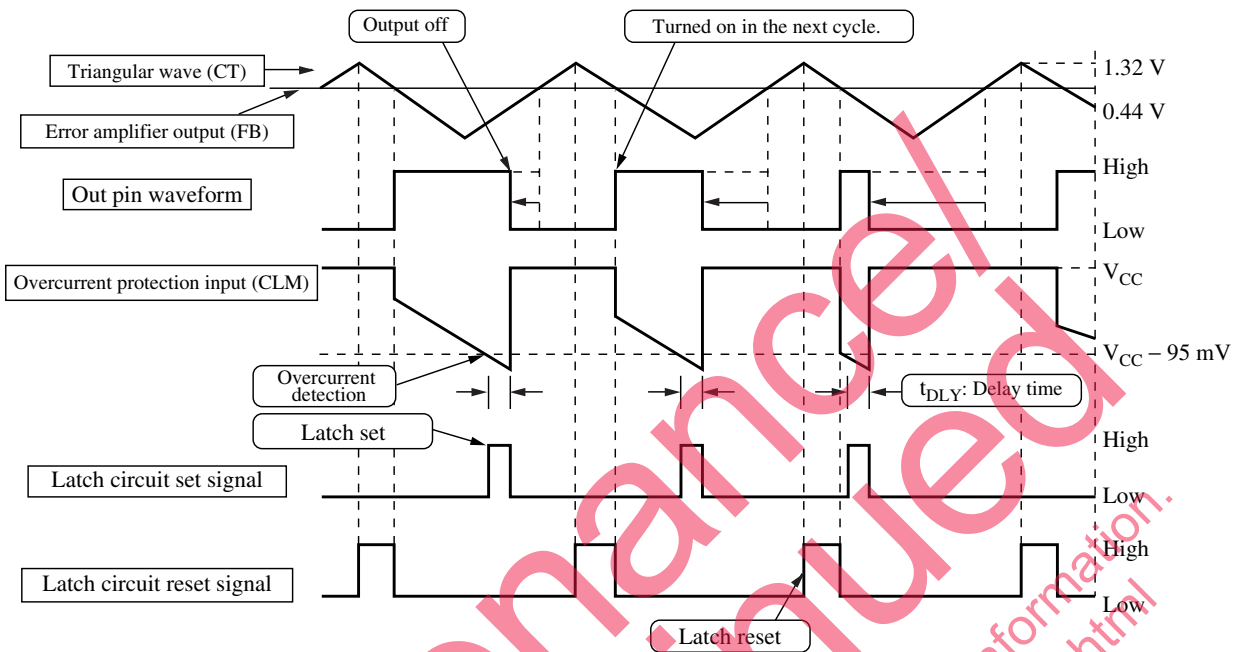
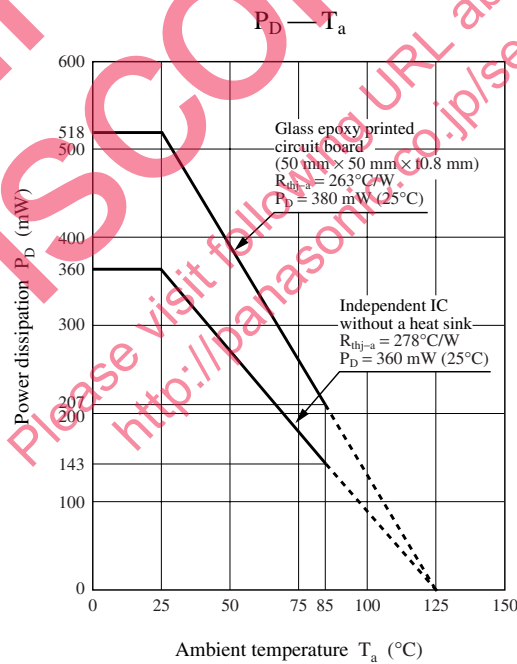

Figure 3. Waveforms of the pulse-by-pulse overcurrent protection operation

[4] $P_D - T_a$ curves of SOP016-P-0225A



■ Application Notes (continued)

[5] Main characteristics

Internal reference voltage temperature characteristics

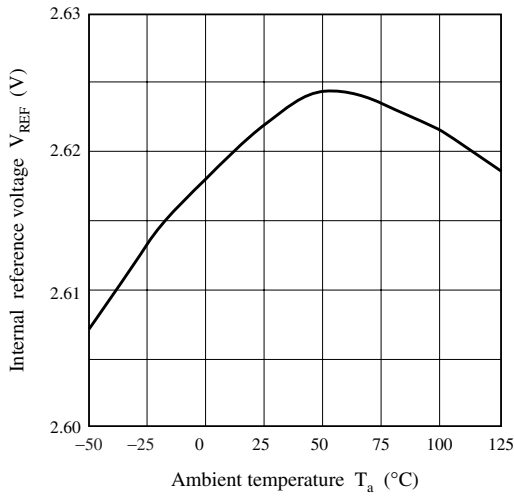

Oscillator frequency temperature characteristics

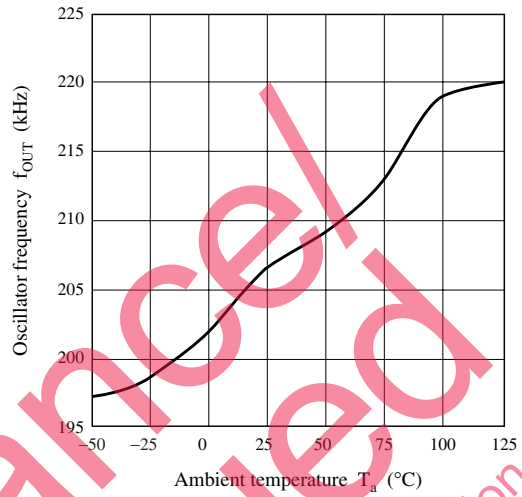

Output duty ratio — DTC pin voltage

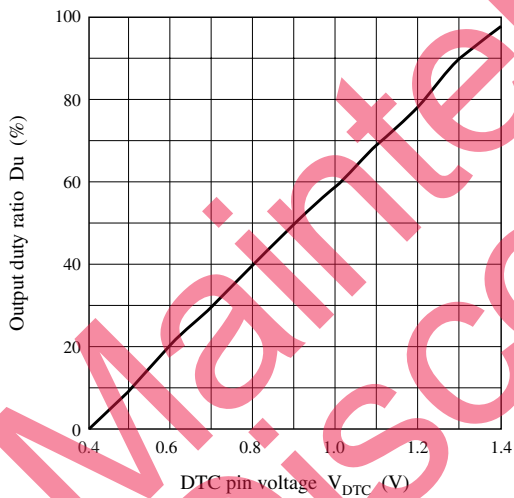

Output duty ratio temperature characteristics

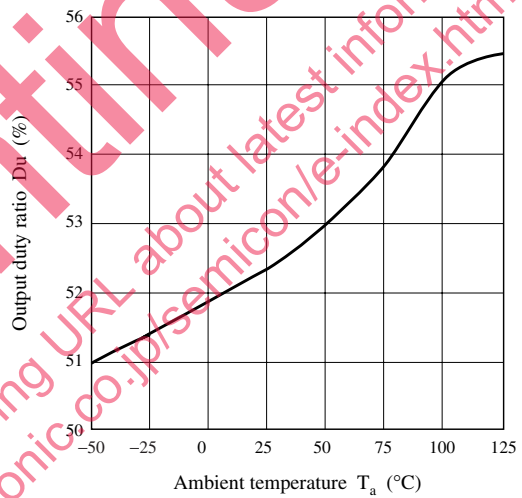

Oscillator frequency — Timing capacitance

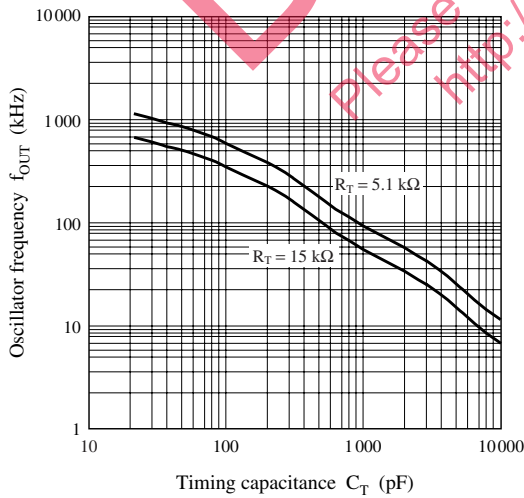

Output peak current — C_{OUT}

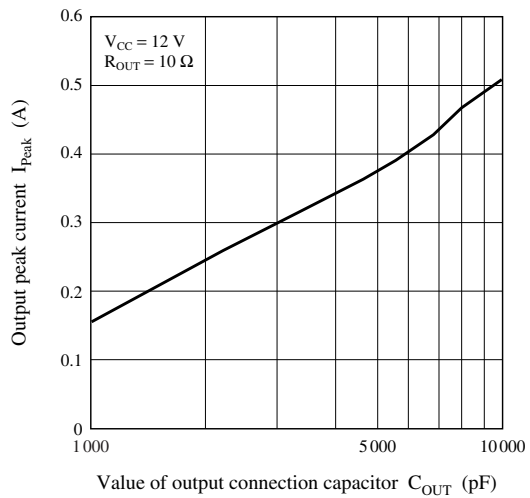

■ Application Circuit Examples

1. DC-DC converter control (Example of step-down circuit)

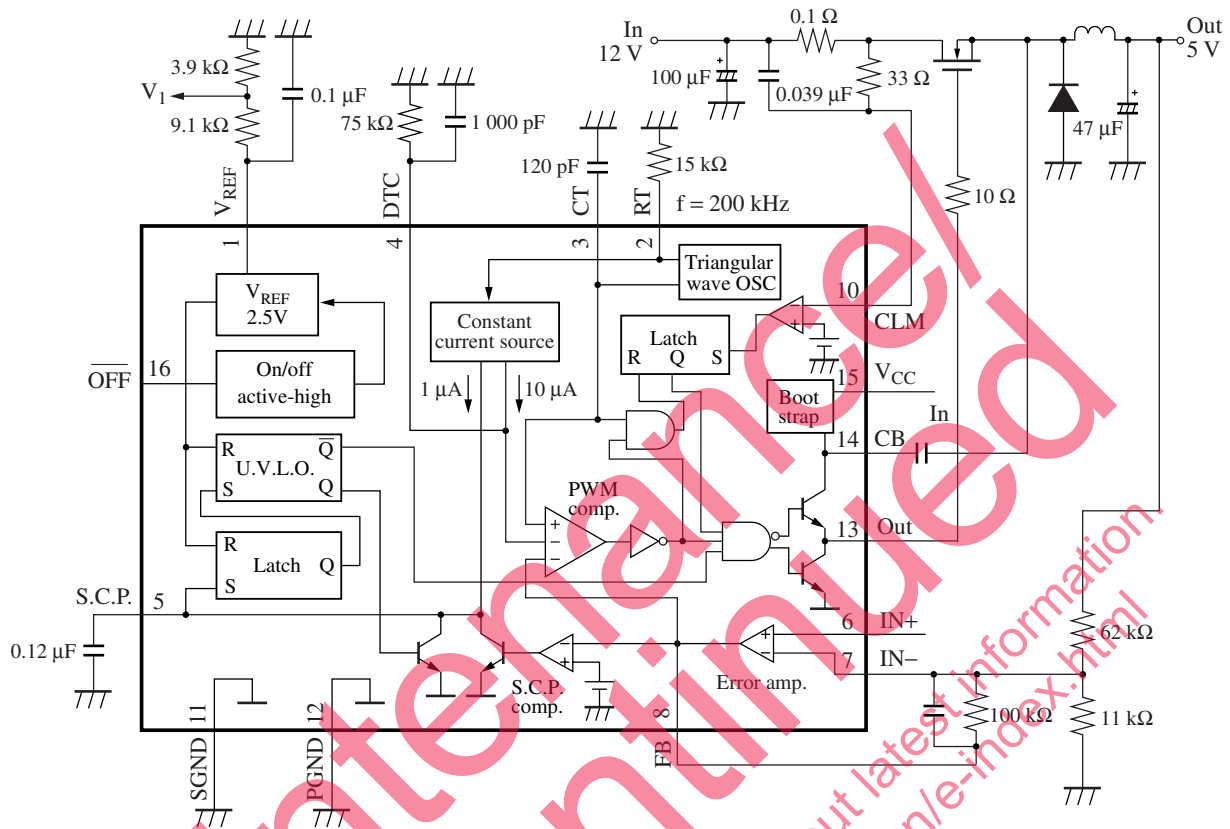

2. DC-DC converter control (Example of step-up circuit)

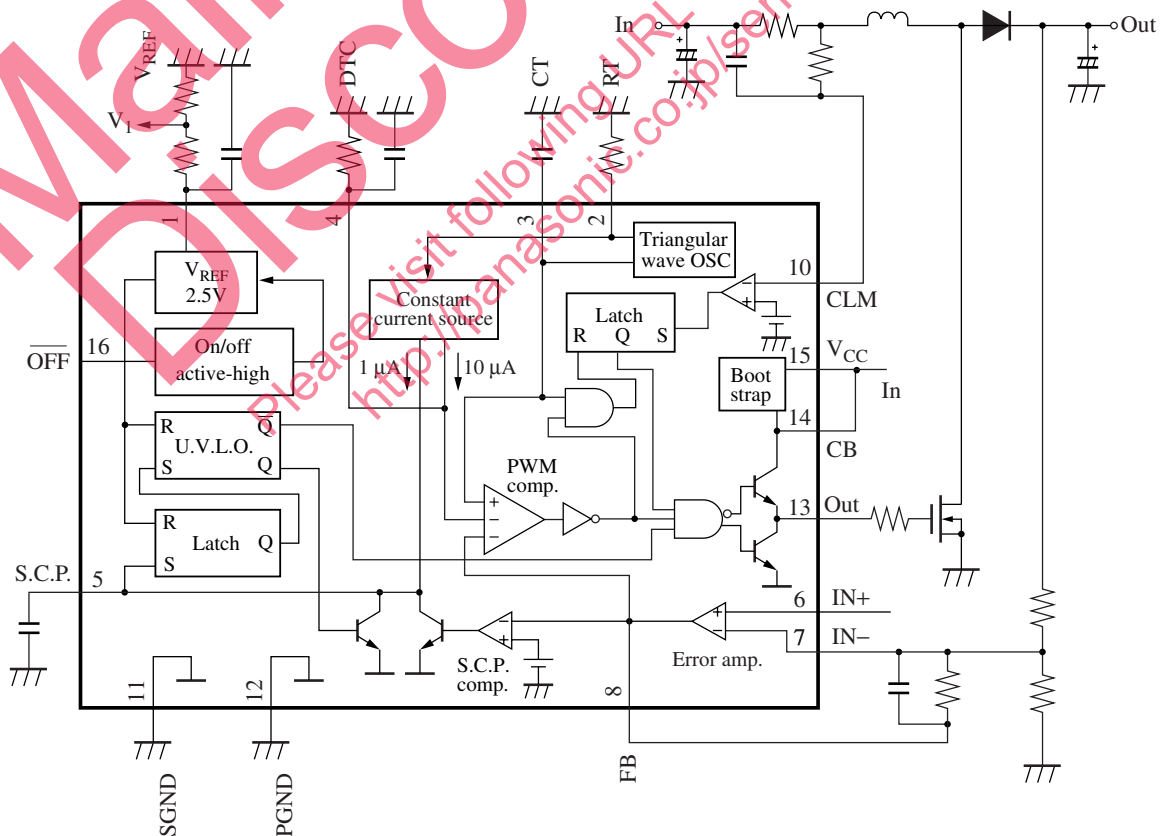

■ Application Circuit Examples (continued)

3. DC-DC converter control (Example of polarity-inverting circuit)

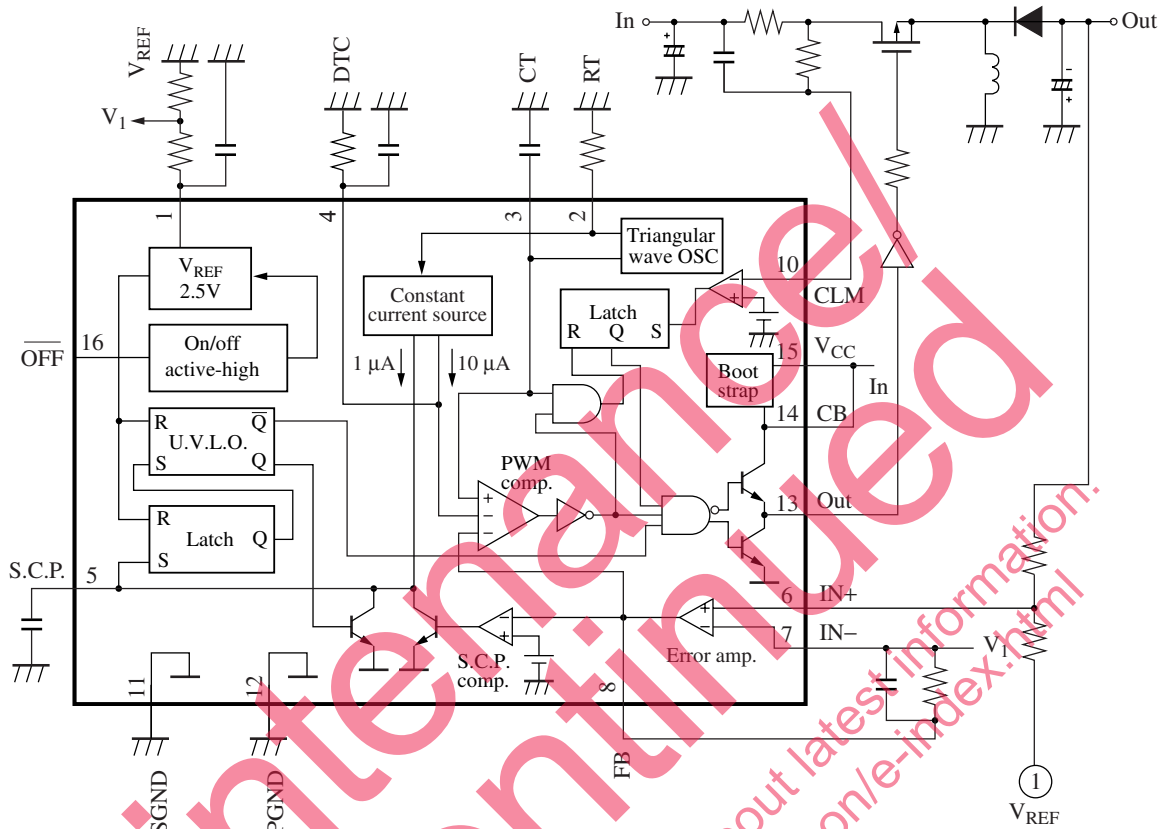

■ New Package Dimensions (Unit: mm)

- SOP016-P-0225E (Lead-free package)

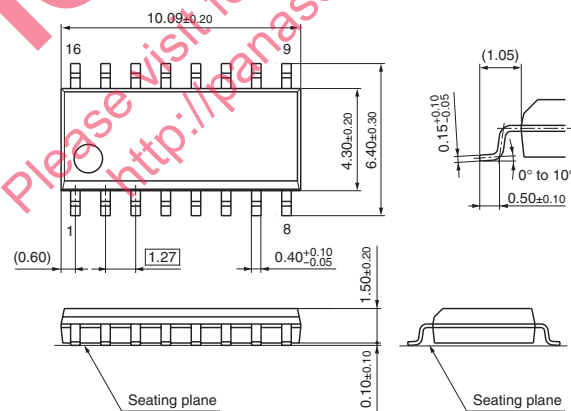

Request for your special attention and precautions in using the technical information and semiconductors described in this book

- (1) If any of the products or technical information described in this book is to be exported or provided to non-residents, the laws and regulations of the exporting country, especially, those with regard to security export control, must be observed.
- (2) The technical information described in this book is intended only to show the main characteristics and application circuit examples of the products, and no license is granted under any intellectual property right or other right owned by our company or any other company. Therefore, no responsibility is assumed by our company as to the infringement upon any such right owned by any other company which may arise as a result of the use of technical information described in this book.
- (3) The products described in this book are intended to be used for standard applications or general electronic equipment (such as office equipment, communications equipment, measuring instruments and household appliances).
Consult our sales staff in advance for information on the following applications:
 - Special applications (such as for airplanes, aerospace, automobiles, traffic control equipment, combustion equipment, life support systems and safety devices) in which exceptional quality and reliability are required, or if the failure or malfunction of the products may directly jeopardize life or harm the human body.
 - Any applications other than the standard applications intended.
- (4) The products and product specifications described in this book are subject to change without notice for modification and/or improvement. At the final stage of your design, purchasing, or use of the products, therefore, ask for the most up-to-date Product Standards in advance to make sure that the latest specifications satisfy your requirements.
- (5) When designing your equipment, comply with the range of absolute maximum rating and the guaranteed operating conditions (operating power supply voltage and operating environment etc.). Especially, please be careful not to exceed the range of absolute maximum rating on the transient state, such as power-on, power-off and mode-switching. Otherwise, we will not be liable for any defect which may arise later in your equipment.
 - Even when the products are used within the guaranteed values, take into the consideration of incidence of break down and failure mode, possible to occur to semiconductor products. Measures on the systems such as redundant design, arresting the spread of fire or preventing glitch are recommended in order to prevent physical injury, fire, social damages, for example, by using the products.
- (6) Comply with the instructions for use in order to prevent breakdown and characteristics change due to external factors (ESD, EOS, thermal stress and mechanical stress) at the time of handling, mounting or at customer's process. When using products for which damp-proof packing is required, satisfy the conditions, such as shelf life and the elapsed time since first opening the packages.
- (7) This book may be not reprinted or reproduced whether wholly or partially, without the prior written permission of Matsushita Electric Industrial Co., Ltd.