

# M5M34050P/FP M5M34051P/FP

DUAL RS-422A TRANSCEIVER

## DESCRIPTION

The M5M34050P/FP and M5M34051P/FP are semiconductor integrated circuits each with two differential drivers and differential receivers fulfilling the RS-422A EIA Standards.

## FEATURES

### [Common]

- Single 5V power supply
- Wide operating temperature range  
( $T_a = -20 \sim +75^\circ\text{C}$ )

- Both DIP and SOP packages are available.

### [Driver]

- Termination resistance of 100  $\Omega$  can be connected between outputs.
- High output impedance when power is off.
- Includes output control input

### [Receiver]

- High input sensitivity ( $\pm 200\text{mV}$  max.)
- Hysteresis input (50mV typ.)
- High input impedance (12k $\Omega$  min.)
- When input is open, output is "H" (failsafe function).
- Includes output control input (M5M34050P/FP)

## APPLICATION

HDD, LBP, printers, POS and other digital equipment high-speed data transmission interfaces.

## FUNCTIONAL DESCRIPTION

The drivers and the receivers have the same characteristics as the M5A26LS31P and the M5A26LS32AP, respectively.

The driver input, receiver output, and the two output control inputs have electrical characteristics equivalent to LSTTL, enabling direct drive of TTL ICs. The M5M34050P/FP has independent output control inputs DE and  $\overline{\text{RE}}$  for the driver and receiver, respectively, and the same control signal can be applied to these to alternately enable and disable the driver and receiver.

The M5M34051P/FP has separate output control inputs 1DE and 2DE and 1RE and 2RE.

## PIN CONFIGURATION (TOP VIEW)

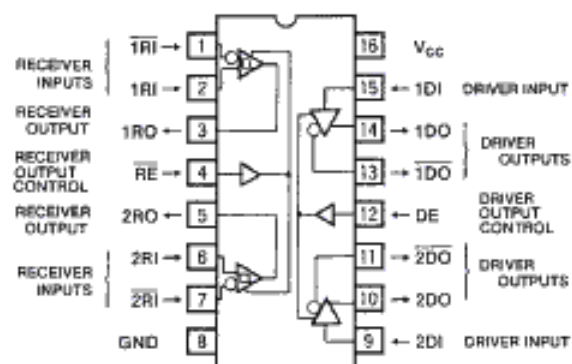

OUTLINE 16P4 (M5M34050P)  
16P2N-A (M5M34050FP)

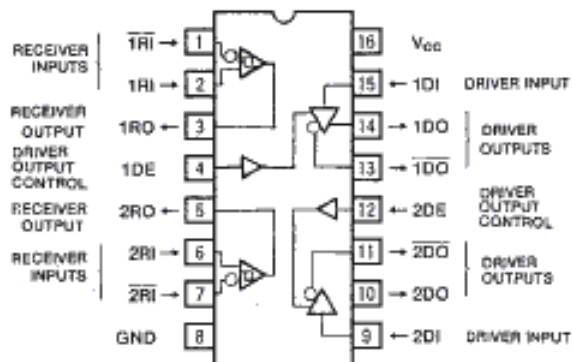

OUTLINE 16P4 (M5M34051P)  
16P2N-A (M5M34051FP)

## FUNCTION TABLE

### (1) Driver

DI	DE	DO	$\overline{\text{DO}}$
L	H	L	H
H	H	H	L
X	L	Z	Z

### (2) Receiver

$V_{IO}$	RI	$\overline{\text{RI}}$	RE	RO
$V_{IO} > +0.2\text{V}$			L	H
$-0.2\text{V} < V_{IO} < 0.2\text{V}$			L	*
$V_{IO} < -0.2\text{V}$			L	L
X			H	Z

Note 1 : X : Irrelevant  
Z : high impedance  
\* : Output status unspecified  
 $V_{IO}$  : ( $\overline{\text{RI}}$  applied voltage) - ( $\text{RI}$  applied voltage)

ABSOLUTE MAXIMUM RATINGS ( $T_a = -20 \sim +75^\circ\text{C}$  unless otherwise noted)

Symbol	Parameter	Conditions	Ratings		Unit
			Min.	Max.	
$V_{CC}$	Supply voltage		-0.5	+7	V
$V_i$	Input voltage	RI, $\bar{R}i$	-20	+20	V
		Other than above	-0.5	+7	
$V_{IP}$	Voltage between inputs	RI, $\bar{R}i$	-20	+20	V
$V_O$	Output voltage	When output is in high impedance condition	-0.5	+5.5	V
$P_d$	Power dissipation	DIP	$T_a = 25^\circ\text{C}$ (Note 2)		1000
		SOP	When mounted on PCB, $T_a = 25^\circ\text{C}$ (Note 3)		900
$T_{stg}$	Storage temperature range		-65	+150	$^\circ\text{C}$

Note 2 : When  $T_a \geq 40^\circ\text{C}$ , derate as 9mW/ $^\circ\text{C}$ .3 : When  $T_a \geq 25^\circ\text{C}$ , derate as 7.2mW/ $^\circ\text{C}$ .RECOMMENDED OPERATING CONDITIONS ( $T_a = -20 \sim +75^\circ\text{C}$  unless otherwise noted)

Symbol	Parameter	Conditions	Limits			Unit	
			Min.	Typ.	Max.		
$V_{CC}$	Supply voltage		4.75	5	5.25	V	
$I_{OH}$	"H" output current	DO, $\bar{D}O$	$V_{OH} \geq 2.5\text{V}$		0	-20	mA
		RO	$V_{OH} \geq 2.7\text{V}$		0	-400	$\mu\text{A}$
$I_{OL}$	"L" output current	DO, $\bar{D}O$	$V_{OL} \leq 0.5\text{V}$		0	20	mA
		RO	$V_{OL} \leq 0.45\text{V}$		0	8	
$V_{IO}$	Common mode input voltage (Note 4)		-7		+7	V	
$T_{opr}$	Operating temperature range	DIP	-20		+75	$^\circ\text{C}$	
		SOP	When IC is mounted on PCB		-20	+75	

Note 4 : The common mode input voltage is the average value of the voltage applied to RI and  $\bar{R}i$ .ELECTRICAL CHARACTERISTICS ( $T_a = -20 \sim +75^\circ\text{C}$  unless otherwise noted)

&lt;Driver Section&gt;

Symbol	Parameter	Test conditions	Limits			Unit	
			Min.	Typ.*	Max.		
$V_{IH}$	"H" input voltage		2			V	
$V_{IL}$	"L" input voltage				0.8	V	
$V_{IK}$	Input clamp voltage	$V_{CC} = 4.75\text{V}$ , $I_{IK} = -18\text{mA}$			-1.5	V	
$V_{OH}$	"H" output voltage	$V_{CC} = 4.75\text{V}$ , $I_{OH} = -20\text{mA}$	2.5	3.1		V	
$V_{OL}$	"L" output voltage	$V_{CC} = 4.75\text{V}$ , $I_{OL} = 20\text{mA}$		0.32	0.5	V	
$I_{OZL}$	"L" output current when off	$V_{CC} = 5.25\text{V}$ , $V_O = 0.5\text{V}$			-20	$\mu\text{A}$	
$I_{OZH}$	"H" output current when off	$V_{CC} = 5.25\text{V}$ , $V_O = 2.5\text{V}$			20	$\mu\text{A}$	
$I_{X+}$	Output leak current when power off	$V_{CC} = 0\text{V}$	$V_O = 5\text{V}$			50	$\mu\text{A}$
$I_{X-}$			$V_O = -0.25\text{V}$			-50	$\mu\text{A}$
$I_{IH}$	"H" input current	$V_{CC} = 5.25\text{V}$	$V_i = 2.0\text{V}$			0.1	mA
			$V_i = 2.7\text{V}$			20	$\mu\text{A}$
$I_{IL}$	"L" input current	$V_{CC} = 5.25\text{V}$ , $V_i = 0.4\text{V}$		-0.05	-0.36	mA	
$I_{OS}$	Output short current (Note 5)	$V_{CC} = 5.25\text{V}$	-30		-150	mA	

Note 5 : Measurement is conducted over a short period of time, and more than 2 outputs should not be shorted at a time.

**M5M34050P/FP**  
**M5M34051P/FP**

**DUAL RS-422A TRANSCEIVER**

<Receiver Section>

Symbol	Parameter		Test conditions	Limits			Unit
				Min.	Typ.*	Max.	
$V_{TH}$	High threshold voltage	$R_I, \bar{R}_I$	$V_{OH}=2.7V, I_{OH}=-400\mu A$ $V_{IO}=V_{TH}$			0.2	V
$V_{TL}$	Low threshold voltage	$R_I, \bar{R}_I$	$V_{OL}=0.45V, I_{OH}=8mA$ $V_{IO}=V_{TL}$	-0.2			V
$V_{T+}$ $V_{T-}$	Hysteresis width (Note 5)	$R_I, \bar{R}_I$			50		mV
$V_{IH}$	"H" input voltage	$\bar{R}_E$		2			V
$V_{IL}$	"L" input voltage	$\bar{R}_E$				0.8	V
$V_{IK}$	Input clamp voltage	$\bar{R}_E$	$V_{CC}=4.75V, I_{IK}=-18mA$			-1.5	V
$V_{OH}$	"H" output voltage		$V_{CC}=4.75V, V_{I(RE)}=V_L$ $V_{IO}=0.4V, I_{OL}=-400\mu A$	2.7	3.5		V
$V_{OL}$	"L" output voltage		$V_{CC}=4.75V$ $V_{IO}=-0.4V$ $V_{I(RE)}=V_L$	$I_L=4mA$ $I_{OL}=8mA$		0.4 0.31 0.45	V
$I_{OZL}$	"L" output current when off		$V_{CC}=5.25V, V_O=0.4V$ $V_{IO}=3V$			20	$\mu A$
$I_{OZH}$	"H" output current when off		$V_{CC}=5.25V, V_O=2.4V$ $V_{IO}=3V$			-20	$\mu A$
$I_I$	Input current	$R_I, \bar{R}_I$	$0 \leq V_{CC} \leq 5.25V, V_I=12V$ $0 \leq V_{CC} \leq 5.25V, V_I=-7V$			1.0 -0.8	mA
$I_{IH}$	"H" input current	$\bar{R}_E$	$V_I=7.0V$ $V_I=2.7V$			100 20	$\mu A$
$I_{IL}$	"L" input current	$\bar{R}_E$	$V_I=0.4V$			-0.36	mA
$I_{OS}$	Output short current (Note 5)		$V_{CC}=5.25V$	-15		-85	mA

Note 5 : The hysteresis width is the difference between the threshold voltage  $V_{T+}$  and  $V_{T-}$  in the positive and negative directions, respectively.

<Power Supply Section>

Symbol	Parameter	Test conditions	Limits			Unit
			Min.	Typ.*	Max.	
$I_{CC}$	Supply current	$V_{CC}=5.25V$ , output enable condition		58	90	mA

\* : All typical values are at  $V_{CC}=5V$  and  $T_a=25^\circ C$ .

**M5M34050P/FP**  
**M5M34051P/FP**

**DUAL RS-422A TRANSCEIVER**

**SWITCHING CHARACTERISTICS** ( $V_{CC}=5V$  and  $T_A=25^\circ C$ )

<Driver Section>

Symbol	Parameter	Test conditions	Limits			Unit
			Min.	Typ.	Max.	
$t_{PLH}$	Outputs "L-H", "H-L" propagation time, from input DI to output DO, $\overline{DO}$	$C_L=30pF$		11	20	ns
$t_{PHL}$				11	20	ns
Skew						6
$t_{PZH}$	"H" output enable time	$C_L=30pF$ $R_L=75\Omega$ to GND		8	40	ns
$t_{PZL}$	"L" output enable time	$C_L=30pF$ $R_L=180\Omega$ to $V_{CC}$		18	45	ns
$t_{PHZ}$	"H" output disable time	$C_L=10pF$ $R_L=75\Omega$ to GND		10	30	ns
$t_{PLZ}$	"L" output disable time	$C_L=10pF$ $R_L=180\Omega$ to $V_{CC}$		11	35	ns

<Receiver Section>

Symbol	Parameter	Test conditions	Limits			Unit
			Min.	Typ.	Max.	
$t_{PLH}$	Outputs "L-H", "H-L" propagation time, from inputs RI and $\overline{RI}$ to output RO	$C_L=15pF$		19	40	ns
$t_{PHL}$				29	40	ns
$t_{PZH}$	"H" output enable time	$C_L=15pF$		10	30	ns
$t_{PZL}$	"L" output enable time	$C_L=15pF$		16	30	ns
$t_{PHZ}$	"H" output disable time	$C_L=15pF$		18	35	ns
$t_{PLZ}$	"L" output disable time	$C_L=15pF$		16	35	ns

**TIMING REQUIREMENTS** ( $V_{CC}=5V$ ,  $T_A=25^\circ C$ )

Symbol	Parameter	Test conditions	Limits			Unit
			Min.	Typ.	Max.	
$t_r, t_f$	Control input rise, fall time	RE, DE			1	$\mu s$

**TEST CIRCUIT**

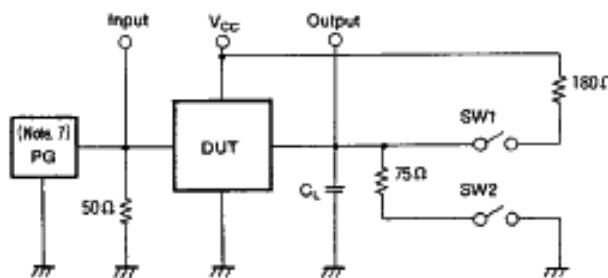

For driver section

Parameter	SW1	SW2	$C_L$
$t_{PLH}$	Open	Open	30pF
$t_{PHL}$	Open	Open	30pF
$t_{PZH}$	Open	Closed	30pF
$t_{PZL}$	Closed	Open	30pF
$t_{PHZ}$	Open	Closed	10pF
$t_{PLZ}$	Closed	Open	10pF

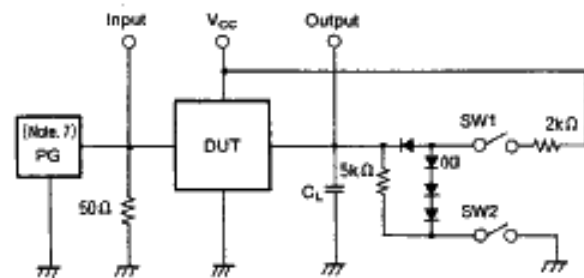

For receiver section

Parameter	SW1	SW2	$C_L$
$t_{PLH}$	Open	Open	15pF
$t_{PHL}$	Open	Open	
$t_{PZH}$	Open	Closed	
$t_{PZL}$	Closed	Open	
$t_{PHZ}$	Closed	Closed	
$t_{PLZ}$	Closed	Closed	

Note 7 : PG (pulse generator) output conditions are as follows.

- Rising time :  $t_r \leq 15ns$
- Falling time :  $t_f \leq 6ns$
- Repeat frequency : PRR= 1 MHz
- Pulse amp. :  $V_p = 3 V_{p-p}$
- Output impedance :  $Z_o = 50\Omega$

**TIMING DIAGRAM**

Driver Section

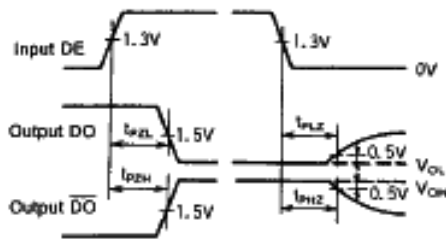
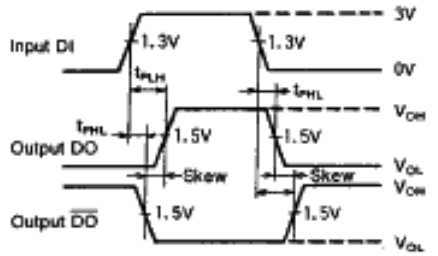

Receiver Section

