

DATA SHEET



TEA6845H New In Car Entertainment (NICE) car radio

Product specification
Supersedes data of 2001 Apr 12

2003 Feb 04

New In Car Entertainment (NICE) car radio**TEA6845H**

CONTENTS	14	PACKAGE OUTLINE	
1	FEATURES	15	SOLDERING
2	GENERAL DESCRIPTION	15.1	Introduction to soldering surface mount packages
3	QUICK REFERENCE DATA	15.2	Reflow soldering
4	ORDERING INFORMATION	15.3	Wave soldering
5	BLOCK DIAGRAM	15.4	Manual soldering
6	PINNING	15.5	Suitability of surface mount IC packages for wave and reflow soldering methods
7	FUNCTIONAL DESCRIPTION	16	DATA SHEET STATUS
7.1	Oscillators	17	DEFINITIONS
7.1.1	VCO	18	DISCLAIMERS
7.1.2	Crystal oscillator	19	PURCHASE OF PHILIPS I²C COMPONENTS
7.1.3	PLL		
7.2	FM signal channel		
7.2.1	DAA		
7.2.2	FM I/Q mixer		
7.2.3	FM keyed AGC		
7.2.4	FM IF amplifiers		
7.2.5	FM demodulator		
7.3	AM signal channel		
7.3.1	AM tuner including mixer 1 and mixer 2		
7.3.2	AM RF AGC and IF2 AGC		
7.3.3	AM detector		
7.3.4	AM AF or IF2 switch		
7.3.5	AM noise detector and blanker		
7.3.6	FM and AM level detector		
7.4	Test mode		
8	LIMITING VALUES		
9	THERMAL CHARACTERISTICS		
10	DC CHARACTERISTICS		
11	AC CHARACTERISTICS		
12	I ² C-BUS PROTOCOL		
12.1	I ² C-bus specification		
12.1.1	Test mode		
12.1.2	Data transfer		
12.1.3	I ² C-bus pull-up resistors		
12.1.4	Frequency setting		
12.2	I ² C-bus protocol		
12.2.1	Data transfer mode and IC address		
12.2.2	Write mode: data byte 1		
12.2.3	Write mode: data byte 2		
12.2.4	Write mode: data byte 3		
12.2.5	Write mode: data byte 4		
12.2.6	Write mode: data byte 5		
12.2.7	Write mode: data byte 6		
12.2.8	Read mode: data byte 1		
13	TEST AND APPLICATION INFORMATION		

New In Car Entertainment (NICE) car radio

TEA6845H

1 FEATURES

- FM mixer for conversion of FM RF from 65 to 108 MHz to IF of 10.7 MHz; the mixer provides inherent image rejection
- FM RF mixer can be set to receive weather band radio up to 162.55 MHz; weather band radio flag output
- AM mixer 1 for conversion of AM RF to AM IF1 of 10.7 MHz
- LC tuner oscillator providing mixer frequencies for FM mixer and AM mixer 1
- AM mixer 2 for conversion of AM IF1 to AM IF2 of 450 kHz
- Crystal oscillator providing mixer frequencies for AM mixer 2 and reference for synthesizer PLL, IF count, timing for Radio Data System (RDS) update and reference frequency for car audio signal processor ICs
- Fast synthesizer PLL tuning system with local control for inaudible RDS updating
- Timing function for RDS update algorithm and control signal output for car audio signal processor ICs (TEA688x, SAA77xx or TEF689x)
- Digital auto alignment circuit for conversion of LC oscillator tuning voltage to controlled alignment voltage of FM antenna tank circuit
- AGC PIN diode drive circuit for FM RF AGC; AGC detection at FM mixer input; the AGC PIN diode drive can be activated by the I²C-bus as a local or distance function; AGC threshold is a programmable and keyed function switchable via the I²C-bus
- FM IF linear amplifiers with high dynamic input range
- FM quadrature demodulator with automatic centre frequency adjustment and Total Harmonic Distortion (THD) compensation
- Level detector for AM and FM with temperature compensated output voltage; starting point and slope of level output is programmable via the I²C-bus
- AM RF PIN diode drive circuit; AGC threshold detection at AM mixer 1 and IF2 AGC input; threshold is programmable via the I²C-bus; AM IF2 AGC and demodulator
- AM AF output switchable to provide AM IF2 for AM stereo decoder
- AM noise blanker with blanking at AM IF2
- Several test modes available for fast IC and system tests.

**2 GENERAL DESCRIPTION**

The TEA6845H is a single IC with car radio tuner for AM and FM intended for microcontroller tuning with the I²C-bus. It provides the following functions:

- AM double conversion receiver for LW, MW and SW (31 m, 41 m and 49 m bands) with IF1 = 10.7 MHz and IF2 = 450 kHz
- FM single conversion receiver with integrated image rejection for IF = 10.7 MHz capable of selecting US FM, US weather, Europe FM, East Europe FM and Japan FM bands.

3 ORDERING INFORMATION

TYPE NUMBER	PACKAGE		
	NAME	DESCRIPTION	VERSION
TEA6845H	QFP64	plastic quad flat package; 64 leads (lead length 1.95 mm); body 14 × 20 × 2.8 mm	SOT319-2

New In Car Entertainment (NICE) car radio

TEA6845H

4 QUICK REFERENCE DATA

SYMBOL	PARAMETER	CONDITIONS	MIN.	TYP.	MAX.	UNIT
$V_{DDA(n)}$	analog supply voltage 1, 3, 4, 5 and 6		8	8.5	9	V
$I_{DDA(tot)}$	total analog supply current 1, 3, 4, 5 and 6	FM mode	45	56	67	mA
		AM mode	39	49	59	mA
V_{DDA2}	analog supply voltage 2		4.75	5	5.25	V
I_{DDA2}	analog supply current 2	FM mode	6.5	8.1	9.8	mA
		AM mode	4.7	5.9	7.1	mA
V_{DDD}	digital supply voltage		4.75	5	5.25	V
I_{DDD}	digital supply current	FM mode	18	23	28	mA
		AM mode	18	23	28	mA
$f_{AM(ant)}$	AM input frequency	LW	0.144	–	0.288	MHz
		MW	0.522	–	1.710	MHz
		SW	5.85	–	9.99	MHz
$f_{FM(ant)}$	FM input frequency		65	–	108	MHz
$f_{FM(WB)(ant)}$	FM weather band input frequency		162.4	–	162.55	MHz
T_{amb}	ambient temperature		–40	–	+85	°C
AM overall system parameters (1 × SFE10.7MS3; 1 × SFR450H)						
(S+N)/N	signal plus noise-to-noise ratio	$m = 0.3$	–	58	–	dB
THD	total harmonic distortion	$m = 0.8$	–	0.3	–	%
		$m = 0.9$	–	0.5	–	%
FM overall system parameters (3 × SFE10.7MS3)						
(S+N)/N	signal plus noise-to-noise ratio	$\Delta f = 22.5$ kHz; de-emphasis = 50 μ s	–	65	–	dB
THD	total harmonic distortion	$\Delta f = 75$ kHz	–	0.6	1	%

New In Car Entertainment (NICE) car radio

TEA6845H

5 BLOCK DIAGRAM

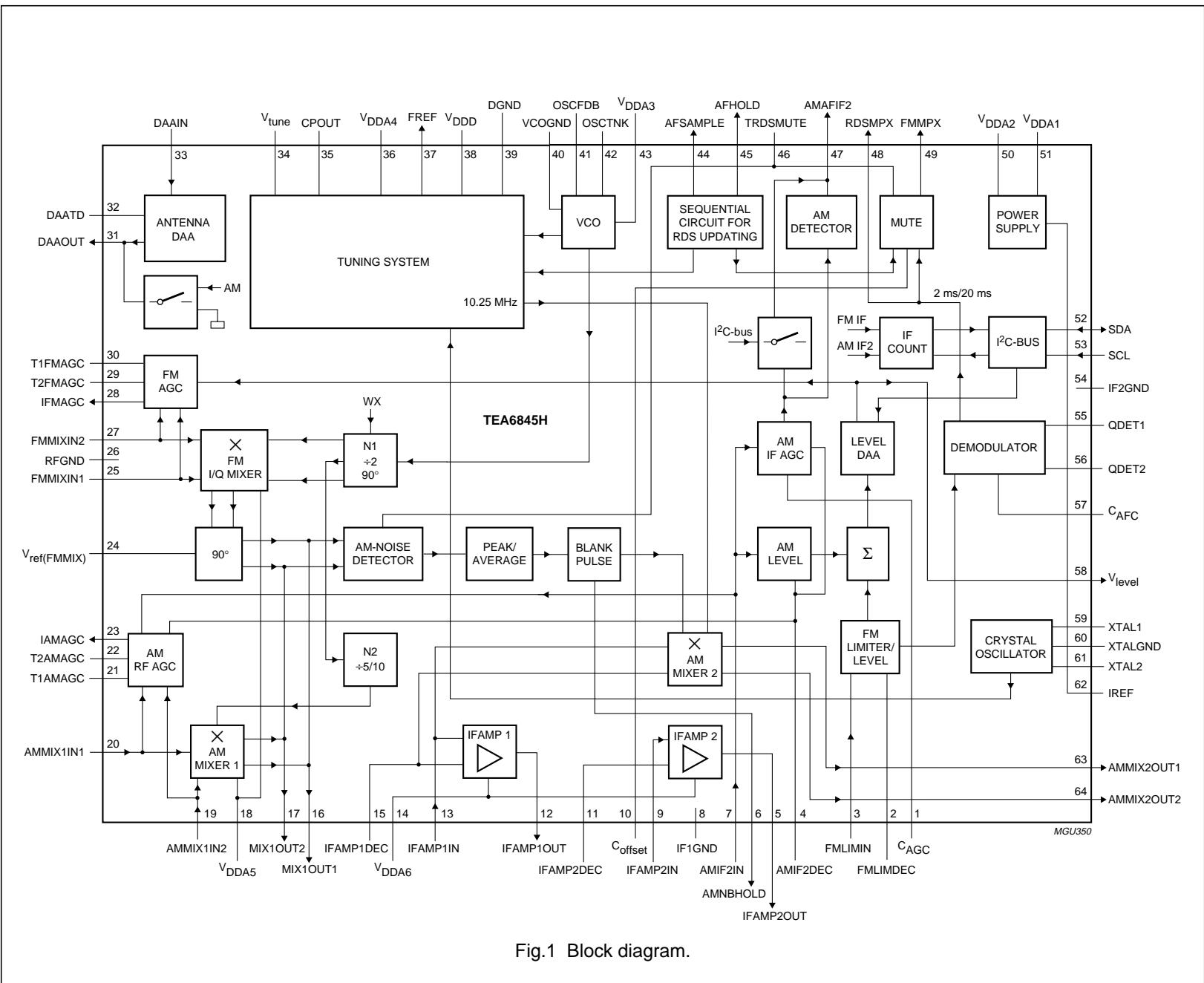

Fig.1 Block diagram.

New In Car Entertainment (NICE) car radio

TEA6845H

6 PINNING

SYMBOL	PIN	DESCRIPTION
C _{AGC}	1	AM IF AGC capacitor
FMLIMDEC	2	FM limiter decoupling
FMLIMIN	3	FM limiter input (10.7 MHz)
AMIF2DEC	4	decoupling for AM IF2 input
IFAMP2OUT	5	IF amplifier 2 output (10.7 MHz)
AMNBHOLD	6	AM noise blanker threshold
AMIF2IN	7	AM IF2 input (450 kHz) for demodulator AGC and AM level detector
IF1GND	8	AM IF1 ground
IFAMP2IN	9	IF amplifier 2 input (10.7 MHz)
C _{offset}	10	DC feedback for offset compensation RDS mute
IFAMP2DEC	11	IF amplifier 2 decoupling and AGC capacitor for AM noise blanker
IFAMP1OUT	12	IF amplifier 1 output (10.7 MHz)
IFAMP1IN	13	IF amplifier 1 and AM mixer 2 input (10.7 MHz)
V _{DDA6}	14	analog supply voltage 6 (8.5 V) for IF amplifier 1 and 2
IFAMP1DEC	15	AM mixer 2 and FM IF amplifier 1 decoupling
MIX1OUT1	16	FM mixer and AM mixer 1 IF output 1 (10.7 MHz)
MIX1OUT2	17	FM mixer and AM mixer 1 IF output 2 (10.7 MHz)
V _{DDA5}	18	analog supply voltage 5 (8.5 V) for FM mixer and AM mixer 1
AMMIX1IN2	19	AM mixer 1 input 2
AMMIX1IN1	20	AM mixer 1 input 1
T1AMAGC	21	1st time constant of AM front-end AGC
T2AMAGC	22	2nd time constant of AM front-end AGC
IAMAGC	23	PIN diode drive current output of AM front-end AGC
V _{ref(FMMIX)}	24	reference voltage for FM I/Q mixer
FMMIXIN1	25	FM RF mixer input 1
RFGND	26	RF ground
FMMIXIN2	27	FM RF mixer input 2
IFMAGC	28	PIN diode drive current output of FM front-end AGC
T2FMAGC	29	2nd time constant of FM front-end AGC
T1FMAGC	30	1st time constant of FM front-end AGC
DAAOUT	31	output of digital auto alignment circuit for antenna tank circuit
DAATD	32	temperature compensation diode for digital auto alignment circuit for antenna tank circuit
DAAIN	33	input of digital auto alignment circuit for antenna tank circuit
V _{tune}	34	tuning voltage
CPOUT	35	charge pump output
V _{DDA4}	36	analog supply voltage 4 (8.5 V) for tuning PLL
FREF	37	reference frequency output for signal processor IC
V _{DDD}	38	digital supply voltage (5 V)
DGND	39	digital ground
VCOGND	40	VCO ground

New In Car Entertainment (NICE) car radio

TEA6845H

SYMBOL	PIN	DESCRIPTION
OSCFDB	41	VCO feedback
OSCTNK	42	VCO tank circuit
V _{DDA3}	43	analog supply voltage 3 (8.5 V) for VCO
AFSAMPLE	44	AF sample flag output for car audio signal processor IC
AFHOLD	45	AF hold flag output for car audio signal processor IC
TRDSMUTE	46	time constant for RDS update mute
AMAFIF2	47	AM demodulator AF output or IF2 output for AM stereo (multiplexed by I ² C-bus)
RDSMPX	48	MPX output for RDS decoder and signal processor (not muted)
FMMPX	49	FM demodulator MPX output
V _{DDA2}	50	analog supply voltage 2 (5 V) for on-chip power supply
V _{DDA1}	51	analog supply voltage 1 (8.5 V) for on-chip power supply
SDA	52	I ² C-bus data line input and output
SCL	53	I ² C-bus clock line input
IF2GND	54	AM IF2 ground
QDET1	55	quadrature demodulator tank 1
QDET2	56	quadrature demodulator tank 2
C _{AFC}	57	FM demodulator AFC capacitor
V _{level}	58	level voltage output for AM and FM
XTAL1	59	crystal oscillator 1
XTALGND	60	crystal oscillator ground
XTAL2	61	crystal oscillator 2
IREF	62	reference current for power supply
AMMIX2OUT1	63	AM mixer 2 output 1 (450 kHz)
AMMIX2OUT2	64	AM mixer 2 output 2 (450 kHz)

New In Car Entertainment (NICE) car radio

TEA6845H

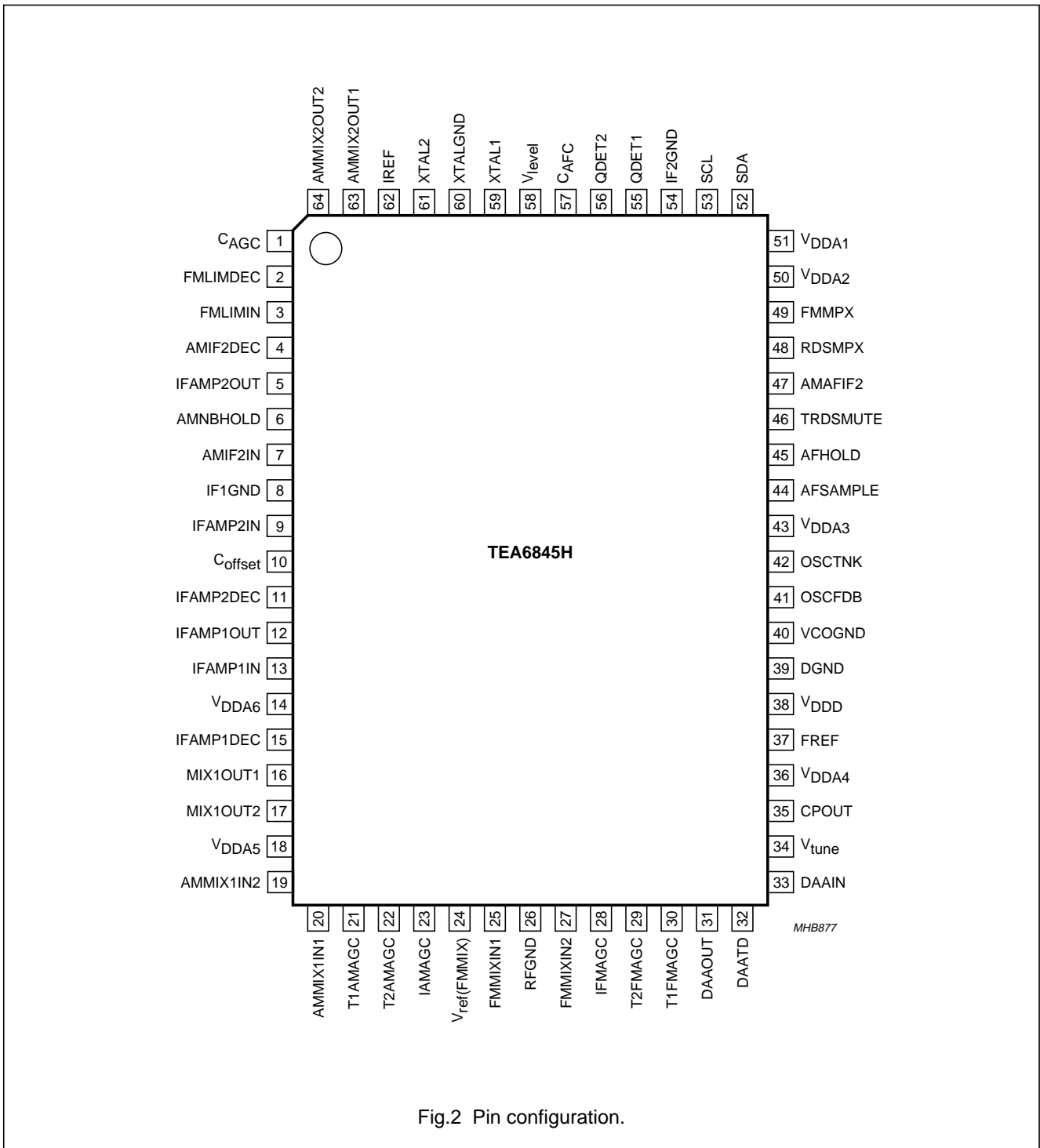

Fig.2 Pin configuration.

New In Car Entertainment (NICE) car radio

TEA6845H

7 FUNCTIONAL DESCRIPTION

7.1 Oscillators

7.1.1 VCO

The L and C tuned VCO provides the local oscillator signal for both FM and AM mixer 1. It has a frequency range of 151.2 to 248.2 MHz.

7.1.2 CRYSTAL OSCILLATOR

The crystal oscillator provides a 20.5 MHz signal that is used for:

- Reference frequency for frequency synthesizer PLL
- Local oscillator for AM mixer 2
- Reference frequency for the IF counter
- Timing signal for the RDS update algorithm
- Reference frequency (75.4 kHz) for the TEA6880H (car audio signal processor - CASP) or TEF6890H (car radio integrated signal processor).

7.1.3 PLL

Fast synthesizer PLL tuning system with local control for inaudible RDS updating.

7.2 FM signal channel

7.2.1 DAA

FM RF Digital Auto Alignment (DAA) circuitry for the conversion of the VCO tuning voltage to a controlled alignment voltage for the FM antenna tank circuit.

7.2.2 FM I/Q MIXER

FM quadrature mixer converts FM RF (65 to 162.55 MHz) to IF of 10.7 MHz. The FM mixer provides inherent image rejection and high RF sensitivity.

It is capable of tuning the US FM, US weather, Europe FM, Japan FM and East Europe FM bands:

- US FM = 87.9 to 107.9 MHz
- US weather FM = 162.4 to 162.55 MHz
- Europe FM = 87.5 to 108 MHz
- Japan FM = 76.0 to 91 MHz
- East Europe FM = 65.8 to 74 MHz.

7.2.3 FM KEYED AGC

FM contains keyed wide-band RF AGC. AGC detection occurs at the FM mixer. The wide-band RF signal switches a narrow band signal (IF) from the FM IF level detector circuitry that controls the FM RF AGC block.

It includes an AGC PIN diode drive circuit for the FM RF AGC. The PIN diode drive can be activated via the I²C-bus as a local or distance function.

The AGC threshold is programmable and the keyed AGC function is switchable via the I²C-bus.

7.2.4 FM IF AMPLIFIERS

The two FM IF amplifiers provide 10 dB and 4 dB amplification with high linearity and dynamic range.

7.2.5 FM DEMODULATOR

The FM quadrature demodulator includes automatic centre frequency adjustment and THD compensation.

7.3 AM signal channel

7.3.1 AM TUNER INCLUDING MIXER 1 AND MIXER 2

The AM tuner is realized in a double conversion technique and is capable of selecting LW, MW and SW bands.

AM mixer 1 converts AM RF to IF1 of 10.7 MHz, while AM mixer 2 converts IF1 of 10.7 MHz to IF2 of 450 kHz:

- LW = 144 to 288 kHz
- MW = 530 to 1710 kHz (US AM band)
- SW = 5.85 to 9.99 MHz (including the 31 m, 41 m and 49 m bands).

7.3.2 AM RF AGC AND IF2 AGC

The AM RF includes a PIN diode drive circuit. The threshold detection points for AM AGC are performed at AM mixer 1 and AM IF2. AGC thresholds are programmable via the I²C-bus.

7.3.3 AM DETECTOR

The AM detector provides AM level information and AM AF or AM IF2.

7.3.4 AM AF OR IF2 SWITCH

The AM output provides either a detected AM AF or the corresponding AM IF2 signal. The IF2 signal can be used for AM stereo decoder processing.

New In Car Entertainment (NICE) car radio

TEA6845H

7.3.5 AM NOISE DETECTOR AND BLANKER

The detection point for the AM noise blanker is the output stage of AM mixer 1, while blanking is realized at the output of the mixer 2.

Trigger sensitivity can be modified by changing the resistor value at pin AMNBHOLD.

7.3.6 FM AND AM LEVEL DETECTOR

FM and AM level detectors provide the temperature compensated output voltage. The starting points and slopes of the level detector outputs are programmable via the I²C-bus.

7.4 Test mode

The test mode of the IC is activated by:

- Sending the test byte (byte 5) to the IC
- Connecting pin FREF through a 100 k Ω resistor to V_{DDA1}
- Applying 50 μ A to pin FREF.

If the test mode is enabled by pin FREF:

- The settling time of the AM IF2 AGC is reduced to less than 100 ms in the nominal application
- The digital-to-analog converters for the antenna DAA and the level DAA can be clocked directly by the SCL line of the I²C-bus
- The output at pin FREF can be selected by the I²C-bus: TEA6880H or TEF6890H reference frequency, PLL reference frequency or PLL programmable divider output frequency
- The RDS update control circuit can be clocked directly via pin DAATD
- Pin T1AMAGC can be used to enable the load PLL circuit of the RDS update control circuit
- Charge pumps can be set into 3-state mode.

8 LIMITING VALUES

In accordance with the Absolute Maximum Rating System (IEC 60134).

SYMBOL	PARAMETER	CONDITIONS	MIN.	MAX.	UNIT
V _{DDA1}	analog supply voltage 1 for on-chip power supply		-0.3	+10	V
V _{DDA2}	analog supply voltage 2 for on-chip power supply		-0.3	+6.5	V
V _{DDA3}	analog supply voltage 3 for VCO		-0.3	+10	V
V _{DDA4}	analog supply voltage 4 for tuning PLL		-0.3	+10	V
V _{DDA5}	analog supply voltage 5 for FM and AM RF		-0.3	+10	V
V _{DDA6}	analog supply voltage 6 for IF amplifier 1 and 2		-0.3	+10	V
V _{DDD}	digital supply voltage		-0.3	+6.5	V
$\Delta V_{DD8.5-DD5}$	difference between any 8.5 V supply voltage and any 5 V supply voltage	note 1	-0.3	-	V
T _{stg}	storage temperature		-55	+150	°C
T _{amb}	ambient temperature		-40	+85	°C
V _{es}	electrostatic handling voltage	note 2	-200	+200	V
		note 3	-2000	+2000	V

Notes

1. To avoid damage and wrong operation it is necessary to keep all 8.5 V supply voltages at a higher level than any 5 V supply voltage. This is also necessary during power-on and power-down sequences. Precautions have to be provided in such a way that interference cannot pull the 8.5 V supply down below the 5 V supply.
2. Machine model (R = 0 Ω , C = 200 pF).
3. Human body model (R = 1.5 k Ω , C = 100 pF).

New In Car Entertainment (NICE) car radio

TEA6845H

9 THERMAL CHARACTERISTICS

SYMBOL	PARAMETER	CONDITIONS	VALUE	UNIT
$R_{th(j-a)}$	thermal resistance from junction to ambient	in free air	48	K/W

10 DC CHARACTERISTICS

$V_{DDA1} = V_{DDA3} = V_{DDA4} = V_{DDA5} = V_{DDA6} = 8.5$ V; $V_{DDA2} = 5$ V; $V_{DDD} = 5$ V; $T_{amb} = 25$ °C; unless otherwise specified.

SYMBOL	PARAMETER	CONDITIONS	MIN.	TYP.	MAX.	UNIT
Supply voltage						
$V_{DDA(n)}$	analog supply voltage 1, 3, 4, 5 and 6		8	8.5	9	V
V_{DDA2}	analog supply voltage 2		4.75	5	5.25	V
V_{DDD}	digital supply voltage		4.75	5	5.25	V
Supply current in FM mode						
I_{DDD}	digital supply current		18	23	28	mA
I_{DDA1}	analog supply current 1 for on-chip power supply		–	15	–	mA
I_{DDA2}	analog supply current 2 for on-chip power supply		6.5	8.1	9.8	mA
I_{DDA3}	analog supply current 3 for VCO		–	6.5	–	mA
I_{DDA4}	analog supply current 4 for tuning PLL	test mode; bit TMS3 = 1	–	2.9	–	mA
I_{DDA5}	analog supply current 5 for FM RF		–	5	–	mA
I_{DDA6}	analog supply current 6 for FM IF amplifier 1 and 2		10	12	14	mA
$I_{MIX1OUT1}$	bias current of FM mixer output 1		4.8	6	7.2	mA
$I_{MIX1OUT2}$	bias current of FM mixer output 2		4.8	6	7.2	mA
Supply current in AM mode						
I_{DDD}	digital supply current		18	23	28	mA
I_{DDA1}	analog supply current 1 for on-chip power supply		–	17.5	–	mA
I_{DDA2}	analog supply current 2 for on-chip power supply		4.7	5.9	7.1	mA
I_{DDA3}	analog supply current 3 for VCO		–	6.5	–	mA
I_{DDA4}	analog supply current 4 for tuning PLL	test mode; bit TMS3 = 1	–	1.6	–	mA
I_{DDA5}	analog supply current 5 for RF		–	1.8	–	mA
$I_{MIX1OUT1}$	bias current of AM mixer 1 output 1		4.8	6	7.2	mA
$I_{MIX1OUT2}$	bias current of AM mixer 1 output 2		4.8	6	7.2	mA
$I_{AMMIX2OUT1}$	bias current of AM mixer 2 output 1		3.6	4.5	5.4	mA
$I_{AMMIX2OUT2}$	bias current of AM mixer 2 output 2		3.6	4.5	5.4	mA
On-chip power supply reference current generator: pin IREF						
$V_{o(ref)}$	output reference voltage		4	4.25	4.5	V
R_o	output resistance		8	11	13	k Ω
$I_{o(max)}$	maximum output current		–100	–	+100	nA

New In Car Entertainment (NICE) car radio

TEA6845H

11 AC CHARACTERISTICS

$V_{DDA1} = V_{DDA3} = V_{DDA4} = V_{DDA5} = V_{DDA6} = 8.5 \text{ V}$; $V_{DDA2} = 5 \text{ V}$; $V_{DDD} = 5 \text{ V}$; $T_{\text{amb}} = 25 \text{ }^\circ\text{C}$; see Figs 9 and 10; unless otherwise specified.

SYMBOL	PARAMETER	CONDITIONS	MIN.	TYP.	MAX.	UNIT
Voltage controlled oscillator						
f_{osc}	oscillator frequency		151.2	–	248.2	MHz
C/N	carrier-to-noise ratio	$f_{\text{osc}} = 200 \text{ MHz}$; $\Delta f = 10 \text{ kHz}$	–	101	–	$\frac{\text{dBc}}{\sqrt{\text{Hz}}}$
RR	ripple rejection	$f_{\text{ripple}} = 100 \text{ Hz}$; $V_{\text{DDA3(ripple)}} = 100 \text{ mV (RMS)}$	–	97	–	dB
		$f_{\text{osc}} = 250 \text{ MHz}$	–	99	–	dB
		$f_{\text{osc}} = 200 \text{ MHz}$	–	99	–	dB
FEEDBACK INPUT: PIN OSCFDB						
$V_{i(\text{bias})}$	input bias voltage		2.2	2.8	3.4	V
TANK CIRCUIT OUTPUT: PIN OSCTNK						
V_{O}	DC output voltage		5	6.1	7.2	V
$V_{\text{O(rms)}}$	AC output voltage (RMS value)	$f_{\text{osc}} = 200 \text{ MHz}$	–	1.5	–	V
Crystal oscillator						
f_{xtal}	crystal frequency		20.4996	20.5	20.5004	MHz
R_{xtal}	crystal motional resistance	start of operating	–	–	500	Ω
C_{xtal}	crystal shunt capacitance		–	–	18	pF
C/N	carrier-to-noise ratio	$f_{\text{xtal}} = 20.5 \text{ MHz (10.25 MHz)}$; $\Delta f = 10 \text{ kHz}$	–	112	–	$\frac{\text{dBc}}{\sqrt{\text{Hz}}}$
CIRCUIT INPUTS: PINS XTAL1, XTAL2 AND XTALGND						
$V_{\text{xtal(rms)}}$	crystal voltage (RMS value)	note 1	–	350	–	mV
V_{XTAL1} , V_{XTAL2}	DC bias voltage		1.7	2.1	2.5	V
R_i	real part of input impedance	$V_{\text{XTAL1}} - V_{\text{XTAL2}} = 1 \text{ mV}$; note 1	–500	–	–	Ω
C_i	input capacitance	note 1	8	10	12	pF
I_{XTALGND}	crystal oscillator circuit current	start-up at $V_{\text{XTAL1}} = V_{\text{XTAL2}} = 2.1 \text{ V}$	–	9	–	mA
		operating at $V_{\text{XTAL1}} - V_{\text{XTAL2}} = \pm 400 \text{ mV}$	–	1.5	–	mA
Oscillator divider N1						
N1	oscillator divider ratio	FM mode	–	2	–	
		standard, Europe and local weather band (WX)	–	1	–	

New In Car Entertainment (NICE) car radio

TEA6845H

SYMBOL	PARAMETER	CONDITIONS	MIN.	TYP.	MAX.	UNIT
Oscillator divider N2						
N2	oscillator divider ratio	AM mode LW and MW SW	– –	10 5	– –	
Synthesizer						
PROGRAMMABLE DIVIDER						
N _{prog}	programmable divider ratio		512	–	32767	
ΔN _{step}	programmable divider step size		–	1	–	
REFERENCE FREQUENCY DIVIDER						
N _{ref}	crystal oscillator divider ratio	f _{xtal} = 20.5 MHz f _{ref} = 100 kHz f _{ref} = 50 kHz f _{ref} = 25 kHz f _{ref} = 20 kHz f _{ref} = 10 kHz	– – – – –	205 410 820 1025 2050	– – – – –	
CHARGE PUMP: PIN CPOUT						
I _{sink(cp1)}	low charge pump 1 peak sink current	FM weather band mode; 0.4 V < V _{CPOUT} < 7.6 V	200	300	400	μA
I _{source(cp1)}	low charge pump 1 peak source current	FM weather band mode; 0.4 V < V _{CPOUT} < 7.6 V	–400	–300	–200	μA
I _{sink(cp1)h}	high charge pump 1 peak sink current	AM stereo mode; N2 = 10 (LW and MW); 0.4 V < V _{CPOUT} < 7.6 V	0.7	1	1.3	mA
I _{source(cp1)h}	high charge pump 1 peak source current	AM stereo mode; N2 = 10 (LW and MW); 0.4 V < V _{CPOUT} < 7.6 V	–1.3	–1	–0.7	mA
I _{sink(cp2)}	charge pump 2 peak sink current	FM standard mode; 0.3 V < V _{CPOUT} < 7.1 V	100	130	160	μA
I _{source(cp2)}	charge pump 2 peak source current	FM standard mode; 0.3 V < V _{CPOUT} < 7.1 V	–160	–130	–100	μA
I _{Z(cp1)} , I _{Z(cp2)}	charge pump 1 or 2 current in 3-state	0 < V _{CPOUT} < 8.5 V	–5	–	+5	nA
CHARGE PUMP: PIN V _{tune}						
I _{sink(cp3)}	charge pump 3 peak sink current	FM standard mode; 0.4 V < V _{tune} < 7.6 V	2.1	3	3.9	mA
I _{source(cp3)}	charge pump 3 peak source current	FM standard mode; 0.4 V < V _{tune} < 7.6 V	–3.9	–3	–2.1	mA
I _{Z(cp3)}	charge pump 3 current in 3-state	0 < V _{tune} < 8.5 V	–5	–	+5	nA

New In Car Entertainment (NICE) car radio

TEA6845H

SYMBOL	PARAMETER	CONDITIONS	MIN.	TYP.	MAX.	UNIT
Antenna Digital Auto Alignment (DAA)						
DAA INPUT: PIN DAAIN						
$I_{bias(cp)}$	charge pump buffer input bias current	FM mode; $0.4\text{ V} < V_{DAAIN} < 8.0\text{ V}$	-10	-	+10	nA
		AM mode; $0\text{ V} < V_{DAAIN} < 8.5\text{ V}$	-10	-	+10	nA
$V_{i(cp)}$	charge pump buffer input voltage		0	-	8.5	V
DAA OUTPUT: PIN DAAOUT; note 2						
$V_{o(AM)}$	DAA output voltage in AM mode		-	-	0.3	V
$V_{o(FM)}$	DAA output voltage in FM mode	$V_{DAAIN} = 4.0\text{ V};$ $V_{DAAATD} = 0.7\text{ V}$ minimum value	-	-	0.5	V
		bits DAA[6:0] set to logic 0	1.5	1.65	1.8	V
		value: data byte 3 = 10101011	3.8	4	4.2	V
		maximum value; bits DAA[6:0] set to logic 1	8	-	8.5	V
		$V_{DAAIN} = 3.0\text{ V};$ $V_{DAAATD} = 0.7\text{ V};$ bits DAA[6:0] set to logic 1	6.2	6.5	6.8	V
		$V_{DAAIN} = 2\text{ V}$ data byte 3 = 11010101	3	3.3	3.6	V
		data byte 3 = 10101010	1.8	2	2.2	V
$V_{o(n)}$	DAA output noise voltage	FM mode; $V_{DAAIN} = 4\text{ V};$ data byte 3: bit 6 = 1, bits 5 to 0 = 0; B = 300 Hz to 15 kHz	-	30	100	μV
$\Delta V_{o(T)}$	DAA output voltage variation with temperature	$T_{amb} = -40\text{ to }+85\text{ }^\circ\text{C};$ data byte 3 = 10101011; $V_{DAAATD} = 0.7\text{ V}$	-8	-	+8	mV
$\Delta V_{o(step)}$	DAA step accuracy	FM mode; $V_{DAAOUT} < 8.0\text{ V};$ $n = 0\text{ to }127$	$0.5V_{LSB}$	V_{LSB}	$1.5V_{LSB}$	mV
$I_{o(sink)}$	DAA output sink current	$0.2\text{ V} < V_{DAAOUT} < 8.25\text{ V}$	50	-	-	μA
$I_{o(source)}$	DAA output source current		-	-	-50	μA
t_{st}	DAA output settling time	$0.2\text{ V} < V_{DAAOUT} < 8.25\text{ V};$ $C_L = 270\text{ pF}$	-	-	30	μs
RR	ripple rejection	$f_{ripple} = 100\text{ Hz}; V_{DAA4} = 1\text{ mV}$	-	50	-	dB
C_L	DAA output load capacitance	$V_{DAAOUT} < 8.0\text{ V};$ FM mode	-	-	270	pF

New In Car Entertainment (NICE) car radio

TEA6845H

SYMBOL	PARAMETER	CONDITIONS	MIN.	TYP.	MAX.	UNIT
DAA TEMPERATURE COMPENSATION: PIN DAATD						
I_{source}	compensation diode source current	$0.2 \text{ V} < V_{\text{DAATD}} < 1.5 \text{ V}$	-50	-40	-30	μA
TC_{source}	temperature coefficient of compensation diode source current	$0.2 \text{ V} < V_{\text{DAATD}} < 1.5 \text{ V};$ $T_{\text{amb}} = -40 \text{ to } +85 \text{ }^\circ\text{C}$	-300	-	+300	$\frac{10^{-6}}{\text{K}}$
IF counter (FM IF or AM IF2 counter)						
N_{IF}	IF counter length for AM and FM		-	8	-	bit
$T_{\text{count(IF)}}$	IF counter period	data byte 4: bit 7 = 1	-	2	-	ms
		data byte 4: bit 7 = 0	-	20	-	ms
R_{precount}	FM IF counter prescaler ratio	data byte 4: bit 3 = 1	-	10	-	
		data byte 4: bit 3 = 0	-	100	-	
Reference frequency for car sound processor IC; note 3						
REFERENCE FREQUENCY DIVIDER						
N_{ref}	crystal oscillator divider ratio		-	272	-	
f_{ref}	reference frequency	$f_{\text{xtal}} = 20.5 \text{ MHz}$	-	75.368	-	kHz
VOLTAGE GENERATOR; PIN FREF						
$V_{\text{o(p-p)}}$	AC output voltage (peak-to-peak value)		60	100	170	mV
V_{O}	DC output voltage		3.2	3.4	3.9	V
R_{O}	output resistance		-	-	50	$\text{k}\Omega$
$R_{\text{L(min)}}$	minimum load resistance		1	-	-	$\text{M}\Omega$
AM signal channel						
AM RF AGC STAGE INPUTS: PINS AMMIX1IN1 AND AMMIX1IN2						
$V_{\text{i(p)}}$	RF input voltage for AGC start level (peak value)	data byte 5: bit 5 = 0, bit 6 = 0	-	150	-	mV
		data byte 5: bit 5 = 1, bit 6 = 0	-	275	-	mV
		data byte 5: bit 5 = 0, bit 6 = 1	-	400	-	mV
		data byte 5: bit 5 = 1, bit 6 = 1	-	525	-	mV
AM IF AGC STAGE INPUTS: PINS AMIF2IN AND AMIF2DEC						
$V_{\text{i(p)}}$	IF2 input voltage (peak value)	AGC start level	0.20	0.27	0.35	V
AM RF AGC CURRENT GENERATOR OUTPUT: PIN IAMAGC						
$I_{\text{sink(max)}}$	maximum AGC sink current	$V_{\text{AMMIX1IN1}} > 500 \text{ mV}$ (peak value)	-	15	-	mA
R_{O}	output resistance	$I_{\text{IAMAGC}} = 1 \mu\text{A}$	1	-	-	$\text{M}\Omega$
C_{O}	output capacitance		-	5	7	pF

New In Car Entertainment (NICE) car radio

TEA6845H

SYMBOL	PARAMETER	CONDITIONS	MIN.	TYP.	MAX.	UNIT
AM RF AGC PEAK DETECTOR: PIN T2AMAGC						
I_{att}	attack current AGC peak detector	data byte 5: bit 5 = 1, bit 6 = 1; AM mixer 1 input $V_i = 1$ V; $V_{T2AMAGC-GND} = 3$ V; $V_{AMIF2IN-AMIF2DEC} = 0$ V	–	–3.15	–	mA
I_{dec}	decay current AGC peak detector	data byte 5: bit 5 = 1, bit 6 = 1; AM mixer 1 input $V_i = 0$ V; $V_{T2AMAGC-AMMIX1IN2} = 0.25$ V; $V_{T2AMAGC-GND} = 3$ V; $V_{AMIF2IN-AMIF2DEC} = 0$ V	–	2.6	–	μ A
AM MIXER 1 (IF1 = 10.7 MHz)						
<i>Mixer inputs: pins AMMIX1IN1 and AMMIX1IN2</i>						
R_i	input resistance	note 4	50	70	100	k Ω
C_i	input capacitance	note 4	–	5	7	pF
V_i	DC input voltage		2.3	2.7	3.1	V
$V_{i(max)}$	maximum voltage on pin AMMIX1IN1	1 dB compression point of AM mixer 1 output (peak-to-peak)	500	–	–	mV
<i>Mixer outputs: pins MIX1OUT1 and MIX1OUT2</i>						
R_o	output resistance	note 5	100	–	–	k Ω
C_o	output capacitance	note 5	–	5	7	pF
$V_{o(max)(p-p)}$	maximum output voltage (peak-to-peak value)		12	15	–	V
I_{bias}	mixer bias current	AM mode	4.8	6	7.2	mA
Mixer						
$g_{m(conv)}$	conversion transconductance $\frac{I_{MIXOUT1}}{V_{FMMIXIN1} - V_{FMMIXIN2}}$		2.0	2.55	3.2	$\frac{mA}{V}$
$g_{m(conv)(T)}$	conversion transconductance variation with temperature $\frac{\Delta g_{m(conv)}}{g_{m(conv)} \times \Delta T}$		–	-9×10^{-4}	–	K $^{-1}$
IP3	3rd-order intermodulation	$R_L = 2.8$ k Ω (AC load between output pins)	135	138	–	dB μ V
IP2	2nd-order intermodulation	$R_L = 2.8$ k Ω (AC load between output pins)	–	170	–	dB μ V
$V_{i(n)(eq)}$	equivalent input noise voltage	band limited noise; $R_{gen} = 750$ Ω ; $R_L = 2.8$ k Ω (AC load between output pins)	–	5.8	–	$\frac{nV}{\sqrt{Hz}}$

New In Car Entertainment (NICE) car radio

TEA6845H

SYMBOL	PARAMETER	CONDITIONS	MIN.	TYP.	MAX.	UNIT
F	noise figure of AM mixer 1		–	4.5	7.1	dB
WEATHER BAND FLAG: PIN T1AMAGC						
$I_{L(max)}$	maximum load current		–5	–	+5	μA
$V_{o(max)}$	maximum output voltage for FM mode	measured with respect to pin RFGND	0	–	0.5	V
$V_{o(min)}$	minimum output voltage for WX mode	measured with respect to pin RFGND	5.1	6.0	6.9	V
AM MIXER 2 (IF2 = 450 kHz)						
<i>Mixer inputs: pins IFAMP1IN and IFAMP1DEC</i>						
R_i	input resistance	note 6	270	330	390	Ω
C_i	input capacitance	note 6	–	5	7	pF
V_I	DC input voltage		2.4	2.7	3	V
$V_{i(max)(p)}$	maximum input voltage (peak value)	1 dB compression point of AM mixer 2 output (peak-to-peak)	1.1	–	–	V
<i>Mixer outputs: pins AMMIX2OUT1 and AMMIX2OUT2</i>						
R_o	output resistance	note 7	100	–	–	k Ω
C_o	output capacitance	note 7	–	5	7	pF
$V_{o(max)(p-p)}$	maximum output voltage (peak-to-peak value)	$V_{DDA} = 8.5 \text{ V}$	12	15	–	V
I_{bias}	mixer bias current	AM mode	3.6	4.5	5.4	mA
<i>Mixer</i>						
$g_{m(conv)}$	conversion transconductance $\frac{I_{AMMIX2OUT1}}{V_{IFAMP1IN}}$		1.3	1.6	1.9	$\frac{\text{mA}}{\text{V}}$
$g_{m(conv)(T)}$	conversion transconductance variation with temperature $\frac{\Delta g_{m(conv)}}{g_{m(conv)} \times \Delta T}$		–	-9×10^{-4}	–	K^{-1}
IP3	3rd-order intermodulation	$R_L = 4 \text{ k}\Omega$ (AC load between output pins)	134	137	–	dB μV
IP2	2nd-order intermodulation	$R_L = 4 \text{ k}\Omega$ (AC load between output pins)	–	170	–	dB μV
$V_{i(n)(eq)}$	equivalent input noise voltage	$R_{gen} = 330 \text{ }\Omega$; $R_L = 4 \text{ k}\Omega$ (AC load between output pins)	–	15	22	$\frac{\text{nV}}{\sqrt{\text{Hz}}}$
F	noise figure of AM mixer 2		–	16	19.5	dB

New In Car Entertainment (NICE) car radio

TEA6845H

SYMBOL	PARAMETER	CONDITIONS	MIN.	TYP.	MAX.	UNIT
AM IF2 AGC STAGE: PINS AMIF2IN AND AMIF2DEC; note 8						
V_i	input voltage	for $\alpha = -10$ dB audio attenuation				
		AM soft mute on	–	75	120	μV
		AM soft mute off	–	6	10	μV
$V_{\text{AGC}(\text{start})}$	AGC start voltage	input carrier voltage	–	14	30	μV
$V_{\text{AGC}(\text{stop})}$	AGC stop voltage	maximum input peak voltage	1	–	–	V
$V_{\text{AGC}(\text{ctrl})}$	AGC control voltage	$V_i = 1$ mV	4.1	4.3	4.7	V
ΔAGC	AGC range	between start and stop of AGC; $m = 0.8$	–	89	–	dB
R_i	input resistance		1.8	2	2.2	$\text{k}\Omega$
C_i	input capacitance		–	–	5	pF
AM DETECTOR						
$V_{\text{sens}(\text{rms})}$	sensitivity voltage (RMS value)	$m = 0.3$; $f_{\text{mod}} = 400$ Hz; $B_{\text{AF}} = 2.5$ kHz; $R_{\text{gen}} = 2$ $\text{k}\Omega$; note 8				
		(S+N)/N = 26 dB	–	45	65	μV
		(S+N)/N = 46 dB	–	600	900	μV
(S+N)/N	maximum signal plus noise-to-noise ratio	$m = 0.3$; $f_{\text{mod}} = 400$ Hz; $B_{\text{AF}} = 2.5$ kHz; $R_{\text{gen}} = 2$ $\text{k}\Omega$	54	60	–	dB
THD	total harmonic distortion	$B_{\text{AF}} = 2.5$ kHz; $C_{\text{AGC}} = 22$ μF ; AM IF2 AGC input $V_i = 100$ μV to 500 mV (RMS)				
		$m = 0.8$; $f_{\text{mod}} = 400$ Hz	–	0.5	1	%
		$m = 0.9$; $f_{\text{mod}} = 400$ Hz	–	1	2	%
		$m = 0.8$; $f_{\text{mod}} = 100$ Hz	–	1.25	2.5	%
		$m = 0.9$; $f_{\text{mod}} = 100$ Hz	–	1.75	3.5	%
RR	ripple rejection	$V_{\text{DDA2}(\text{ripple})} = 100$ mV (RMS); $f_{\text{ripple}} = 100$ Hz	30	40	–	dB
t_{sw}	FM to AM switching time	$C_{\text{AGC}} = 22$ μF	–	1000	1500	ms
t_{settle}	AM AGC settling time	$C_{\text{AGC}} = 22$ μF				
		normal operation	–	–	1800	ms
		test mode	–	–	180	ms
<i>Output: pin AMAFIF2</i>						
$V_{\text{o}(\text{rms})}$	AM IF2 output voltage (RMS value)	AM stereo; $m = 0$				
		minimum at $V_i = 14$ μV	1.5	3	4.5	mV
		maximum at $V_i = 5.0$ mV	130	180	230	mV
		AM mono; $m = 0.3$; $f_{\text{mod}} = 400$ Hz; $V_i = 100$ μV to 500 mV (RMS)	240	290	340	mV
R_o	output resistance	AM stereo	–	–	500	Ω
		AM mono	–	–	500	Ω

New In Car Entertainment (NICE) car radio

TEA6845H

SYMBOL	PARAMETER	CONDITIONS	MIN.	TYP.	MAX.	UNIT
C_o	output capacitance	AM mono	–	5	7	pF
AM IF2 LEVEL DETECTOR OUTPUT: PIN V_{level} ; see Fig.3						
V_{level}	DC output voltage	$V_i = 10 \mu\text{V}$ to 1 V	0	–	7	V
		$V_i < 1 \mu\text{V}$; standard setting of level DAA and level slope	0.1	0.5	0.9	V
		$V_i = 1.4 \text{ mV}$; standard setting of level DAA	1.6	2.2	2.8	V
ΔV_{level}	step size for adjustment of level starting point	standard setting of level slope	30	40	50	mV
$V_{level(slope)}$	slope of level voltage	standard setting of level slope	650	800	950	$\frac{\text{mV}}{20 \text{ dB}}$
ΔV_{step}	step size for adjustment of level slope	$V_i = 1.4 \text{ mV}$	45	60	75	$\frac{\text{mV}}{20 \text{ dB}}$
B_{level}	bandwidth of level output voltage		200	300	–	kHz
R_o	output resistance		–	–	500	Ω
RR	ripple rejection	$V_{DDA1(ripple)} = 100 \text{ mV (RMS)}$; $f_{ripple} = 100 \text{ Hz}$	–	40	–	dB
AM NOISE BLANKER; see Fig.4						
<i>Threshold: pin AMNBHOLD</i>						
V_o	DC output voltage		4.3	4.6	5.1	V
t_{sup}	suppression time		6	7.5	10	μs
$f_{trigger}$	trigger sensitivity frequency	$V_{pulse} = 200 \text{ mV (peak)}$; $V_{level} < 1.8 \text{ V}$	–	1000	–	Hz
		$V_{pulse} = 200 \text{ mV (peak)}$; $V_{level} > 2.2 \text{ V}$	–	–	100	Hz
		$V_{pulse} = 20 \text{ mV (peak)}$; $V_{level} < 1.8 \text{ V}$	–	–	100	Hz
<i>Noise detector output: pin TRDSMUTE</i>						
$I_{sink(AGC)}$	AM noise blanker AGC sink current	$V_{TRDSMUTE} = 3 \text{ V}$	35	50	65	μA
V_{AGC}	AM noise blanker AGC voltage	AM mixer 1 input $V_i = 0 \text{ V}$	1.9	2.2	2.5	V
FM signal channel						
FM RF AGC						
<i>Inputs: pins FMMIXIN1 and FMMIXIN2; note 9</i>						
$V_{i(RF)(rms)}$	RF input voltage for start of wide-band AGC (RMS value)	data byte 5: bit 5 = 0, bit 6 = 0	–	4	–	mV
		data byte 5: bit 5 = 1, bit 6 = 0	–	8	–	mV
		data byte 5: bit 5 = 0, bit 6 = 1	–	12	–	mV
		data byte 5: bit 5 = 1, bit 6 = 1	–	16	–	mV

New In Car Entertainment (NICE) car radio

TEA6845H

SYMBOL	PARAMETER	CONDITIONS	MIN.	TYP.	MAX.	UNIT
<i>AGC peak detector output: pin T1FMAGC</i>						
I_{ch}	charge current		-350	-600	-850	μA
I_{dch}	discharge current		15	25	35	μA
<i>PIN diode drive output: pin IFMAGC</i>						
I_{drive}	drive current	$V_o = 0.5$ to 4.0 V	8	11.5	15	mA
<i>Level voltage output: pin V_{level}</i>						
V_{th}	threshold voltage for narrow-band AGC	data byte 5: bit 7 = 1; standard setting of level DAA	500	950	1400	mV
FM RF MIXER						
<i>Reference voltage: pin $V_{ref(FMMIX)}$</i>						
V_{ref}	reference voltage	FM mode	6.5	7.1	7.9	V
		AM mode	2.7	3.1	3.4	V
<i>Inputs: pins FMMIXIN1 and FMMIXIN2; note 9</i>						
$V_{i(RF)(max)}$	maximum RF input voltage	1 dB compression point of FM mixer output voltage (peak-to-peak value)	70	100	-	mV
$V_{i(n)(eq)}$	equivalent input noise voltage	$R_{gen} = 600 \Omega$; $R_L = 2.8 \text{ k}\Omega$	-	2.6	3.1	$\frac{\text{nV}}{\sqrt{\text{Hz}}}$
R_i	input resistance		-	1.4	-	$\text{k}\Omega$
C_i	input capacitance		-	5	7	pF
<i>Outputs: pins MIX1OUT1 and MIX1OUT2; note 5</i>						
R_o	output resistance		100	-	-	$\text{k}\Omega$
C_o	output capacitance		-	5	7	pF
I_{bias}	mixer bias current	FM mode	4.8	6	7.2	mA
$V_{o(max)(p-p)}$	maximum output voltage (peak-to-peak value)		3	-	-	V
FM mixer						
$g_{m(conv)}$	conversion transconductance		8.5	12.5	18	$\frac{\text{mA}}{\text{V}}$
$g_{m(conv)(T)}$	conversion transconductance variation with temperature		-	-1×10^{-3}	-	K^{-1}
F	noise figure		-	3	4.6	dB
IP3	3rd-order intermodulation		116	119	-	$\text{dB}\mu\text{V}$
IRR	image rejection ratio		25	30	-	dB
IF AMPLIFIER 1						
G	gain	$R_L = 330 \Omega$; $V_i = 1 \text{ mV}$; note 10	13.5	15.5	17.5	dB
F	noise figure		-	10	13	dB
IP3	3rd-order intermodulation		117	120	-	$\text{dB}\mu\text{V}$

New In Car Entertainment (NICE) car radio

TEA6845H

SYMBOL	PARAMETER	CONDITIONS	MIN.	TYP.	MAX.	UNIT
<i>Inputs: pins IFAMP1IN and IFAMP1DEC; note 10</i>						
$V_{i(max)(p)}$	maximum input voltage (peak value)	1 dB compression point of IF amplifier 1 output voltage (peak value)	200	–	–	mV
$V_{i(n)(eq)}$	equivalent input noise voltage	$R_{gen} = 330 \Omega$; $R_L = 330 \Omega$	–	8	10	$\frac{nV}{\sqrt{Hz}}$
R_i	input resistance		270	330	390	Ω
C_i	input capacitance		–	5	7	pF
<i>Output: pin IFAMP1OUT</i>						
$V_{o(max)(p)}$	maximum output voltage (peak value)		1.2	1.5	–	V
R_o	output resistance		270	330	390	Ω
C_o	output capacitance		–	5	7	pF
IF AMPLIFIER 2						
G	gain	$R_L = 330 \Omega$; $V_i = 1 \text{ mV}$; note 11	6.5	8.5	10.5	dB
F	noise figure		–	13	15	dB
IP3	3rd-order intermodulation		127	130	–	dB μ V
<i>Inputs: pins IFAMP2IN and IFAMP2DEC; note 11</i>						
$V_{i(max)(p)}$	maximum input voltage (peak value)	1 dB compression point of IF amplifier 2 output voltage (peak value)	500	–	–	mV
$V_{i(n)(eq)}$	equivalent input noise voltage	$R_{gen} = 330 \Omega$; $R_L = 330 \Omega$	–	10	13	$\frac{nV}{\sqrt{Hz}}$
R_i	input resistance		270	330	390	Ω
C_i	input capacitance		–	5	7	pF
<i>Output: pin IFAMP2OUT</i>						
$V_{o(max)(p)}$	maximum output voltage (peak value)		1.2	1.5	–	V
R_o	output resistance		270	330	390	Ω
C_o	output capacitance		–	5	7	pF
FM demodulator and level detector; see Figs 5 and 6						
FM LIMITER						
<i>Inputs: pins FMLIMIN and FMLIMDEC; note 12</i>						
G	gain	$R_{gen} = 50 \Omega$	74	80	–	dB
R_i	input resistance		270	330	390	k Ω
C_i	input capacitance		–	5	7	pF
<i>Outputs: pins QDET1 and QDET2</i>						
$V_{o(p-p)}$	output voltage (peak-to-peak value)	measured between output pins	500	700	–	mV

New In Car Entertainment (NICE) car radio

TEA6845H

SYMBOL	PARAMETER	CONDITIONS	MIN.	TYP.	MAX.	UNIT
FM DEMODULATOR						
<i>Limiter decoupling: pin FMLIMDEC</i>						
R_L	load resistance		20	–	–	$k\Omega$
C_L	load capacitance		–	–	50	μF
<i>FM limiter inputs: pins FMLIMIN and FMLIMDEC; note 12</i>						
$V_{start(lim)(rms)}$	start of limiting of MPX output voltage (RMS value)	$\alpha_{AF} = -3$ dB	–	10	15	μV
$V_{o(sens)(rms)}$	sensitivity for MPX output voltage (RMS value)	$\Delta f = 22.5$ kHz; $f_{mod} = 1$ kHz; de-emphasis = 75 μs $(S+N)/N = 26$ dB $(S+N)/N = 46$ dB	– –	10 50	15 75	μV μV
<i>RDS MPX output: pin RDSMPX</i>						
$V_{o(rms)}$	RDS MPX output voltage (RMS value)	$\Delta f = 22.5$ kHz; $f_{mod} = 57$ kHz; $V_i = 20$ μV to 1 V; note 12	180	230	280	mV
$I_{o(max)}$	maximum RDS MPX output current		–	–	100	μA
R_o	output resistance		–	–	500	Ω
B	bandwidth RDS MPX output	$C_L = 0$; $R_L > 20$ $k\Omega$	200	300	–	kHz
PSRR	power supply ripple rejection	$f_{ripple} = 100$ Hz to 20 kHz	–	40	–	dB
<i>FM MPX output: pin FMMPX; note 12</i>						
$V_{o(rms)}$	MPX output voltage (RMS value)	$\Delta f = 22.5$ kHz; $f_{mod} = 1$ kHz; de-emphasis = 75 μs ; $V_i = 20$ μV to 1 V	180	230	280	mV
α_{AM}	AM suppression of MPX output	$\Delta f = 22.5$ kHz; $f_{mod} = 1$ kHz; $m = 0.3$; de-emphasis = 75 μs $V_i = 500$ μV to 300 mV $V_i = 20$ to 500 μV $V_i = 300$ mV to 1 V	50 – –	60 40 40	– – –	dB dB dB
$I_{o(max)}$	maximum MPX output current		–	–	100	μA
(S+N)/N	maximum signal plus noise-to-noise ratio of MPX output voltage	$\Delta f = 22.5$ kHz; $f_{mod} = 1$ kHz; de-emphasis = 75 μs ; $V_i = 10$ mV	67	70	–	dB
THD	total harmonic distortion of MPX output voltage	$\Delta f = 75$ kHz; $f_{mod} = 1$ kHz; de-emphasis = 75 μs ; $V_i = 200$ μV to 800 mV	–	0.35	0.7	%
B	bandwidth MPX output	$C_L = 0$; $R_L > 20$ $k\Omega$	200	–	–	kHz
PSRR	power supply ripple rejection	$f_{ripple} = 100$ Hz to 20 kHz	–	40	–	dB
$R_{L(min)}$	minimum load resistance		20	–	–	$k\Omega$

New In Car Entertainment (NICE) car radio

TEA6845H

SYMBOL	PARAMETER	CONDITIONS	MIN.	TYP.	MAX.	UNIT
$R_{o(max)}$	maximum output resistance		–	–	500	Ω
$C_{L(max)}$	maximum load capacitance		–	–	50	pF
MPX MUTE						
α_{mute}	muting depth	during RDS update	60	80	–	dB
t_{att}	attack time MPX mute	$C_{TRDSMUTE} = 10 \text{ nF}$	0.75	1	1.25	ms
t_{decay}	decay time MPX mute	$C_{TRDSMUTE} = 10 \text{ nF}$	0.75	1	1.25	ms
<i>RDS update: pin TRDSMUTE</i>						
I_{dch}	discharge current	$V_o = 3 \text{ V}$; audio output muted	24	32	38	μA
I_{ch}	charge current	$V_o = 3 \text{ V}$; audio output not muted	–24	–32	–38	μA
DEMODULATOR AFC						
G_{AFC}	AFC gain	$\Delta f = 100 \text{ kHz}$	28	32	–	dB
<i>RDS MPX output: pin RDSMPX; note 12</i>						
$V_{offset(DC)}$	residual DC offset voltage	$L_{demod} = \text{typical value}$				
		$V_i = 10 \text{ to } 80 \mu\text{V}$	–	0.1	1	V
		$V_i = 80 \mu\text{V to } 800 \text{ mV}$	–	10	30	mV
		$L_{demod} = \pm 6\%$				
		$V_i = 10 \text{ to } 80 \mu\text{V}$	–	0.240	1	V
		$V_i = 80 \mu\text{V to } 800 \text{ mV}$	–	25	500	mV
FM IF LEVEL DETECTOR OUTPUT: PIN V_{level}; note 12						
V_{level}	DC output voltage	$V_i = 10 \mu\text{V to } 1 \text{ V}$	0	–	7	V
		$V_i < 1 \mu\text{V}$; standard setting of level DAA	0.2	0.6	1.1	V
		$V_i = 1 \text{ mV}$; standard setting of level DAA	1.4	1.9	2.5	V
ΔV_{level}	level starting point for adjustment of step size	standard setting of level slope	30	40	50	mV
$V_{level(slope)}$	slope of level voltage	standard setting of level slope	650	800	950	$\frac{\text{mV}}{20 \text{ dB}}$
ΔV_{step}	level slope adjustment of step size	$V_i = 1 \text{ mV}$	45	50	75	$\frac{\text{mV}}{20 \text{ dB}}$
B_{level}	bandwidth of level output voltage	$V_i = 10 \text{ mV}$; $f_{mod} = 22.5 \text{ kHz}$; standard setting of DAA	200	300	–	kHz
R_o	output resistance		–	–	500	Ω
RR	ripple rejection	$V_{DDA1(ripple)} = 100 \text{ mV (RMS)}$; $f_{ripple} = 100 \text{ Hz}$	–	40	–	dB

New In Car Entertainment (NICE) car radio

TEA6845H

SYMBOL	PARAMETER	CONDITIONS	MIN.	TYP.	MAX.	UNIT
RDS update						
<i>Output: pin AFHOLD</i>						
$I_{\text{sink(max)}}$	maximum sink current	after first bus transmission with AF = 1 (start of RDS update); $V_o = 0.5 \text{ V}$	1.0	1.2	1.4	mA
<i>Output: pin AFSAMPLE</i>						
$I_{\text{sink(max)}}$	maximum sink current	no RDS update in progress; $V_o = 0.5 \text{ V}$	1.0	1.2	1.4	mA
Test mode; note 3						
<i>Temperature compensation diode: pin DAATD</i>						
$V_{i(\text{ext})}$	external input voltage to clock state machine	$V_{\text{DAATD(L)}} = 2.5 \text{ V}$; $V_{\text{DAATD(H)}} = 3.5 \text{ V}$	2.5	–	3.5	V
<i>Clock input: pin SCL</i>						
$V_{i(\text{ext})}$	external input voltage to clock DAA	$V_{\text{SCL(L)}} = 0 \text{ V}$; $V_{\text{SCL(H)}} = 5 \text{ V}$	0	–	5	V
<i>Time constant output: pin T1AMAGC</i>						
V_{pulse}	enabling voltage of load PLL signal	pin FREF in test mode	5.1	6	6.9	V

Notes

- Measured between pins XTAL1 and XTAL2.
- DAA conversion gain formula: $V_{\text{DAAOUT}} = \left[2 \times \left(0.75 \times \frac{n}{128} + 0.25 \right) \times (V_{\text{DAAIN}} + V_{\text{DAATD}}) \right] - V_{\text{DAATD}}$
where $n = 0$ to 127 .
- Reference frequency pin FREF:
 - $R_{\text{ext}} = 68 \text{ k}\Omega$ connected to ground activates the 2nd I²C-bus address
 - $R_{\text{ext}} = 100 \text{ k}\Omega$ connected to V_{DDA1} sets the IC into test mode.
- Input parameters of AM mixer 1 measured between pins AMMIX1IN1 and AMMIX1IN2.
- Output parameters of FM mixer and AM mixer 1 measured between pins MIX1OUT1 and MIX1OUT2.
- Input parameters of AM mixer 2 measured between pins IFAMP1IN and IFAMP1DEC.
- Output parameters of AM mixer 2 measured between pins AMMIX2OUT1 and AMMIX2OUT2.
- Input parameters of AM IF2 measured between pins AMIF2IN and AMIF2DEC.
- Input parameters of FM mixer measured between pins FMMIXIN1 and FMMIXIN2.
- Input parameters of IF amplifier 1 measured between pins IFAMP1IN and IFAMP1DEC.
- Input parameters of IF amplifier 2 measured between pins IFAMP2IN and IFAMP2DEC.
- Input parameters of FM limiter measured between pins FMLIMIN and FMLIMDEC.

New In Car Entertainment (NICE) car radio

TEA6845H

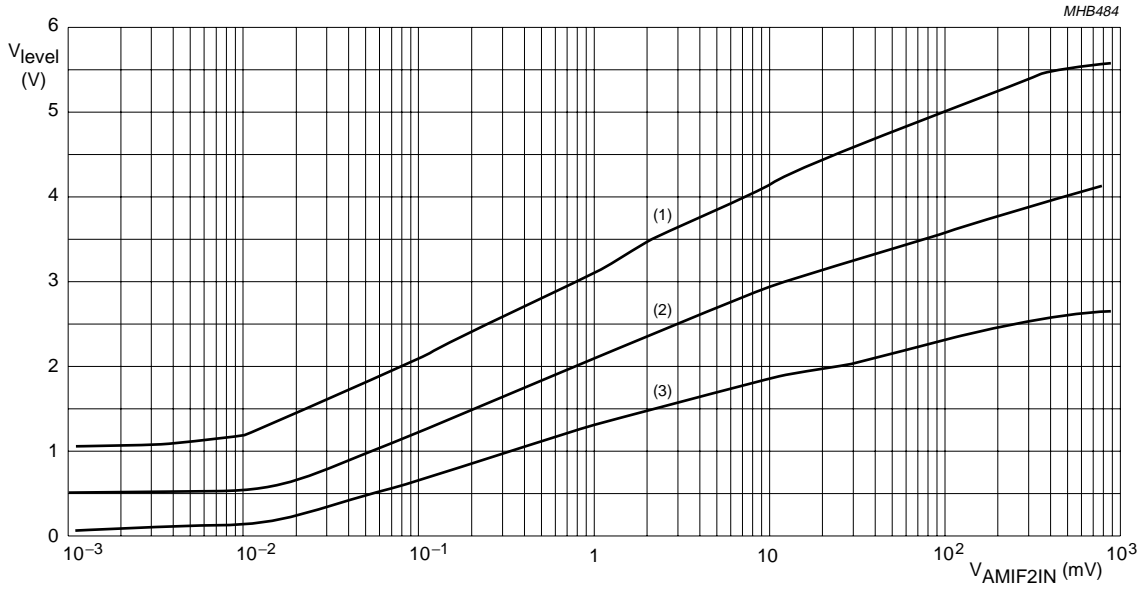

- (1) Level DAA setting byte 6 = FFH.
- (2) Level DAA setting byte 6 = 84H (standard setting).
- (3) Level DAA setting byte 6 = 00H.

Fig.3 AM level output voltage (DAA) as a function of AM level circuit input voltage.

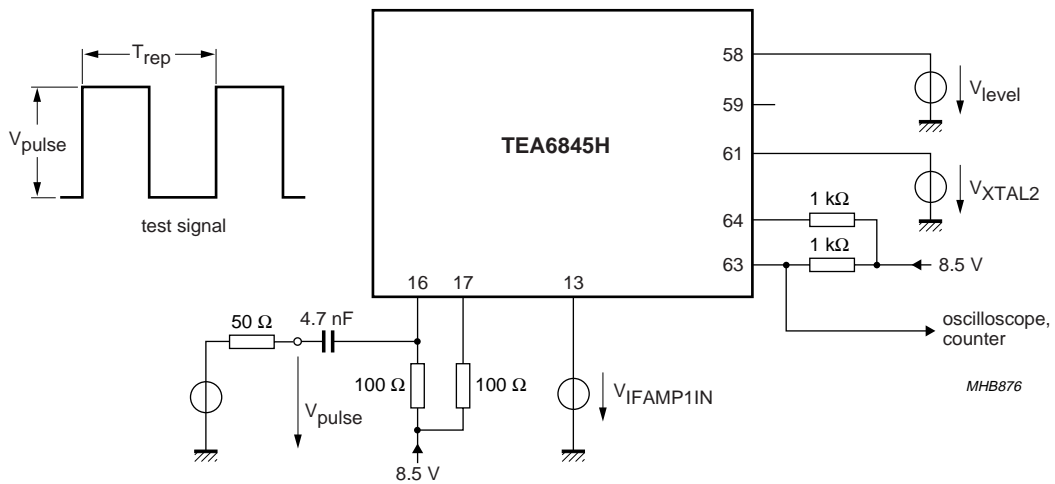

Test signal: $T_{rep} = 2 \text{ ms}$, $t_r < 50 \text{ ns}$, $t_f < 50 \text{ ns}$, and duty factor 50%.

$V_{IFAMP1IN} = 4 \text{ V}$.
 $V_{XTAL2} = 3 \text{ V}$.

Fig.4 Test circuit for AM noise blanker.

New In Car Entertainment (NICE) car radio

TEA6845H

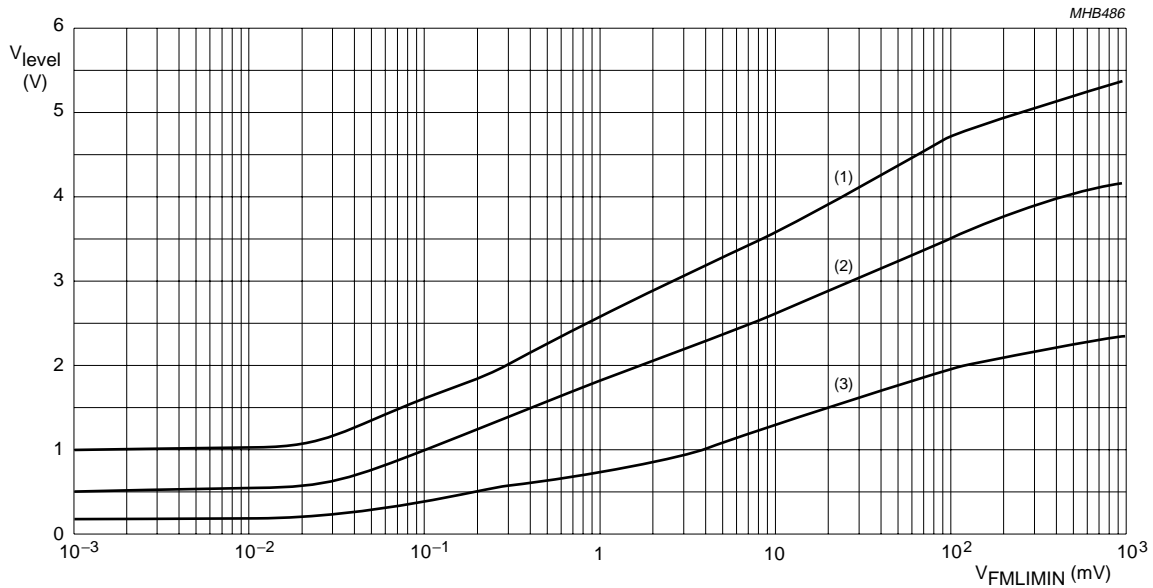

- (1) Level DAA setting byte 6 = FFH.
- (2) Level DAA setting byte 6 = 84H (standard setting).
- (3) Level DAA setting byte 6 = 00H.

Fig.5 FM level output voltage (DAA) as a function of FM limiter and level circuit input voltage.

New In Car Entertainment (NICE) car radio

TEA6845H

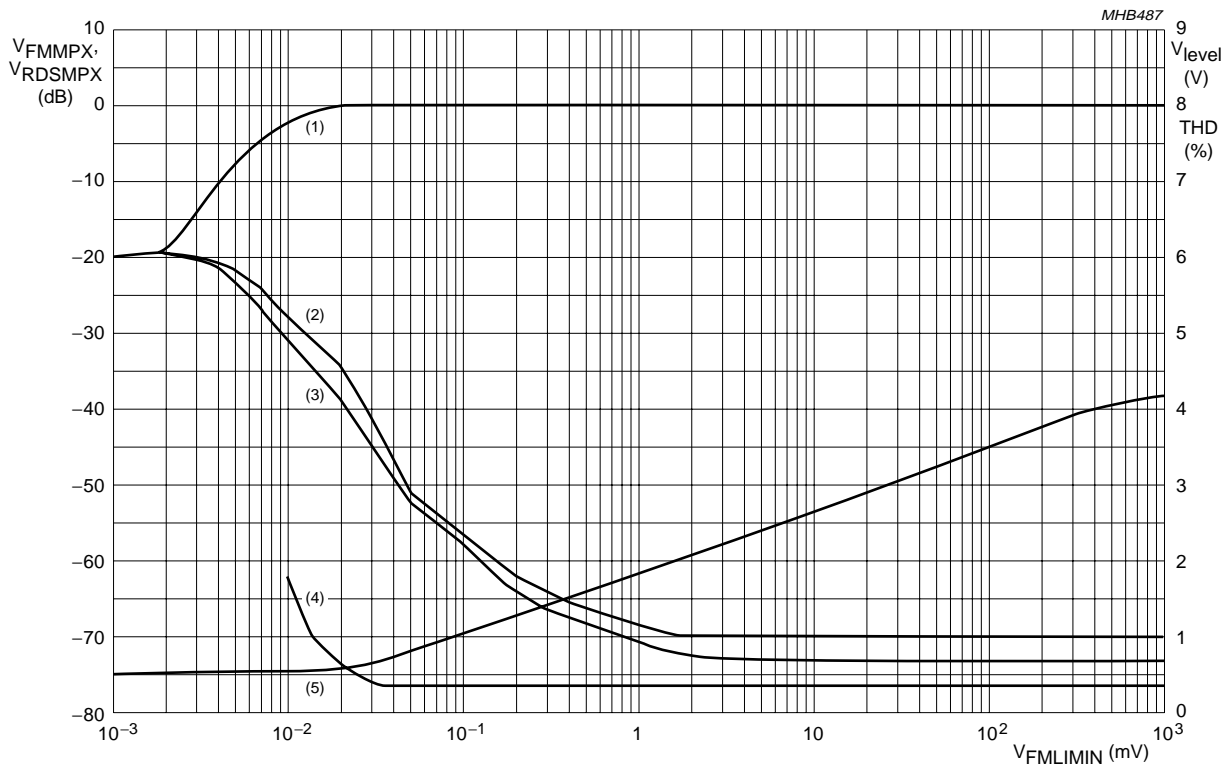

- (1) Output voltage for FMMPX and RDSMPX: $f_{IF} = 10.7$ MHz; $\Delta f = 22.5$ kHz; $f_{mod} = 1$ kHz.
- (2) Noise: unweighted B = 250 Hz to 15 kHz with de-emphasis 50 μ s for FMMPX.
- (3) Noise: unweighted B = 250 Hz to 15 kHz with de-emphasis 50 μ s for RDSMPX.
- (4) THD for FMMPX and RDSMPX.
- (5) Level for standard setting of level DAA, byte 6 = 84H.

Fig.6 (S+N)/N, THD and level output voltage for FM mode as a function of FM demodulator input voltage.

New In Car Entertainment (NICE) car radio

TEA6845H

12 I²C-BUS PROTOCOL

12.1 I²C-bus specification

Information about the I²C-bus can be found in the brochure "The I²C-bus and how to use it" (order number 9398 393 40011).

The standard I²C-bus specification is expanded by the following definitions.

IC addresses:

- 1st IC address C2: 1100001
- 2nd IC address C0: 1100000.

Structure of the I²C-bus logic: slave transceiver with auto increment.

Subaddresses are not used.

Exception to the standard I²C-bus specification:

- The data hold time $t_{HD,DAT}$ must be at least 1 μ s.

12.1.1 TEST MODE

Connecting pin FREF to V_{DDA1} via a 100 k Ω resistor or feeding 50 μ A into that pin switches the IC into the test mode.

During test mode the digital-to-analog converters of the level and antenna DAA functions can be sequenced by the I²C-bus SCL line.

During test mode either the TEA688x or TEF689x reference frequency, the PLL reference frequency divider or the programmable divider output can be switched to pin FREF.

12.1.2 DATA TRANSFER

Data sequence: address, byte 1, byte 2, byte 3, byte 4, byte 5, and byte 6. The data transfer has to be in this

order. The LSB = 0 indicates a WRITE operation to the TEA6845H.

Bit 7 of each byte is considered the MSB and has to be transferred as the first bit of the byte.

The data becomes valid at the output of the internal latches with the acknowledge of each byte. A STOP condition after any byte can shorten transmission times.

When writing to the transceiver by using the STOP condition before completion of the whole transfer:

- The remaining bytes will contain the old information
- If the transfer of a byte is not completed, this byte is lost and the previous information is available.

In byte 5, 4 bits are reserved for test mode purposes. Those can only be used when the test mode is activated by the select pin FREF.

12.1.3 I²C-bus PULL-UP RESISTORS

When the IC is used together with the TEA688x or TEF689x and both SCL and SDA lines are connected via the I²C-bus to the TEA688x or TEF689x, the pull-up resistors of the tuner IC should be connected to the digital supply voltage of the TEA688x or TEF689x. Otherwise an I²C-bus pull-down can occur switching off the tuner IC supply when the I²C-bus buffer interface of the TEA688x or TEF689x is enabled for data transfer to the tuner IC.

12.1.4 FREQUENCY SETTING

For new frequency setting, in both AM and FM mode, the programmable divider is enabled by setting bit MUTE = 1. To select an FM frequency, two I²C-bus transmissions are necessary:

- First: bit MUTE = 1
- Second: bit MUTE = 0.

New In Car Entertainment (NICE) car radio

TEA6845H

12.2 I²C-bus protocol

12.2.1 DATA TRANSFER MODE AND IC ADDRESS

Table 1 Write mode

S ⁽¹⁾	address (write)	A ⁽²⁾	data byte(s)	A ⁽²⁾	P ⁽³⁾
------------------	-----------------	------------------	--------------	------------------	------------------

Notes

1. S = START condition.
2. A = acknowledge.
3. P = STOP condition.

Table 2 Read mode

S ⁽¹⁾	address (read)	A ⁽²⁾	data byte 1
------------------	----------------	------------------	-------------

Notes

1. S = START condition.
2. A = acknowledge.

Table 3 IC address byte

IC ADDRESS						MODE
1	1	0	0	0	0	0/1 ⁽¹⁾
						R/W ⁽²⁾

Notes

1. Defined by address pin FREF:
 - a) 1 = 1st IC address
 - b) 0 = 2nd IC address.
2. Read or write mode:
 - a) 0 = write operation to TEA6845H
 - b) 1 = read operation from TEA6845H.

12.2.2 WRITE MODE: DATA BYTE 1

Table 4 Format of data byte 1

BIT 7	BIT 6	BIT 5	BIT 4	BIT 3	BIT 2	BIT 1	BIT 0
AF	PCA6	PCA5	PCA4	PCA3	PCA2	PCA1	PCA0

Table 5 Description of data byte 1 bits

BIT	SYMBOL	DESCRIPTION
7	AF	Alternative frequency. If AF = 0, then normal operation. If AF = 1, then AF (RDS) update mode.
6 to 0	PCA[6:0]	Setting of programmable counter of synthesizer PLL. Upper byte of PLL divider word.

New In Car Entertainment (NICE) car radio

TEA6845H

12.2.3 WRITE MODE: DATA BYTE 2

Table 6 Format of data byte 2

BIT 7	BIT 6	BIT 5	BIT 4	BIT 3	BIT 2	BIT 1	BIT 0
PCB7	PCB6	PCB5	PCB4	PCB3	PCB2	PCB1	PCB0

Table 7 Description of data byte 2 bits

BIT	SYMBOL	DESCRIPTION
7 to 0	PCB[7:0]	Setting of programmable counter of synthesizer PLL. Lower byte of PLL divider word.

12.2.4 WRITE MODE: DATA BYTE 3

Table 8 Format of data byte 3

BIT 7	BIT 6	BIT 5	BIT 4	BIT 3	BIT 2	BIT 1	BIT 0
MUTE	DAA6	DAA5	DAA4	DAA3	DAA2	DAA1	DAA0

Table 9 Description of data byte 3 bits

BIT	SYMBOL	DESCRIPTION
7	MUTE	FM audio mute. If MUTE = 0, then FM audio not muted. If MUTE = 1, then FM audio muted; writing to programmable divider enabled.
6 to 0	DAA[6:0]	Setting of antenna digital auto alignment.

12.2.5 WRITE MODE: DATA BYTE 4

Table 10 Format of data byte 4

BIT 7	BIT 6	BIT 5	BIT 4	BIT 3	BIT 2	BIT 1	BIT 0
IFMT	RFS2	RFS1	RFS0	IFPR	BND1	BND0	AMFM

Table 11 Description of data byte 4 bits

BIT	SYMBOL	DESCRIPTION
7	IFMT	IF measuring time. If IFMT = 0, then IF measuring time is 20 ms. If IFMT = 1, then IF measuring time is 2 ms.
6 to 4	RFS[2:0]	Reference frequency for synthesizer. These 3 bits determine the reference frequency, see Table 12.
3	IFPR	IF counter prescaler ratio. If IFPR = 0, then IF prescaler ratio is 100. If IFPR = 1, then IF prescaler ratio is 10.
2 and 1	BND[1:0]	Band switch. These 2 bits select in FM mode band and local or distant, see Table 13; in AM mode band and AM stereo, see Table 14.
0	AMFM	AM or FM switch. If AMFM = 0, then FM mode. If AMFM = 1, then AM mode

New In Car Entertainment (NICE) car radio

TEA6845H

Table 12 Reference frequency setting

RFS2	RFS1	RFS0	f _{ref} (kHz)
0	0	0	100
1	0	0	50
0	1	0	25
1	1	0	20
0	0	1	10
1	0	1	10
0	1	1	10
1	1	1	10

Table 13 FM mode

BND1	BND0	SELECTION
0	0	FM standard: dead zone high current charge pump active, FM AGC defined by RF level and threshold level setting by I ² C-bus
0	1	FM local: dead zone high current charge pump active, FM AGC source current set to maximum
1	0	FM East Europe: dead zone high current charge pump switched off, current of low current charge pump set to 1 mA
1	1	FM weather band: N1 divider set to 1 and I and Q phase shift network switched on, WX flag signal activated

Table 14 AM mode; note 1

BND1	BND0	SELECTION
0	0	AM mono; N2 divider set to 5 (SW)
0	1	AM stereo; N2 divider set to 5 (SW)
1	0	AM mono; N2 divider set to 10 (LW, MW)
1	1	AM stereo; N2 divider set to 10 (LW, MW)

Note

1. In AM mode dead zone high current charge pump switched off, current of low current charge pump set to 1 mA.

New In Car Entertainment (NICE) car radio

TEA6845H

12.2.6 WRITE MODE: DATA BYTE 5

Table 15 Format of data byte 5

BIT 7	BIT 6	BIT 5	BIT 4	BIT 3	BIT 2	BIT 1	BIT 0
KAGC	WBA1	WBA0	AMSM	TMS3	TMS2	TMS1	TMS0

Table 16 Description of data byte 5 bits

BIT	SYMBOL	DESCRIPTION
7	KAGC	Keyed FM AGC. If KAGC = 0, then keyed FM AGC is off. If KAGC = 1, then keyed FM AGC is on.
6 and 5	WBA[1:0]	Wide band AGC. These 2 bits set the start value of wide band AGC. For AM, see Table 17 and for FM, see Table 18.
4	AMSM	AM soft mute. If AMSM = 0, then AM soft mute is off. If AMSM = 1, then AM soft mute is on.
3	TMS3	In test mode charge pump 3-state. If TMS3 = 0, then 3-state off. If TMS3 = 1, then 3-state on.
2	TMS2	In test mode external clock for level and antenna DAA. If TMS2 = 0, then external clock disabled. If TMS2 = 1, then external clock enabled.
1 and 0	TMS[1:0]	In test mode setting of pin FREF. These 2 bits define the function of pin FREF, see Table 19.

Table 17 Setting of wide band AGC for AM

WBA1	WBA0	AM MIXER 1 INPUT VOLTAGE (PEAK VALUE) (mV)
0	0	150
0	1	275
1	0	400
1	1	525

Table 18 Setting of wide band AGC for FM

WBA1	WBA0	FM RF MIXER INPUT VOLTAGE (RMS VALUE) (mV)
1	1	4
1	0	8
0	1	12
0	0	16

Table 19 Setting function of pin FREF in test mode

TMS1	TMS0	OUTPUT AT PIN FREF
0	0	reference frequency of TEA688x or TEF689x
0	1	tuner oscillator frequency divided by division ratio of programmable divider
1	0	PLL synthesizer reference frequency
1	1	not used (no output)

New In Car Entertainment (NICE) car radio

TEA6845H

12.2.7 WRITE MODE: DATA BYTE 6

Table 20 Format of data byte 6

BIT 7	BIT 6	BIT 5	BIT 4	BIT 3	BIT 2	BIT 1	BIT 0
LST4	LST3	LST2	LST1	LST0	LSL2	LSL1	LSL0

Table 21 Description of data byte 6 bits

BIT	SYMBOL	DESCRIPTION
7 to 3	LST[4:0]	Setting of level DAA starting point. These 5 bits determine the offset of the level detector output voltage.
2 to 0	LSL[2:0]	Setting of level DAA slope. These 3 bits determine the steepness of the level detector output voltage.

Table 22 Standard setting of data byte 6 bits

SETTING OF LEVEL DAA STARTING POINT					SETTING OF LEVEL DAA SLOPE		
LST4	LST3	LST2	LST1	LST0	LSL2	LSL1	LSL0
1	0	0	0	0	1	0	0

12.2.8 READ MODE: DATA BYTE 1

Table 23 Format of 1st data byte

BIT 7	BIT 6	BIT 5	BIT 4	BIT 3	BIT 2	BIT 1	BIT 0
IFC7	IFC6	IFC5	IFC4	IFC3	IFC2	IFC1	IFC0

Table 24 Description of data byte 1 bits

BIT	SYMBOL	DESCRIPTION
7 to 0	IFC[7:0]	IF counter result. These bits contain the last eight bits of the IF counter result.

New In Car Entertainment (NICE) car radio

TEA6845H

13 TEST AND APPLICATION INFORMATION

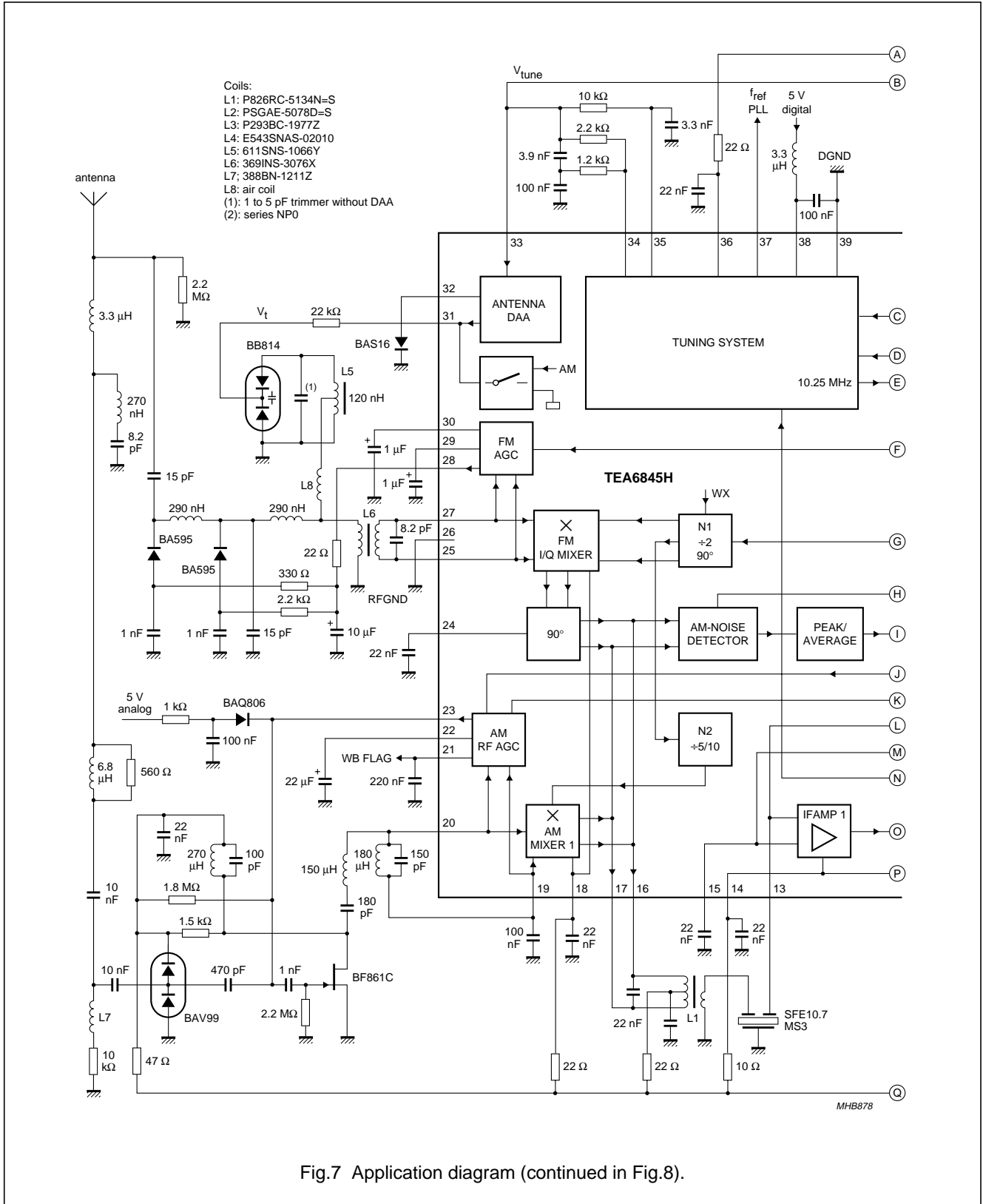

New In Car Entertainment (NICE) car radio

TEA6845H

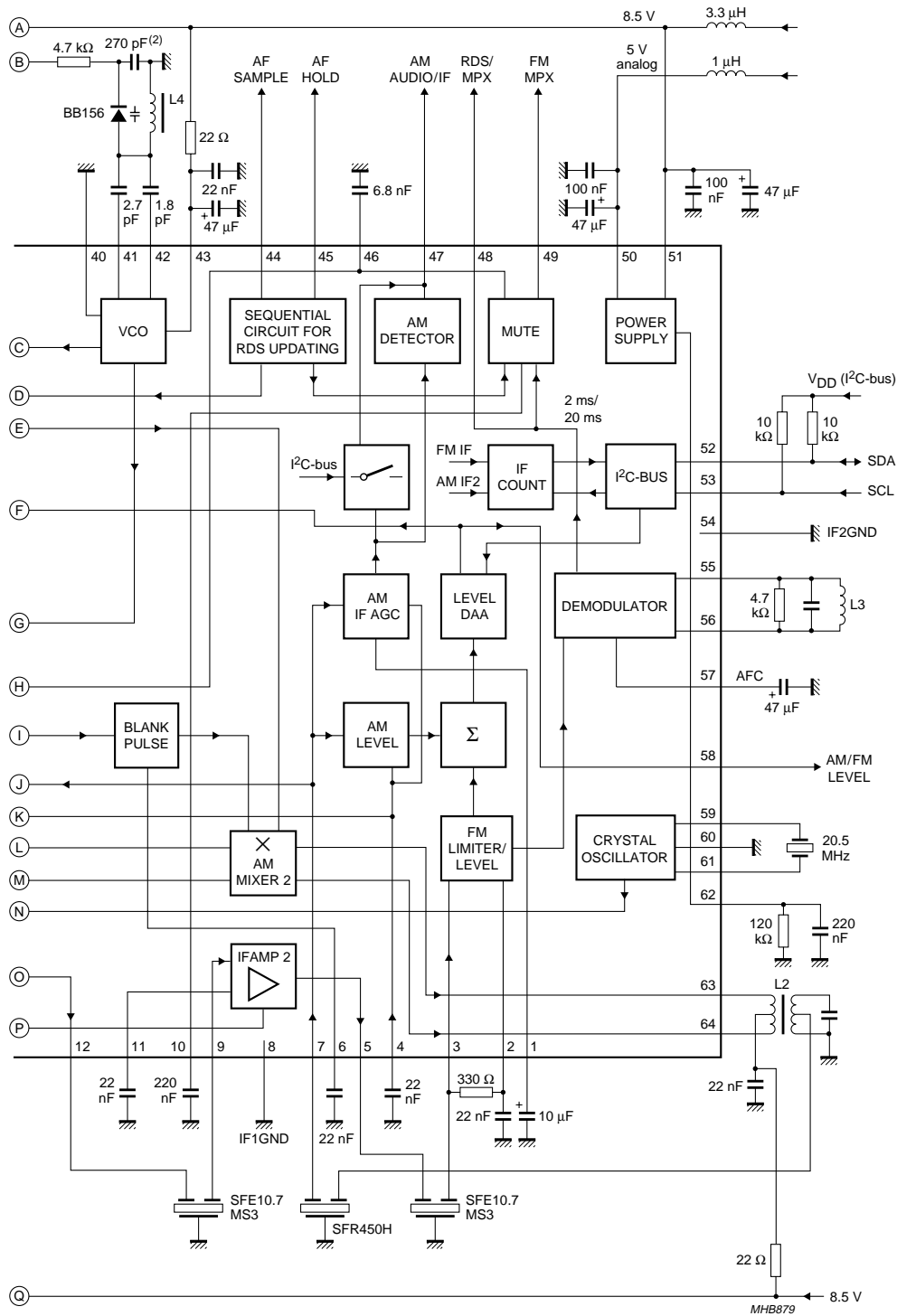
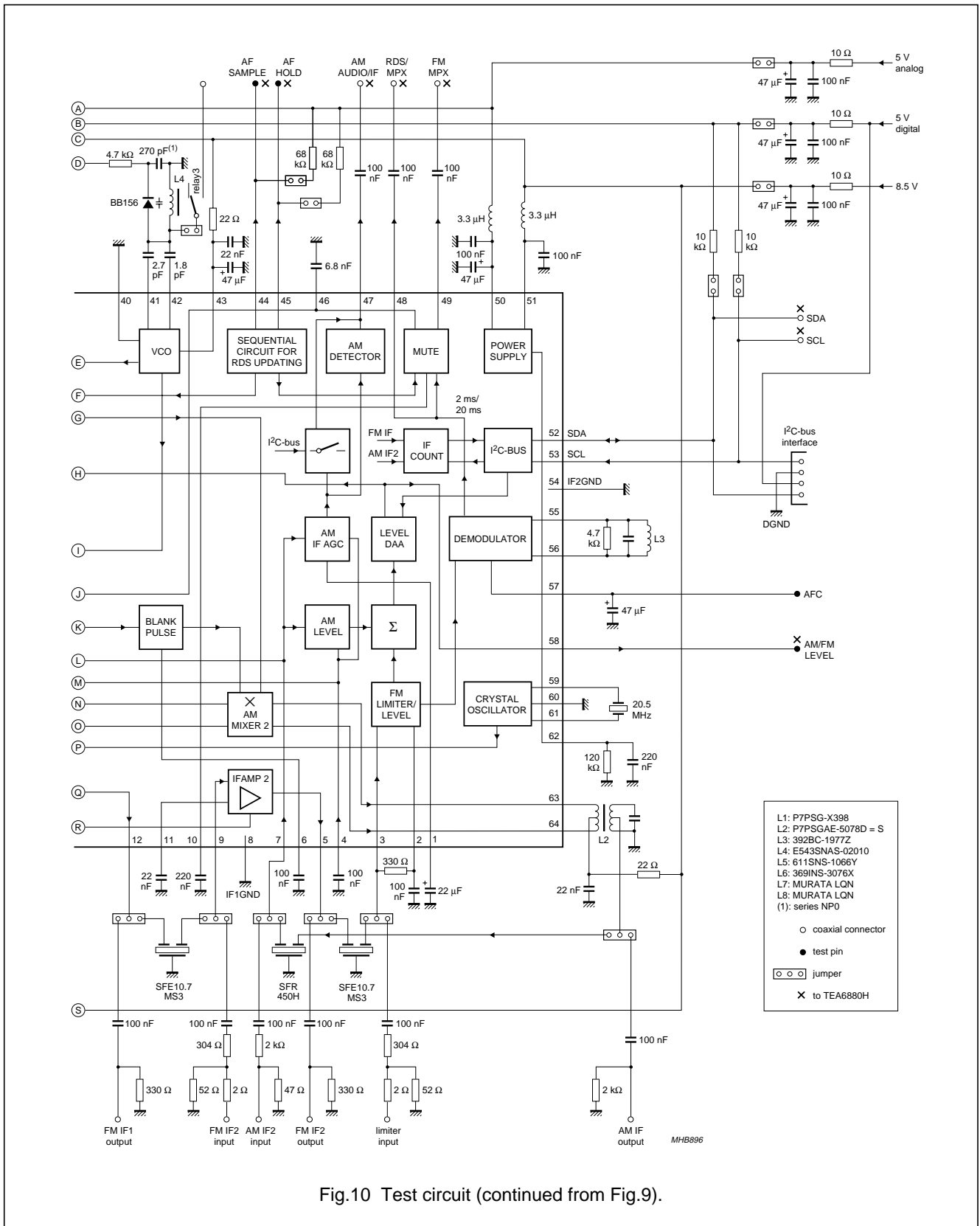

Fig.8 Application diagram (continued from Fig.7).

New In Car Entertainment (NICE) car radio

TEA6845H



New In Car Entertainment (NICE) car radio

TEA6845H

Table 25 DC operating points

SYMBOL	PIN	UNLOADED DC VOLTAGE (V)					
		AM MODE			FM MODE		
		MIN.	TYP.	MAX.	MIN.	TYP.	MAX.
C _{AGC}	1	3.6	4.3	4.8	4.1	4.6	5.1
FMLIMDEC	2	2.5	3	3.5	2.5	2.8	3.1
FMLIMIN	3	2.5	3	3.5	2.5	2.8	3.1
AMIF2DEC	4	2.4	2.7	3.2	floating		
IFAMP2OUT	5	7.2	7.9	–	3.4	3.9	4.4
AMNBHOLD	6	4.3	4.6	5.1	8	8.4	–
AMIF2IN	7	2.4	2.7	3.2	floating		
IF1GND	8	external 0			external 0		
IFAMP2IN	9	3	4	5	2.7	3.1	3.5
C _{offset}	10	floating			3	3.5	4
IFAMP2DEC	11	3	4	5	2.7	3.1	3.5
IFAMP1OUT	12	7.2	7.9	–	3.6	4	4.4
IFAMP1IN	13	2.4	2.7	3	2.3	2.7	3.1
V _{DDA6}	14	external 8.5			external 8.5		
IFAMP1DEC	15	2.4	2.7	3	2.3	2.7	3.1
MIX1OUT1	16	external 8.5			external 8.5		
MIX1OUT2	17	external 8.5			external 8.5		
V _{DDA5}	18	external 8.5			external 8.5		
AMMIX1IN1	19	2.3	2.75	3.1	floating		
AMMIX1IN2	20	2.3	2.75	3.1	floating		
T1AMAGC	21	0	2.8	4.6	0 (no WX)	0.3 (no WX)	0.5 (no WX)
T2AMAGC	22	2.5	2.8	3.1	floating		
IAMAGC	23	open-collector			open-collector		
V _{ref(FMMIX)}	24	2.7	3.1	3.4	6.5	7.1	7.9
FMMIXIN1	25	1	1.3	1.6	2.3	2.8	3.3
RFGND	26	external 0			external 0		
FMMIXIN2	27	1	1.3	1.6	2.3	2.8	3.3
IFMAGC	28	floating			1.5 (external biasing)	–	4 (external biasing)
T2FMAGC	29	7.5	8	8.3	3.9	4.6	5.3
T1FMAGC	30	floating			1	–	7
DAAOUT	31	–	0.2	0.3	0.2	–	8.25
DAATD	32	floating			0.2	–	1.5
DAAIN	33	0	–	8.5	0	–	8.5
V _{tune}	34	0	–	8.5	0	–	8.5
CPOUT	35	0	–	8.5	0	–	8.5
V _{DDA4}	36	external 8.5			external 8.5		

New In Car Entertainment (NICE) car radio

TEA6845H

SYMBOL	PIN	UNLOADED DC VOLTAGE (V)					
		AM MODE			FM MODE		
		MIN.	TYP.	MAX.	MIN.	TYP.	MAX.
FREF	37	3.2	3.4	3.7	3.2	3.4	3.7
V _{DDD}	38	external 5			external 5		
DGND	39	external 0			external 0		
VCOGND	40	external 0			external 0		
OSCFDB	41	2.2	2.8	3.4	2.2	2.8	3.4
OSCTNK	42	5	6.1	7.2	5	6.1	7.2
V _{DDA3}	43	external 8.5			external 8.5		
AFSAMPLE	44	0	0.2	0.5	0	0.2	0.5
AFHOLD	45	open-collector			open-collector		
TRDSMUTE	46	1.9	2.2	2.5	0.7 (muted)	1.2 (muted)	1.7 (muted)
					5.2 (not muted)	5.7 (not muted)	6.2 (not muted)
AMAFIF2	47	4	4.3	4.6	floating		
RDSMPX	48	floating			2.6	3.1	3.3
FMMPX	49	floating			3	3.5	4
V _{DDA2}	50	external 5			external 5		
V _{DDA1}	51	external 8.5			external 8.5		
SDA	52	4.8	5	5.2	4.8	5	5.2
SCL	53	4.8	5	5.2	4.8	5	5.2
IF2GND	54	external 0			external 0		
QDET1	55	floating			3.6	4.1	4.6
QDET2	56	floating			3.6	4.1	4.6
C _{AFC}	57	floating			1.2	3.4	4.1
V _{level}	58	0.05	–	7	0	–	7
XTAL1	59	1.7	2.1	2.5	1.7	2.1	2.5
XTALGND	60	external 0			external 0		
XTAL2	61	1.7	2.1	2.5	1.7	2.1	2.5
IREF	62	4	4.25	4.5	4	4.25	4.5
AMMIX2OUT1	63	external 8.5			external 8.5		
AMMIX2OUT2	64	external 8.5			external 8.5		

New In Car Entertainment (NICE) car radio

TEA6845H

14 PACKAGE OUTLINE

QFP64: plastic quad flat package; 64 leads (lead length 1.95 mm); body 14 x 20 x 2.8 mm

SOT319-2

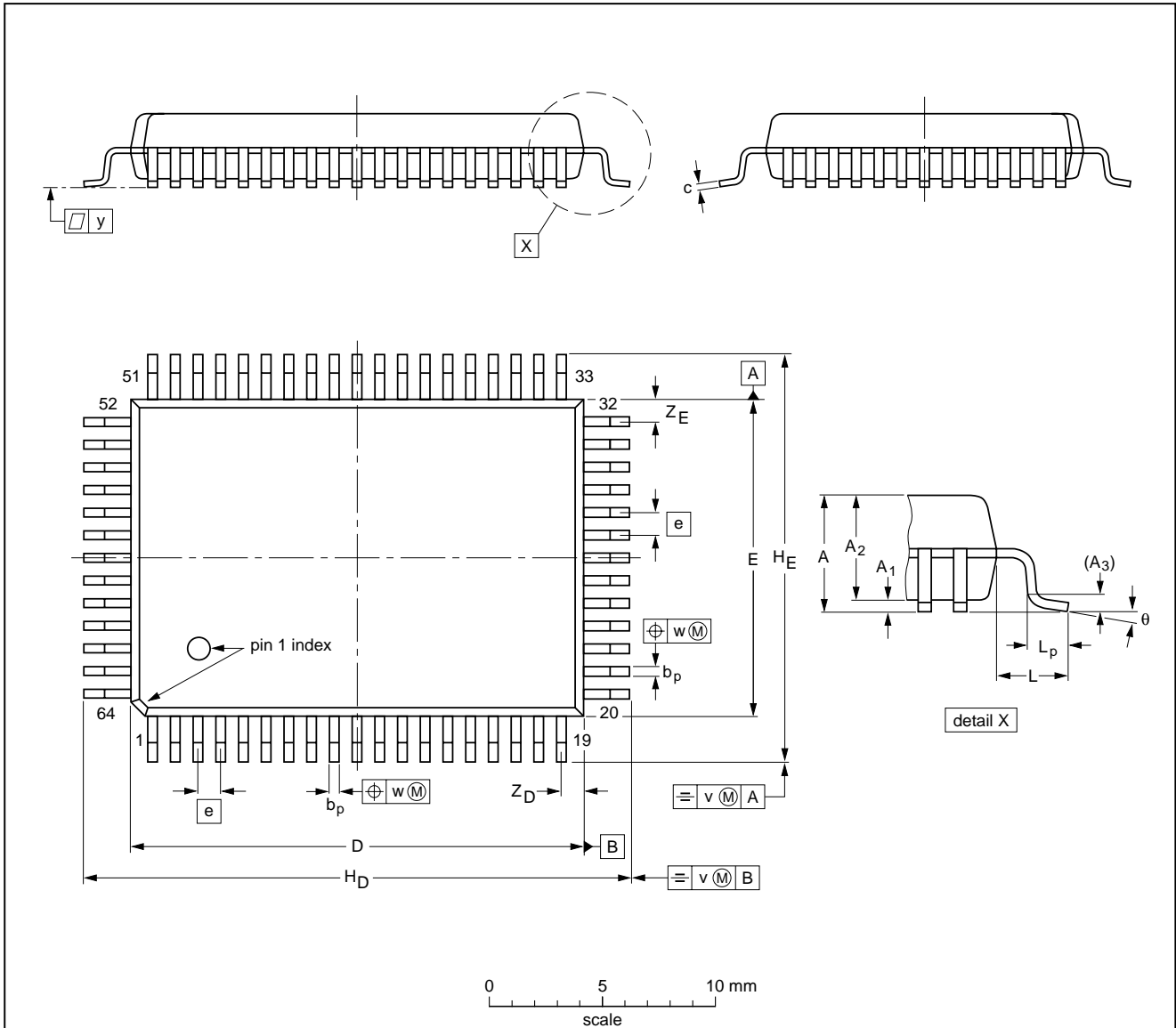

DIMENSIONS (mm are the original dimensions)

UNIT	A max.	A ₁	A ₂	A ₃	b _p	c	D ⁽¹⁾	E ⁽¹⁾	e	H _D	H _E	L	L _p	v	w	y	Z _D ⁽¹⁾	Z _E ⁽¹⁾	θ
mm	3.20	0.25 0.05	2.90 2.65	0.25	0.50 0.35	0.25 0.14	20.1 19.9	14.1 13.9	1	24.2 23.6	18.2 17.6	1.95	1.0 0.6	0.2	0.2	0.1	1.2 0.8	1.2 0.8	7° 0°

Note

1. Plastic or metal protrusions of 0.25 mm maximum per side are not included.

OUTLINE VERSION	REFERENCES				EUROPEAN PROJECTION	ISSUE DATE
	IEC	JEDEC	EIAJ			
SOT319-2		MO-112				97-08-01 99-12-27

New In Car Entertainment (NICE) car radio

TEA6845H

15 SOLDERING

15.1 Introduction to soldering surface mount packages

This text gives a very brief insight to a complex technology. A more in-depth account of soldering ICs can be found in our *"Data Handbook IC26; Integrated Circuit Packages"* (document order number 9398 652 90011).

There is no soldering method that is ideal for all surface mount IC packages. Wave soldering can still be used for certain surface mount ICs, but it is not suitable for fine pitch SMDs. In these situations reflow soldering is recommended.

15.2 Reflow soldering

Reflow soldering requires solder paste (a suspension of fine solder particles, flux and binding agent) to be applied to the printed-circuit board by screen printing, stencilling or pressure-syringe dispensing before package placement.

Several methods exist for reflowing; for example, convection or convection/infrared heating in a conveyor type oven. Throughput times (preheating, soldering and cooling) vary between 100 and 200 seconds depending on heating method.

Typical reflow peak temperatures range from 215 to 250 °C. The top-surface temperature of the packages should preferably be kept below 220 °C for thick/large packages, and below 235 °C for small/thin packages.

15.3 Wave soldering

Conventional single wave soldering is not recommended for surface mount devices (SMDs) or printed-circuit boards with a high component density, as solder bridging and non-wetting can present major problems.

To overcome these problems the double-wave soldering method was specifically developed.

If wave soldering is used the following conditions must be observed for optimal results:

- Use a double-wave soldering method comprising a turbulent wave with high upward pressure followed by a smooth laminar wave.
- For packages with leads on two sides and a pitch (e):
 - larger than or equal to 1.27 mm, the footprint longitudinal axis is **preferred** to be parallel to the transport direction of the printed-circuit board;
 - smaller than 1.27 mm, the footprint longitudinal axis **must** be parallel to the transport direction of the printed-circuit board.

The footprint must incorporate solder thieves at the downstream end.

- For packages with leads on four sides, the footprint must be placed at a 45° angle to the transport direction of the printed-circuit board. The footprint must incorporate solder thieves downstream and at the side corners.

During placement and before soldering, the package must be fixed with a droplet of adhesive. The adhesive can be applied by screen printing, pin transfer or syringe dispensing. The package can be soldered after the adhesive is cured.

Typical dwell time is 4 seconds at 250 °C.

A mildly-activated flux will eliminate the need for removal of corrosive residues in most applications.

15.4 Manual soldering

Fix the component by first soldering two diagonally-opposite end leads. Use a low voltage (24 V or less) soldering iron applied to the flat part of the lead. Contact time must be limited to 10 seconds at up to 300 °C.

When using a dedicated tool, all other leads can be soldered in one operation within 2 to 5 seconds between 270 and 320 °C.

New In Car Entertainment (NICE) car radio

TEA6845H

15.5 Suitability of surface mount IC packages for wave and reflow soldering methods

PACKAGE ⁽¹⁾	SOLDERING METHOD	
	WAVE	REFLOW ⁽²⁾
BGA, LBGA, LFBGA, SQFP, TFBGA, VFBGA	not suitable	suitable
DHVQFN, HBCC, HBGA, HLQFP, HSQFP, HSOP, HTQFP, HTSSOP, HVQFN, HVSON, SMS	not suitable ⁽³⁾	suitable
PLCC ⁽⁴⁾ , SO, SOJ	suitable	suitable
LQFP, QFP, TQFP	not recommended ⁽⁴⁾⁽⁵⁾	suitable
SSOP, TSSOP, VSO	not recommended ⁽⁶⁾	suitable

Notes

1. For more detailed information on the BGA packages refer to the “(LF)BGA Application Note” (AN01026); order a copy from your Philips Semiconductors sales office.
2. All surface mount (SMD) packages are moisture sensitive. Depending upon the moisture content, the maximum temperature (with respect to time) and body size of the package, there is a risk that internal or external package cracks may occur due to vaporization of the moisture in them (the so called popcorn effect). For details, refer to the Drypack information in the “Data Handbook IC26; Integrated Circuit Packages; Section: Packing Methods”.
3. These packages are not suitable for wave soldering. On versions with the heatsink on the bottom side, the solder cannot penetrate between the printed-circuit board and the heatsink. On versions with the heatsink on the top side, the solder might be deposited on the heatsink surface.
4. If wave soldering is considered, then the package must be placed at a 45° angle to the solder wave direction. The package footprint must incorporate solder thieves downstream and at the side corners.
5. Wave soldering is suitable for LQFP, TQFP and QFP packages with a pitch (e) larger than 0.8 mm; it is definitely not suitable for packages with a pitch (e) equal to or smaller than 0.65 mm.
6. Wave soldering is suitable for SSOP and TSSOP packages with a pitch (e) equal to or larger than 0.65 mm; it is definitely not suitable for packages with a pitch (e) equal to or smaller than 0.5 mm.

New In Car Entertainment (NICE) car radio

TEA6845H

16 DATA SHEET STATUS

LEVEL	DATA SHEET STATUS ⁽¹⁾	PRODUCT STATUS ⁽²⁾⁽³⁾	DEFINITION
I	Objective data	Development	This data sheet contains data from the objective specification for product development. Philips Semiconductors reserves the right to change the specification in any manner without notice.
II	Preliminary data	Qualification	This data sheet contains data from the preliminary specification. Supplementary data will be published at a later date. Philips Semiconductors reserves the right to change the specification without notice, in order to improve the design and supply the best possible product.
III	Product data	Production	This data sheet contains data from the product specification. Philips Semiconductors reserves the right to make changes at any time in order to improve the design, manufacturing and supply. Relevant changes will be communicated via a Customer Product/Process Change Notification (CPCN).

Notes

1. Please consult the most recently issued data sheet before initiating or completing a design.
2. The product status of the device(s) described in this data sheet may have changed since this data sheet was published. The latest information is available on the Internet at URL <http://www.semiconductors.philips.com>.
3. For data sheets describing multiple type numbers, the highest-level product status determines the data sheet status.

17 DEFINITIONS

Short-form specification — The data in a short-form specification is extracted from a full data sheet with the same type number and title. For detailed information see the relevant data sheet or data handbook.

Limiting values definition — Limiting values given are in accordance with the Absolute Maximum Rating System (IEC 60134). Stress above one or more of the limiting values may cause permanent damage to the device. These are stress ratings only and operation of the device at these or at any other conditions above those given in the Characteristics sections of the specification is not implied. Exposure to limiting values for extended periods may affect device reliability.

Application information — Applications that are described herein for any of these products are for illustrative purposes only. Philips Semiconductors make no representation or warranty that such applications will be suitable for the specified use without further testing or modification.

18 DISCLAIMERS

Life support applications — These products are not designed for use in life support appliances, devices, or systems where malfunction of these products can reasonably be expected to result in personal injury. Philips Semiconductors customers using or selling these products for use in such applications do so at their own risk and agree to fully indemnify Philips Semiconductors for any damages resulting from such application.

Right to make changes — Philips Semiconductors reserves the right to make changes in the products - including circuits, standard cells, and/or software - described or contained herein in order to improve design and/or performance. When the product is in full production (status 'Production'), relevant changes will be communicated via a Customer Product/Process Change Notification (CPCN). Philips Semiconductors assumes no responsibility or liability for the use of any of these products, conveys no licence or title under any patent, copyright, or mask work right to these products, and makes no representations or warranties that these products are free from patent, copyright, or mask work right infringement, unless otherwise specified.

New In Car Entertainment (NICE) car radio**TEA6845H**

19 PURCHASE OF PHILIPS I²C COMPONENTS

Purchase of Philips I²C components conveys a license under the Philips' I²C patent to use the components in the I²C system provided the system conforms to the I²C specification defined by Philips. This specification can be ordered using the code 9398 393 40011.

New In Car Entertainment (NICE) car radio

TEA6845H

NOTES

New In Car Entertainment (NICE) car radio

TEA6845H

NOTES

New In Car Entertainment (NICE) car radio

TEA6845H

NOTES

Philips Semiconductors – a worldwide company

Contact information

For additional information please visit <http://www.semiconductors.philips.com>. Fax: +31 40 27 24825

For sales offices addresses send e-mail to: sales.addresses@www.semiconductors.philips.com.

© Koninklijke Philips Electronics N.V. 2003

SCA75

All rights are reserved. Reproduction in whole or in part is prohibited without the prior written consent of the copyright owner.

The information presented in this document does not form part of any quotation or contract, is believed to be accurate and reliable and may be changed without notice. No liability will be accepted by the publisher for any consequence of its use. Publication thereof does not convey nor imply any license under patent- or other industrial or intellectual property rights.

Printed in The Netherlands

753503/02/pp48

Date of release: 2003 Feb 04

Document order number: 9397 750 10556

Let's make things better.

**Philips
Semiconductors**



PHILIPS