

LM2406 Monolithic Triple 9 ns CRT Driver

General Description

The LM2406 is an integrated high voltage CRT driver circuit designed for use in color monitor applications. The IC contains three high input impedance, wide band amplifiers which directly drive the RGB cathodes of a CRT. The gain of each channel is internally set at -14.5 and can drive CRT capacitive loads as well as resistive loads presented by other applications, limited only by the package's power dissipation.

The IC is packaged in an industry standard 11 lead TO-220 molded plastic power package. See thermal considerations on page 4.

Features

- Output swing capability: 50 V_{PP} for V_{CC} = 80
40 V_{PP} for V_{CC} = 70
30 V_{PP} for V_{CC} = 60
- Pinout designed for easy PCB layout
- 1V to 7V input range
- Stable with 0 pF–20 pF capacitive loads
- Convenient TO-220 staggered lead style package

Applications

- CRT driver for 1024 x 768 (Non-interlaced) and SVGA display resolution color monitors
- Pixel clock frequency up to 80 MHz

Schematic and Connection Diagrams

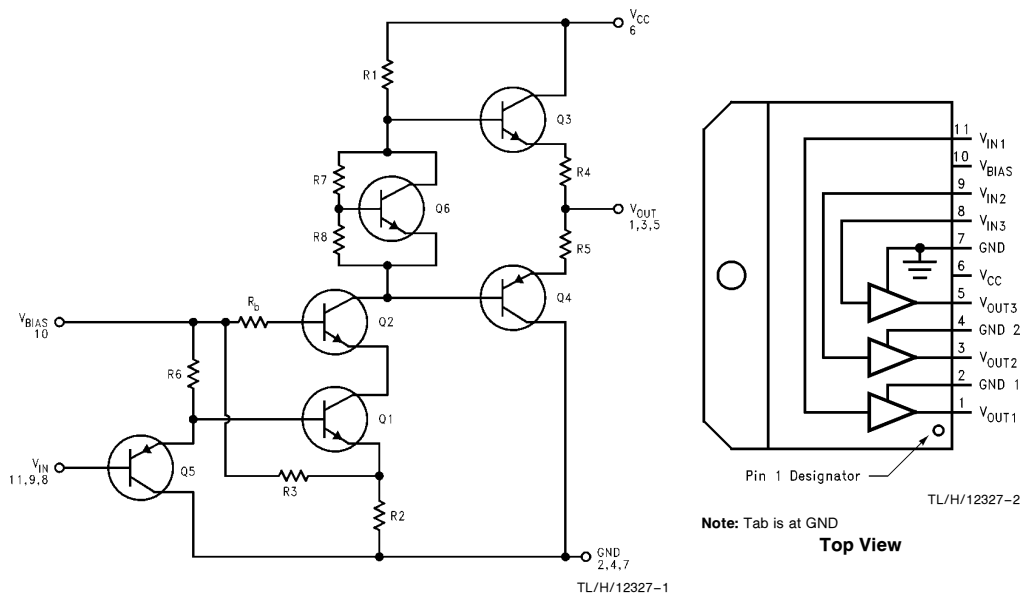

FIGURE 1. Simplified Schematic Diagram (One Channel)

Absolute Maximum Ratings (Notes 1, 3)

Supply Voltage, V_{CC}	+95V
Bias Voltage, V_{BIAS}	+16V
Input Voltage, V_{IN}	-0.5V to V_{BIAS} + 0.5V
Storage Temperature Range, T_{STG}	-65°C to +150°C
Lead Temperature (Soldering, <10 sec.)	300°C
ESD Tolerance	2 kV

Operating Range (Note 2)

V_{CC}	+60V to +85V
V_{BIAS}	+8V to +15V
V_{IN}	+1V to +7V
Case Temperature, T_{CASE}	-20°C to +100°C
Do not operate the part without a heat sink	

Electrical Characteristics

Unless otherwise noted: $V_{CC} = +80V$, $V_{BIAS} = +12V$, $V_{IN} = +3.3V$, $C_L = 8\text{ pF}$, Output = 40 V_{PP} at 1 MHz, $T_A = 25^\circ\text{C}$.

Symbol	Parameter	Conditions	LM2406			Units
			Min	Typical	Max	
I_{CC}	Supply Current (Per Channel)	No Output Load		18	30	mA
V_{OUT}	Output Voltage	No Input Signal	45	50	55	V _{DC}
t_R	Rise Time	10%–90%, $f = 1\text{ MHz}$		9		nS
t_F	Fall Time	90%–10%, $f = 1\text{ MHz}$		9		nS
A_V	Voltage Gain		-13	-14.5	-16	V/V
LE	Linearity Error	(Note 4)		8		%
ΔA_V	Gain Matching	(Note 5)		1.0		dB

Note 1: Absolute Maximum Ratings indicate limits beyond which damage to the device may occur.

Note 2: Operating ratings indicate conditions for which the device is functional, but do not guarantee specific performance limits. For guaranteed specifications and test conditions, see the Electrical Characteristics. The guaranteed specifications apply only for the test conditions listed. Some performance characteristics may change when the device is not operated under the listed test conditions.

Note 3: All voltages are measured with respect to GND, unless otherwise specified.

Note 4: Linearity Error is defined as the variation in small signal gain from +30V to +70V output with a 100 mV AC, 10 kHz input signal.

Note 5: Calculated value from Voltage Gain test on each channel.

Note 6: Input signal, V_{IN} ; t_r , $t_f < 2\text{ nS}$.

AC Test Circuit

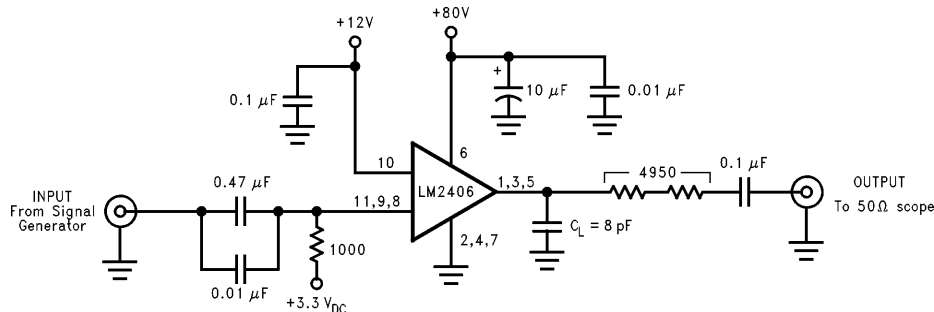

TL/H/12327-3

Note: 8 pF is total load including parasitic capacitance.

FIGURE 2. Test Circuit (One Channel)

Figure 2 shows a typical test circuit for evaluation of the LM2406. This circuit is designed to allow testing of the LM2406 in a 50 Ω environment, such as a pulse generator, oscilloscope or network analyzer. The two series resistors at the output form a 100:1 voltage divider when connected to a 50 Ω load.

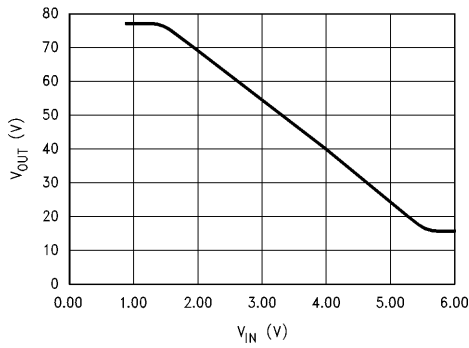

FIGURE 3. V_{OUT} vs V_{IN}

TL/H/12327-4

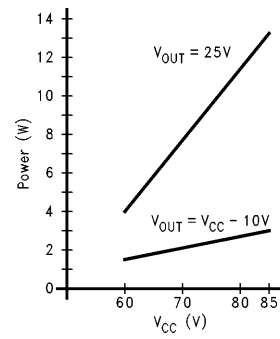

FIGURE 4. Power Dissipation vs V_{CC}

TL/H/12327-5

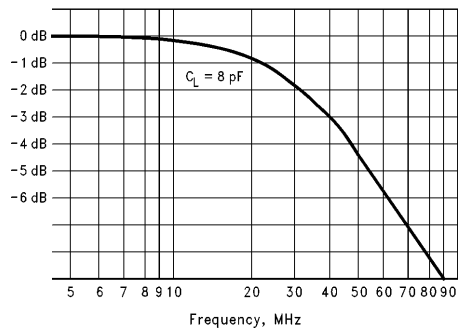

FIGURE 5. Large Signal Frequency Response

TL/H/12327-6

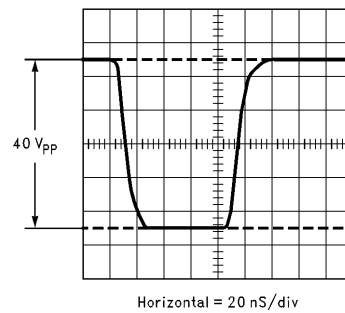

FIGURE 6. Pulse Response

TL/H/12327-7

Theory of Operation

The LM2406 is a high voltage monolithic triple CRT driver suitable for VGA and SVGA display applications. The LM2406 features +80V operation and low power dissipation. The part is housed in the industry standard 11-lead TO-220 molded plastic power package.

The circuit diagram of the LM2406 is shown in *Figure 1*. Q1 and R2 provide a conversion of input voltage to current, while Q2 acts as a common base or cascode amplifier stage to drive the load resistor R1. Emitter followers Q3 and Q4 isolate the impedance of R1 from the capacitance of the CRT cathode, and make the circuit relative insensitive to load capacitance. The gain of this circuit is $-R1/(R2||R3)$ and is fixed at -14.5 . The bandwidth of the circuit is set by the collector time constant formed by the resistor R1 and

associated capacitance of Q2, Q3, Q4 and stray layout capacitance. Transistor Q6 and resistors R7 and R8 provide biasing to the output emitter-follower stage to reduce crossover distortion at low signal levels, while R3 provides a DC bias offset to match the output level characteristics of the preamplifier stage.

Figure 2 shows a typical test circuit for evaluation of the LM2406. This circuit is designed to allow testing of the LM2406 in a 50Ω environment, such as a pulse generator and a scope, or a network analyzer. In this test circuit, two resistors in series totaling $4.95\text{ k}\Omega$ form a 100:1 wideband low capacitance probe when connected to a 50Ω cable and load. The input signal from the generator is AC coupled to the base of Q5, while a DC bias of +12V is applied to the base of Q2 (See *Figure 2*).

Application Hints

POWER SUPPLY BYPASS

Since the LM2406 is a wide bandwidth amplifier, proper power supply bypassing is critical for optimum performance. Improper power supply bypassing can result in large overshoot, ringing and oscillation. A 0.01 μF capacitor should be connected as close to the supply pin, $V+$, as is practical (preferably less than $\frac{1}{4}$ " from the supply pin). Additionally, a 10 μF –100 μF electrolytic capacitor should be connected from the supply pin to ground. The electrolytic capacitor should also be placed reasonably close to the LM2406's supply pin. A 0.1 μF capacitor should be connected from the bias pin to ground, as close as is practical to the LM2406.

The LM2406 is short circuit proof to momentary shorts to ground (< 1 sec.).

ARC PROTECTION

During normal CRT operation, internal arcing may occasionally occur. Spark gaps of 200V–300V at the cathodes will limit the maximum voltage, but to a value that is much higher than allowable on the LM2406. This fast, high voltage, high energy pulse can damage the LM2406 output stage. The addition of clamp diodes D1 and D2 (as shown in *Figure 7*) will help clamp the voltage at the output of the LM2406 to a safe level. The clamp diodes should have a fast transient response, high peak current rating, low series impedance and low shunt capacitance. FDH400 or equivalent diodes are recommended. Resistor R2 in *Figure 7* limits the arcover current while R1 limits the current into the LM2406 and reduces the power dissipation of the output transistors when the output is stressed beyond the supply voltage. Having large value resistors for R1 and R2 would be desirable, but this has the effect of increasing rise and fall times.

IMPROVING RISE AND FALL TIMES

Because of an emitter follower output stage, the rise and fall times of the LM2406 are relatively insensitive to capacitive loading. However, the series resistors R1 and R2 (see *Figure 7*) will increase the rise and fall times when driving the CRT's cathode which appears as a capacitive load. The capacitance at the cathode typically ranges from 8 pF–12 pF.

To improve the rise and fall times at the cathode, a small inductor is often used in series with the output of the amplifier. The inductor L_p in *Figure 7* peaks the amplifier's frequency response at the cathode, thus improving rise and fall times. The inductor value is empirically determined and is dependent on the load. An inductor value of 0.1 μH is a good starting value. Note that peaking the amplifier's frequency response will increase the overshoot.

THERMAL CONSIDERATIONS

Power supply current increases as the input signal increases and consequently power dissipation also increases.

The LM2406 cannot be used without heat sinking. Typical "average" power dissipation with the device output voltage at one half the supply voltage is 2.4W per channel for a total dissipation of 7.2W package dissipation. Under white screen conditions, i.e., 25V output, dissipation increases to 3.5W per channel or 10.5W total. The LM2406 case temperature must be maintained below 100°C. If the maximum expected ambient temperature is 50°C, then a maximum heat sink thermal resistance can be calculated:

$$R_{th} = \frac{100^{\circ}\text{C} - 50^{\circ}\text{C}}{10.5\text{W}} = 4.76^{\circ}\text{C}/\text{W}.$$

This example assumes a typical CRT capacitive load and is without a resistive load.

TYPICAL APPLICATION

A typical application of the LM2406 is shown in *Figure 8*. Used in conjunction with an LM1207, a complete video channel from monitor input to CRT cathode can be achieved. Performance is satisfactory for all applications up to 1024 x 768 non-interlaced.

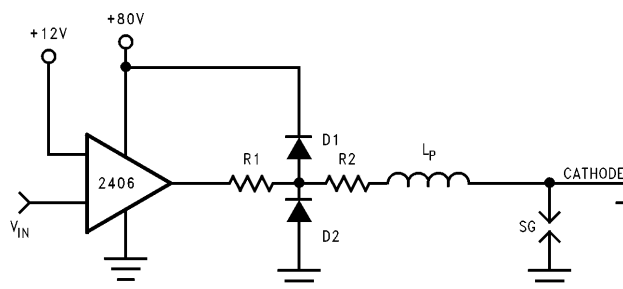

TL/H/12327-8

FIGURE 7. One Section of the LM2406 with Arc Protection and Peaking Inductor L_p

Typical Applications

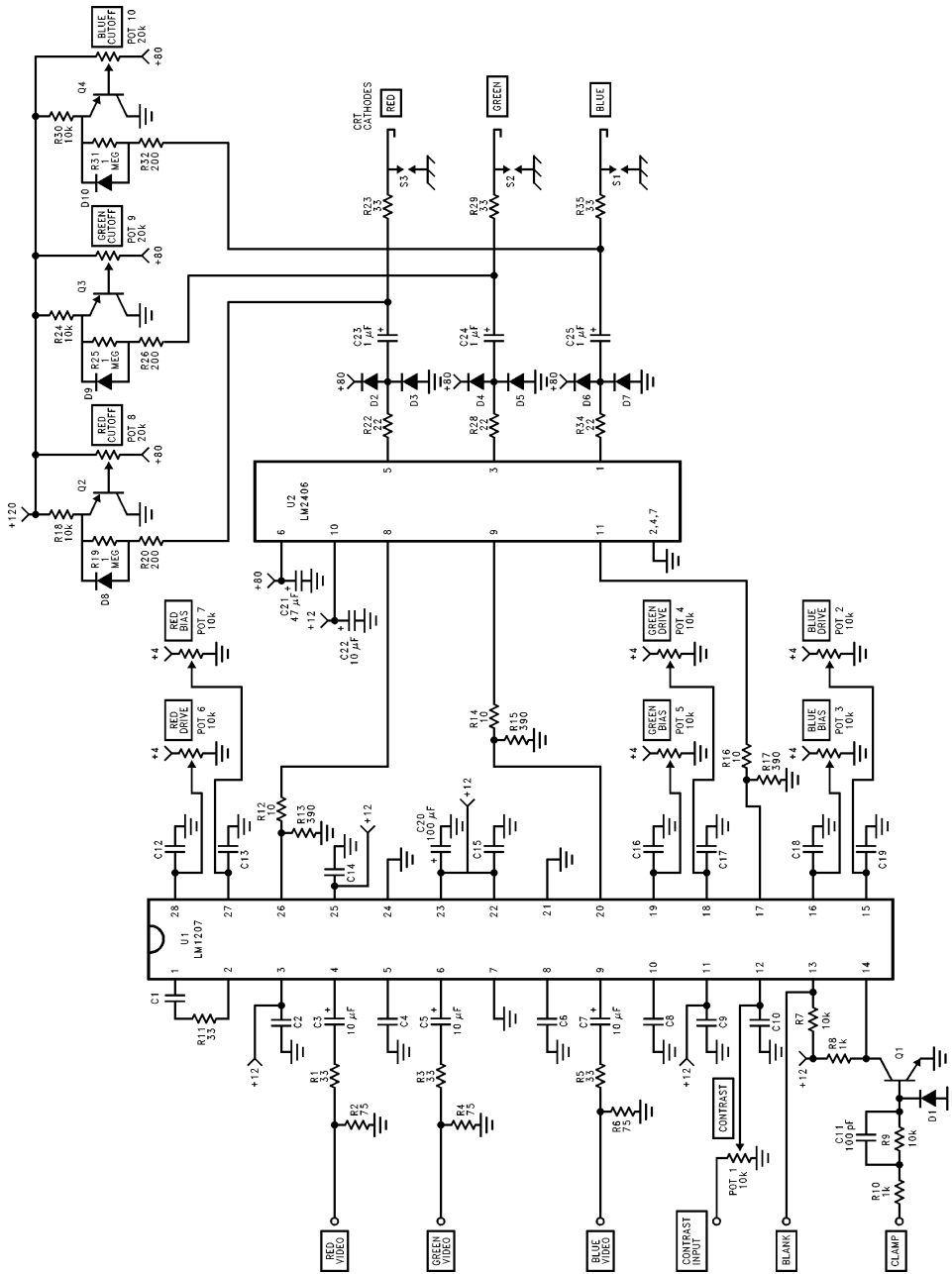

TL/H/12327-9

FIGURE 8. Typical Application LM1207-LM2406

Note: Unmarked capacitors 0.1 μF

LM2406 Monolithic 9 ns Triple CRT Driver

Physical Dimensions inches (millimeters)

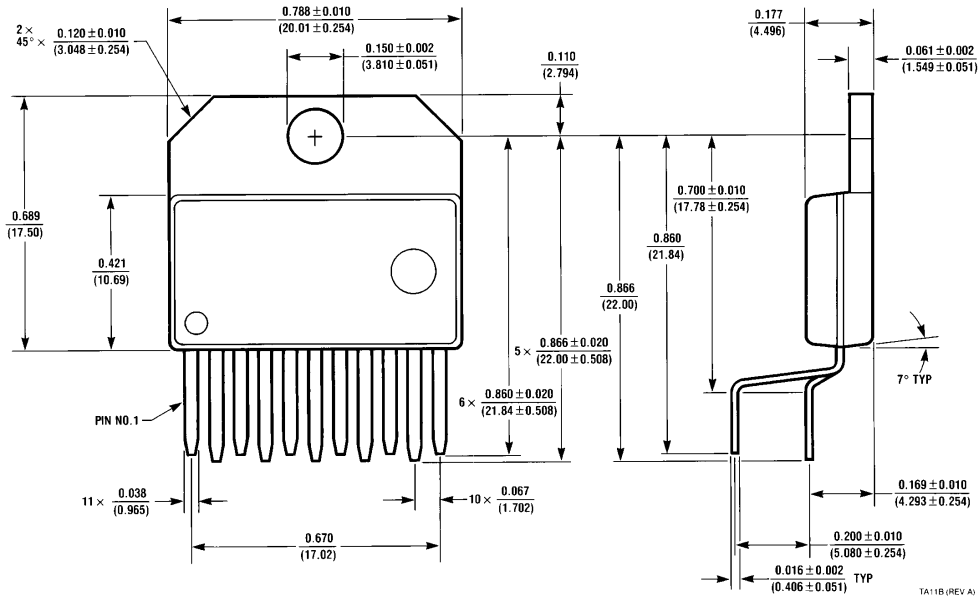

11-Lead Molded TO-220
Order Number LM2406
NS Package Number TA11B

LIFE SUPPORT POLICY

NATIONAL'S PRODUCTS ARE NOT AUTHORIZED FOR USE AS CRITICAL COMPONENTS IN LIFE SUPPORT DEVICES OR SYSTEMS WITHOUT THE EXPRESS WRITTEN APPROVAL OF THE PRESIDENT OF NATIONAL SEMICONDUCTOR CORPORATION. As used herein:

1. Life support devices or systems are devices or systems which, (a) are intended for surgical implant into the body, or (b) support or sustain life, and whose failure to perform, when properly used in accordance with instructions for use provided in the labeling, can be reasonably expected to result in a significant injury to the user.
2. A critical component is any component of a life support device or system whose failure to perform can be reasonably expected to cause the failure of the life support device or system, or to affect its safety or effectiveness.



National Semiconductor Corporation
 1111 West Bardin Road
 Arlington, TX 76017
 Tel: 1(800) 272-9959
 Fax: 1(800) 737-7018

National Semiconductor Europe
 Fax: (+49) 0-180-530 85 86
 Email: cnjwge@tevm2.nsc.com
 Deutsch Tel: (+49) 0-180-530 85 85
 English Tel: (+49) 0-180-532 78 32
 Français Tel: (+49) 0-180-532 93 58
 Italiano Tel: (+49) 0-180-534 16 80

National Semiconductor Hong Kong Ltd.
 19th Floor, Straight Block,
 Ocean Centre, 5 Canton Rd.
 Tsimshatsui, Kowloon
 Hong Kong
 Tel: (852) 2737-1600
 Fax: (852) 2736-9960

National Semiconductor Japan Ltd.
 Tel: 81-043-299-2309
 Fax: 81-043-299-2408

National does not assume any responsibility for use of any circuitry described, no circuit patent licenses are implied and National reserves the right at any time without notice to change said circuitry and specifications.