

# M62393P/FP

## 8-BIT 8CH I<sup>2</sup>C-BUS D-A CONVERTER WITH BUFFER AMPLIFIERS

### DESCRIPTION

The M62393 is an integrated circuit semiconductor of CMOS structure with 8 channels of built-in D-A converters with output buffer operational amplifiers.

The input is 2-wires serial method is used for the transfer format of digital data to allow connection with a microcomputer with minimum wiring.

The output buffer operational amplifier employs AB class output circuit with sync and source drive capacity of 1.0mA or more, and it operates in the whole voltage range from VrefU to ground.

And because of connects maximum 8 pieces to 64 channels control.

### FEATURES

- Digital data transfer format  
I<sup>2</sup>C-bus serial data method
- Output buffer operational amplifier  
it operates in the whole voltage range from VrefU(0 to 5V)to ground.
- High output current drive capacity  
±1.0mA over
- Preparation two high level reference voltage terminal  
because there are two high level reference voltage terminal,it can set up two kinds differ voltage range.

### APPLICATION

Conversion from digital control data to analog control data for home-use and industrial equipment.

Signal gain control or automatic adjustment of DISPLAY-MONITOR or CTV.

### PIN CONFIGURATION (TOP VIEW)

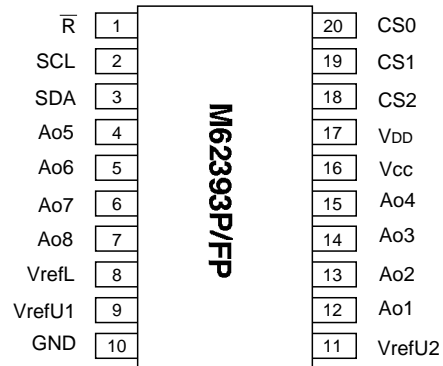

Outline 20P4(P)  
20P2N-A(FP)

### BLOCK DIAGRAM

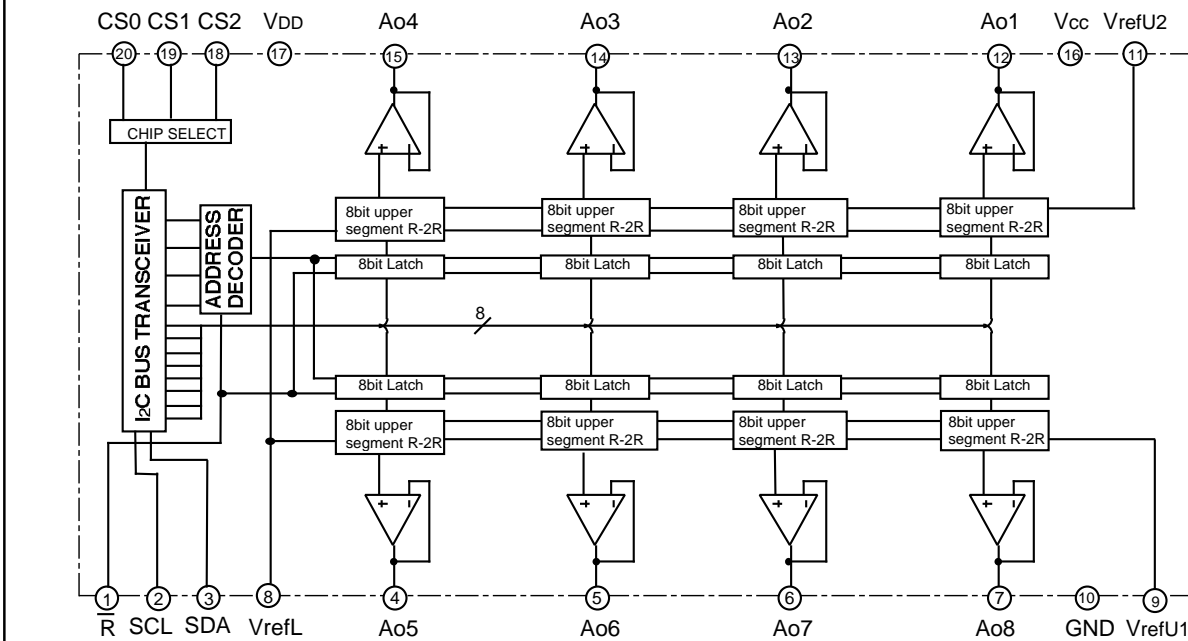

# M62393P/FP

## 8-BIT 8CH I<sup>2</sup>C-BUS D-A CONVERTER WITH BUFFER AMPLIFIERS

### EXPLANATION OF TERMINALS

Pin No.	Symbol	Function
③	SDA	Serial data input terminal
①	$\bar{R}$	Reset signal input terminal
②	SCL	Serial clock input terminal
⑫	Ao1	8-bit D-A converter output terminal
⑬	Ao2	
⑭	Ao3	
⑮	Ao4	
④	Ao5	
⑤	Ao6	
⑥	Ao7	
⑦	Ao8	
⑯	Vcc	Analog power supply terminal
⑰	VDD	Digital power supply terminal
⑩	GND	Analog and digital common GND
⑧	VrefL	D-A converter low level reference voltage input terminal
⑨	VrefU1	D-A converter high level reference voltage input terminal 1
⑪	VrefU2	D-A converter high level reference voltage input terminal 2
⑱	CS2	Chip select data input terminal 2
⑲	CS1	Chip select data input terminal 1
⑳	CS0	Chip select data input terminal 0

# M62393P/FP

## 8-BIT 8CH I<sup>2</sup>C-BUS D-A CONVERTER WITH BUFFER AMPLIFIERS

### ABSOLUTE MAXIMUM RATINGS

Symbol	Parameter	Conditions	Ratings	Unit
V <sub>CC</sub>	Supply voltage		-0.3 to +7.0	V
V <sub>DD</sub>	Supply voltage		-0.3 to +7.0	V
V <sub>refU1,2</sub>	D-A converter high level reference voltage		-0.3 to +7.0	V
V <sub>IN</sub>	Input voltage		-0.3 to V <sub>DD</sub> +0.3	V
V <sub>O</sub>	Output voltage		-0.3 to V <sub>DD</sub> +0.3	V
P <sub>d</sub>	Power dissipation		990(DIP)/590(FP)	mW
T <sub>opr</sub>	Operating temperature		-20 to +85	°C
T <sub>stg</sub>	Storage temperature		-55 to +125	°C

### ELECTRICAL CHARACTERISTICS

**Digital part**(V<sub>CC</sub>,V<sub>DD</sub>,V<sub>refU1,2</sub>=+5V±10%,V<sub>CC</sub>≥V<sub>refU1,2</sub>,GND=V<sub>refL</sub>=0V,T<sub>a</sub>=-20 to +85°C,unless otherwise noted)

Symbol	Parameter	Test conditions	Limits			Unit
			Min.	Typ.	Max.	
V <sub>DD</sub>	Supply voltage		4.5	5.0	5.5	V
I <sub>DD</sub>	Supply current	CLK=1MHz operation I <sub>AO</sub> =0μA				mA
I <sub>ILK</sub>	Input leak current	V <sub>IN</sub> =0 to V <sub>CC</sub>	-10		10	μA
V <sub>IL</sub>	Input low voltage				0.2V <sub>CC</sub>	V
V <sub>IH</sub>	Input high voltage		0.8V <sub>CC</sub>			V

**Analog part**(V<sub>CC</sub>,V<sub>DD</sub>,V<sub>refU1,2</sub>=+5V±10%,V<sub>CC</sub>≥V<sub>refU1,2</sub>,GND=V<sub>refL</sub>=0V,T<sub>a</sub>=-20 to +85°C,unless otherwise noted)

Symbol	Parameter	Test conditions	Limits			Unit
			Min.	Typ.	Max.	
V <sub>CC</sub>	Supply voltage		4.5	5.0	5.5	V
I <sub>CC</sub>	Supply current	CLK=1MHz operation I <sub>AO</sub> =0μA				mA
I <sub>refU</sub>	D-A converter high level reference voltage input current	V <sub>refU</sub> =5V V <sub>refL</sub> =0V Data condition:at maximum current				mA
V <sub>refU</sub>	D-A converter high level reference voltage range	The output does not necessarily be the values within the reference voltage setting range.	3.5		V <sub>CC</sub>	V
V <sub>refL</sub>	D-A converter low level reference voltage range		GND		V <sub>CC</sub> -3.5	V
V <sub>AO</sub>	Buffer amplifier output voltage range	I <sub>AO</sub> =±100μA	0.1		V <sub>CC</sub> -0.1	V
		I <sub>AO</sub> =±500μA	0.2		V <sub>CC</sub> -0.2	
I <sub>AO</sub>	Buffer amplifier output current range	Upper side saturation voltage=0.3V Lower side saturation voltage=0.2V	-1.0		1.0	mA
S <sub>DL</sub>	Differential nonlinearity	V <sub>refU</sub> =4.79V	-1.0		1.0	LSB
S <sub>L</sub>	Nonlinearity	V <sub>refL</sub> =0.95V	-1.5		1.5	LSB
S <sub>ZERO</sub>	Zero code error	V <sub>CC</sub> =5.5V(15mV/LSB)	-2.0		2.0	LSB
S <sub>FULL</sub>	Full scale error	without load(I <sub>AO</sub> =0)	-2.0		2.0	LSB
C <sub>O</sub>	Output capacitive load				0.1	μF
R <sub>O</sub>	Buffer amplifier output impedance			5.0		Ω

# M62393P/FP

## 8-BIT 8CH I<sup>2</sup>C-BUS D-A CONVERTER WITH BUFFER AMPLIFIERS

### I<sup>2</sup>C-BUS LINE CHARACTERISTICS

Symbol	Parameter	Normal mode		High speed mode		Unit
		Min	Max	Min	Max	
f <sub>SCL</sub>	SCL clock frequency	0	100	0	400	kHz
t <sub>BUF</sub>	Time the bus must be free before a new transmission can start	4.7	—	1.3	—	μs
t <sub>HD:STA</sub>	Hold time start condition.After this period.The first clock pulse is generated	4.0	—	0.6	—	μs
t <sub>LOW</sub>	The low period of the clock	4.7	—	1.3	—	μs
t <sub>HIGH</sub>	The high period of the clock	4.0	—	0.6	—	μs
t <sub>SU:STA</sub>	Set up time for start condition(only relevant for a repeated start condition)	4.7	—	4.7	—	μs
t <sub>HD:DAT</sub>	Hold time data	0	—	0	0.9	μs
t <sub>SU:DAT</sub>	Set up time data	250	—	100	—	ns
t <sub>R</sub>	Rise time of both SDA and SCL lines		1000	20	300	ns
t <sub>F</sub>	Fall time of both SDA and SCL lines		300	20	300	ns
t <sub>SU:STO</sub>	Set up time for stop condition	4.0	—	0.6	—	μs

\*Note that transmitter must internally at reset a hold time to bridge the undefined region(max.300ns)of the falling edge of SCL.

### TIMING CHART

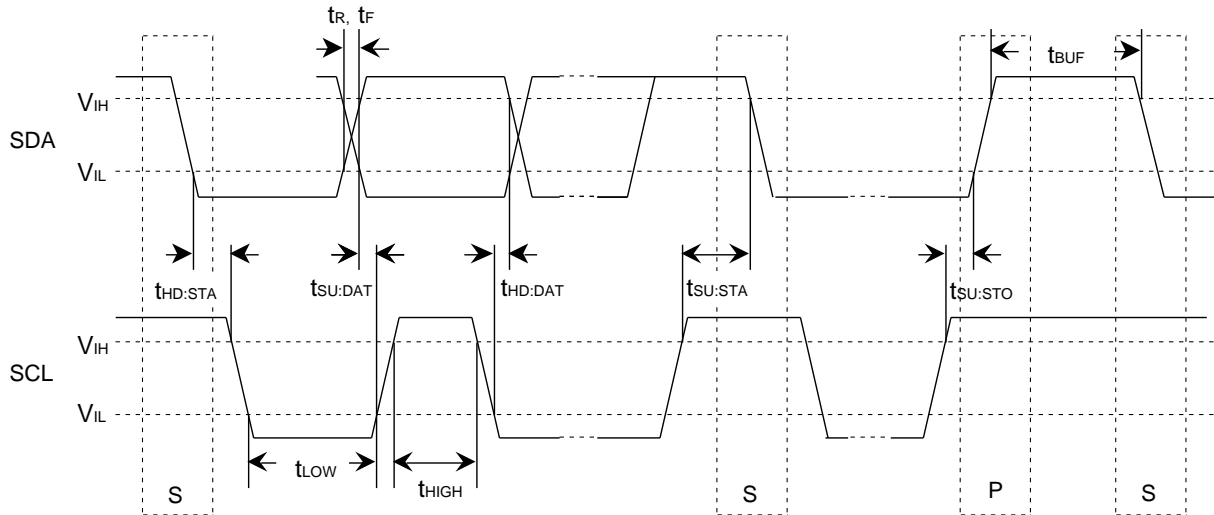

# M62393P/FP

## 8-BIT 8CH I<sup>2</sup>C-BUS D-A CONVERTER WITH BUFFER AMPLIFIERS

### I<sup>2</sup>C BUS FORMAT



### DIGITAL DATA FORMAT

•SLAVE ADDRESS

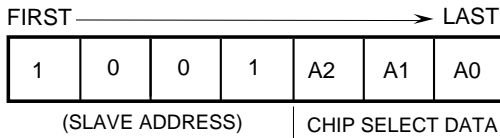

•SUB ADDRESS

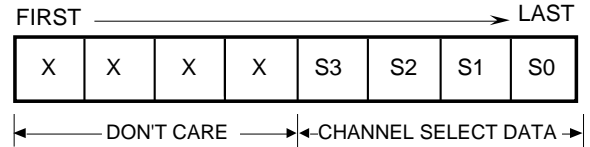

•DAC DATA

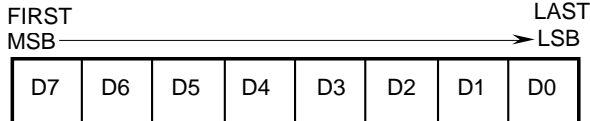

(1)CHIP SELECT DATA

MSB		LSB			
A2	A1	A0	CS2	CS1	CS0
0	0	0	0	0	0
0	0	1	0	0	1
0	1	0	0	1	0
⋮	⋮	⋮	⋮	⋮	⋮
1	1	1	1	1	1

(2)CHANNEL SELECT DATA

MSB		LSB		Channel selection
S3	S2	S1	S0	
0	0	0	0	Don't care.
0	0	0	1	ch1 selection
0	0	1	0	ch2 selection
⋮	⋮	⋮	⋮	⋮
0	1	1	1	ch11 selection
1	0	0	0	ch12 selection
1	0	0	1	Don't care.
⋮	⋮	⋮	⋮	⋮
1	1	1	1	Don't care.

(3)DAC DATA

FIRST MSB → LAST LSB

D7	D6	D5	D4	D3	D2	D1	D0	DAC output
0	0	0	0	0	0	0	0	$(V_{refU}-V_{refL})/256 \times 1 + V_{refL}$
0	0	0	0	0	0	0	1	$(V_{refU}-V_{refL})/256 \times 2 + V_{refL}$
0	0	0	0	0	0	1	0	$(V_{refU}-V_{refL})/256 \times 3 + V_{refL}$
0	0	0	0	0	0	1	1	$(V_{refU}-V_{refL})/256 \times 4 + V_{refL}$
⋮	⋮	⋮	⋮	⋮	⋮	⋮	⋮	⋮
1	1	1	1	1	1	1	0	$(V_{refU}-V_{refL})/256 \times 255 + V_{refL}$
1	1	1	1	1	1	1	1	$V_{refU}$