

RGB Video Amplifier with OSD Input Monolithic IC MM1381, 1382, 1383

February 4, 1997

Outline

MM1381XD, MM1382XD and MM1383XD are wideband RGB video amplifiers with OSD input, developed for monitors. The main differences among them are video amp bandwidth, output rise time, and output fall time.

Model	MM1381	MM1382	MM1383
Video amp band	85MHz	110MHz	140MHz
Output rise time	3.5ns	3.0ns	2.3ns
Output fall time	4.5ns	4.0ns	3.3ns

MM1382XD is described here as the representative model.

MM1382 is a wideband video amp system with OSD input, developed for high-resolution RGB monitors. MM1382 has three matched video amps with a blanking function. All DC control inputs are high impedance, and the operating range is set for easy interface with serial bus control systems, at 0~4V. The OSD block has three TTL inputs and DC contrast control. OSD signals have TTL input interface, and these signals are created internally so that OSD input low level and video black level are the same. When adjusting color balance control for video signals, OSD color balance follows the color the adjustment. In addition, MM1382 has a built-in spot-killer circuit that protects the CRT when the monitor is turned off.

Features

1. Built-in wideband video amp 110MHz @ -3dB (4V_{P-P} output)
2. OSD input has TTL interface bandwidth 50MHz
3. Output voltage less than 0.1V for blanking
4. High-speed switching between VIDEO and OSD
5. Each channel has an independent drive pin for color balance adjustment
6. Built-in high-impedance DC contrast control, 0~4V (> 40dB range)
7. Built-in high-impedance DC drive control, 0~4V (±3dB range)
8. Built-in high-impedance DC OSD contrast control, 0~4V (> 40dB range)
9. 7V_{P-P} output swing (band slightly attenuated)
10. Output can drive hybrid or discrete CRT drivers directly.

Package

DIP-28C (MM1381XD, MM1382XD, MM1383XD)

Applications

1. High-resolution RGB CRT monitors with OSD function
2. AGC amps for video
3. Wideband amps for gain and DC offset control
4. Interface amps for LCD or CCD system

Block Diagram

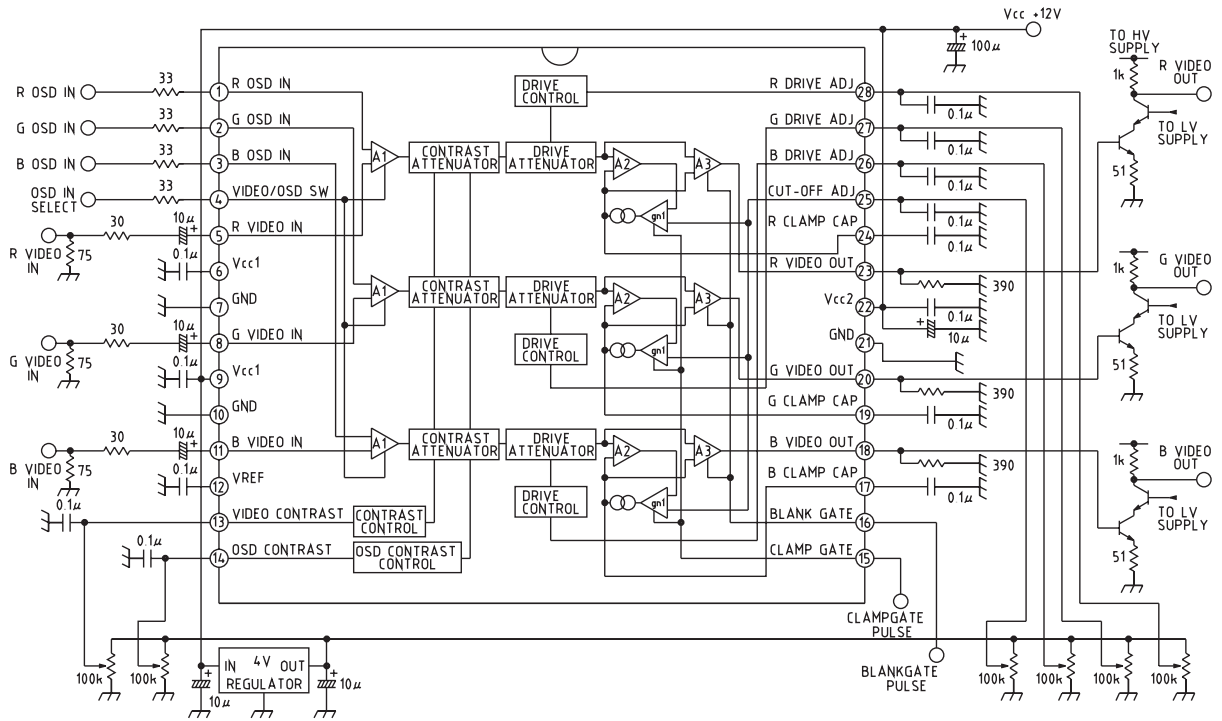

Pin Description

Pin no.	Pin name	Internal equivalent circuit diagram	Pin Description
1 2 3	R OSD IN G OSD IN B OSD IN		These inputs accept standard TTL input. Each color is either completely ON (logic high) or completely OFF (logic low). Connect unused pins to ground with a 47kΩ resistor.
4	VIDEO/OSD SWITCH		This input accepts standard TTL input. H : OSD, L : VIDEO Connect OSD to ground with a 47kΩ resistor when not in use.
5 8 11	R VIDEO IN G VIDEO IN B VIDEO IN		Video inputs. These inputs must be AC coupled using a capacitor of at least 1μF. The ideal capacitance is 10 (F. DC playback is done with these inputs. Also, serial resistor of approximately 33Ω must be used.
6 9	Vcc1		Power supply pin (except for output stage).
7 10 21	GND		GND pins. The GND pins are all connected internally, and must be connected on the board as well.
12	VREF		Used for internal reference additional filter capacitor. Voltage of this pin is 2.0V.
13 14 26 27 28	VIDEO CONTRAST OSD CONTRAST B DRIVE G DRIVE R DRIVE		Contrast control pin : 4V no attenuation 0V attenuation over 60dB Drive control pin : 4V no attenuation 0V 12dB attenuation

Pin no.	Pin name	Internal equivalent circuit diagram	Pin Description
15 16	CLAMP GATE BLANK GATE		These two pins accept TTL input and are active low. Clamp gate supplies video signal DC playback. Blank gate makes video output less than 200mV.
17 19 24	B CLAMP CAP G CLAMP CAP R CLAMP CAP		External clamp capacitors are charged, then discharged to the correction voltage required for DC playback. Recommended value is 0.1μF.
18 20 23	B VIDEO OUT G VIDEO OUT R VIDEO OUT		Video output. Output must have 390Ω impedance to obtain the correct black level.
22	Vcc2		Output stage power supply pin. Internal connection to Vcc1 does not exist.
25	RGB CUT OFF ADJUST		Sets video output black level for all three channels. Range : 0~4V Minimum value for black level is limited to approximately 300mV.

Absolute Maximum Ratings *1

Item	Symbol	Ratings	Units
Storage temperature	T _{STG}	-55~+150	°C
Power supply voltage	V _{CC} max.	15.0	V
Input voltage range	V _{IN} max.	GND ≤ V _{IN} ≤ V _{CC}	V
Video output current	I _o	28	mA
Allowable loss	P _d	2.5	W
Electrostatic breakdown		2	kV
Pin temperature		265 *16	°C

Recommended Operating Conditions *2

Item	Symbol	Ratings	Units
Operating temperature	T _{OPR}	-20~+70	°C
Operating voltage	V _{OPR}	11.4~12.6	V

DC Electrical Characteristics

(Except where noted otherwise, T_a=25°C, V_{CC1}=V_{CC2}=12V, V_{I3}=4V, V_{I4}=4V, V_{DRV}=4V, V_{CG}= 0V, V_{BG}=4V, V_{C-O}=1V) *3

Item	Symbol	Measurement conditions	Min.	Typ.	Max.	Units
Consumption current *7	V _{CC}	V _{CC1} +V _{CC2} , R _L =∞		95	120	mA
Video input resistance	R _{IN}			100		Ω
Clamp gate input voltage L	V _{CGL}		0.8	1.2		V
Clamp gate input voltage H	V _{CGH}			1.6	2.0	V
Clamp gate input current L	I _{CGL}	V _{CG} =0V		-1.5	-5.0	μA
Clamp gate input current H	I _{CGH}	V _{CG} =12V		0.01	1.0	μA
Blanking gate input voltage L	V _{BGL}		0.8	1.2		V
Blanking gate input voltage H	V _{BGH}			1.6	2.0	V
Blanking gate input current L	I _{BGL}	V _{BG} =0V		-8	-11	μA
Blanking gate input current H	I _{BGH}	V _{BG} =12V		0.01	1.0	μA
Reference voltage	V _{REF}			2.0		V
Input capacitor charging current	I _{ICL+}	V _{CG} =0V	450	750		μA
Input capacitor discharge current	I _{ICL-}	V _{CG} =0V	-450	750		μA
Input capacitor bias discharge current	I _{ICLB}	V _{CG} =4V		±750		nA
Clamp cap charging current	I _{IOCL+}	V _{CG} =0V	450	750		μA
Clamp cap discharge current	I _{IOCL-}	V _{CG} =0V	-450	-750		μA
Clamp cap bias discharge current	I _{IOCLB}	V _{CG} =4V		750		nA
Output voltage L	V _{OL}	V _{C-O} =0V		50	100	mV
Output voltage H	V _{OH}	V _{C-O} =10V	7.0	7.5		V
Black level output voltage	V _O	V _{C-O} =1V *7		1.2		V
ΔBlack level output voltage	ΔV _O	V _{C-O} =1V		±20	±250	mV
Output blanking voltage	V _{OBLK}	V _{BG} =0V		100	500	mV
Contrast/drive input current	I _{I13, 14} I _{I26~28}	V _{I3} =V _{I4} =V _{DRV} =0V~4V		-125	-500	nA
Cutoff input current	I _{C-O}	V _{□-O} =0V~4V		-1.0	-1.5	μA
Spot killer voltage	V _{SPOT}			10.6	11.2	V

AC Electrical Characteristics *14

(Except where noted otherwise, Ta=25°C, Vcc1=Vcc2=12V, V13=4V, V14=4V, VDRV=4V, VCG=0V, VBG=4V, V4=0V. For AC tests, adjust output pins 16, 20 and 23 to 4V by hand.)

Item	Symbol	Measurement conditions	Min.	Typ.	Max.	Units
Video amp gain	Av max.	V13=4V, VDRV=4V	7.5	10.0		V/V
		VIN=400mVp-p	16.9	20.0		dB
Contrast attenuation 1	ΔAv1	V13=2V		-6		dB
Contrast attenuation 2	ΔAv2	V13=0.25V		-40		dB
Drive attenuation 1	ΔAVD1	VDRV=2V		-4.5		dB
Drive attenuation 2	ΔAVD2	VDRV=0.25V		-11		dB
Gain matching	AVMAT	V13=VDRV=4V *8		±0.3		dB
Gain change between amps	ΔAVMAT	V13=4V~2V *9		±0.2		dB
Video amp distortion	THD	Vo=1Vp-p, f=10kHz		1		%
Video amp frequency bandwidth	fbw	V13=4V, VDRV=3V Vo=4Vp-p *10, 11		110		MHz
Video output rise time	tr	Vo=4Vp-p *10		3.0		ns
Video output fall time	tf	Vo=4Vp-p *10		4.0		ns
Video amp isolation 1	VSEP1	V13=4V *12		-70		dB
Video amp isolation 2	VSEP2	V13=4V *10, 12		-50		dB
Blanking output rise time	tr-BLK	Vo=1Vp-p *10		8		ns
Blanking output fall time	tf-BLK	Vo=1Vp-p *10		14		ns
Blanking rise delay time	trD-BLK	Vo=1Vp-p		23		ns
Blanking fall delay time	tfD-BLK	Vo=1Vp-p		20		ns
Back-porch clamping pulse width	tpw	*13	200			ns

OSD Electrical Characteristics

(Except where noted otherwise, Ta = 25°C, Vcc1=Vcc2=12V, V13=4V, V14=4V, VDRV=4V, VCG=4V, VBG=4V, V4=4V, Vc-o=1V)

Item	Symbol	Measurement conditions	Min.	Typ.	Max.	Units
Input voltage OSD L	VOSDL		0.4	1.2		V
Input voltage OSD H	VOSDH			1.6	2.0	V
OSD selection input voltage L	V4L		0.8	1.2		V
OSD selection input voltage H	V4H			1.6	2.0	V
OSD selection input current L	I4L	V4=0V	-3.0	-5.0		μA
OSD selection input current H	I4H	V4=12V	0.01	2.0		μA
OSD Δ black level output voltage	ΔVOUT-OSD	Vc-o=1V		±85	±175	mV
OSD output voltage VP-P	VOSD-o	V14=4V, VDRV=2V		4.5		VP-P
OSD output VP-P attenuation	ΔVOSD-o	V14=2V, VDRV=2V		50	30	%
Output adjustment between channels	VOSD-OMAT	V14=4V, VDRV=2V		±2.0		%
Output fluctuation between channels	ΔVOSD-OMAT	V14=4V~2V, VDRV=2V		±3.5		%
Video to OSD switching time	tr-OSDSW	V1=V2=V3=4V *15		4		ns
OSD-to-video switching time	tr-OSDSW	V1=V2=V3=4V *15		11		ns
Video to OSD transfer delay	trD-OSDSW	V1=V2=V3=V13=V14=4V		11		ns
OSD-to-video transport delay	tfD-OSDSW	V1=V2=V3=V13=V14=4V		12		ns
OSD rise time	tr-OSD	V14=4V		4		ns
OSD fall time	tf-OSD	V14=4V		10		ns
OSD rise delay time	trD-OSD	V14=4V		6.5		ns
OSD fall delay time	tfD-OSD	V14=4V		9		ns
Video isolation rate to OSD1	Vfeed1	V14=4V, V1=V2=V3=0V		-70		dB
Video isolation rate to OSD2	Vfeed2	V14=4V, V1=V2=V3=0V		-60		dB

Notes :

- *1 Absolute maximum ratings are the limits over which the device may be damaged.
- *2 Operating ratings are the conditions for device functioning, but they do not guarantee a specific performance limit. Refer to the electrical characteristics section for guaranteed specifications and measuring conditions. Guaranteed specifications apply only to the listed conditions. If the device does not operate within the listed measuring conditions, there may be deterioration depending on the performance characteristics.
- *3 V_{CC} supply pins 6, 9 and 22 must be connected as one externally in order to prevent internal damage during the V_{CC} power supply on/switching cycle.
- *4 Human model. Discharge via 1.5k Ω from 100pF capacitor.
- *5 The typical specified value is +25°C, indicating the standard value of the most general parameter.
- *6 The specified supply current is V_{CC1} and V_{CC2} 0 input current for R_L =[symbol]. Please refer to the measuring circuit. V_{CC2} supply current also depends on output load. V_{CC2} load current is 8mA in the measuring circuit for video output of 1V DC.
- *7 Output voltage depends on the load resistor. The measuring circuit uses $R_L=390\Omega$.
- *8 Measure the gain difference between two amps. $V_{in}=400mV_{P-P}$.
- *9 Measure A_v max. attenuation, and measure the quantitative difference between any two amps.
- *10 Special test device on GND sealed PCB not requiring a socket.
- *11 Adjust input frequency from 10MHz (A_v max. reference value) to -3dB corner frequency.
- *12 Measure the output level of two non-operational amps relative to the operating amp to check channel separation.
- *13 200ns minimum pulse width is guaranteed to 15kHz horizontal line. This limit is guaranteed at the design stage. When using a slower line speed, a clamp pulse with longer pulse width is required.
- *14 4V DC level is the AC output signal center voltage for AC testing. For example, when output is $4V_{P-P}$, the signal fluctuates between 2V DC and 6V DC.
- *15 $t_{rosd}=11ns$ and $t_{fosd}=4ns$ for $V_1=V_2=V_4=0V$ and video input of 0.7V. The video output waveform is the waveform shown in the timing diagram, inverted. Therefore, T_{rosd} is actually rise time, and T_{fosd} is actually fall time in this situation.
- *16 Solder for 10s.

Timing Diagram

Blanking transmission delay and Rise/fall time

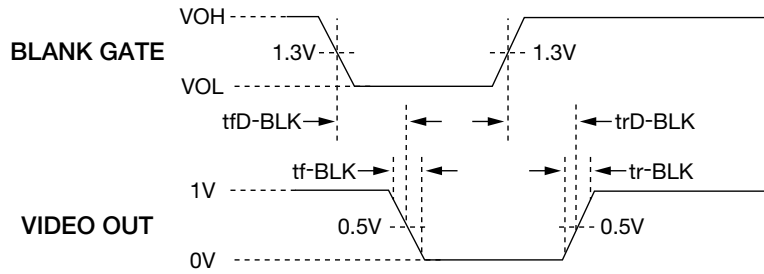

Video → OSD, OSD → Video transmission delay and Switching time

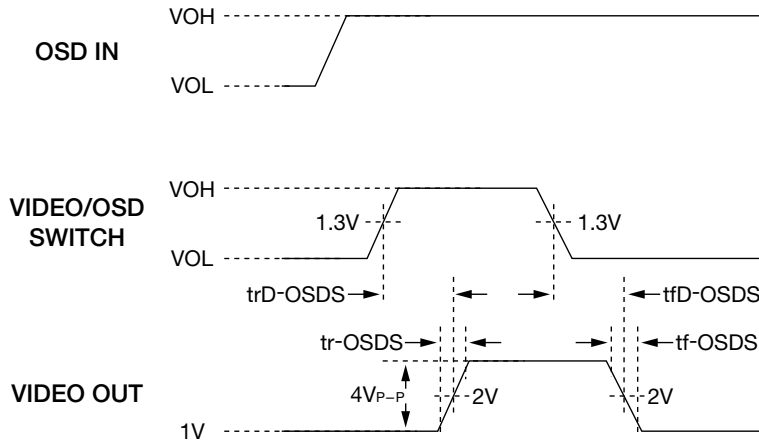

OSD transmission delay and Rise/fall time

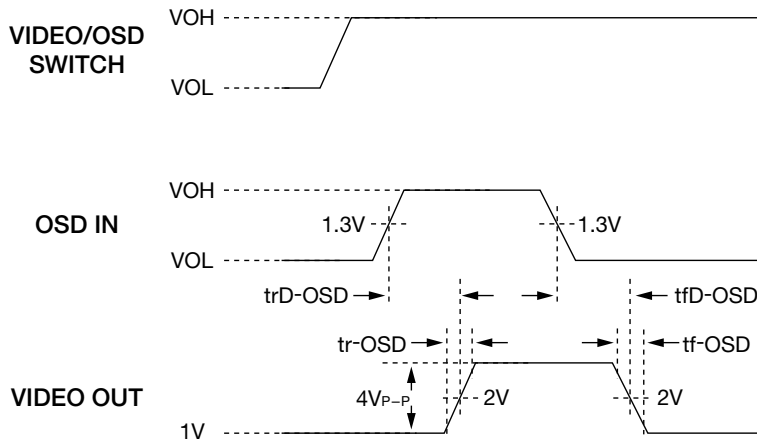

Measuring Circuit

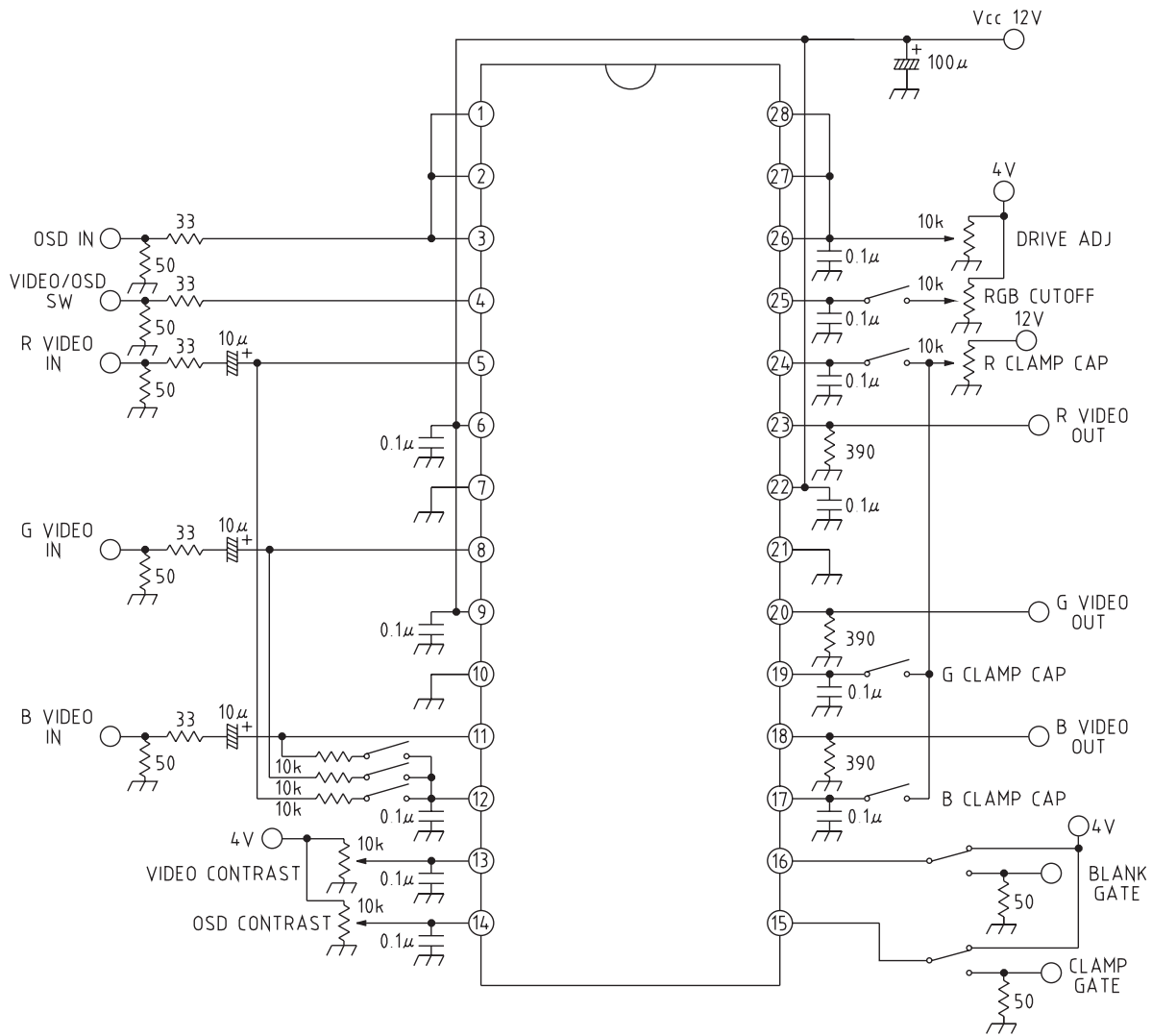

Application Circuits

