

# SP - 45ML

The SP - 45ML, a silicon photodiode mounted in a TO - 5 type header with clear epoxy encapsulation, provides wide angular response and high - output power.

**FEATURES**

- High - output power
- Relatively low - cost against metal can package
- Wide angular response

**APPLICATIONS**

- Optical detectors
- Infrared sensors
- Smoke detectors

**DIMENSIONS**

(Unit : mm)

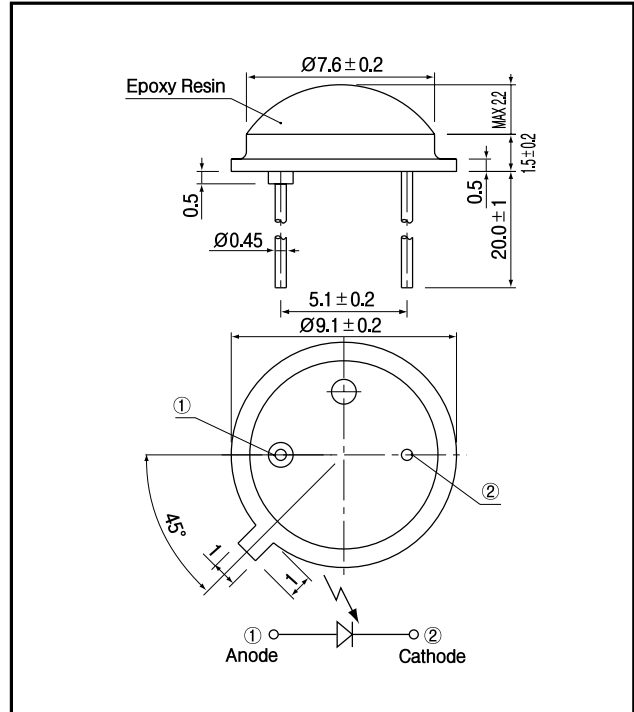

**MAXIMUM RATINGS**

(Ta=25 °C)

Item	Symbol	Rating	Unit
Reverse voltage	$V_R$	5	V
Operating temp.	Topr.	- 20 ~ + 90	
Storage temp.	Tstg.	- 30 ~ + 100	
Soldering temp. *1	Tsol.	260	

\*1. For MAX.5 seconds at the position of 2 mm from the package

**ELECTRO-OPTICAL CHARACTERISTICS**

(Ta=25 °C)

Item	Symbol	Conditions	Min.	Typ.	Max.	Unit.
Open circuit voltage	$V_{oc}$	$E_v = 1,000lx^{-2}$		0.4		V
Short circuit current	$I_{sc}$		81	170		$\mu A$
Dark current	$I_d$	$V_R = 5V$			10	$\mu A$
Curve factor	C.F.		0.55			-
Capacitance	$C_t$	$V = 0V, f = 1MHz$		1,050		pF
Temperature coefficient of $V_{oc}$	t			- 2.2		mV/
Temperature coefficient of $I_{sc}$	t			0.18		%/
Spectral sensitivity				450 ~ 1,050		nm
Peak wavelength	$\lambda_p$			900		nm
Half angle				$\pm 60$		deg.

\*2. Color temp. = 2856K standard Tungsten lamp

Photo diodes

SP - 45ML

**Light current Vs. Forward voltage**

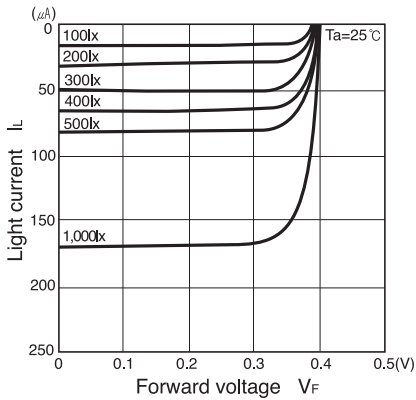

**Short circuit current Vs. Illuminance**

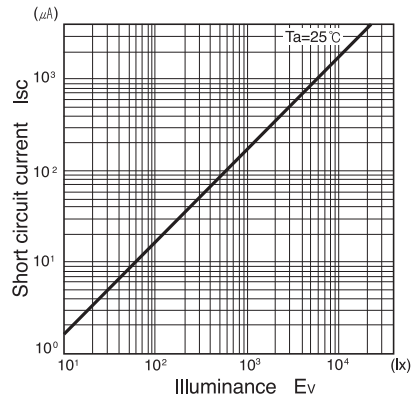

**Dark current Vs. Ambient temperature**

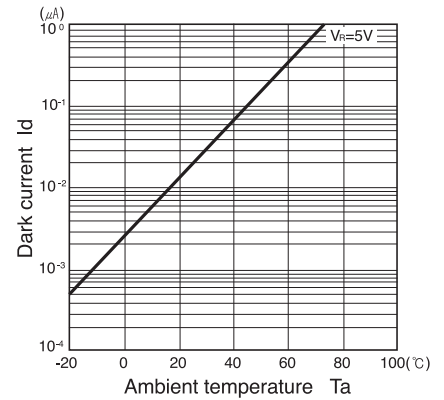

**Relative sensitivity Vs. Wavelength**

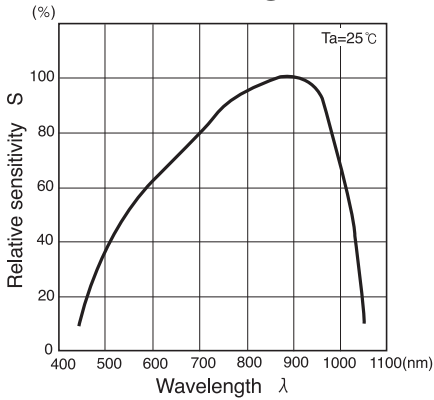

**Dark current Vs. Reverse voltage**

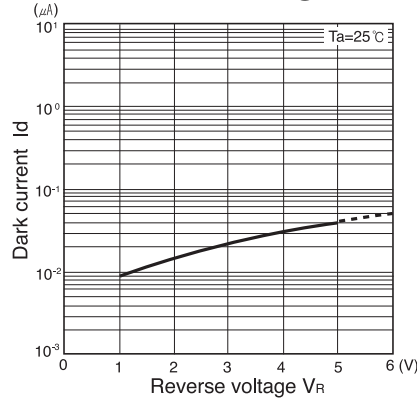

**Radiant Pattern**

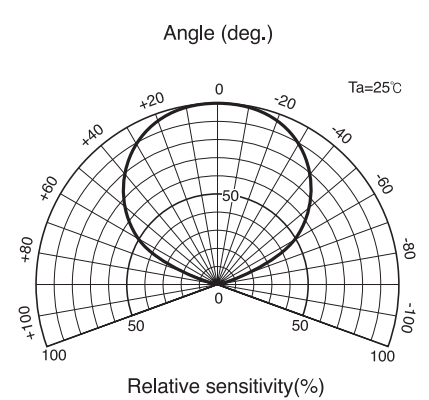

**Capacitance between terminals Vs. Reverse voltage**

