

# High Efficiency, Low Supply Current, Step-up DC/DC Converter

## General Description

The RT9262/A is a compact, high efficient, step-up DC/DC converter with an adaptive current mode PWM control loop, providing a stable and high efficient operation over a wide range of load currents. It operates in both continuous and discontinuous current modes in stable waveforms without external compensation.

The low start-up input voltage below 1V makes RT9262/A suitable for 1 to 4 battery cell applications providing up to 400mA output current. The 550KHz high switching rate minimized the size of external components. Besides, the 17 $\mu$ A low quiescent current together with high efficiency maintains long battery lifetime.

The 1.8V to 5V output voltage is set with 2 external resistors. Both internal 2A switch and driver for driving external power devices (NMOS or NPN) are provided.

A 300mA LDO is included in RT9262 to provide a secondary low noise output as well as an output current stop in the shutdown mode. Similarly, a 1.8V to 5V LDO output voltage can be set with 2 external resistors. For RT9262A, a low battery detector with 0.86V detection voltage is included. RT9262/A are provided in SOP-8 packages.

## Ordering Information

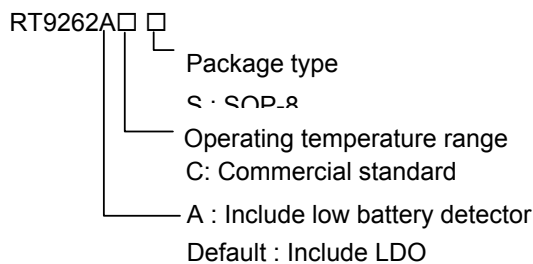

## Features

- 1.0V Low Start-up Input Voltage
- High Supply Capability to Deliver 3.3V 100mA with 1V Input Voltage
- 17 $\mu$ A Quiescent (Switch-off) Supply Current
- 90% Efficiency
- 550KHz Fixed Switching Rate
- Providing Flexibility for Using Internal and External Power Switches
- Built-in 300mA LDO, also for the Zero-Output-Current Shutdown Mode (RT9262)
- Boost DC-DC Integrating LDO for Up-Down Regulation (RT9262)
- Built-in 0.86V Voltage Detector (RT9262A)
- 8-Pin SOP Package

## Applications

- PDA
- Portable Instrument
- Wireless Equipment
- DSC
- LCD Back Bias Circuit
- RF-Tags

## Pin Configurations

Part Number	Pin Configurations
RT9262CS (Plastic SOP-8)	<p>TOP VIEW</p> <p>GND 1 8 CE EXT 2 7 LX LFB 3 6 VDD LDOO 4 5 FB</p>
RT9262ACS (Plastic SOP-8)	<p>TOP VIEW</p> <p>GND 1 8 CE EXT 2 7 LX LBO 3 6 VDD LBI 4 5 FB</p>

Marking Information

Part Number	Marking
RT9262CS	RT9262CS
RT9262ACS	RT9262ACS

Typical Application Circuit

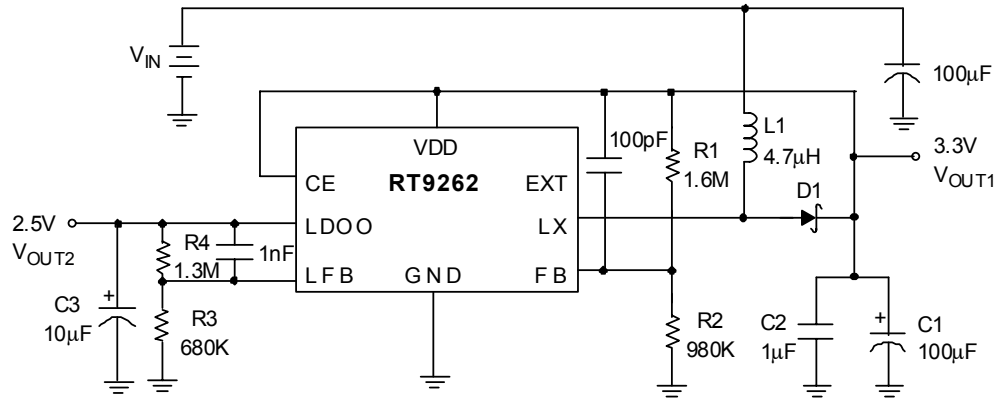

Fig. 1 RT9262 Typical Application for Portable Instruments below 400mA

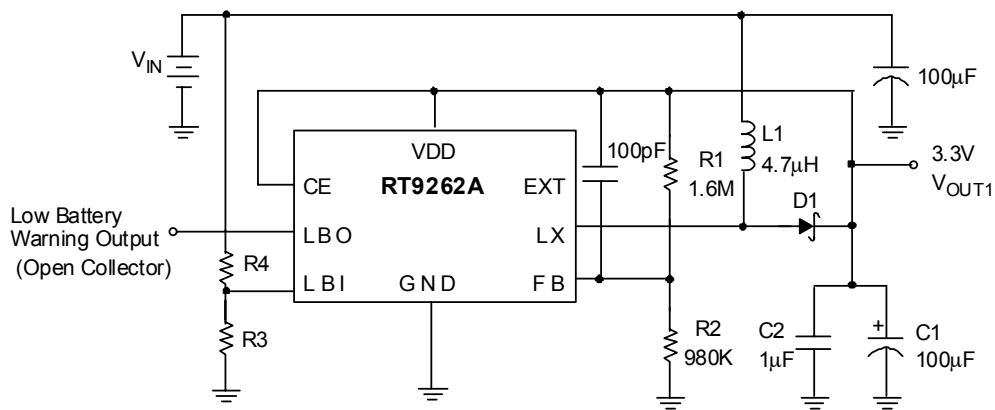

Fig. 2 RT9262A Typical Application for Portable Instruments below 400mA

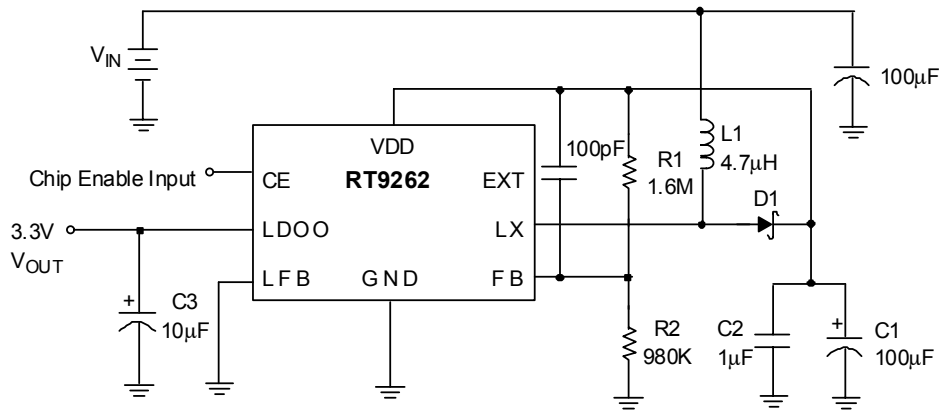

Fig. 3 Application Circuit with Zero-Output-Current Shutdown Mode Control

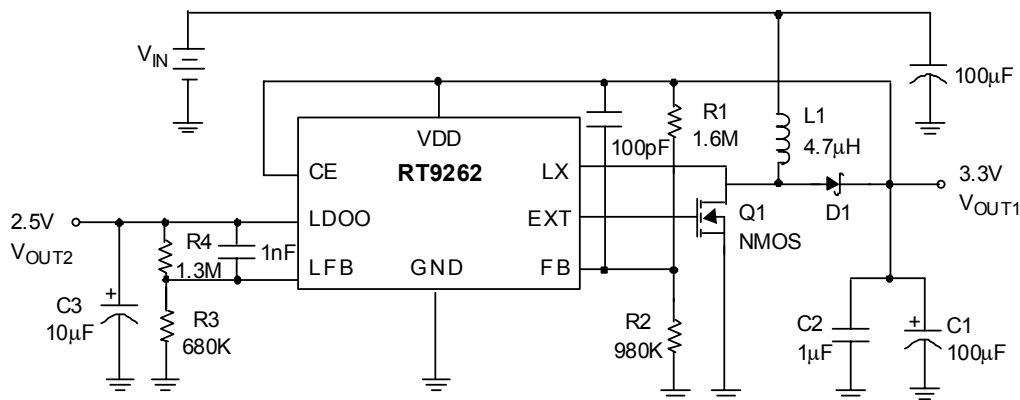

Fig. 4 0.4A ~ 2A Output Current Application

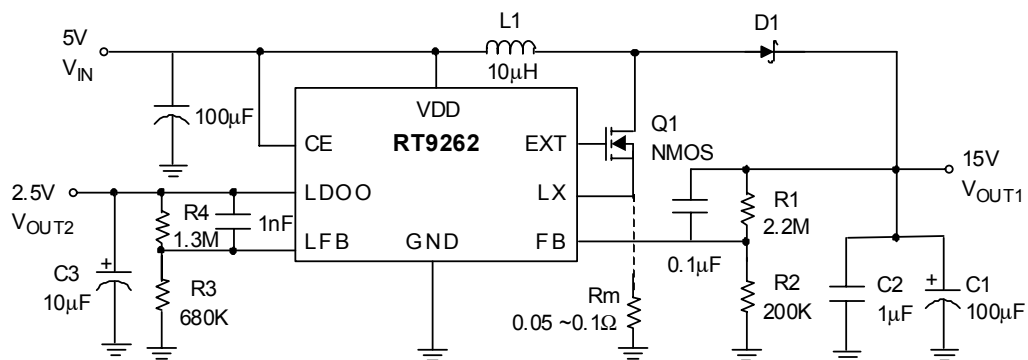

Fig. 5 High Voltage Application ( $R_m$  should be added when  $I_L > 100mA$ )

## Pin Description

Pin No.		Pin Name	Pin Function
RT9262	RT9262A		
1	1	GND	Ground
2	2	EXT	Output pin for driving external NMOS or NPN When driving an NPN, a resistor should be added for limiting base current.
3	--	LFB	Feedback pin of the built-in LDO (Internal Vref = 0.86V)
4	--	LDOO	Voltage output pin of the built-in LDO
--	3	LBO	Drain output pin of the NMOS of the built-in low voltage detector This pin will be internally pulled low when the voltage at LBI pin drops to below 0.86V.
--	4	LBI	Input pin of the built-in low voltage detector Trip point = 0.86V
5	5	FB	Feedback input pin Internal reference voltage for the error amplifier is 1.25V.
6	6	VDD	Input positive power pin of RT9262/A
7	7	LX	Pin for switching
8	8	CE	Chip enable RT9262/A gets into shutdown mode when CE pin set to low.

## Absolute Maximum Ratings

- Supply Voltage..... -0.3V to 7V
- LX Pin Switch Voltage ..... -0.3V to 7V
- LDO Output Voltage..... -0.3V to (VDD + 0.3V)
- Other I/O Pin Voltages ..... -0.3V to (VDD + 0.3V)
- LX Pin Switch Current ..... 2.5A
- EXT Pin Driver Current ..... 30mA
- LBO Current ..... 30mA
- Power Dissipation, P<sub>D</sub> @ T<sub>A</sub> = 25°C  
SOP-8 ..... 0.625W
- Package Thermal Resistance  
SOP-8, θ<sub>JA</sub> ..... 160°C/W
- Operating Junction Temperature..... 150°C
- Storage Temperature Range..... -65°C ~ +150°C

**Electrical Characteristics**

 ( $V_{IN} = 1.5V$ ,  $V_{DD}$  set to  $3.3V$ , Load Current = 0,  $T_A = 25^\circ C$ , unless otherwise specified)

Parameter	Symbol	Test Conditions	Min	Typ	Max	Units
Start-UP Voltage	$V_{ST}$	$I_L = 1mA$	--	0.98	1.05	V
Operating VDD Range	$V_{DD}$	Start-up to $I_{DD1} > 250\mu A$	0.8	--	6.5*	V
No Load Current I ( $V_{IN}$ )	$I_{NO\ LOAD}$	$V_{IN} = 1.5V$ , $V_{OUT} = 3.3V$	--	47	--	$\mu A$
Switch-off Current I (VDD)	$I_{SWITCH\ OFF}$	$V_{IN} = 6V$	--	17	--	$\mu A$
Shutdown Current I ( $V_{IN}$ )	$I_{OFF}$	CE Pin = 0V, $V_{IN} = 4.5V$	--	0.1	1	$\mu A$
Feedback Reference Voltage	$V_{REF}$	Close Loop, $V_{DD} = 3.3V$	1.225	1.25	1.275	V
Feedback Reference Voltage for LDO	RT9262 $V_{REF}$	Close Loop, $V_{DD} = 3.3V$	0.843	0.86	0.877	V
LBI Pin Trip Point	RT9262A	$V_{DD} = 3.3V$	0.843	0.86	0.877	V
Switching Rate	$F_S$	$V_{DD} = 3.3V$	--	550	--	KHz
Maximum Duty	$D_{MAX}$	$V_{DD} = 3.3V$	--	92	--	%
LX ON Resistance		$V_{DD} = 3.3V$	--	0.25	--	$\Omega$
Current Limit Setting	$I_{LIMIT}$	$V_{DD} = 3.3V$	--	2	--	A
EXT ON Resistance to VDD		$V_{DD} = 3.3V$	--	40	--	$\Omega$
EXT ON Resistance to GND		$V_{DD} = 3.3V$	--	30	--	$\Omega$
Line Regulation	$\Delta V_{LINE}$	$V_{IN} = 1.5 \sim 2.5V$ , $I_L = 1mA$	--	10	--	mV/V
Load Regulation	$\Delta V_{LOAD}$	$V_{IN} = 2.5V$ , $I_L = 1 \sim 100mA$	--	0.25	--	mV/mA
LDO PMOS ON Resistance	RT9262	$V_{DD} = 3.3V$	--	1	1.5	$\Omega$
LDO Drop Out Voltage	RT9262 $V_{DROP}$	$V_{DD} = 3.3V$ , $I_L = 100mA$	--	70	--	mV
LBO ON Resistance	RT9262A	$V_{DD} = 3.3V$	--	40	--	$\Omega$
CE Pin Trip Level		$V_{DD} = 3.3V$	0.2	0.8	1.4	V
Temperature Stability for FB, LFB, LBI	$T_S$	Guaranteed by Design	--	50	--	ppm/ $^\circ C$
Thermal Shutdown	$T_{SD}$	Guaranteed by Design	--	165	--	$^\circ C$
Thermal Shutdown Hysterises	$\Delta T_{SD}$	Guaranteed by Design	--	10	--	$^\circ C$

\* Note: The CE pin shall be tied to VDD pin and inhibit to act the ON/OFF state whenever the VDD pin voltage may reach to 5.5V or above.

Function Block Diagram

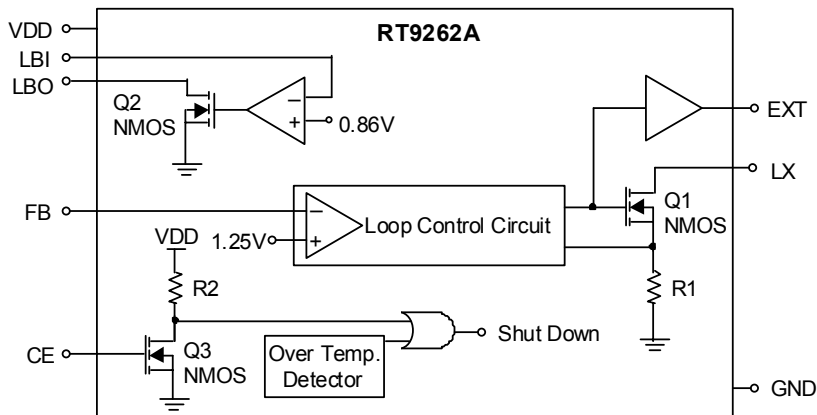
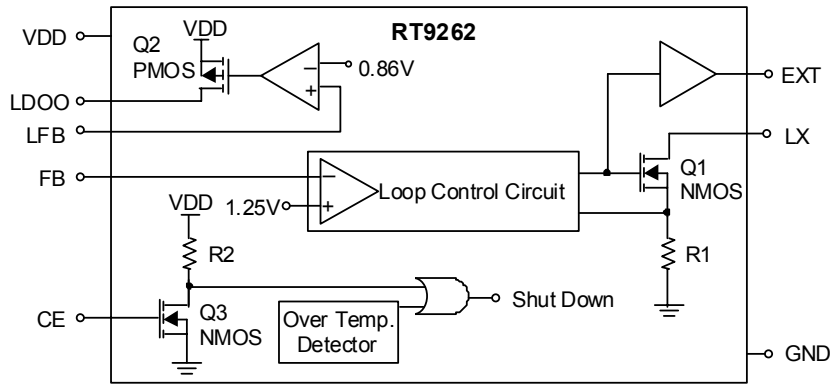

**Typical Operating Characteristics**

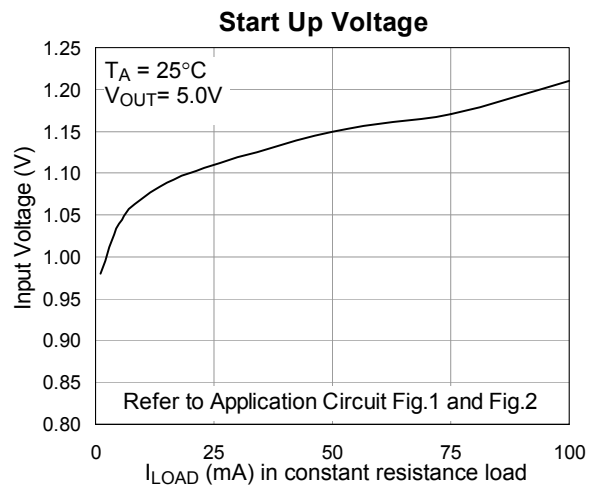
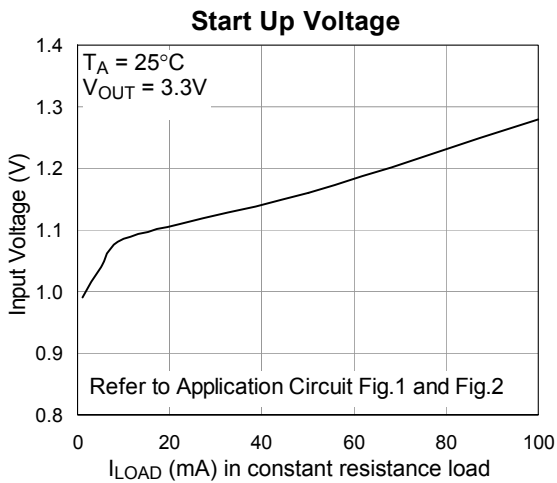
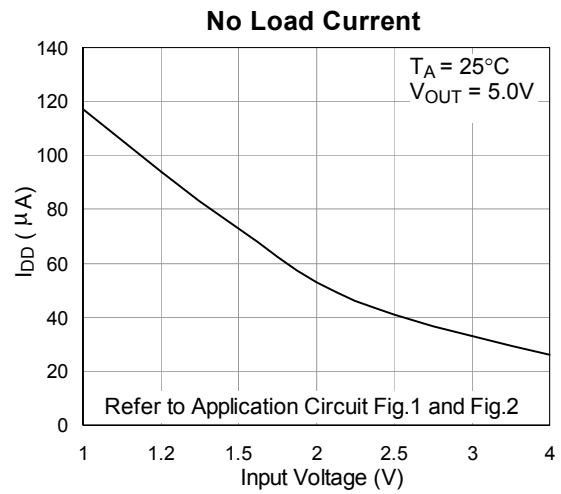
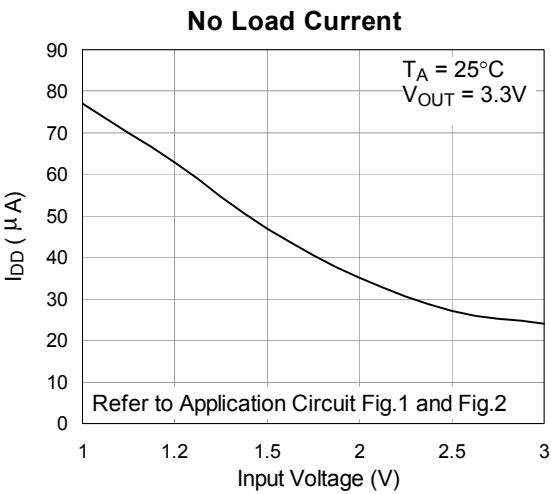
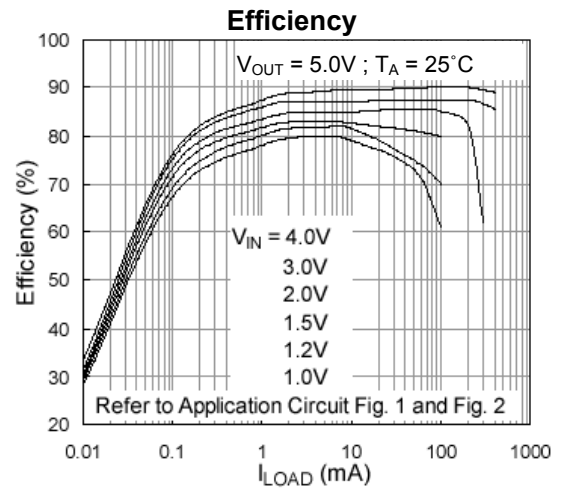
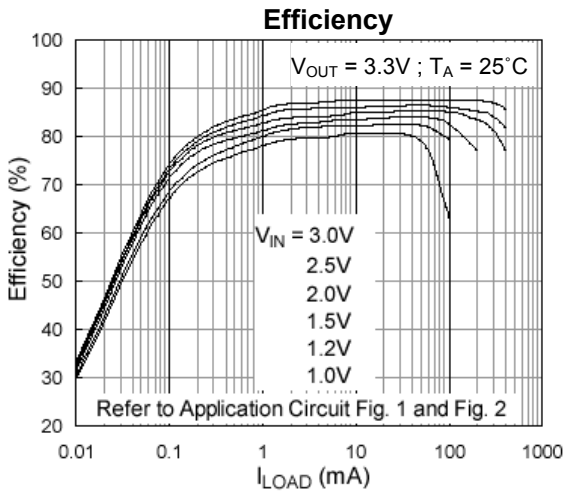

## Application Note

### Output Voltage Setting

Referring to application circuits Fig.1 to Fig.5, the output voltage of the switching regulator ( $V_{OUT1}$ ) can be set with Eq.1.

The LDO output voltage ( $V_{OUT2}$  of RT9262) can be set with Eq.2.

$$V_{OUT1} = \left(1 + \frac{R1}{R2}\right) \times 1.25V \quad \text{Eq.1}$$

$$V_{OUT2} = \left(1 + \frac{R4}{R3}\right) \times 0.86V \quad \text{Eq.2}$$

And trip point of the low battery detector is 0.86V at LBI pin of RT9262A.

### Feedback Loop Design

Referring to application circuits Fig.1 to Fig.5, The selection of R1, R2, R3, and R4 based on the trade-off between quiescent current consumption and interference immunity is stated below:

- Follow Eq.1 and Eq.2.
- Higher R reduces the quiescent current (Path current =  $1.25V/R2$ , and  $0.86V/R3$ ), however resistors beyond  $5M\Omega$  are not recommended.
- Lower R gives better noise immunity, and is less sensitive to interference, layout parasitics, FB/LFB node leakage, and improper probing to FB/LFB pins.
- A proper value of feed forward capacitor parallel with R1 (or R4) on Fig.1 to Fig.5 can improve the noise immunity of the feedback loops, especially in an improper layout. An empirical suggestion is around  $100pF \sim 1nF$  for feedback resistors of  $M\Omega$ , and  $10nF \sim 0.1\mu F$  for feedback resistors of tens to hundreds  $K\Omega$ .

For applications without standby or suspend modes, lower values of R1 to R4 are preferred. For applications concerning the current consumption in standby or suspend modes, the higher values of R1 to R4 are needed. Such “high impedance feedback loops” are sensitive to any interference, which require careful layout and avoid any interference, e.g. probing to FB/LFB pins.

**PRECAUTION 1:** Improper probing to FB or LFB pin will cause fluctuation at  $V_{OUT1}$  and  $V_{OUT2}$ . It may damage RT9262/A and system chips because  $V_{OUT1}$  may drastically rise to an over-rated level due to unexpected interference or parasitics being added to FB pin.

**PRECAUTION 2:** Disconnecting R1 or short circuit across R2 may also cause similar IC damage as described in precaution 1.

**PRECAUTION 3:** When large R values were used in feedback loops, any leakage in FB/LFB node may also cause  $V_{OUT1}$  and  $V_{OUT2}$  voltage fluctuation, and IC damage. To be especially highlight here is when the air moisture frozen and re-melt on the circuit board may cause several  $\mu A$  leakage between IC or component pins. So, when large R values are used in feedback loops, post coating, or some other moisture-preventing processes are recommended.

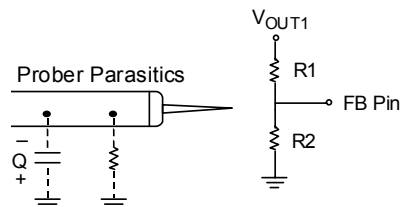

### Layout Guide

- A full GND plane without gap break.
- $V_{OUT1}$  to GND noise bypass – Short and wide connection for C2 to Pin1 and Pin6.
- $V_{IN}$  to GND noise bypass – Add a  $100\mu F$  capacitor close to L1 inductor, when  $V_{IN}$  is not an idea voltage source.
- Minimized FB/LFB node copper area and keep far away from noise sources.
- Minimized parasitic capacitance connecting to LX and EXT nodes, which may cause additional switching loss.
- The following diagram is an example of 2-layer board layout for application circuits Fig.1 to Fig.4.



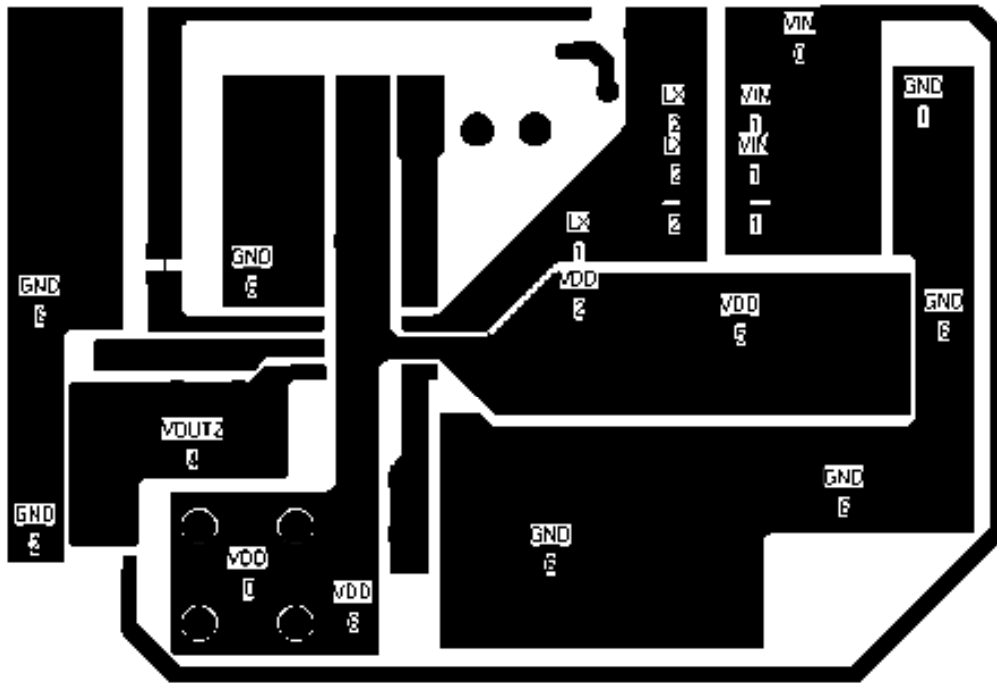

First Layer

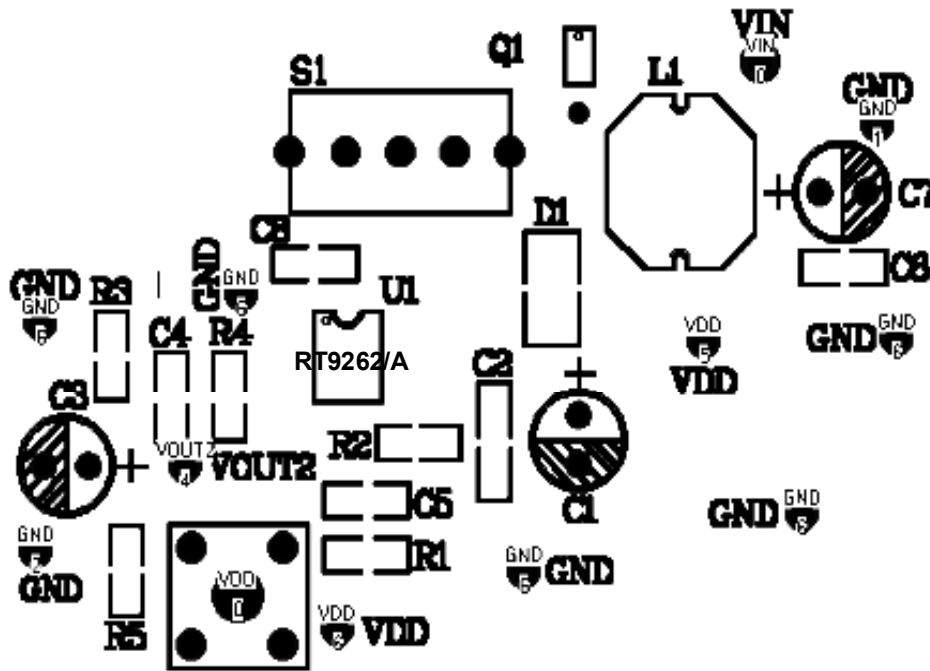

Second Layer (Full GND Plane)

Package Information

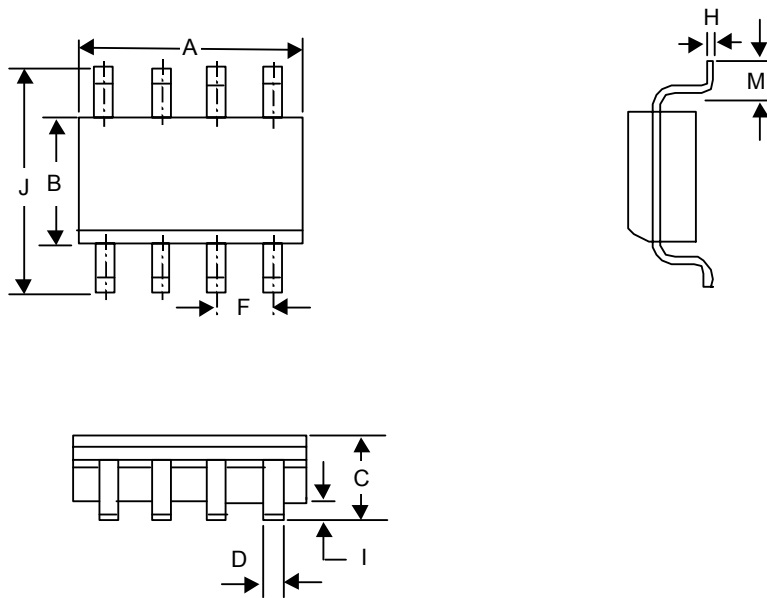

Symbol	Dimensions In Millimeters		Dimensions In Inches	
	Min	Max	Min	Max
A	4.801	5.004	0.189	0.197
B	3.810	3.988	0.150	0.157
C	1.346	1.753	0.053	0.069
D	0.330	0.508	0.013	0.020
F	1.194	1.346	0.047	0.053
H	0.178	0.254	0.007	0.010
I	0.102	0.254	0.004	0.010
J	5.791	6.198	0.228	0.244
M	0.406	1.270	0.016	0.050

8-Lead SOP Plastic Package



**RICHTEK TECHNOLOGY CORP.**

Headquarter

5F, No. 20, Taiyuen Street, Chupei City  
Hsinchu, Taiwan, R.O.C.

Tel: (8863)5526789 Fax: (8863)5526611

**RICHTEK TECHNOLOGY CORP.**

Taipei Office (Marketing)

8F-1, No. 137, Lane 235, Paochiao Road, Hsintien City  
Taipei County, Taiwan, R.O.C.

Tel: (8862)89191466 Fax: (8862)89191465

Email: [marketing@richtek.com](mailto:marketing@richtek.com)