

---

## High Performance, Triple-Output, Auto-Tracking Combo Controller

### ■ FEATURES

- Provide Triple Accurate Regulated Voltages
- Optimized Voltage-Mode PWM Control
- Dual N-Channel MOSFET Synchronous Drivers
- Fast Transient Response
- Adjustable Over Current Protection using  $R_{DS(ON)}$ . No External Current Sense Resistor Required.
- Programmable Softstart Function
- 200KHz Free-Running Oscillator
- Robust Outputs Auto-Tracking Characteristics
- Sink and Source Capabilities with External Circuit

### ■ APPLICATIONS

- Advanced PC Mboards
- Information PCs
- Servers and Workstations
- Internet Appliances
- PC Add-On Cards
- DDR Termination

### ■ GENERAL DESCRIPTION

The AIC1341 combines a synchronous voltage mode PWM controller with two linear controllers as well as the monitoring and protection functions in this chip. The PWM controller regulates the output voltage with a synchronous rectified step-down converter. The built-in N-Channel MOSFET drivers also help to simplify the design of step-down converter. It is able to power CPUs, GPUs, memories, chipsets and multi-voltage applications. The PWM controller features over current protection using  $R_{DS(ON)}$ . It improves efficiency and saves cost, as there is no expensive current sense resistor required.

Two built-in adjustable linear controllers drive an external MOSFETs to form two linear regulators that regulates power for multiple system I/O. Output voltage of both linear regulators can also be adjusted by means of the external resistor divider. Both linear regulators feature current limit. For a system I/O requires current less than 500mA, the AIC1340 is recommended for saving one external MOSFET.

The programmable soft-start design provides a controlled output voltage rise, which limits the current rate during power on time.

The shutdown function is also provided for disabling the combo controller.

## TYPICAL APPLICATION CIRCUIT

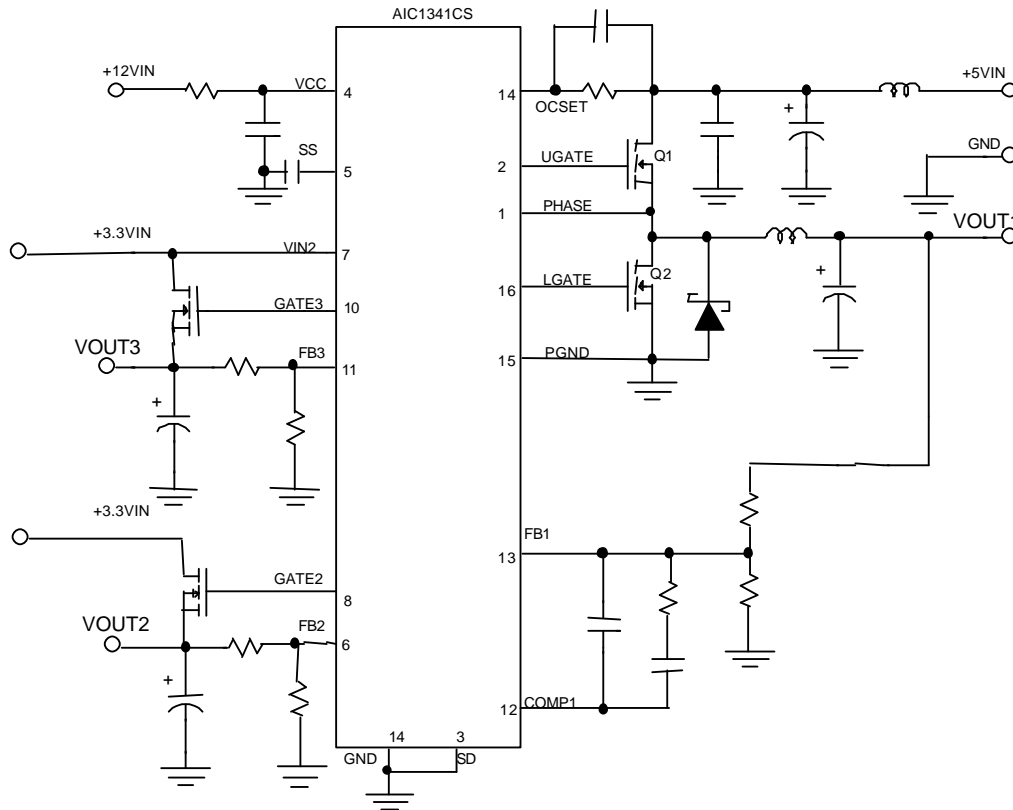

Typical Triple-Output Application

## ORDERING INFORMATION

AIC1341-XX

PACKAGING TYPE  
S: SMALL OUTLINE

TEMPERATURE RANGE  
C: 0°C~+70°C

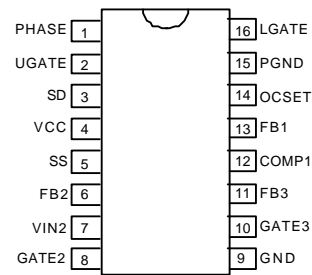
ORDER NUMBER	PIN CONFIGURATION
AIC1341CS (SO 16)	

## ■ ABSOLUTE MAXIMUM RATING

### Absolute Maximum Ratings

Supply Voltage (VCC).....	15V
UGATE.....	GND - 0.3V to $V_{CC} + 0.3V$
LGATE.....	GND - 0.3V to $V_{CC} + 0.3V$
Input Output and I/O Voltage.....	GND - 0.3V to 7V

### Operating Conditions

Ambient Temperature Range.....	0° C to 85°C
Maximum Operating Junction Temperature.....	100°C
Supply Voltage, VCC.....	15V±10%

### Thermal Information

Thermal Resistance $\theta_{JA}$ (°C/W)	
SOIC Package.....	100°C/W
Maximum Junction Temperature (Plastic Package).....	150°C
Maximum Storage Temperature Range.....	-65°C to 150°C
Maximum Lead Temperature (Soldering 10s).....	300°C

## ■ TEST CIRCUIT

Refer to APPLICATION CIRCUIT.

## ■ ELECTRICAL CHARACTERISTICS ( $V_{CC}=12V$ , $T_J=25^\circ C$ , Unless otherwise specified)

PARAMETER	TEST CONDITIONS	SYMBOL	MIN.	TYP.	MAX.	UNIT
<b>VCC SUPPLY CURRENT</b>						
Supply Current	UGATE, LGATE, GATE2 and GATE3 open	$I_{CC}$		1.8	5	mA
<b>POWER ON RESET</b>						
Rising VCC Threshold	$V_{OCSET}=4.5V$	$V_{CC_{THR}}$	8.6	9.5	10.4	V
Falling VCC Threshold	$V_{OCSET}=4.5V$	$V_{CC_{THF}}$	8.2	9.2	10.2	V
Rising VIN2 Under-Voltage Threshold		$V_{IN2_{THR}}$	2.5	2.6	2.7	V
VIN2 Under-Voltage Hysteresis		$V_{IN2_{HYS}}$		130		mV
Rising $V_{OCSET1}$ Threshold		$V_{OCSETH}$		1.3		V

**ELECTRICAL CHARACTERISTICS (Continued)**

PARAMETER	TEST CONDITIONS	SYMBOL	MIN.	TYP.	MAX.	UNIT
<b>OSCILLATOR and REFERENCE</b>						
Free Running Frequency		F	170	200	230	KHz
FB2 Reference Voltage		V <sub>REF2</sub>	1.245	1.270	1.295	V
FB3 Reference Voltage		V <sub>REF3</sub>	1.250	1.275	1.300	V
<b>LINEAR CONTROLLER</b>						
Regulation	0 < I <sub>GATE2/3</sub> < 10mA		-2.5		+2.5	%
Under-Voltage Level	FB2/3 falling	FB2/3 <sub>UV</sub>		70	80	%
<b>PWM CONTROLLER ERROR AMPLIFIER</b>						
DC GAIN				76		dB
Gain Bandwidth Product		GBWP		11		MHz
Slew Rate	COMP1=10pF	SR		6		V/μS
<b>PWM CONTROLLER GATE DRIVER</b>						
Upper Drive Source	VCC=12V, V <sub>UGATE</sub> =11V	R <sub>UGH</sub>		5.2	6.5	Ω
Upper Drive Sink	VCC=12V, V <sub>UGATE</sub> =1V	R <sub>UGL</sub>		3.3	5	Ω
Lower Drive Source	VCC=12V, V <sub>LGATE</sub> =11V	R <sub>LGH</sub>		4.1	6	Ω
Lower Drive Sink	VCC=12V, V <sub>LGATE</sub> =1V	R <sub>LGL</sub>		3	5	Ω
<b>PROTECTION</b>						
Soft-Start Current		I <sub>ss</sub>		11		μA
Chip Shutdown Soft Start Threshold					1.0	V

## PIN DESCRIPTIONS

- Pin 1: PHASE: Over-current detection pin. Connect the PHASE pin to source of the external high-side N-MOSFET. This pin detects the voltage drop across the high-side N-MOSFET  $R_{DS(ON)}$  for over-current protection.
- Pin 2: UGATE: External high-side N-MOSFET gate drive pin. Connect UGATE to gate of the external high-side N-MOSFET.
- Pin 3: SD: To shut down the system, active high or floating. If connecting a resistor to ground, keep the resistor less than 4.7K
- Pin 4: VCC: The chip power supply pin. It also provides the gate bias charge for all the MOSFETs controlled by the IC. Recommended supply voltage is 12V.
- Pin 5: SS: Soft-start pin. Connect a capacitor from this pin to ground. This capacitor, along with an internal  $10\mu\text{A}$  (typically) current source, sets the soft-start interval of the converter.  
Pulling this pin low will shut down the IC.
- Pin 6: FB2: Connect this pin to a resistor divider to set the linear regulator output voltage.
- Pin 7: VIN2: This pin supplies power to the internal regulator. Connect this pin to a suitable 3.3V source.  
Additionally, this pin is used to monitor the 3.3V supply. If, following a start-up cycle, the voltage drops below 2.6V (typically), the chip shuts down. A new soft-start cycle is initiated upon e-
- turn of the 3.3V supply above the under-voltage threshold.
- Pin 8: GATE2: Linear Controller output drive pin. This pin can drive either a Darlington NPN transistor or a N-channel MOSFET.
- Pin 9: GND: Signal GND for IC. All voltage levels are measured with respect to this pin.
- Pin 10: GATE3: Linear Controller output drive pin. This pin can drive either a Darlington NPN transistor or an N-channel MOSFET.
- Pin 11: FB3: Negative feedback pin for the linear controller error amplifier connect this pin to a resistor divider to set the linear controller output voltage.
- Pin 12: COMP1: External compensation pin. This pin is connected to error amplifier output and PWM comparator. A RC network is connected to FB1 to compensate the voltage control feedback loop of the converter.
- Pin 13: FB1: The error amplifier inverting input pin. The FB1 pin and COMP1 pin are used to compensate the voltage-control feedback loop.
- Pin 14: OCSET: Current limit sense pin. Connect a resistor  $R_{OCSET}$  from this pin to the drain of the external high-side N-MOSFET.  $R_{OCSET}$ , an internal  $200\mu\text{A}$  current source ( $I_{OCSET}$ ), and the upper N-MOSFET on-resistance ( $R_{DS(ON)}$ ) set the over-current trip point according to the following equation:
- $$I_{PEAK} = \frac{I_{OCSET} \times R_{OCSET}}{R_{DS(ON)}}$$

Pin 15: PGND: Driver power GND pin. PGND should be connected to a low impedance ground plane in close

to lower N-MOSFET source.

Pin 16: LGATE: Lower N-MOSFET gate drive pin.

## TYPICAL PERFORMANCE CHARACTERISTICS

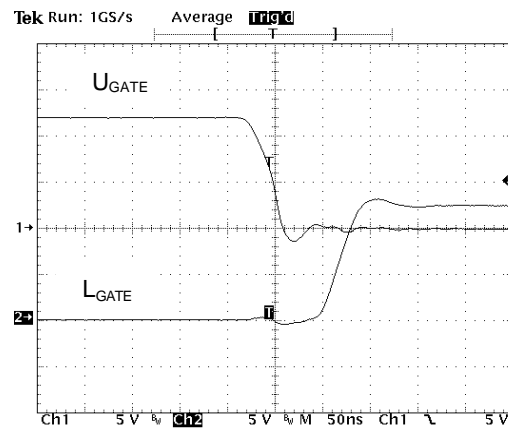
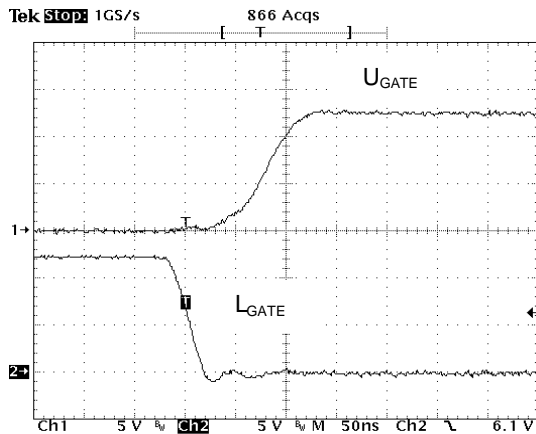

Fig.1 The gate drive waveforms

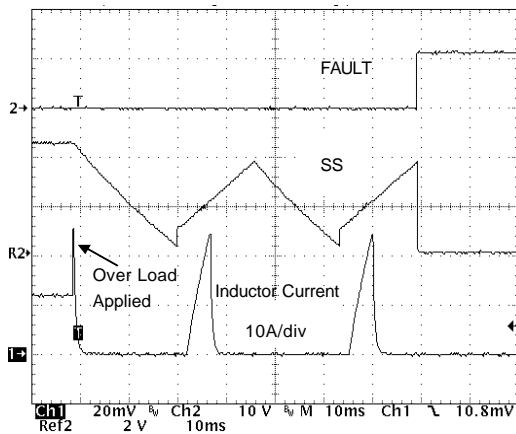

Fig.2 Over-Current Operation on Inductor

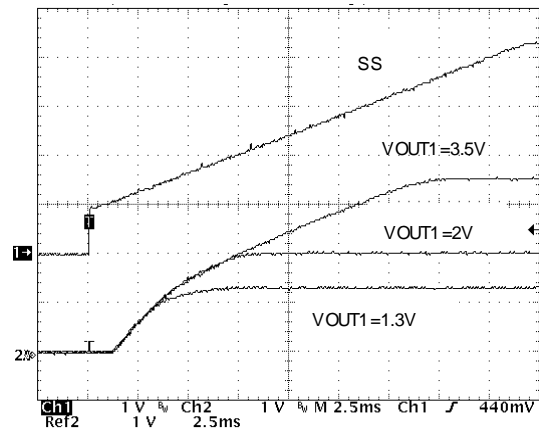

Fig.3 Soft start initiates PWM Output

**TYPICAL PERFORMANCE CHARACTERISTICS (Continued)**

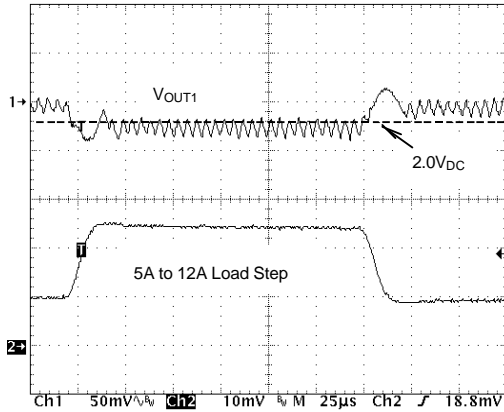

Fig.4 Transient Response of PWM Output

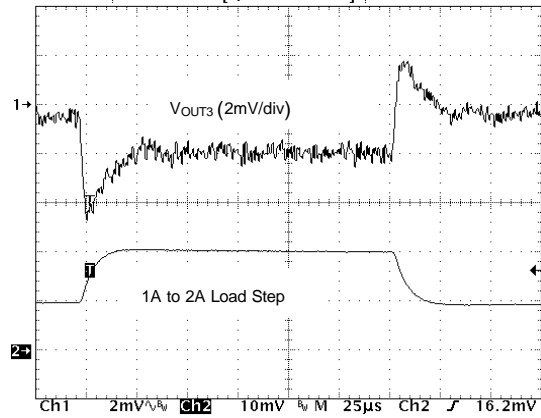
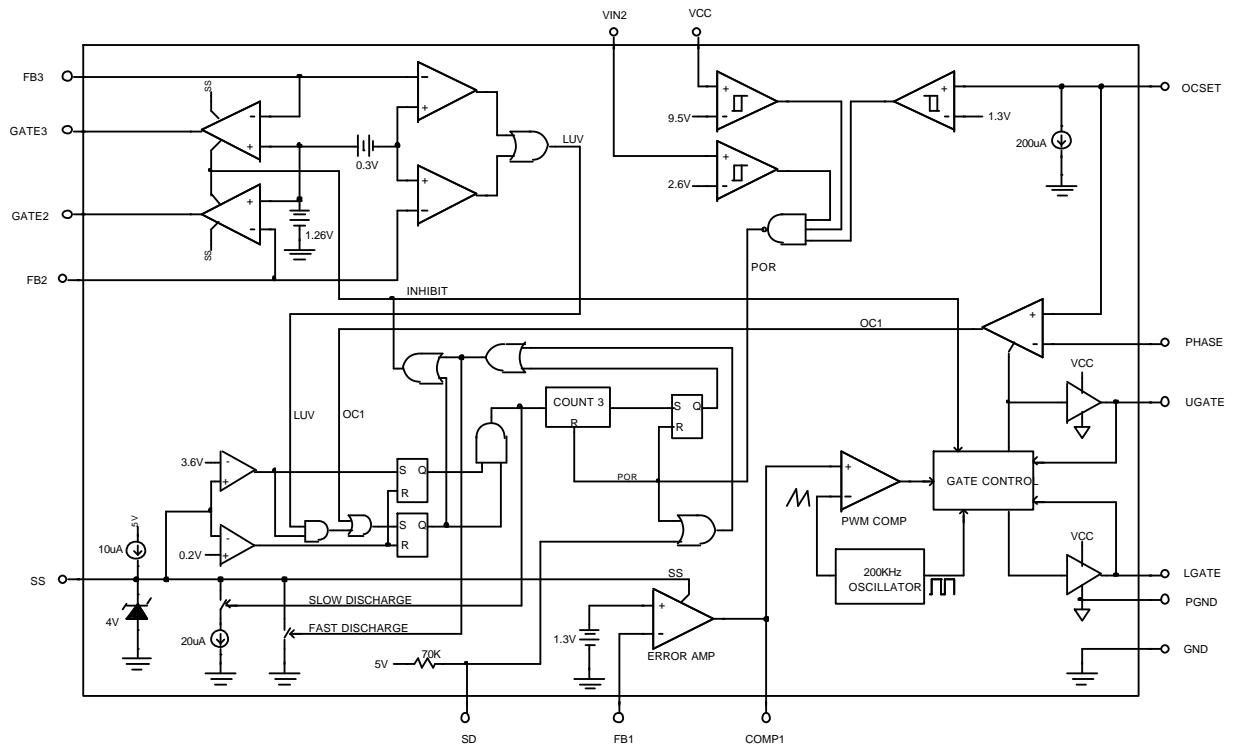

Fig.5 Transient Response of Linear Controller

**BLOCK DIAGRAM**



## DESCRIPTION

The AIC1341 is designed for applications with multiple voltage demand. This IC has one PWM controller and two linear controllers. The PWM controller is designed to regulate the voltage ( $V_{OUT1}$ ) by driving 2 MOSFETs ( $\beta$  by  $U_{GATE}$  and  $L_{GATE}$ ) in a synchronous rectified buck converter configuration. The voltage is regulated to a level, which is decided by a resistor divider network.

The Power-On Reset (POR) function continually monitors the input supply voltage +12V at VCC pin, the 5V input voltage at OCSET pin, and the 3.3V input at VIN2 pin. The POR function initiates soft-start operation after all three input supply voltage exceeds their POR thresholds.

### Soft-Start

The POR function initiates the soft-start sequence. Initially, the voltage on SS pin rapidly increases to approximate 1V. Then an internal 10 $\mu$ A current source charges an external capacitor ( $C_{SS}$ ) on the SS pin to 4V. As the SS pin voltage slews from 1V to 4V, the PWM error amplifier reference input (Non-inverting terminal) and output (COMP1 pin) is clamped to a level proportional to the SS pin voltage. As the SS pin voltage slews from 1V to 4V, the output clamp generates PHASE pulses of increasing width that charge the output capacitors. Additionally both linear regulator's reference inputs are clamped to a voltage proportional to the SS pin voltage. This method provides a controlled output voltage smooth rise.

Fig.3 shows the soft-start sequence for the typical application. The internal oscillator's triangular waveform is compared to the clamped error amplifier output voltage. As the SS pin voltage increases, the pulse width on PHASE pin increases. The interval of increasing pulse width continues until output reaches sufficient voltage to transfer control to the input reference clamp.

Each linear output ( $V_{OUT2}$  and  $V_{OUT3}$ ) initially follows a ramp. When each output reaches suffi-

cient voltage the input reference clamp slows the rate of output voltage rise.

### Over-Current Protection

All outputs are protected against excessive over-current. The PWM controller uses upper MOSFET's on-resistance,  $R_{DS(ON)}$  to monitor the current for protection against shorted outputs. Both the linear regulator and controller monitor FB2 and FB3 for under-voltage to protect against excessive current.

When the voltage across Q1 ( $I_D R_{DS(ON)}$ ) exceeds the level ( $200\mu A R_{OCSET}$ ), this signal inhibit all outputs. Discharge soft-start capacitor ( $C_{SS}$ ) with 10 $\mu$ A current sink, and increments the counter.  $C_{SS}$  recharges and initiates a soft-start cycle again until the counter increments to 3. This sets the fault latch to disable all outputs. Fig. 2 illustrates the over-current protection until an over load on OUT1.

Should excessive current cause FB2 or FB3 to fall below the linear under-voltage threshold, the LUV signal sets the over-current latch if  $C_{SS}$  is fully charged. Cycling the bias input power off then on reset the counter and the fault latch.

The over-current function for PWM controller will trip at a peak inductor current ( $I_{PEAK}$ ) determined by:

$$I_{PEAK} = \frac{I_{OCSET} \times R_{OCSET}}{R_{DS(ON)}}$$

The OC trip point varies with MOSFET's temperature. To avoid over-current tripping in the normal operating load range, determine the  $R_{OCSET}$  resistor from the equation above with:

1. The maximum  $R_{DS(ON)}$  at the highest junction.
2. The minimum  $I_{OCSET}$  from the specification table.
3. Determine  $I_{PEAK} > I_{OUT(MAX)} + (\text{inductor ripple current}) / 2$ .



## Shutdown

Compatible with the TTL logic level, by holding the SD (pin3) pin low will activate the controller. If connecting a resistor to ground, make sure the resistor is less than 4.7KΩ for normal operation.

## Layout Considerations

Any inductance in the switched current path generates a large voltage spike during the switching interval. The voltage spikes can degrade efficiency, radiate noise into the circuit, and lead to device over-voltage stress. Careful component selection and tight layout of critical components, and short, wide metal trace minimize the voltage spike.

- 1) A ground plane should be used. Locate the input capacitors ( $C_{IN}$ ) close to the power switches. Minimize the loop formed by  $C_{IN}$ , the upper MOSFET (Q1) and the lower MOSFET (Q2) as possible. Connections should be as wide as short as possible to minimize loop inductance.
- 2) The connection between Q1, Q2 and output inductor should be as wide as short as practical. Since this connection has fast voltage transitions will easily induce EMI.
- 3) The output capacitor ( $C_{OUT}$ ) should be located as close the load as possible. Because minimize the transient load magnitude for high slew rate requires low inductance and resistance in circuit board
- 4) The AIC1341 is best placed over a quiet ground plane area. The GND pin should be connected to the groundside of the output capacitors. Under no circumstances should GND be returned to a ground inside the  $C_{IN}$ ,

Q1, Q2 loop. The GND and PGND pins should be shorted right at the IC. This help to minimize internal ground disturbances in the IC and prevents differences in ground potential from disrupting internal circuit operation.

- 5) The wiring traces from the control IC to the MOSFET gate and source should be sized to carry 1A current. Locate  $C_{OUT2}$  close to the AIC1341 IC.
- 6) The Vcc pin should be decoupled directly to GND by a 1μF ceramic capacitor, trace lengths should be as short as possible.

A multi-layer printed circuit board is recommended. Figure 6 shows the connections of the critical components in the converter. The  $C_{IN}$  and  $C_{OUT}$  could each represent numerous physical capacitors. Dedicate one solid layer for a ground plane and make all critical component ground connections with vias to this layer.

## PWM Output Capacitors

The load transient for the microprocessor core requires high quality capacitors to supply the high slew rate (di/dt) current demand.

The ESR (equivalent series resistance) and ESL (equivalent series inductance) parameters rather than actual capacitance determine the buck capacitor values. For a given transient load magnitude, the output voltage transient change due to the output capacitor can be note by the following equation:

$$\Delta V_{OUT} = ESR \times \Delta I_{OUT} + ESL \times \frac{\Delta I_{OUT}}{\Delta T}, \quad \text{where}$$

$\Delta I_{OUT}$  is transient load current step.

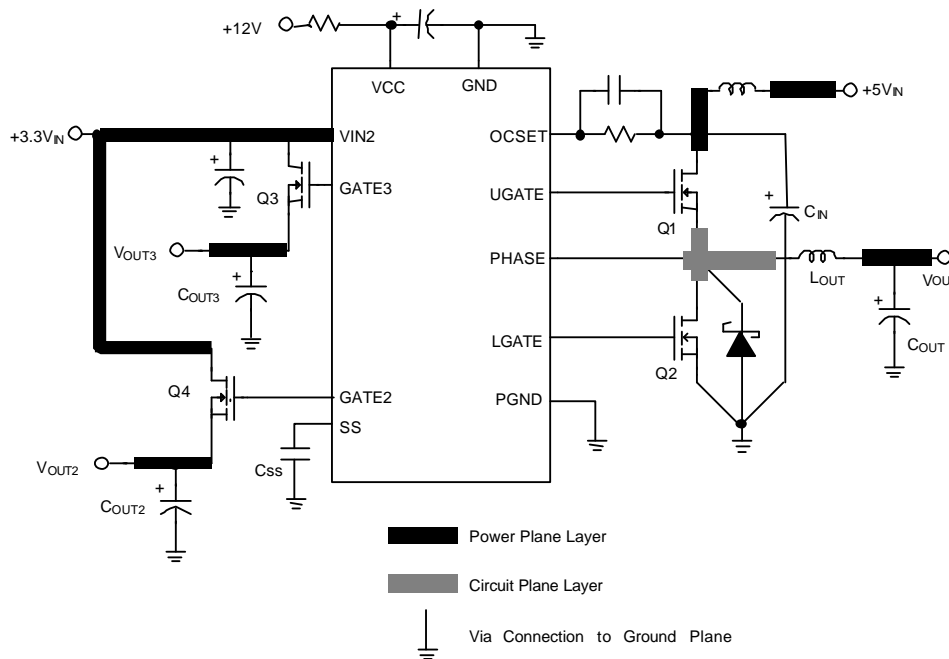

**Fig.6 Printed circuit board power planes and islands**

After the initial transient, the ESL dependent term drops off. Because the strong relationship between output capacitor ESR and output load transient, the output capacitor is usually chosen for ESR, not for capacitance value. A capacitor with suitable ESR will usually have a larger capacitance value than is needed for energy storage.

A common way to lower ESR and raise ripple current capability is to parallel several capacitors. In most case, multiple electrolytic capacitors of small case size are better than a single large case capacitor.

### Output Inductor Selection

Inductor value and type should be chosen based on output slew rate requirement, output ripple requirement and expected peak current. Inductor value is primarily controlled by the required current response time. The AIC1341 will provide either 0% or 85% duty cycle in response to a load transient.

The response time to a transient is different for the application of load and remove of load.

$$t_{RISE} = \frac{L \times \Delta I_{OUT}}{V_{IN} - V_{OUT}}, \quad t_{FALL} = \frac{L \times \Delta I_{OUT}}{V_{OUT}}$$

Where  $\Delta I_{OUT}$  is transient load current step.

In a typical 5V input, 2V output application, a 3μH inductor has a 1A/μS rise time, resulting in a 5μS delay in responding to a 5A load current step. To optimize performance, different combinations of input and output voltage and expected loads may require different inductor value. A smaller value of inductor will improve the transient response at the expense of increase output ripple voltage and inductor core saturation rating.

Peak current in the inductor will be equal to the maximum output load current plus half of inductor ripple current. The ripple current is approximately equal to:

$$I_{\text{RIPPLE}} = \frac{(V_{\text{IN}} - V_{\text{OUT}}) \times V_{\text{OUT}}}{f \times L \times V_{\text{IN}}};$$

f = 200KHz oscillator frequency.

The inductor must be able to withstand peak current without saturation, and the copper resistance in the winding should be kept as low as possible to minimize resistive power loss

### Input Capacitor Selection

Most of the input supply current is supplied by the input bypass capacitor, the resulting RMS current flow in the input capacitor will heat it up. Use a mix of input bulk capacitors to control the voltage overshoot across the upper MOSFET. The ceramic capacitance for the high frequency decoupling should be placed very close to the upper MOSFET to suppress the voltage induced in the parasitic circuit impedance. The buck capacitors to supply the RMS current is approximate equal to:

$$I_{\text{RMS}} = (1-D) \times \sqrt{D} \times \sqrt{I_{\text{OUT}}^2 + \frac{1}{12} \times \left( \frac{V_{\text{IN}} \times D}{f \times L} \right)^2}$$

, where  $D = \frac{V_{\text{OUT}}}{V_{\text{IN}}}$

The capacitor voltage rating should be at least 1.25 times greater than the maximum input voltage.

### PWM MOSFET Selection

In high current PWM application, the MOSFET power dissipation, package type and heatsink are the dominant design factors. The conduction loss is the only component of power dissipation for the lower MOSFET, since it turns on into near zero voltage. The upper MOSFET has conduction loss and switching loss. The gate charge losses are proportional to the switching frequency and are

dissipated by the AIC1341. However, the gate charge increases the switching interval,  $t_{\text{sw}}$ , which increase the upper MOSFET switching losses. Ensure that both MOSFETs are within their maximum junction temperature at high ambient temperature by calculating the temperature rise according to package thermal resistance specifications.

$$P_{\text{UPPER}} = I_{\text{OUT}}^2 \times R_{\text{DS(ON)}} \times D + \frac{I_{\text{OUT}} \times V_{\text{IN}} \times t_{\text{sw}} \times f}{2}$$

$$P_{\text{LOWER}} = I_{\text{OUT}}^2 \times R_{\text{DS(ON)}} \times (1-D)$$

The equations above do not model power loss due to the reverse recovery of the lower MOSFET's body diode.

The  $R_{\text{DS(ON)}}$  is different for the two previous equations even if the type devices is used for both. This is because the gate drive applied to the upper MOSFET is different than the lower MOSFET. Logic level MOSFETs should be selected based on on-resistance considerations,  $R_{\text{DS(ON)}}$  should be chosen base on input and output voltage, allowable power dissipation and maximum required output current. Power dissipation should be calculated based primarily on required efficiency or allowable thermal dissipation.

Rectifier Schottky diode is a clamp that prevent the loss parasitic MOSFET body diode from conducting during the dead time between the turn off of the lower MOSFET and the turn on of the upper MOSFET. The diode's rated reverse breakdown voltage must be greater than twice the maximum input voltage.

### Linear Controller MOSFET Selection

The power dissipated in a linear regulator is :

$$P_{\text{LINEAR}} = I_{\text{OUT}} \times (V_{\text{IN2}} - V_{\text{OUT}})$$

Select a package and heatsink that maintains junction temperature below the maximum rating

while operation at the highest expected ambient temperature.

#### **Linear Output Capacitor**

The output capacitors for the linear controller provide dynamic load current. The linear controller uses dominant pole compensation integrated in the error amplifier and is insensitive to output capacitor selection.  $C_{OUT2}$  and  $C_{OUT3}$  should be selected for transient load regulation.

#### **Notes**

$V_{OUT1}$  - The PWM output

$V_{OUT2}$  - The linear controller dominated by FB2, GATE2 and VIN2

$V_{OUT3}$  - The linear controller dominated by FB3 and GATE3

All the designators mentioned above are referring to the **TYPICAL APPLICATION CIRCUIT** in previous page.

## APPLICATION CIRCUIT

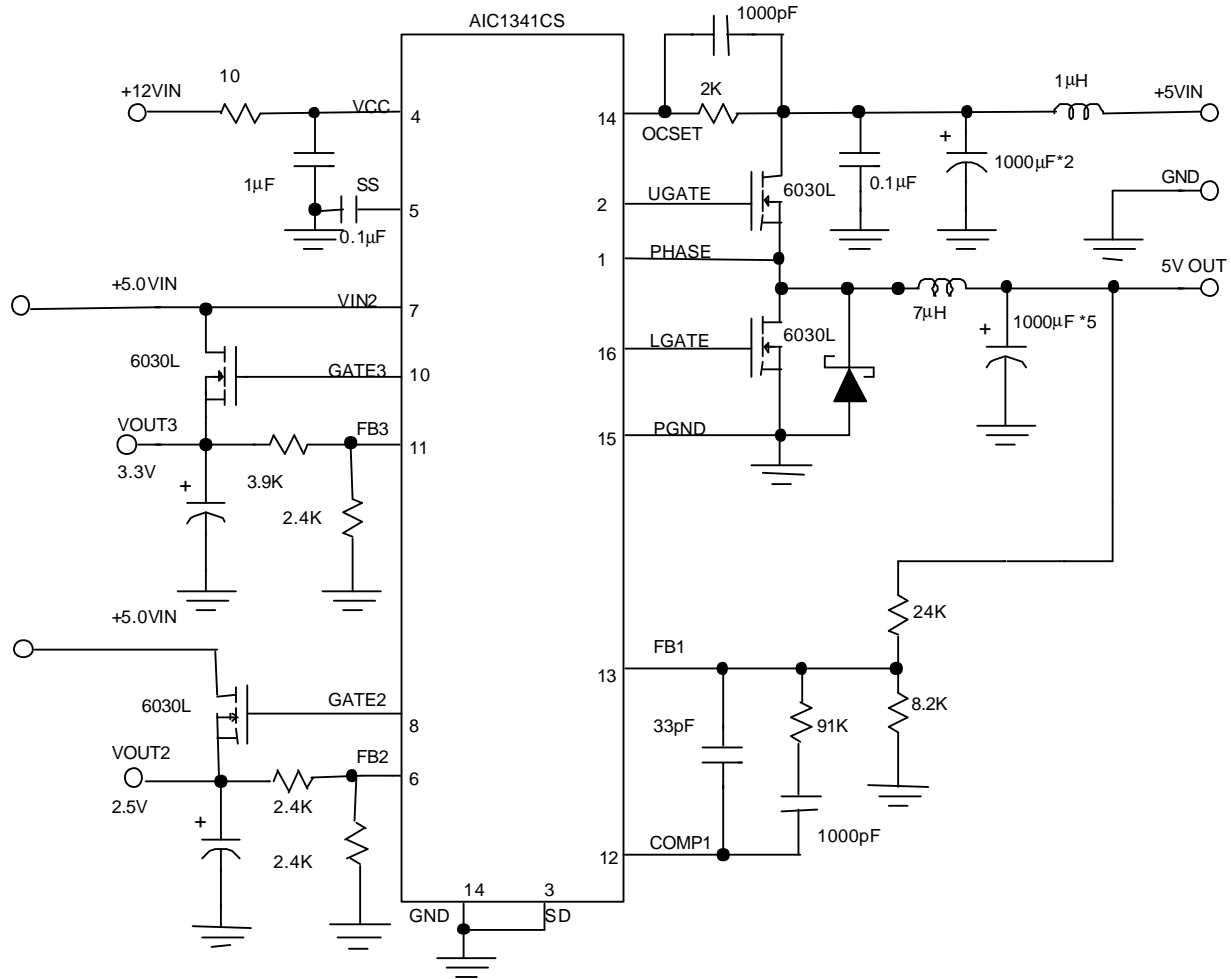

**Circuit 1 Multiple Voltage Power application Circuit**

**PACKAGE DIMENSIONS**

- 16 LEAD PLASTIC SO (300 mil) (unit: mm)

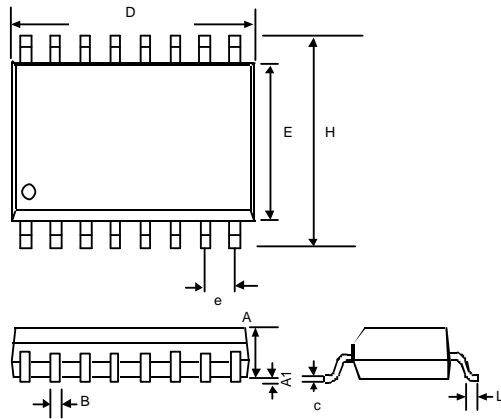

SYMBOL	MIN	MAX
A	2.35	2.65
A1	0.10	0.30
B	0.33	0.51
C	0.23	0.32
D	10.10	10.50
E	7.40	7.60
e	1.27(TYP)	
H	10.00	10.65
L	0.40	1.27