

Plug and Play VGA to NTSC / PAL Converter

Applications

- PC ready multimedia TV
- TV output for laptop, network, entertainment PC
- Net browser/set-top box
- Internet TV
- VGA add-on card with TV output
- VGA to TV converter box

Description

The AL128 PC to TV scan converter chip accepts graphic data up to 1024x768 resolution from PC and Macintosh graphics controllers and converts it into high quality NTSC or PAL TV signals. This new chip is pin-to-pin compatible with the AverLogic AL100 but provides analog RGB output for SCART implementation.

- Convert non-interlaced VGA or Macintosh video into interlaced TV format (NTSC/PAL)
- Analog RGB output for SCART interface
- Highly integrated design with built-in NTSC/PAL encoder, ADC, DAC and SRAM
- High clarity 5-line anti-flicker filter
- 8 levels of sharpness control
- Supports up to full 1024x768 VGA resolution
- Automatically supports scan rate from 50Hz up to 100Hz
- Linear vertical and horizontal over/underscan control
- Zoom and freeze controls
- Four-touch-button interface with on-screen-menu on TV
- Horizontal and vertical position/panning control
- Optional digital 24-bit RGB/VAFC interface
- Power down feature controlled by software or hardware
- Full programmability via I²C interface
- Brightness control
- Built-in color bar
- Thin, small LQFP package for PCMCIA or notebooks
- 28x28 PQFP package available upon request

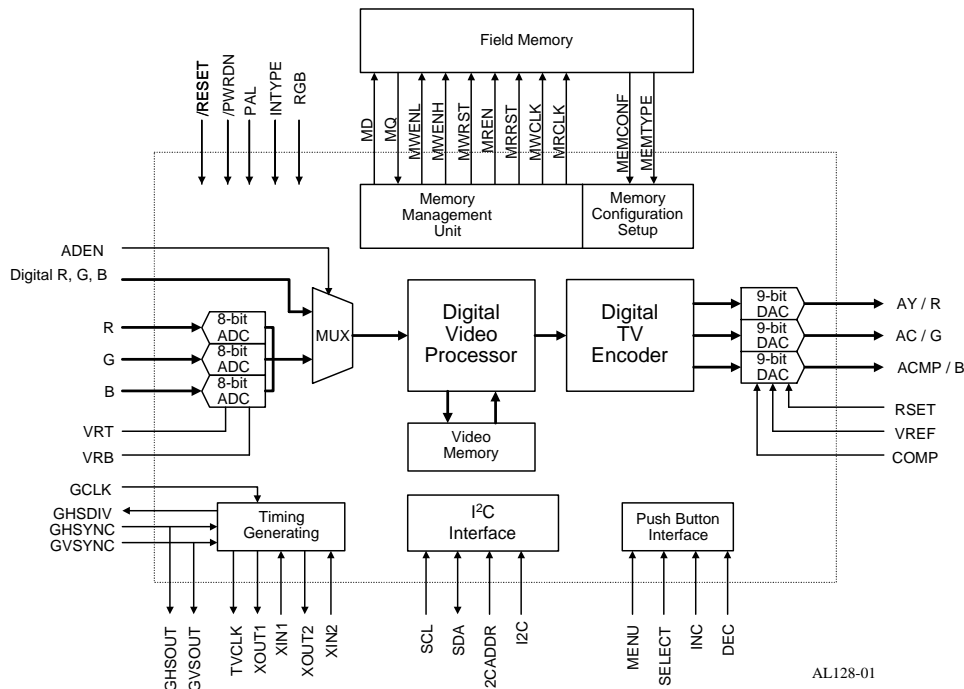

An integrated high-quality anti-flicker filter (SmartFilter™) removes the unpleasant flicker caused by the interlaced display of high contrast graphics while maintaining the original clarity and sharpness of informative data such as natural pictures and text.

With 512Kbytes of memory, plug-and-play is achieved by automatically detecting the scan rate and resolution of the incoming graphic signals without the use of software. With less memory than other solutions on the market, high resolution data is processed and stored by using a complex and proprietary buffer management system. No compromise is made at all with video quality by using either compression or sub-sampling algorithms.

The major functions of the AL128 can be accessed using four push buttons combined with the on-screen-menu feature, this eliminates the cost of a micro-controller and complex control panel. The superior quality scaling algorithm, which reduces the jagged-edge artifacts from line dropping, can smoothly fit graphics of 640x480 (up to 100 Hz) and 1024x768 (up to 75Hz) resolutions into the visible region of the NTSC or PAL screen. Both horizontal and vertical sizes can be linearly adjusted. Additional features include eight levels of flicker control using 5-line filter, zoom control and picture freeze.

This highly integrated mix-signal chip, packaged in 24mm x 24mm 160-pin LQFP (low quad flat package), is powered by a single 5-volt power supply. Power-down is achieved by using either hardware or software control.

The enhanced features and superior quality make the AL128 very suitable for PC video to TV conversion in PC ready multimedia TV's, scan converter boxes, VGA add-on cards, Web TVs, or network / laptop PCs.

Functional Description

Either analog RGB or digital RGB data can be input to the chip. The analog RGB data is digitized by three 50MHz 8-bit video A/D's and is converted into 24-bit digital RGB data. For

graphic controllers with standard or proprietary digital RGB output such as a high-color feature connector, VAFC, or flat panel interface, the optional 24-bit digital RGB interface provides a solution for optimal video quality.

The 24-bit digital RGB is passed to the digital processing unit of the chip. This DSP unit performs scan conversion operations and other digital signal processing such as flicker filtering, YUV filtering, scaling and color space conversion in the digital domain. The processed video data is sent to the digital TV encoder for converting into broadcast quality composite and S-video signals or original RGB format, which are in turn converted by three 9-bit D/A converters into analog outputs.

Functions can be controlled by dedicated hardware pins as well as software. The I²C interface provides full software programmability. The aforementioned hardware and software programmability also applies for the power-down feature. Alternatively only four push buttons are required to control the major functions such as sharpness, pan, zoom, brightness, color bar output and position centering without the use of software or microcontroller.

For more information about the AL128 or the other products from AverLogic, please contact our local representatives, visit our website, or contact us directly.

DISTRIBUTED BY:

www.averlogic.com

AVERLOGIC TECHNOLOGIES, INC. E-mail: sales_usa@averlogic.com
AVERLOGIC TECHNOLOGIES, CORP. E-mail: sales@averlogic.com.tw

URL: www.averlogic.com
URL: www.averlogic.com.tw
February 25, 2003