



**USE ULTRA3700™
FOR ALL NEW DESIGNS**

CY7C372i

UltraLogic™ 64-Macrocell Flash CPLD

Features

- 64 macrocells in four logic blocks
- 32 I/O pins
- Five dedicated inputs including two clock pins
- In-System Reprogrammable (ISR™) Flash technology
 - JTAG interface
- Bus Hold capabilities on all I/Os and dedicated inputs
- No hidden delays
- High speed
 - $f_{MAX} = 125 \text{ MHz}$
 - $t_{PD} = 10 \text{ ns}$
 - $t_S = 5.5 \text{ ns}$
 - $t_{CO} = 6.5 \text{ ns}$
- Fully PCI compliant
- 3.3V or 5.0V I/O operation
- Available in 44-pin PLCC, TQFP, and CLCC packages
- Pin-compatible with the CY7C371i

Functional Description

The CY7C372i is an In-System Reprogrammable Complex Programmable Logic Device (CPLD) and is part of the FLASH370i™ family of high-density, high-speed CPLDs. Like all members of the FLASH370i family, the CY7C372i is designed to bring the ease of use and high performance of the 22V10, as well as PCI Local Bus Specification support, to high-density CPLDs.

Like all of the UltraLogic™ FLASH370i devices, the CY7C372i is electrically erasable and ISR, which simplifies both design and manufacturing flows, thereby reducing costs. The Cypress ISR function is implemented through a JTAG serial interface. Data is shifted in and out through the SDI and SDO pins. The ISR interface is enabled using the programming voltage pin (ISR_{EN}). Additionally, because of the superior routability of the FLASH370i devices, ISR often allows users to change existing logic designs while simultaneously fixing pinout assignments.

The 64 macrocells in the CY7C372i are divided between four logic blocks. Each logic block includes 16 macrocells, a 72 x 86 product term array, and an intelligent product term allocator.

The logic blocks in the FLASH370i architecture are connected with an extremely fast and predictable routing resource—the Programmable Interconnect Matrix (PIM). The PIM brings flexibility, routability, speed, and a uniform delay to the interconnect.

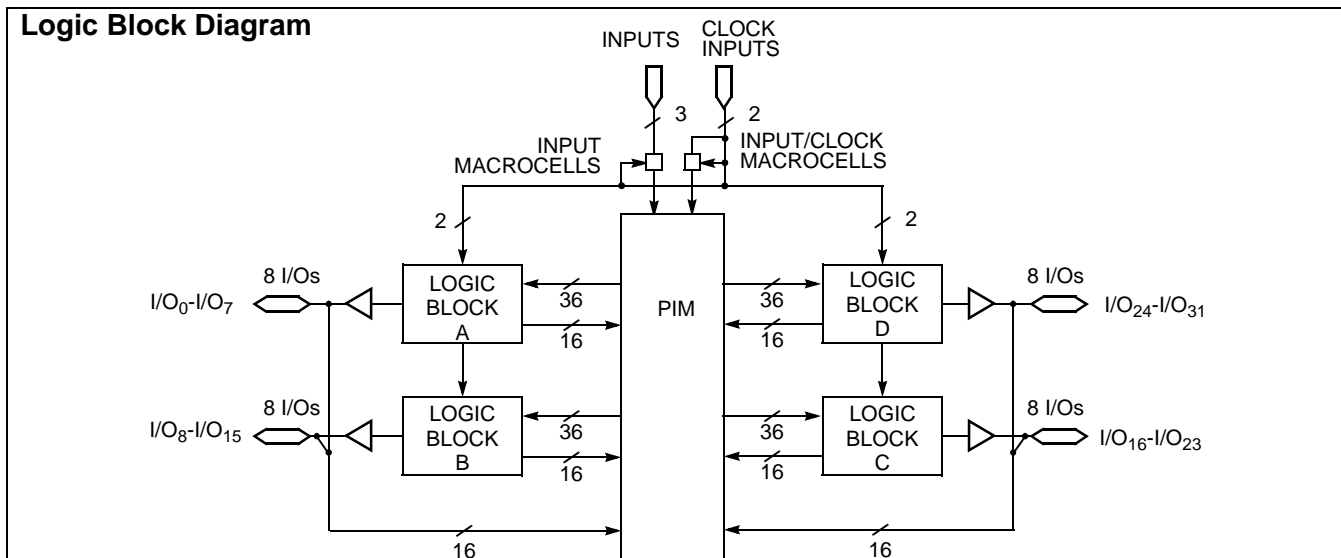

Selection Guide

	7C372i-125	7C372i-100	7C372i-83	7C372iL-83	7C372i-66	7C372iL-66
Maximum Propagation Delay ^[1] , t _{PD} (ns)	10	12	15	15	20	20
Minimum Set-up, t _S (ns)	5.5	6.0	8	8	10	10
Maximum Clock to Output ^[1] , t _{CO} (ns)	6.5	6.5	8	8	10	10
Typical Supply Current, I _{CC} (mA)	75	75	75	45	75	45

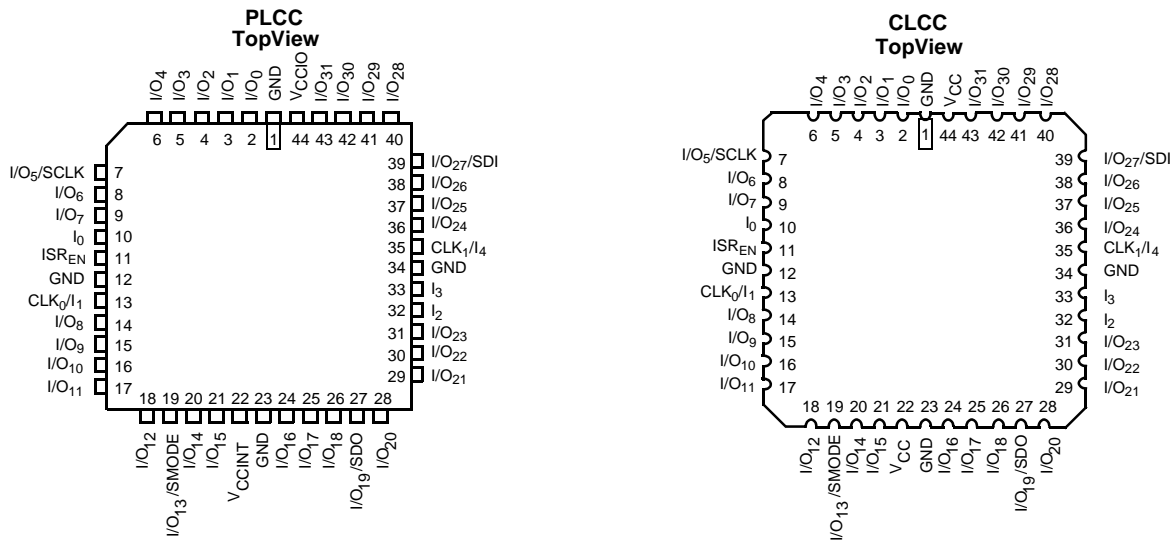
Pin Configurations

Note:

1. The 3.3V I/O mode timing adder, t_{3,3IO}, must be added to this specification when V_{CCIO} = 3.3V.

Functional Description

Like all members of the FLASH370i family, the CY7C372i is rich in I/O resources. Every two macrocells in the device feature an associated I/O pin, resulting in 32 I/O pins on the CY7C372i. In addition, there are three dedicated inputs and two input/clock pins.

Finally, the CY7C372i features a very simple timing model. Unlike other high-density CPLD architectures, there are no hidden speed delays such as fanout effects, interconnect delays, or expander delays. Regardless of the number of resources used, or the type of application, the timing parameters on the CY7C372i remain the same.

Logic Block

The number of logic blocks distinguishes the members of the FLASH370i family. The CY7C372i includes four logic blocks. Each logic block is constructed of a product term array, a product term allocator, and 16 macrocells.

Product Term Array

The product term array in the FLASH370i logic block includes 36 inputs from the PIM and outputs 86 product terms to the product term allocator. The 36 inputs from the PIM are available in both positive and negative polarity, making the overall array size 72 x 86. This large array in each logic block allows for very complex functions to be implemented in a single pass through the device.

Product Term Allocator

The product term allocator is a dynamic, configurable resource that shifts product terms to macrocells that require them. Any number of product terms between 0 and 16 inclusive can be assigned to any of the logic block macrocells (this is called product term steering). Furthermore, product terms can be shared among multiple macrocells. This means that product terms that are common to more than one output can be implemented in a single product term. Product term steering and product term sharing help to increase the effective density of the FLASH370 PLDs. Note that product term allocation is handled by software and is invisible to the user.

I/O Macrocell

Half of the macrocells on the CY7C372i have separate I/O pins associated with them. In other words, each I/O pin is shared by two macrocells. The input to the macrocell is the sum of between 0 and 16 product terms from the product term allocator. The macrocell includes a register that can be optionally bypassed. It also has polarity control, and two global clocks to trigger the register. The I/O macrocell also features a separate feedback path to the PIM so that the register can be buried if the I/O pin is used as an input.

Buried Macrocell

The buried macrocell is very similar to the I/O macrocell. Again, it includes a register that can be configured as combinatorial, as a D flip-flop, a T flip-flop, or a latch. The clock for this register has the same options as described for the I/O macrocell. One difference on the buried macrocell is the addition of input register capability. The user can program the buried macrocell to act as an input register (D-type or latch) whose input comes from the I/O pin associated with the neigh-

boring macrocell. The output of all buried macrocells is sent directly to the PIM regardless of its configuration.

Programmable Interconnect Matrix

The Programmable Interconnect Matrix (PIM) connects the four logic blocks on the CY7C372i to the inputs and to each other. All inputs (including feedbacks) travel through the PIM. There is no speed penalty incurred by signals traversing the PIM.

Programming

For an overview of ISR programming, refer to the FLASH370i Family data sheet and for ISR cable and software specifications, refer to ISR data sheets. For a detailed description of ISR capabilities, refer to the Cypress application note, "An Introduction to In System Reprogramming with FLASH370i."

PCI Compliance

The FLASH370i family of CMOS CPLDs are fully compliant with the PCI Local Bus Specification published by the PCI Special Interest Group. The simple and predictable timing model of FLASH370i ensures compliance with the PCI AC specifications independent of the design. On the other hand, in CPLD and FPGA architectures without simple and predictable timing, PCI compliance is dependent upon routing and product term distribution.

3.3V or 5.0V I/O operation

The FLASH370i family can be configured to operate in both 3.3V and 5.0V systems. All devices have two sets of V_{CC} pins: one set, V_{CCINT} , for internal operation and input buffers, and another set, V_{CCIO} , for I/O output drivers. V_{CCINT} pins must always be connected to a 5.0V power supply. However, the V_{CCIO} pins may be connected to either a 3.3V or 5.0V power supply, depending on the output requirements. When V_{CCIO} pins are connected to a 5.0V source, the I/O voltage levels are compatible with 5.0V systems. When V_{CCIO} pins are connected to a 3.3V source, the input voltage levels are compatible with both 5.0V and 3.3V systems, while the output voltage levels are compatible with 3.3V systems. There will be an additional timing delay on all output buffers when operating in 3.3V I/O mode. The added flexibility of 3.3V I/O capability is available in commercial and industrial temperature ranges.

Bus Hold Capabilities on all I/Os and Dedicated Inputs

In addition to ISR capability, a new feature called bus-hold has been added to all FLASH370i I/Os and dedicated input pins. Bus-hold, which is an improved version of the popular internal pull-up resistor, is a weak latch connected to the pin that does not degrade the device's performance. As a latch, bus-hold recalls the last state of a pin when it is three-stated, thus reducing system noise in bus-interface applications. Bus-hold additionally allows unused device pins to remain unconnected on the board, which is particularly useful during prototyping as designers can route new signals to the device without cutting trace connections to V_{CC} or GND.

Design Tools

Development software for the CY7C372i is available from Cypress's *Warp*™, *Warp Professional*™, and *Warp Enterprise*™ software packages. Please refer to the data sheets on these products for more details. Cypress also actively supports almost all third-party design tools. Please refer to third-party tool support for further information.



Maximum Ratings

(Above which the useful life may be impaired. For user guidelines, not tested.)

- Storage Temperature -65°C to +150°C
- Ambient Temperature with Power Applied..... -55°C to +125°C
- Supply Voltage to Ground Potential -0.5V to +7.0V
- DC Voltage Applied to Outputs in High-Z State -0.5V to +7.0V
- DC Input Voltage..... -0.5V to +7.0V
- DC Program Voltage 12.5V

- Output Current into Outputs 16 mA
- Static Discharge Voltage..... > 2001V (per MIL-STD-883, Method 3015)
- Latch-up Current..... > 200 mA

Operating Range

Range	Ambient Temperature	V _{CC} V _{CCINT}	V _{CCIO}
Commercial	0°C to +70°C	5V ± 0.25V	5V ± 0.25V or 3.3V ± 0.3V
Industrial	-40°C to +85°C	5V ± 0.5V	5V ± 0.5V 3.3V ± 0.3V
Military ^[2]	-55°C to + 125°C	5V ± 0.5V	

Electrical Characteristics Over the Operating Range^[3, 4]

Parameter	Description	Test Conditions	Min.	Typ.	Max.	Unit
V _{OH}	Output HIGH Voltage	V _{CC} = Min. I _{OH} = -3.2 mA (Com'l/Ind) ^[5] I _{OH} = -2.0 mA (Mil)	2.4			V
			2.4			V
V _{OHZ}	Output HIGH Voltage with Output Disabled ^[8]	V _{CC} = Max. I _{OH} = 0 μA (Com'l/Ind) ^[5, 6] I _{OH} = -50 μA (Com'l/Ind) ^[5, 6]			4.0	V
					3.6	V
V _{OL}	Output LOW Voltage	V _{CC} = Min. I _{OL} = 16 mA (Com'l/Ind) ^[5] I _{OL} = 12 mA (Mil)			0.5	V
					0.5	V
V _{IH}	Input HIGH Voltage	Guaranteed Input Logical HIGH Voltage for all Inputs ^[7]	2.0		7.0	V
V _{IL}	Input LOW Voltage	Guaranteed Input Logical LOW Voltage for all Inputs ^[7]	-0.5		0.8	V
I _{IX}	Input Load Current	V _I = Internal GND, V _I = V _{CC}	-10		+10	μA
I _{OZ}	Output Leakage Current	V _{CC} = Max., V _O = GND or V _O = V _{CC} , Output Disabled V _{CC} = Max., V _O = 3.3V, Output Disabled ^[6]	-50		+50	μA
			0	-70	-125	μA
I _{OS}	Output Short Circuit Current ^[8, 9]	V _{CC} = Max., V _{OUT} = 0.5V	-30		-160	mA
I _{CC}	Power Supply Current ^[10]	V _{CC} = Max., I _{OUT} = 0 mA, f = 1 MHz, V _{IN} = GND, V _{CC}	Com'l/Ind.	75	125	mA
			Com'l "L" -66	45	75	mA
			Military	75	200	mA
I _{BHL}	Input Bus Hold LOW Sustaining Current	V _{CC} = Min., V _{IL} = 0.8V	+75			μA
I _{BHH}	Input Bus Hold HIGH Sustaining Current	V _{CC} = Min., V _{IH} = 2.0V	-75			μA
I _{BHLO}	Input Bus Hold LOW Overdrive Current	V _{CC} = Max.			+500	μA
I _{BHHO}	Input Bus Hold HIGH Overdrive Current	V _{CC} = Max.			-500	μA

Notes:

2. T_A is the "instant on" case temperature.
3. See the last page of this specification for Group A subgroup testing information.
4. If V_{CCIO} is not specified, the device can be operating in either 3.3V or 5V I/O mode; V_{CC} = V_{CCINT}.
5. For SDO: I_{OH} = -2 mA, I_{OL} = 2 mA.
6. When the I/O is three-stated, the bus-hold circuit can weakly pull the I/O to a maximum of 4.0V if no leakage current is allowed. This voltage is lowered significantly by a small leakage current. Note that all I/Os are three-stated during ISR programming. Refer to the application note "Understanding Bus Hold" for additional information.
7. These are absolute values with respect to device ground. All overshoots due to system or tester noise are included.
8. Not more than one output should be tested at a time. Duration of the short circuit should not exceed 1 second. V_{OUT} = 0.5V has been chosen to avoid test problems caused by tester ground degradation.
9. Tested initially and after any design or process changes that may affect these parameters.
10. Measured with 16-bit counter programmed into each logic block.

Capacitance^[9]

Parameter	Description	Test Conditions	Min.	Max.	Unit
$C_{I/O}$ ^[11, 12]	Input Capacitance	$V_{IN} = 5.0V$ at $f = 1$ MHz		8	pF
C_{CLK}	Clock Signal Capacitance	$V_{IN} = 5.0V$ at $f = 1$ MHz	5	12	pF

Inductance^[9]

Parameter	Description	Test Conditions	44-Lead CLCC	44-Lead PLCC	Unit
L	Maximum Pin Inductance	$V_{IN} = 5.0V$ at $f = 1$ MHz	2	5	nH

Endurance Characteristics^[9]

Parameter	Description	Test Conditions	Max.	Unit
N	Maximum Reprogramming Cycles	Normal Programming Conditions	100	Cycles

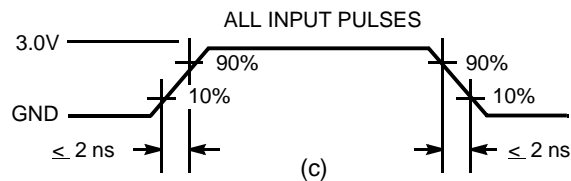
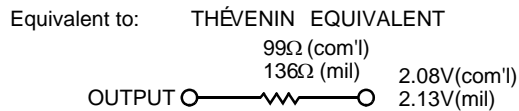
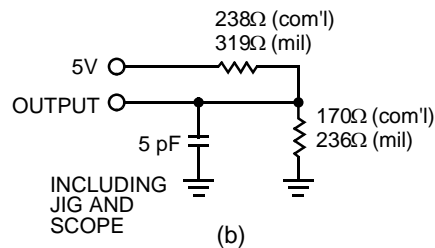
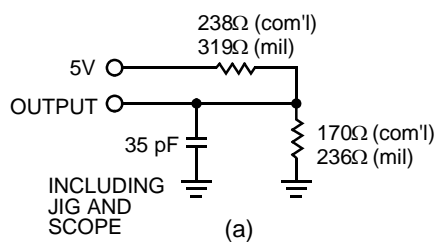
AC Test Loads and Waveforms

Parameter ^[13]	V_x	Output Waveform Measurement Level
$t_{ER(-)}$	1.5V	
$t_{ER(+)}$	2.6V	
$t_{EA(+)}$	1.5V	
$t_{EA(-)}$	V_{the}	

(d) Test Waveforms
Note:

11. $C_{I/O}$ for dedicated Inputs, and for I/O pins with JTAG functionality is 12 pF Max., and for ISR_{EN} is 15 pF Max.
12. $C_{I/O}$ for CLCC package is 15 pF Max.
13. t_{ER} measured with 5-pF AC Test Load and t_{EA} measured with 35-pF AC Test Load.

Switching Characteristics Over the Operating Range ^[14]

Parameter	Description	7C372i-125		7C372i-100		7C372i-83 7C372iL-83		7C372i-66 7C372iL-66		Unit
		Min.	Max.	Min.	Max.	Min.	Max.	Min.	Max.	
Combinatorial Mode Parameters										
t _{PD}	Input to Combinatorial Output ^[1]		10		12		15		20	ns
t _{PDL}	Input to Output Through Transparent Input or Output Latch ^[1]		13		15		18		22	ns
t _{PDLL}	Input to Output Through Transparent Input and Output Latches ^[1]		15		16		19		24	ns
t _{EA}	Input to Output Enable ^[1]		14		16		19		24	ns
t _{ER}	Input to Output Disable		14		16		19		24	ns
Input Registered/Latched Mode Parameters										
t _{WL}	Clock or Latch Enable Input LOW Time ^[9]	3		3		4		5		ns
t _{WH}	Clock or Latch Enable Input HIGH Time ^[9]	3		3		4		5		ns
t _{IS}	Input Register or Latch Set-Up Time	2		2		3		4		ns
t _{IH}	Input Register or Latch Hold Time	2		2		3		4		ns
t _{ICO}	Input Register Clock or Latch Enable to Combinatorial Output ^[1]		14		16		19		24	ns
t _{ICOL}	Input Register Clock or Latch Enable to Output Through Transparent Output Latch ^[1]		16		18		21		26	ns
Output Registered/Latched Mode Parameters										
t _{CO}	Clock or Latch Enable to Output ^[1]		6.5		6.5		8		10	ns
t _S	Set-Up Time from Input to Clock or Latch Enable	5.5		6		8		10		ns
t _H	Register or Latch Data Hold Time	0		0		0		0		ns
t _{CO2}	Output Clock or Latch Enable to Output Delay (Through Memory Array) ^[1]		14		16		19		24	ns
t _{SCS}	Output Clock or Latch Enable to Output Clock or Latch Enable (Through Memory Array)	8		10		12		15		ns
t _{SL}	Set-Up Time from Input Through Transparent Latch to Output Register Clock or Latch Enable	10		12		15		20		ns
t _{HL}	Hold Time for Input Through Transparent Latch from Output Register Clock or Latch Enable	0		0		0		0		ns
f _{MAX1}	Maximum Frequency with Internal Feedback in Output Registered Mode (Least of 1/t _{SCS} , 1/(t _S + t _H), or 1/t _{CO}) ^[9]	125		100		83		66		MHz
f _{MAX2}	Maximum Frequency Data Path in Output Registered/Latched Mode (Lesser of 1/(t _{WL} + t _{WH}), 1/(t _S + t _H), or 1/t _{CO}) ^[9]	153.8		153.8		125		100		MHz
f _{MAX3}	Maximum Frequency with External Feedback (Lesser of 1/(t _{CO} + t _S) and 1/(t _{WL} + t _{WH})) ^[9]	83.3		80		62.5		50		MHz
t _{OH} -t _{IH} 37x	Output Data Stable from Output clock Minus Input Register Hold Time for 7C37x ^[9, 15]	0		0		0		0		ns
Pipelined Mode Parameters										
t _{ICS}	Input Register Clock to Output Register Clock	8		10		12		15		ns
f _{MAX4}	Maximum Frequency in Pipelined Mode (Least of 1/(t _{CO} + t _S), 1/t _{ICS} , 1/(t _{WL} + t _{WH}), 1/(t _S + t _H), or 1/t _{SCS}) ^[9]	125		100		83.3		66.6		MHz

Notes:

14. All AC parameters are measured with 16 outputs switching and 35-pF AC Test Load.

15. This specification is intended to guarantee interface compatibility of the other members of the CY7C370i family with the CY7C372i. This specification is met for the devices operating at the same ambient temperature and at the same power supply voltage.

Switching Characteristics Over the Operating Range (continued)^[14]

Parameter	Description	7C372i-125		7C372i-100		7C372i-83 7C372iL-83		7C372i-66 7C372iL-66		Unit
		Min.	Max.	Min.	Max.	Min.	Max.	Min.	Max.	
Reset/Preset Parameters										
t _{RW}	Asynchronous Reset Width ^[9]	10		12		15		20		ns
t _{RR}	Asynchronous Reset Recovery Time ^[9]	12		14		17		22		ns
t _{RO}	Asynchronous Reset to Output ^[1]		16		18		21		26	ns
t _{PW}	Asynchronous Preset Width ^[9]	10		12		15		20		ns
t _{PR}	Asynchronous Preset Recovery Time ^[9]	12		14		17		22		ns
t _{PO}	Asynchronous Preset to Output ^[1]		16		18		21		26	ns
Tap Controller Parameter										
f _{TAP}	Tap Controller Frequency	500		500		500		500		kHz
3.3V I/O Mode Parameters										
t _{3.3IO}	3.3V I/O Mode Timing Adder		1		1		1		1	ns

Switching Waveforms

Combinatorial Output

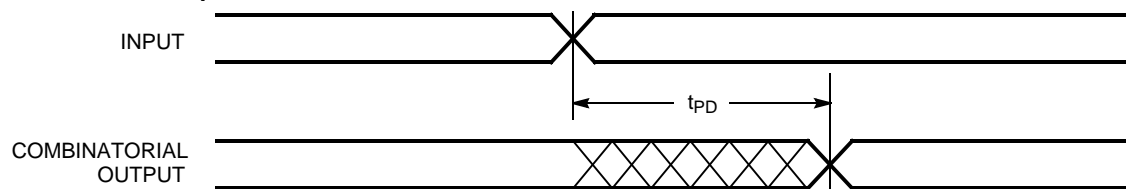

Registered Output

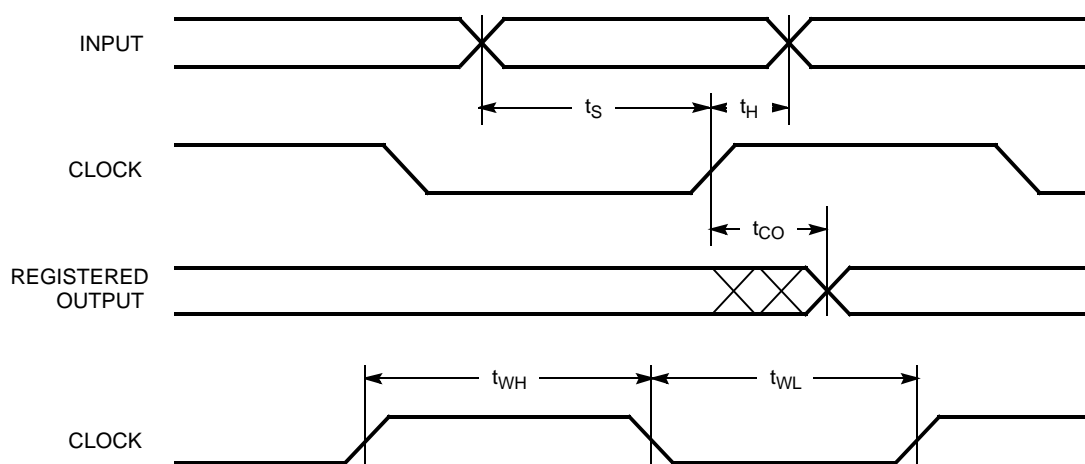

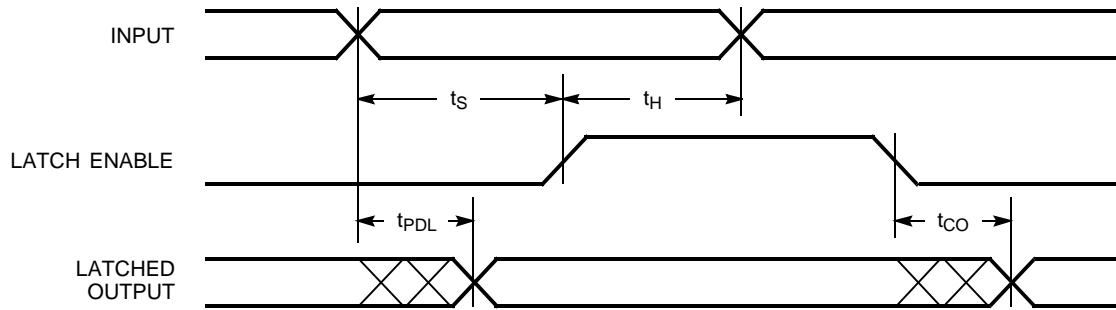
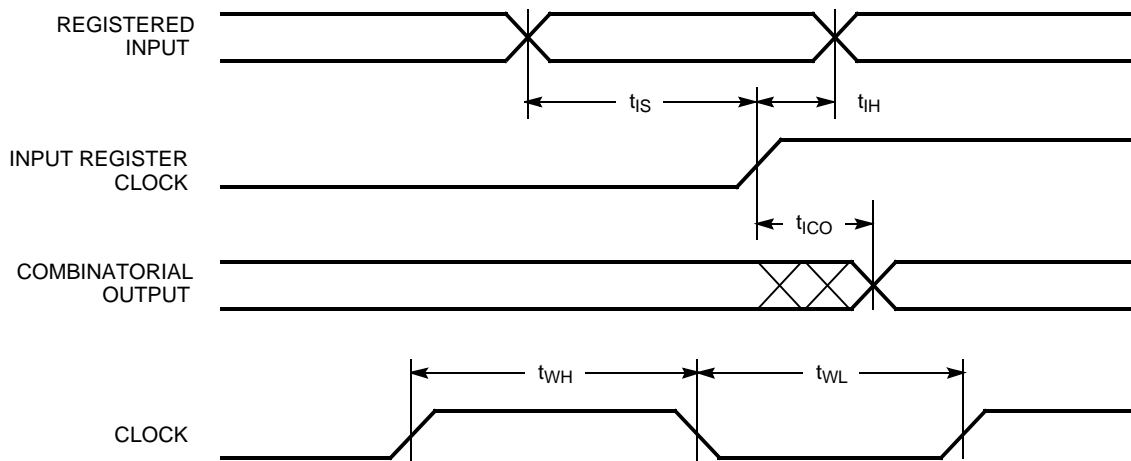
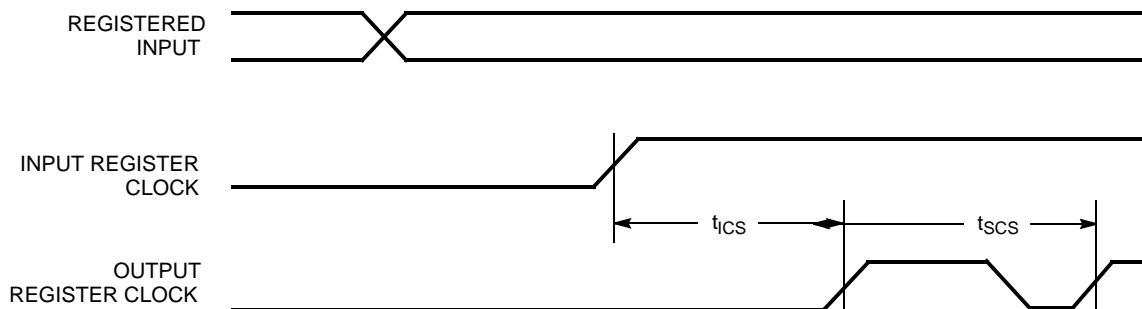
Switching Waveforms (continued)
Latched Output

Registered Input

Clock to Clock

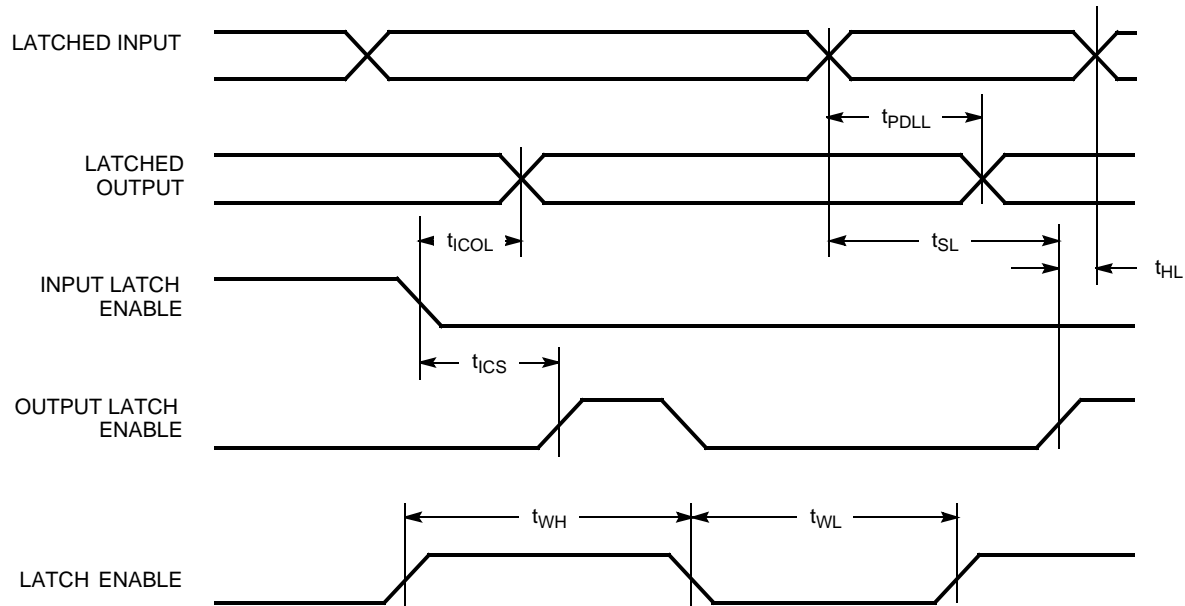
Switching Waveforms (continued)

Latched Input and Output

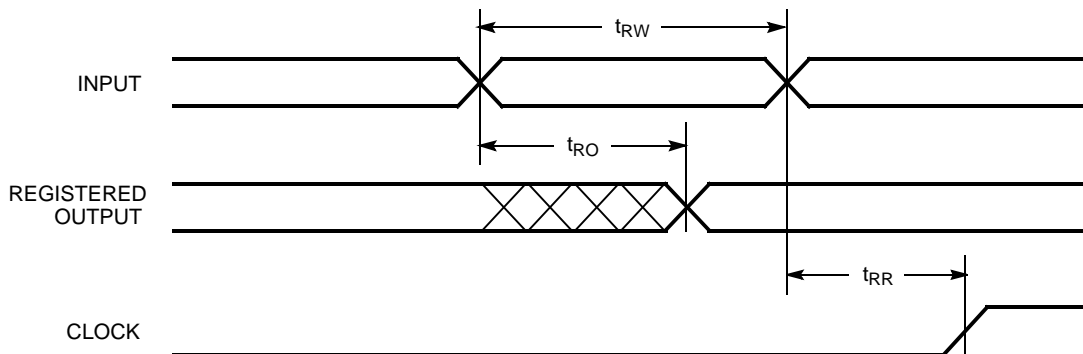

Asynchronous Reset



Asynchronous Preset

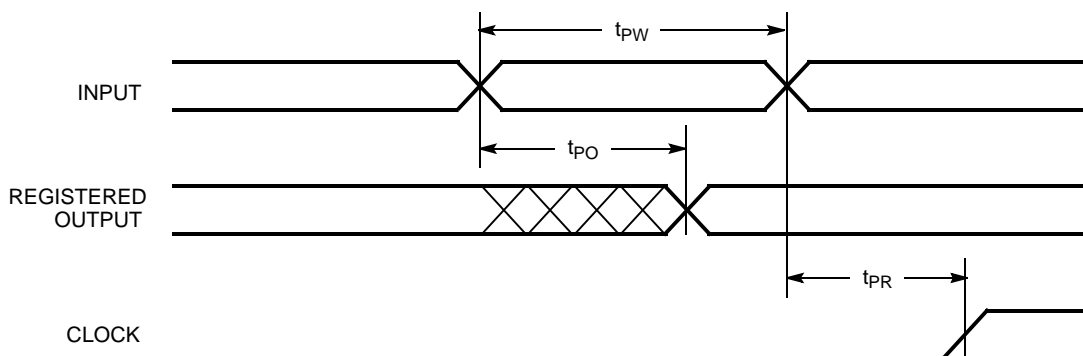

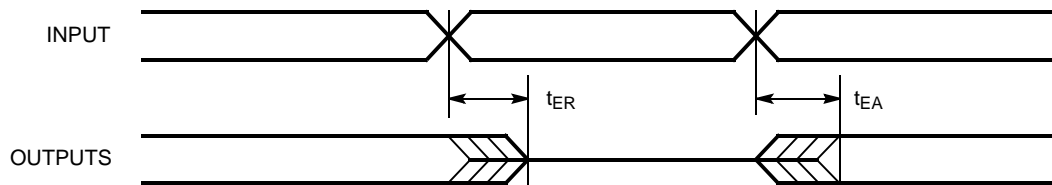
Switching Waveforms (continued)
Output Enable/Disable

Ordering Information

Speed (MHz)	Ordering Code	Package Name	Package Type	Operating Range
125	CY7C372i-125JC	J67	44-Lead Plastic Leaded Chip Carrier	Commercial
100	CY7C372i-100JC	J67	44-Lead Plastic Leaded Chip Carrier	Commercial
	CY7C372i-100JI	J67	44-Lead Plastic Leaded Chip Carrier	Industrial
83	CY7C372i-83JC	J67	44-Lead Plastic Leaded Chip Carrier	Commercial
	CY7C372i-83JI	J67	44-Lead Plastic Leaded Chip Carrier	Industrial
	CY7C372i-83YMB	Y67	44-Lead Ceramic Leaded Chip Carrier	Military
83	CY7C372iL-83JC	J67	44-Lead Plastic Leaded Chip Carrier	Commercial
66	CY7C372i-66JC	J67	44-Lead Plastic Leaded Chip Carrier	Commercial
	CY7C372i-66JI	J67	44-Lead Plastic Leaded Chip Carrier	Industrial
	CY7C372i-66YMB	Y67	44-Lead Ceramic Leaded Chip Carrier	Military
66	CY7C372iL-66JC	J67	44-Lead Plastic Leaded Chip Carrier	Commercial

**MILITARY SPECIFICATIONS
Group A Subgroup Testing****DC Characteristics**

Parameter	Subgroups
V _{OH}	1, 2, 3
V _{OL}	1, 2, 3
V _{IH}	1, 2, 3
V _{IL}	1, 2, 3
I _{Ix}	1, 2, 3
I _{OZ}	1, 2, 3
I _{CC}	1, 2, 3

Switching Characteristics

Parameter	Subgroups
t _{PD}	9, 10, 11
t _{CO}	9, 10, 11
t _{ICO}	9, 10, 11
t _S	9, 10, 11
t _H	9, 10, 11
t _{IS}	9, 10, 11
t _{IH}	9, 10, 11
t _{ICS}	9, 10, 11

Package Diagrams**44-Lead Plastic Leaded Chip Carrier J67**

51-85003-*A

Package Diagrams (continued)

44-Pin Ceramic Leaded Chip Carrier Y67

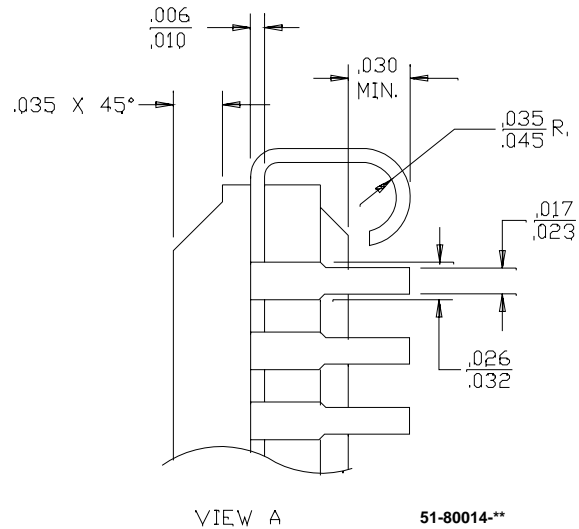
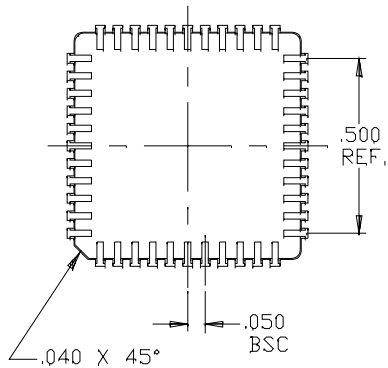
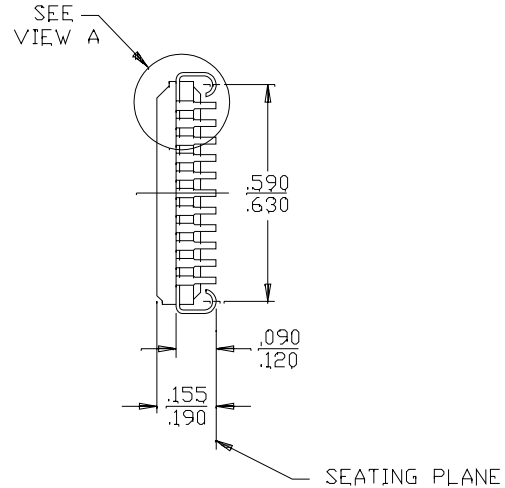
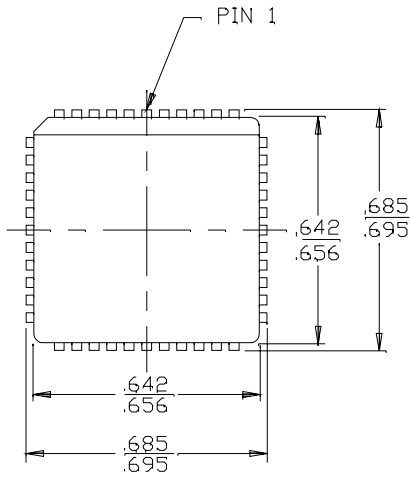

51-80014-**

ISR, UltraLogic, FLASH370, FLASH370i, Warp, Warp Professional, and Warp Enterprise, are trademarks of Cypress Semiconductor Corporation.



**USE ULTRA37000™
FOR ALL NEW DESIGNS**

CY7C372i

Document History Page

Document Title: CY7C372i UltraLogic™ 64-Macrocell Flash CPLD Document Number: 38-03033				
REV.	ECN NO.	Issue Date	Orig. of Change	Description of Change
**	106378	06/18/01	SZV	Change from Spec# 38-00498 to 38-03033
*A	213375	See ECN	FSG	Added note to title page: "Use Ultra37000 For All New Designs"