



FAST CMOS OCTAL LATCHED TRANSCEIVER

IDT54/74FCT543/A/C

FEATURES:

- IDT54FCT543 equivalent to FAST™ speed
- IDT54/74FCT543A up to 25% faster than FAST
- IDT74FCT543C up to 40% faster than FAST
- Equivalent to FAST output drive over full temperature and voltage supply extremes
- $I_{OL} = 64\text{mA}$ (commercial) and 48mA (military)
- Separate controls for data flow in each direction
- Back-to-back latches for storage
- CMOS power levels (1mW typ. static)
- Substantially lower input current levels than FAST ($5\mu\text{A}$ max.)
- TTL input and output level compatible
- CMOS output level compatible
- Military product compliant to MIL-STD-883, Class B
- Available in the following packages:
 - Commercial: SOIC
 - Military: CERDIP, LCC

DESCRIPTION:

The FCT543 is a non-inverting octal transceiver built using an advanced dual metal CMOS technology. These devices contain two sets of eight D-type latches with separate input and output controls for each set. For data flow from A to B, for example, the A-to-B Enable ($\overline{\text{CEAB}}$) input must be low in order to enter data from A0–A7 or to take data from B0–B7, as indicated in the Function Table. With $\overline{\text{CEAB}}$ low, a low signal on the A-to-B Latch Enable ($\overline{\text{LEAB}}$) input makes the A-to-B latches transparent; a subsequent low-to-high transition of the $\overline{\text{LEAB}}$ signal puts the A latches in the storage mode and their outputs no longer change with the A inputs. With $\overline{\text{CEAB}}$ and $\overline{\text{OEAB}}$ both low, the 3-state B output buffers are active and reflect the data present at the output of the A latches. Control of data from B to A is similar, but uses the $\overline{\text{CEBA}}$, $\overline{\text{LEBA}}$ and $\overline{\text{OEBA}}$ inputs.

FUNCTIONAL BLOCK DIAGRAM

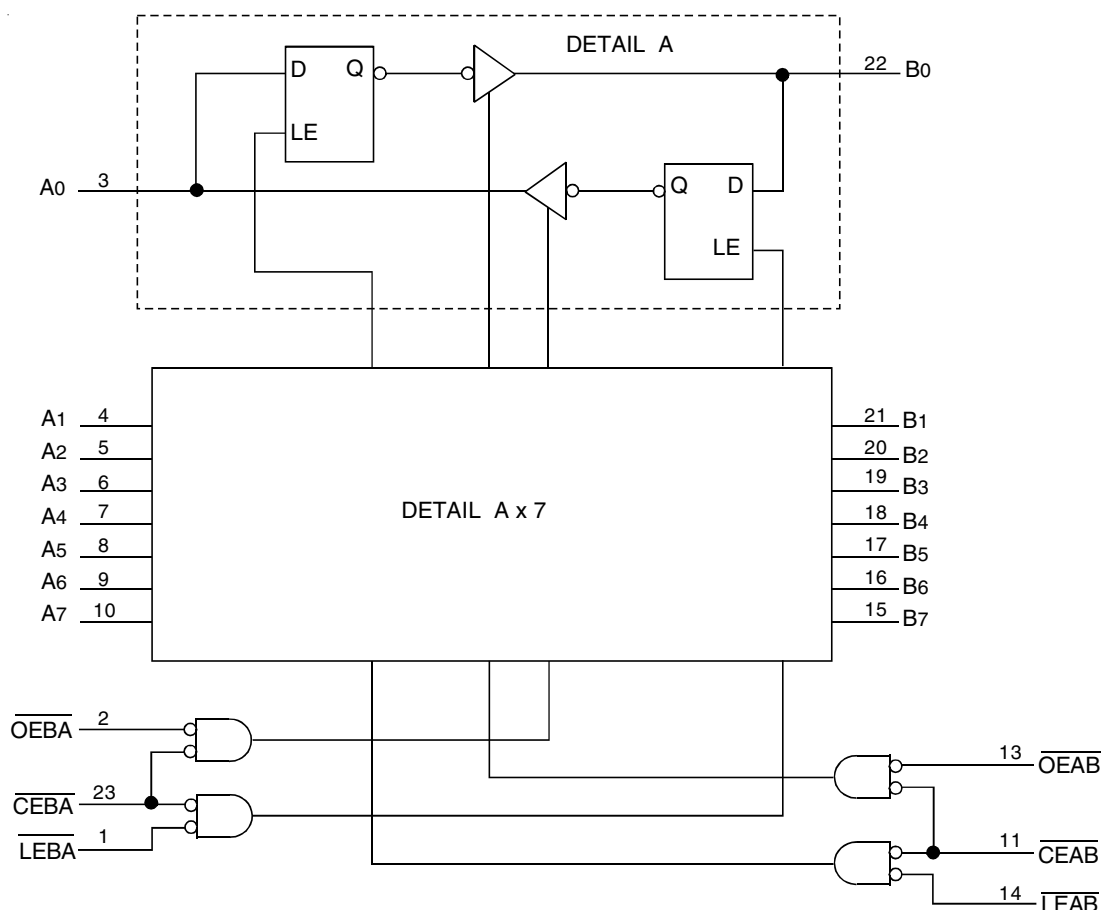

The IDT logo is a registered trademark of Integrated Device Technology, Inc.

MILITARY AND COMMERCIAL TEMPERATURE RANGES

JUNE 2002

PIN CONFIGURATION

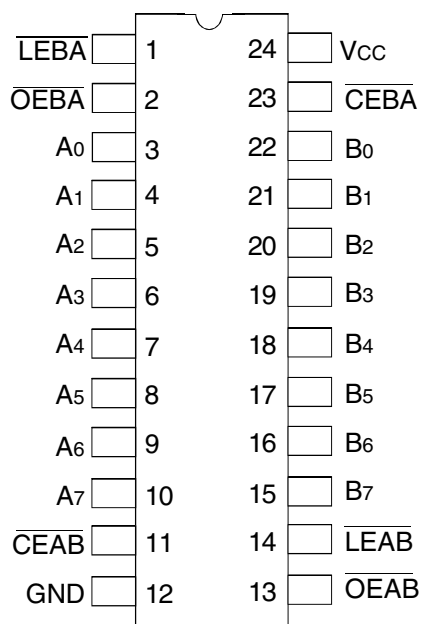

CERDIP/ SOIC
TOP VIEW

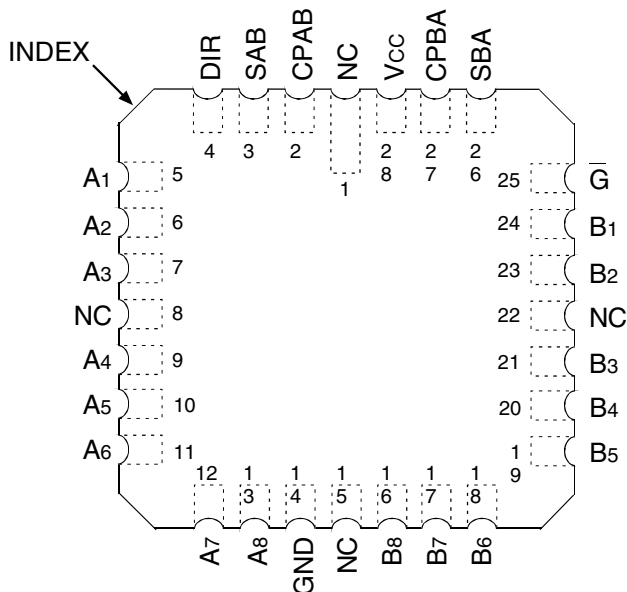

LCC
TOP VIEW

ABSOLUTE MAXIMUM RATINGS⁽¹⁾

Symbol	Rating	Commercial	Military	Unit
V _{TERM} ⁽²⁾	Terminal Voltage with Respect to GND	-0.5 to +7	-0.5 to +7	V
V _{TERM} ⁽³⁾	Terminal Voltage with Respect to GND	-0.5 to V _{CC}	-0.5 to V _{CC}	V
T _A	Operating Temperature	0 to +70	-55 to +125	°C
T _{BIAS}	Temperature under BIAS	-55 to +125	-65 to +135	°C
T _{STG}	Storage Temperature	-55 to +125	-65 to +150	°C
P _T	Power Dissipation	0.5	0.5	W
I _{OUT}	DC Output Current	120	120	mA

NOTES:

- Stresses greater than those listed under ABSOLUTE MAXIMUM RATINGS may cause permanent damage to the device. This is a stress rating only and functional operation of the device at these or any other conditions above those indicated in the operational sections of this specification is not implied. Exposure to absolute maximum rating conditions for extended periods may affect reliability. No terminal voltage may exceed V_{CC} by +0.5V unless otherwise noted.
- Input and V_{CC} terminals only.
- Output and I/O terminals only.

CAPACITANCE (T_A = +25°C, F = 1.0MHz)

Symbol	Parameter ⁽¹⁾	Conditions	Typ.	Max.	Unit
C _{IN}	Input Capacitance	V _{IN} = 0V	6	10	pF
C _{OUT}	Output Capacitance	V _{OUT} = 0V	8	12	pF

NOTE:

- This parameter is measured at characterization but not tested.

LOGIC SYMBOL

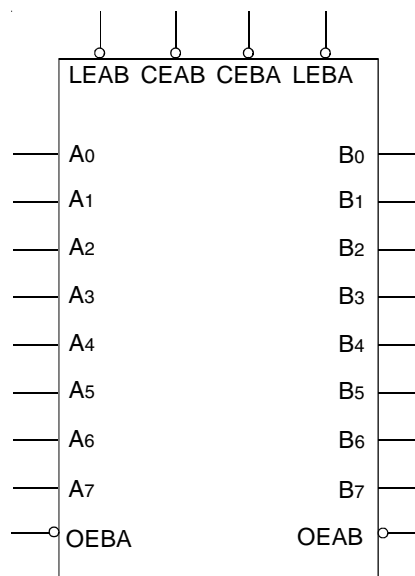

PIN DESCRIPTION

Pin Names	Description
\overline{OEAB}	A-to-B Output Enable Input (Active LOW)
\overline{OEBA}	B-to-A Output Enable Input (Active LOW)
\overline{CEAB}	A-to-B Enable Input (Active LOW)
\overline{CEBA}	B-to-A Enable Input (Active LOW)
\overline{LEAB}	A-to-B Latch Enable Input (Active LOW)
\overline{LEBA}	B-to-A Latch Enable Input (Active LOW)
A ₀ -A ₇	A-to-B Data Inputs or B-to-A 3-State Outputs
B ₀ -B ₇	B-to-A Data Inputs or A-to-B 3-State Outputs

FUNCTION TABLE^(1, 2)

For A-to-B (Symmetric with B-to-A)

Inputs			Latch Status	Output Buffers
\overline{CEAB}	\overline{LEAB}	\overline{OEAB}	A-to-B	B ₀ -B ₇
H	X	X	Storing	High Z
X	H	X	Storing	X
X	X	H	X	High Z
L	L	L	Transparent	Current A Inputs
L	H	L	Storing	Previous* A Inputs

NOTES:

- * Before \overline{LEAB} LOW-to-HIGH Transition
H = HIGH Voltage Level
L = LOW Voltage Level
X = Don't Care
- A-to-B data flow shown; B-to-A flow control is the same, except using \overline{CEBA} , \overline{LEBA} and \overline{OEBA} .

DC ELECTRICAL CHARACTERISTICS OVER OPERATING RANGE

Following Conditions Apply Unless Otherwise Specified: $V_{LC} = 0.2V$; $V_{HC} = V_{CC} - 0.2V$

Commercial: $T_A = 0^\circ C$ to $+70^\circ C$, $V_{CC} = 5.0V \pm 5\%$, Military: $T_A = -55^\circ C$ to $+125^\circ C$, $V_{CC} = 5.0V \pm 10\%$

Symbol	Parameter	Test Conditions ⁽¹⁾	Min.	Typ. ⁽²⁾	Max.	Unit	
V_{IH}	Input HIGH Level	Guaranteed Logic HIGH Level	2	—	—	V	
V_{IL}	Input LOW Level	Guaranteed Logic LOW Level	—	—	0.8	V	
I_{IH}	Input HIGH Current	$V_{CC} = \text{Max.}$	$V_i = V_{CC}$	—	—	5	μA
I_{IL}	Input LOW Current		$V_i = 2.7V$	—	—	5 ⁽⁴⁾	
			$V_i = 0.5V$	—	—	-5 ⁽⁴⁾	
			$V_i = GND$	—	—	-5	
I_{OZH}	Off State (High Impedance) Output Current	$V_{CC} = \text{Max.}$	$V_o = V_{CC}$	—	—	10	μA
I_{OZL}			$V_o = 2.7V$	—	—	10 ⁽⁴⁾	
			$V_o = 0.5V$	—	—	-10 ⁽⁴⁾	
			$V_o = GND$	—	—	-10	
V_{IK}	Clamp Diode Voltage	$V_{CC} = \text{Min.}, I_{IN} = -18mA$	—	-0.7	-1.2	V	
I_{OS}	Short Circuit Current	$V_{CC} = \text{Max.}, V_o = GND^{(3)}$	-60	-120	—	mA	
V_{OH}	Output HIGH Voltage	$V_{CC} = 3V, V_{IN} = V_{LC}$ or $V_{HC}, I_{OH} = -32\mu A$		V_{HC}	V_{CC}	—	V
		$V_{CC} = \text{Min}$ $V_{IN} = V_{IH}$ or V_{IL}	$I_{OH} = -300\mu A$	V_{HC}	V_{CC}	—	
			$I_{OH} = -12mA \text{ MIL}$	2.4	4.3	—	
			$I_{OH} = -15mA \text{ COM'L}$	2.4	4.3	—	
V_{OL}	Output LOW Voltage	$V_{CC} = 3V, V_{IN} = V_{LC}$ or $V_{HC}, I_{OL} = 300\mu A$		—	GND	V_{LC}	V
		$V_{CC} = \text{Min}$ $V_{IN} = V_{IH}$ or V_{IL}	$I_{OL} = 300\mu A$	—	GND	$V_{LC}^{(4)}$	
			$I_{OL} = 48mA \text{ MIL}$	—	0.3	0.55	
			$I_{OL} = 64mA \text{ COM'L}$	—	0.3	0.55	

NOTES:

- For conditions shown as Min. or Max., use appropriate value specified under Electrical Characteristics for the applicable device type.
- Typical values are at $V_{CC} = 5.0V$, $+25^\circ C$ ambient and maximum loading.
- Not more than one output should be tested at one time. Duration of the test should not exceed one second.
- This parameter is guaranteed but not tested.

POWER SUPPLY CHARACTERISTICS

$V_{LC} = 0.2V$; $V_{HC} = V_{CC} - 0.2V$

Symbol	Parameter	Test Conditions ⁽¹⁾		Min.	Typ. ⁽²⁾	Max.	Unit
I _{CC}	Quiescent Power Supply Current	V _{CC} = Max. V _{IN} ≥ V _{HC} ; V _{IN} ≤ V _{LC}		—	0.2	1.5	mA
ΔI _{CC}	Quiescent Power Supply Current TTL Inputs HIGH	V _{CC} = Max. V _{IN} = 3.4V ⁽³⁾		—	0.5	2	mA
I _{CCD}	Dynamic Power Supply Current ⁽⁴⁾	V _{CC} = Max. Outputs Open \overline{CEAB} and \overline{OEAB} = GND \overline{CEBA} = V _{CC} One Input Toggling 50% Duty Cycle	V _{IN} ≥ V _{HC} V _{IN} ≤ V _{LC}	—	0.15	0.25	mA/ MHz
I _C	Total Power Supply Current ⁽⁶⁾	V _{CC} = Max. Outputs Open f _{CP} = 10MHz (\overline{LEAB}) 50% Duty Cycle \overline{CEAB} and \overline{OEAB} = GND \overline{CEBA} = V _{CC} One Bit Toggling at f _i = 5MHz	V _{IN} ≥ V _{HC} V _{IN} ≤ V _{LC} (FCT)	—	1.7	4	mA
			V _{IN} = 3.4V V _{IN} = GND	—	2.2	6	
		V _{CC} = Max. Outputs Open f _{CP} = 10MHz (\overline{LEAB}) 50% Duty Cycle \overline{CEAB} and \overline{OEAB} = GND \overline{CEBA} = V _{CC} Eight Bits Toggling at f _i = 5MHz	V _{IN} ≥ V _{HC} V _{IN} ≤ V _{LC} (FCT)	—	7	12.8 ⁽⁵⁾	
			V _{IN} = 3.4V V _{IN} = GND	—	9.2	21.8 ⁽⁵⁾	

NOTES:

- For conditions shown as Min. or Max., use appropriate value specified under Electrical Characteristics for the applicable device type.
- Typical values are at V_{CC} = 5.0V, +25°C ambient.
- Per TTL driven input; (V_{IN} = 3.4V). All other inputs at V_{CC} or GND.
- This parameter is not directly testable, but is derived for use in Total Power Supply Calculations.
- Values for these conditions are examples of ΔI_{CC} formula. These limits are guaranteed but not tested.
- I_C = I_{QUIESCENT} + I_{INPUTS} + I_{DYNAMIC}
I_C = I_{CC} + ΔI_{CC} D_HN_T + I_{CCD} (f_{CP}/2 + f_iN_i)
I_{CC} = Quiescent Current
ΔI_{CC} = Power Supply Current for a TTL High Input (V_{IN} = 3.4V)
D_H = Duty Cycle for TTL Inputs High
N_T = Number of TTL Inputs at D_H
I_{CCD} = Dynamic Current caused by an Input Transition Pair (HLH or LHL)
f_{CP} = Clock Frequency for Register Devices (Zero for Non-Register Devices)
f_i = Output Frequency
N_i = Number of Outputs at f_i
All currents are in milliamps and all frequencies are in megahertz.

SWITCHING CHARACTERISTICS OVER OPERATING RANGE

Symbol	Parameter	Condition ⁽¹⁾	54FCT543		54/74FCT543A				74FCT543C		Unit
			Mil.		Com'l.		Mil.		Com'l.		
			Min. ⁽²⁾	Max.	Min. ⁽²⁾	Max.	Min. ⁽²⁾	Max.	Min. ⁽²⁾	Max.	
t _{PLH} t _{PHL}	Propagation Delay Transparent Mode Ax to Bx or Bx to Ax	C _L = 50pF R _L = 500Ω	2.5	10	2.5	6.5	2.5	7.5	2.5	5.3	ns
t _{PLH} t _{PHL}	Propagation Delay \overline{LEBA} to Ax, \overline{LEAB} to Bx		2.5	14	2.5	8	2.5	9	2.5	7	ns
t _{PZH} t _{PZL}	Output Enable Time \overline{OEBA} or \overline{OEAB} to Ax or Bx \overline{CEBA} or \overline{CEAB} to Ax or Bx		2	14	2	9	2	10	2	8	ns
t _{PHZ} t _{PLZ}	Output Disable Time \overline{OEBA} or \overline{OEAB} to Ax or Bx \overline{CEBA} or \overline{CEAB} to Ax or Bx		2	13	2	7.5	2	8.5	2	6.5	ns
t _{SU}	Set-up Time, HIGH or LOW Ax or Bx to \overline{LEBA} or \overline{LEAB}		3	—	2	—	2	—	2	—	ns
t _H	Hold Time, HIGH or LOW Ax or Bx to \overline{LEBA} or \overline{LEAB}		2	—	2	—	2	—	2	—	ns
t _w	\overline{LEBA} or \overline{LEAB} Pulse Width LOW		5	—	5	—	5	—	5	—	ns

NOTES:

1. See test circuit and waveforms.
2. Minimum limits are guaranteed but not tested on Propagation Delays.

TEST CIRCUITS AND WAVEFORMS

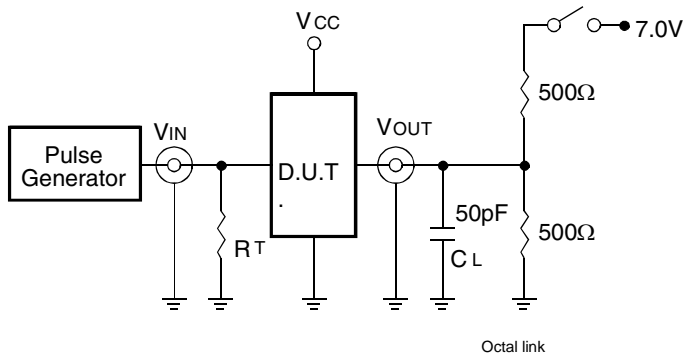

Test Circuits for All Outputs

SWITCH POSITION

Test	Switch
Open Drain Disable Low Enable Low	Closed
All Other Tests	Open

DEFINITIONS:

CL = Load capacitance: includes jig and probe capacitance.
RT = Termination resistance: should be equal to ZOUT of the Pulse Generator.

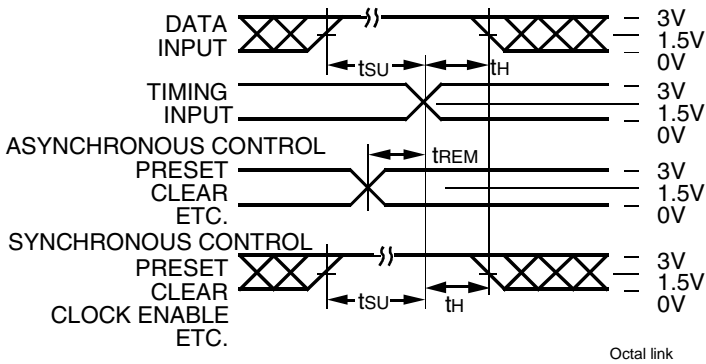

Set-Up, Hold, and Release Times

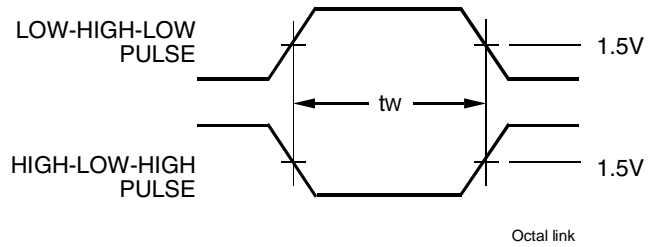

Pulse Width

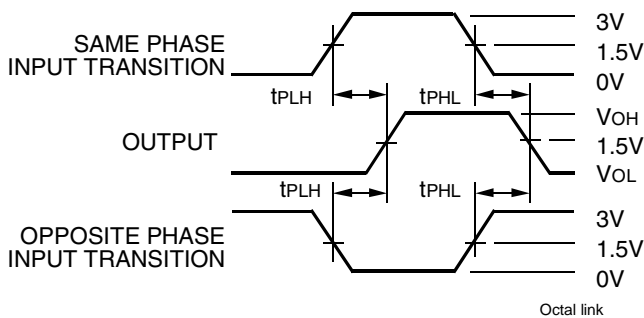

Propagation Delay

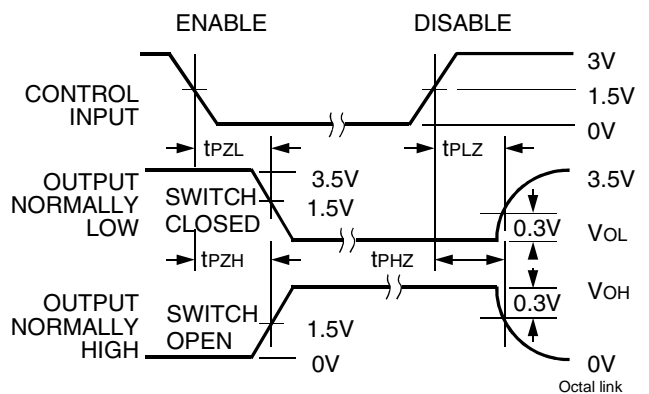

Enable and Disable Times

NOTES:

- Diagram shown for input Control Enable-LOW and input Control Disable-HIGH.
- Pulse Generator for All Pulses: Rate ≤ 1.0MHz; Zo ≤ 50Ω; tr ≤ 2.5ns; tr ≤ 2.5ns.

ORDERING INFORMATION

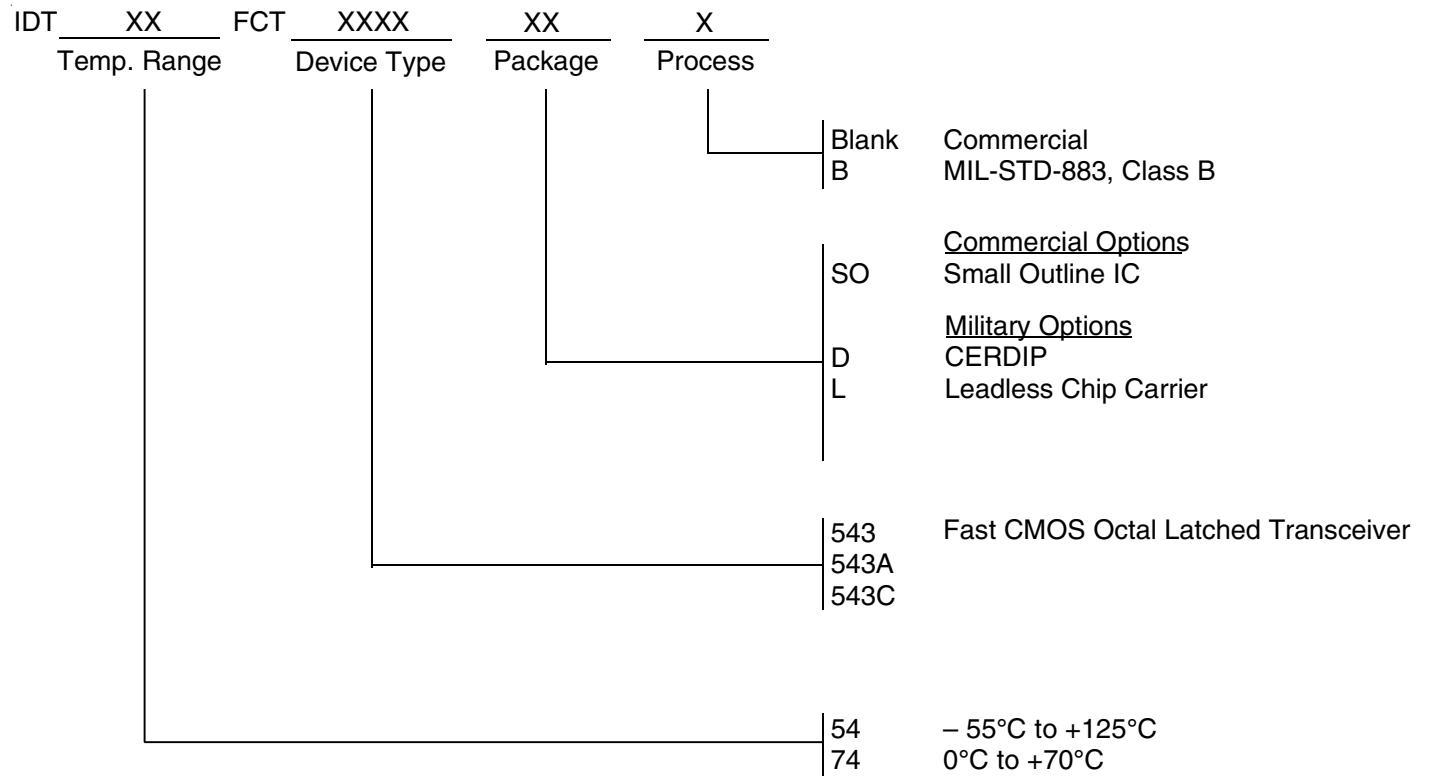

CORPORATE HEADQUARTERS
2975 Stender Way
Santa Clara, CA 95054

for SALES:
800-345-7015 or 408-727-6116
fax: 408-492-8674
www.idt.com

for Tech Support:
logichelp@idt.com
(408) 654-6459