



PRELIMINARY

CY2283

Pentium®/II, K6, 6x86 100-MHz Clock Synthesizer/Driver for Desktop PCs with ALI or VIA Chipsets, AGP and 3 DIMMs

Features

- Mixed 2.5V and 3.3V operation
- Complete clock solution for Pentium® /II, Cyrix 6x86, and AMD K6 processor-based motherboards
 - Four CPU clocks at 2.5V or 3.3V
 - Twelve 3.3V SDRAM clocks^[1]
 - Five synchronous PCI clocks, one free-running
 - One 3.3V 48 MHz USB clock
 - One 3.3V Ref. clock at 14.318 MHz
 - Two AGP clocks at 3.3V
- Support for ALI (-1 option) and VIA (-2 option)
- I²C™ Serial Configuration Interface
- Full EMI control with factory-EPROM programmable output drive and slew rate
- Factory-EPROM programmable CPU clock frequencies for custom configurations
- Power-down, CPU stop, and PCI stop pins
- Available in space-saving 48-pin SSOP package

Functional Description

The CY2283 is a clock Synthesizer/Driver for Pentium, Cyrix, or AMD processor-based PCs using the ALI Aladdin V (-1 option) or VIA MVP3 (-2 option) chipset.

The CY2283 outputs four CPU clocks at 2.5V or 3.3V. There are five PCI clocks, running at 30 or 33.3 MHz. One of the PCI clocks is free-running. Additionally, the part outputs twelve 3.3V SDRAM clocks^[1], one 3.3V USB clock at 48 MHz, and one 3.3V reference clock at 14.318 MHz. Finally, the part outputs two AGP clocks running at 66.66 MHz or 60 MHz.

The CY2283 has the flexibility to work as either a one-chip or as part of a two-chip clocking solution. In 100-MHz board designs based on the ALI Aladdin V chipset, it is recommended that the CY2283 be used with an external SDRAM buffer solution such as the CY2318NZ or CY2314NZ. In this configuration the SDRAM outputs on the CY2283 must be either turned off using I²C or left floating. The CY231xNZ family provides the

SDRAM outputs in place of the CY2283 and can be placed in close proximity to the SDRAM modules.

The CY2283 possesses power-down, CPU stop, and PCI stop pins for power management control. These inputs are multiplexed with SDRAM clock outputs, and are selected when the MODE pin is driven LOW. Additionally, the signals are synchronized on-chip, and ensure glitch-free transitions on the outputs. When the CPU_STOP input is asserted, the CPU clock outputs are driven LOW. When the PCI_STOP input is asserted, the PCI clock outputs (except the free-running PCI clock) are driven LOW. When the PWR_DWN pin is asserted, the reference oscillator and PLLs are shut down, and all outputs are driven LOW.

The CY2283 outputs are designed for low EMI emissions. Controlled rise and fall times, unique output driver circuits and factory-EPROM programmable output drive and slew-rate enable optimal configurations for EMI control.

CY2283 Selector Guide

Clock Outputs	-1 (ALI V)	-2 (VIA MVP3)
CPU (66.6, 75, 83.3, 100MHz)	4	4
SDRAM	12 ^[1]	12
PCI (30, 33.3 MHz)	5 ^[2]	5 ^[2]
USB (48MHz)	1	1
AGP (66.6, 60MHz)	2	2
Ref. (14.318 MHz)	1	1
CPU-PCI delay	2.5–5.5 ns	2.5–5.5 ns
AGP clock	In phase with PCI	In phase with CPU

Notes:

1. SDRAM clocks available up to 83.3MHz. In 100-MHz designs based on the ALI V chipset, an external CY231xNZ buffer should be used.
2. One free-running PCI clock

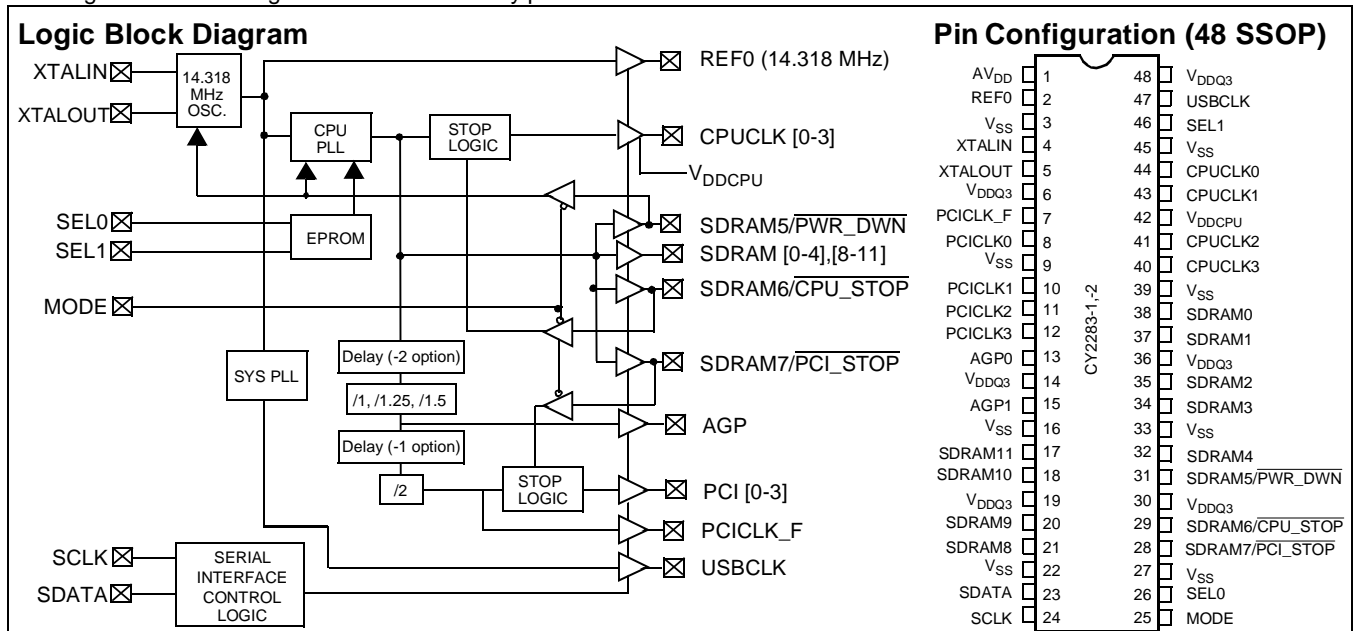

Pin Summary

Name	Pins	Description
V _{DDQ3}	6, 14, 19, 30, 36, 48	3.3V Digital voltage supply
V _{DDCPU}	42	CPU Digital voltage supply, 2.5V or 3.3V
AV _{DD}	1	Analog voltage supply, 3.3V
V _{SS}	3, 9, 16, 22, 27, 33, 39, 45	Ground
XTALIN ^[3]	4	Reference crystal input
XTALOUT ^[3]	5	Reference crystal feedback
SDRAM7/ $\overline{\text{PCI_STOP}}$	28	SDRAM clock output. Also, active LOW control input to stop PCI clocks, enabled when MODE is LOW.
SDRAM6/ $\overline{\text{CPU_STOP}}$	29	SDRAM clock output. Also, active LOW control input to stop CPU clocks, enabled when MODE is LOW.
SDRAM5/ $\overline{\text{PWR_DWN}}$	31	SDRAM clock output. Also, active LOW control input to power down device, enabled when MODE is LOW.
SDRAM[0:4],[8:11]	38, 37, 35, 34, 32, 21, 20, 18, 17	SDRAM clock outputs
SEL0	26	CPU frequency select input, bit 0 (see table below)
SEL1	46	CPU frequency select input, bit 0 (see table below)
CPUCLK[0:3]	44, 43, 41, 40	CPU clock outputs
PCICLK[0:3]	8, 10, 11, 12	PCI clock outputs, at one-half the CPU frequency.
PCICLK_F	7	Free-running PCI clock output
AGP[0:1]	13, 15	AGP clock outputs
REF0	2	3.3V Reference clock output
USBCLK	47	USB Clock output
SDATA	23	Serial data input for serial configuration port
SCLK	24	Serial clock input for serial configuration port
MODE	25	Mode Select pin for enabling power management features

Note:

3. For best accuracy, use a parallel-resonant crystal, C_{LOAD} = 18 pF.

Function Table

SEL1	SEL0	CPU/PCI Ratio	CPUCLK[0:3] SDRAM[0:11]	PCICLK[0:3] PCICLK_F	AGP[0:1]	REF0	USBCLK
0	0	2.5	83.33 MHz	33.33 MHz	66.66 MHz	14.318 MHz	48 MHz
0	1	2	66.67 MHz	33.33 MHz	66.66 MHz	14.318 MHz	48 MHz
1	0	3.0	100.0 MHz	33.33 MHz	66.66 MHz	14.318 MHz	48 MHz
1	1	2.5	75.0 MHz	30.0 MHz	60.0 MHz	14.318 MHz	48 MHz

Actual Clock Frequency Values

Clock Output	Target Frequency (MHz)	Actual Frequency (MHz)	PPM
CPUCLK	66.67	66.51	-2346
CPUCLK	75.0	75.0	0
CPUCLK	83.33	83.14	-2346
CPUCLK	100.0	99.77	-2346
USBCLK	48.0	48.01	167

CPU and PCI Clock Driver Strengths

- Matched impedances on both rising and falling edges on the output drivers
- Output impedance: 25Ω (typical) measured at 1.5V

Power Management Logic^[4] - Active when MODE pin is held 'LOW'

CPU_STOP	PCI_STOP	PWR_DWN	CPUCLK	PCICLK	PCICLK_F	Other Clocks	Osc.	PLLs
X	X	0	Low	Low	Stopped	Stopped	Off	Off
0	0	1	Low	Low	Running	Running	Running	Running
0	1	1	Low	33/30 MHz	Running	Running	Running	Running
1	0	1	66/75/83/100MHz	Low	Running	Running	Running	Running
1	1	1	66/75/83/100MHz	30/33.3 MHz	Running	Running	Running	Running

Serial Configuration Map

- The Serial bits will be read by the clock driver in the following order:

Byte 0 - Bits 7, 6, 5, 4, 3, 2, 1, 0

Byte 1 - Bits 7, 6, 5, 4, 3, 2, 1, 0

.

.

Byte N - Bits 7, 6, 5, 4, 3, 2, 1, 0

- Reserved and unused bits should be programmed to "0".
- I²C Address for the CY2283 is:

A6	A5	A4	A3	A2	A1	A0	R/W
1	1	0	1	0	0	1	----

Byte 0: Functional and Frequency Select Clock Register (1 = Enable, 0 = Disable)

Bit	Pin #	Description	
Bit 7	--	(Reserved) drive to '0'	
Bit 6	--	(Reserved) drive to '0'	
Bit 5	--	(Reserved) drive to '0'	
Bit 4	--	(Reserved) drive to '0'	
Bit 3	--	(Reserved) drive to '0'	
Bit 2	--	(Reserved) drive to '0'	
Bit 1	--	Bit 1	Bit 0
Bit 0	--	1	1 - Three-State
		1	0 - N/A
		0	1 - Testmode
		0	0 - Normal Operation

Select Functions

Functional Description	Outputs						AGP
	CPU	PCI, PCI_F	SDRAM	Ref	IOAPIC	USBCLK	
Three-State	Hi-Z	Hi-Z	Hi-Z	Hi-Z	Hi-Z	Hi-Z	Hi-Z
Test Mode ^[6]	TCLK/2 ^[5]	TCLK/4	TCLK/2	TCLK	TCLK	TCLK/2	TCLK/2

Notes:

- AGP clocks are free-running and stop only when the PWR_DWN pin is asserted. The frequency of the AGP clocks is as shown in the Function Table.
- TCLK supplied on the XTALIN pin in Test Mode.
- Valid only for SEL1=0.

**Byte 1: CPU Active/Inactive Register
(1 = Active, 0 = Inactive), Default = Active**

Bit	Pin #	Description
Bit 7	47	USBCLK
Bit 6	N/A	(Reserved) drive to '0'
Bit 5	N/A	(Reserved) drive to '0'
Bit 4	N/A	Not used - drive to '0'
Bit 3	40	CPUCLK3 (Active/Inactive)
Bit 2	41	CPUCLK2 (Active/Inactive)
Bit 1	43	CPUCLK1 (Active/Inactive)
Bit 0	44	CPUCLK0 (Active/Inactive)

**Byte 2: PCI Active/Inactive Register
(1 = Active, 0 = Inactive), Default = Active**

Bit	Pin #	Description
Bit 7	--	(Reserved) drive to '0'
Bit 6	7	PCICLK_F (Active/Inactive)
Bit 5	15	AGP1 (Active/Inactive)
Bit 4	14	AGP0 (Active/Inactive)
Bit 3	12	PCICLK3 (Active/Inactive)
Bit 2	11	PCICLK2 (Active/Inactive)
Bit 1	10	PCICLK1 (Active/Inactive)
Bit 0	8	PCICLK0 (Active/Inactive)

**Byte 3: SDRAM Active/Inactive Register
(1 = Active, 0 = Inactive), Default = Active**

Bit	Pin #	Description
Bit 7	28	SDRAM7 (Active/Inactive)
Bit 6	29	SDRAM6 (Active/Inactive)
Bit 5	31	SDRAM5 (Active/Inactive)
Bit 4	32	SDRAM4 (Active/Inactive)
Bit 3	34	SDRAM3 (Active/Inactive)
Bit 2	35	SDRAM2 (Active/Inactive)
Bit 1	37	SDRAM1 (Active/Inactive)
Bit 0	38	SDRAM0 (Active/Inactive)

**Byte 4: SDRAM Active/Inactive Register
(1 = Active, 0 = Inactive), Default = Active**

Bit	Pin #	Description
Bit 7	N/A	Not used - drive to '0'
Bit 6	N/A	Not used - drive to '0'
Bit 5	N/A	Not used - drive to '0'
Bit 4	N/A	Not used - drive to '0'
Bit 3	17	SDRAM11
Bit 2	18	SDRAM10
Bit 1	20	SDRAM9
Bit 0	21	SDRAM8

**Byte 5: Peripheral Active/Inactive Register
(1 = Active, 0 = Inactive), Default = Active**

Bit	Pin #	Description
Bit 7	N/A	(Reserved) drive to '0'
Bit 6	N/A	(Reserved) drive to '0'
Bit 5	N/A	(Reserved) drive to '0'
Bit 4	N/A	(Reserved), drive to '0'
Bit 3	N/A	(Reserved) drive to '0'
Bit 2	N/A	(Reserved) drive to '0'
Bit 1	N/A	(Reserved) drive to '0'
Bit 0	2	REF0 (Active/Inactive)

Byte 6: Reserved, for future use

Maximum Ratings

(Above which the useful life may be impaired. For user guidelines, not tested.)

Supply Voltage -0.5 to +7.0V
 Input Voltage -0.5V to $V_{DD}+0.5$

Storage Temperature (Non-Condensing) ... -65°C to +150°C
 Max. Soldering Temperature (10 sec) +260°C
 Junction Temperature +150°C
 Package Power Dissipation 1W
 Static Discharge Voltage >2000V
 (per MIL-STD-883, Method 3015, like V_{DD} pins tied together)

Operating Conditions^[7]

Parameter	Description	Min.	Max.	Unit
AV_{DD}, V_{DDQ3}	Analog and Digital Supply Voltage	3.135	3.465	V
V_{DDCPU}	CPU Supply Voltage	2.375 3.135	2.9 3.465	V
T_A	Operating Temperature, Ambient	0	70	°C
C_L	Max. Capacitive Load on CPUCLK, USBCLK, IOAPIC PCICLK, AGP, SDRAM REF0	10 20 20	20 30 45	pF
$f_{(REF)}$	Reference Frequency, Oscillator Nominal Value	14.318	14.318	MHz

Electrical Characteristics Over the Operating Range

Parameter	Description	Test Conditions	Min.	Max.	Unit
V_{IH}	High-level Input Voltage	Except Crystal Inputs	2.0		V
V_{IL}	Low-level Input Voltage	Except Crystal Inputs		0.8	V
V_{ILic}	Low-level Input Voltage	I ² C inputs only		0.7	V
V_{OH}	High-level Output Voltage	$V_{DDCPU} = V_{DDQ2} = 2.375V$ $I_{OH} = 16\text{ mA}$ CPUCLK $I_{OH} = 18\text{ mA}$ IOAPIC	2.0		V
V_{OL}	Low-level Output Voltage	$V_{DDCPU} = V_{DDQ2} = 2.375V$ $I_{OL} = 27\text{ mA}$ CPUCLK $I_{OL} = 29\text{ mA}$ IOAPIC		0.4	V
V_{OH}	High-level Output Voltage	$V_{DDQ3}, AV_{DD}, V_{DDCPU} = 3.135V$ $I_{OH} = 16\text{ mA}$ CPUCLK $I_{OH} = 36\text{ mA}$ SDRAM $I_{OH} = 32\text{ mA}$ PCICLK $I_{OH} = 26\text{ mA}$ USBCLK $I_{OH} = 36\text{ mA}$ REF0	2.4		V
V_{OL}	Low-level Output Voltage	$V_{DDQ3}, AV_{DD}, V_{DDCPU} = 3.135V$ $I_{OL} = 27\text{ mA}$ CPUCLK $I_{OL} = 29\text{ mA}$ SDRAM $I_{OL} = 26\text{ mA}$ PCICLK $I_{OL} = 21\text{ mA}$ USBCLK $I_{OL} = 29\text{ mA}$ REF0		0.4V	V
I_{IH}	Input High Current	$V_{IH} = V_{DD}$	-10	+10	µA
I_{IL}	Input Low Current	$V_{IL} = 0V$		10	µA
I_{OZ}	Output Leakage Current	Three-state	-10	+10	µA
I_{DD}	Power Supply Current ^[8]	$V_{DD} = 3.465V, V_{IN} = 0$ or V_{DD} , Loaded Outputs, CPU clocks = 66.67 MHz		300	mA
I_{DD}	Power Supply Current ^[8]	$V_{DD} = 3.465V, V_{IN} = 0$ or V_{DD} , Unloaded Outputs		120	mA
I_{DDS}	Power-down Current	Current draw in power-down state		500	µA

Notes:

7. Electrical parameters are guaranteed with these operating conditions.
8. Power supply current will vary with number of outputs that are running.

Switching Characteristics for CY2283-1^[9, 10]

Parameter	Output	Description	Test Conditions	Min.	Typ.	Max.	Unit
t ₁	All	Output Duty Cycle ^[11]	t ₁ = t _{1A} ÷ t _{1B}	45	50	55	%
t ₂	CPUCLK	CPU Clock Rising and Falling Edge Rate	Between 0.4V and 2.0V, V _{DDCPU} = 2.5V Between 0.4V and 2.4V, V _{DDCPU} = 3.3V	0.75		4.0	V/ns
t ₂	AGP, REF0	AGP, REF0 Clock Rising and Falling Edge Rate	Between 0.4V and 2.4V	0.85		4.0	V/ns
t ₂	PCI	PCI Rising and Falling Edge Rate	Between 0.4V and 2.4V	0.85		4.0	V/ns
t ₃	CPUCLK	CPU Clock Rise Time	Between 0.4V and 2.0V, V _{DDCPU} = 2.5V Between 0.4V and 2.4V, V _{DDCPU} = 3.3V	0.4 0.5		2.13 2.67	ns
t ₄	CPUCLK	CPU Clock Fall Time	Between 2.0V and 0.4V, V _{DDCPU} = 2.5V Between 2.4V and 0.4V, V _{DDCPU} = 3.3V	0.4 0.5		2.13 2.67	ns
t ₅	CPUCLK	CPU-CPU Clock Skew	Measured at 1.25V, V _{DDCPU} = 2.5V Measured at 1.5V, V _{DDCPU} = 3.3V		100	500	ps
t ₆	CPUCLK, PCICLK	CPU-PCI Clock Skew	Measured at 1.25V for 2.5V clocks, and at 1.5V for 3.3V clocks	2.5	3.5	5.5	ns
t ₈	PCICLK, PCICLK	PCI-PCI Clock Skew	Measured at 1.5V			500	ps
t ₉	PCICLK, AGP	PCI-AGP Clock Skew	Measured at 1.5V			1,200	ps
t ₁₀	CPUCLK	Cycle-Cycle Clock Jitter	Measured at 1.25V for 2.5V clocks, and at 1.5V for 3.3V clocks			500	ps
t ₁₀	PCICLK	Cycle-Cycle Clock Jitter	Measured at 1.5V			750	ps
t ₁₀	AGP	Cycle-Cycle Clock Jitter	Measured at 1.5V			800	ps
t ₁₁	CPUCLK, PCICLK, AGP	Power-up Time	CPU, PCI, AGP clock stabilization from power-up			3	ms

Notes:

9. Guaranteed by Design and Characterization, not 100% tested in production.
10. Device characterized and parameters guaranteed with SDRAM outputs turned off. All other outputs at maximum load.
11. Duty cycle is measured at 1.5V when V_{DD} = 3.3V. When V_{DDCPU} = 2.5V, CPUCLK duty cycle is measured at 1.25V.

Switching Characteristics for CY2283-2

Parameter	Output	Description	Test Conditions	Min.	Typ.	Max.	Unit
t ₁	All	Output Duty Cycle	t ₁ = t _{1A} ÷ t _{1B}	TBD	TBD	TBD	%
t ₂	CPUCLK	CPU Clock Rising and Falling Edge Rate	Between 0.4V and 2.0V, V _{DDCPU} = 2.5V Between 0.4V and 2.4V, V _{DDCPU} = 3.3V	TBD	TBD	TBD	V/ns
t ₂	SDRAM, AGP, REF0	SDRAM, AGP, REF0 Clock Rising and Falling Edge Rate	Between 0.4V and 2.4V	TBD	TBD	TBD	V/ns
t ₂	PCI	PCI Rising and Falling Edge Rate	Between 0.4V and 2.4V	TBD	TBD	TBD	V/ns
t ₃	CPUCLK	CPU Clock Rise Time	Between 0.4V and 2.0V, V _{DDCPU} = 2.5V Between 0.4V and 2.4V, V _{DDCPU} = 3.3V	TBD	TBD	TBD	ns
t ₄	CPUCLK	CPU Clock Fall Time	Between 2.0V and 0.4V, V _{DDCPU} = 2.5V Between 2.4V and 0.4V, V _{DDCPU} = 3.3V	TBD	TBD	TBD	ns
t ₅	CPUCLK	CPU-CPU Clock Skew	Measured at 1.25V, V _{DDCPU} = 2.5V Measured at 1.5V, V _{DDCPU} = 3.3V	TBD	TBD	TBD	ps
t ₆	CPUCLK, PCICLK	CPU-PCI Clock Skew	Measured at 1.25V for 2.5V clocks, and at 1.5V for 3.3V clocks	TBD	TBD	TBD	ns
t ₇	CPUCLK, SDRAM	CPU-SDRAM Clock Skew	Measured at 1.25V for 2.5V clocks, and at 1.5V for 3.3V clocks	TBD	TBD	TBD	ps
t ₈	PCICLK, PCICLK	PCI-PCI Clock Skew	Measured at 1.5V	TBD	TBD	TBD	ps
t ₉	PCICLK, AGP	PCI-AGP Clock Skew	Measured at 1.5V	TBD	TBD	TBD	ps
t ₁₀	CPUCLK, SDRAM	Cycle-Cycle Clock Jitter	Measured at 1.25V for 2.5V clocks, and at 1.5V for 3.3V clocks	TBD	TBD	TBD	ps
t ₁₀	PCICLK	Cycle-Cycle Clock Jitter	Measured at 1.5V	TBD	TBD	TBD	ps
t ₁₀	AGP	Cycle-Cycle Clock Jitter	Measured at 1.5V	TBD	TBD	TBD	ps
t ₁₁	CPUCLK, PCICLK, AGP, SDRAM	Power-up Time	CPU, PCI, AGP, and SDRAM clock stabilization from power-up	TBD	TBD	TBD	ms

Timing Requirement for the I²C Bus

Parameter	Description	Min.	Max.	Unit
t ₁₂	SCLK Clock Frequency	0	100	kHz
t ₁₃	Time the bus must be free before a new transmission can start	4.7		μs
t ₁₄	Hold time start condition. After this period the first clock pulse is generated.	4		μs
t ₁₅	The LOW period of the clock	4.7		μs
t ₁₆	The HIGH period of the clock	4		μs
t ₁₇	Set-up time for start condition. (Only relevant for a repeated start condition.)	4.7		μs
t ₁₈	Hold time DATA for CBUS compatible masters for I ² C devices	5 0		μs
t ₁₉	DATA input set-up time	250		ns
t ₂₀	Rise time of both SDATA and SCLK inputs		1	μs
t ₂₁	Fall time of both SDATA and SCLK inputs		300	ns
t ₂₂	Set-up time for stop condition	4.0		μs

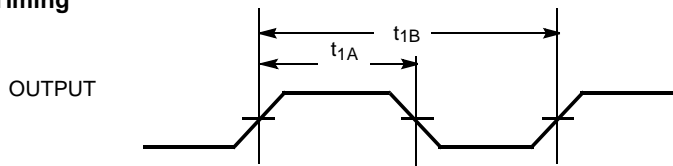
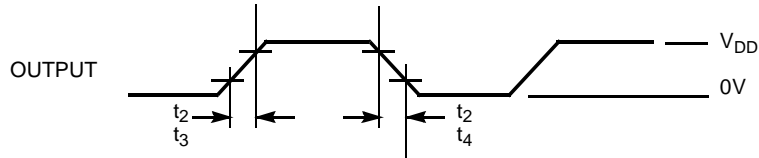
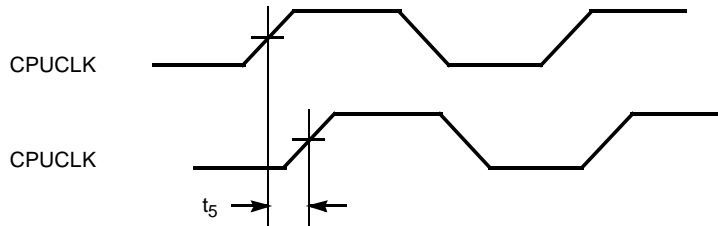
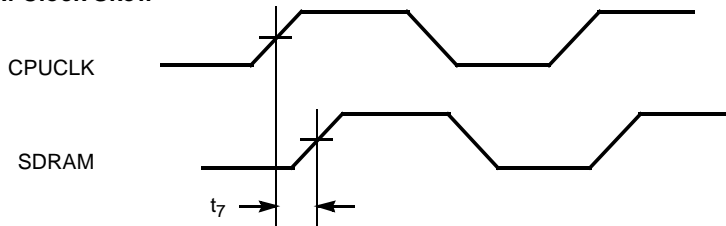
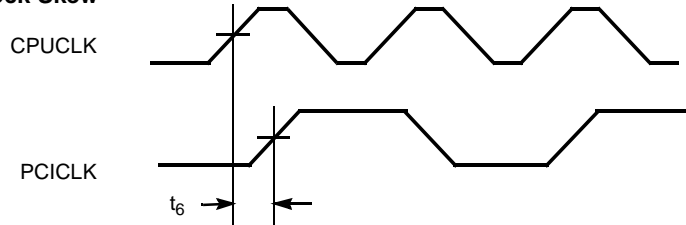
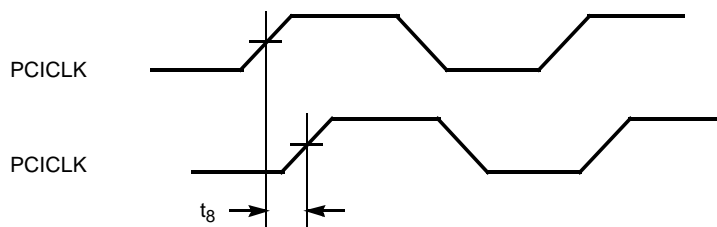
Switching Waveforms
Duty Cycle Timing

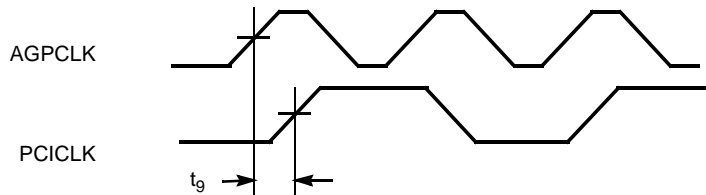
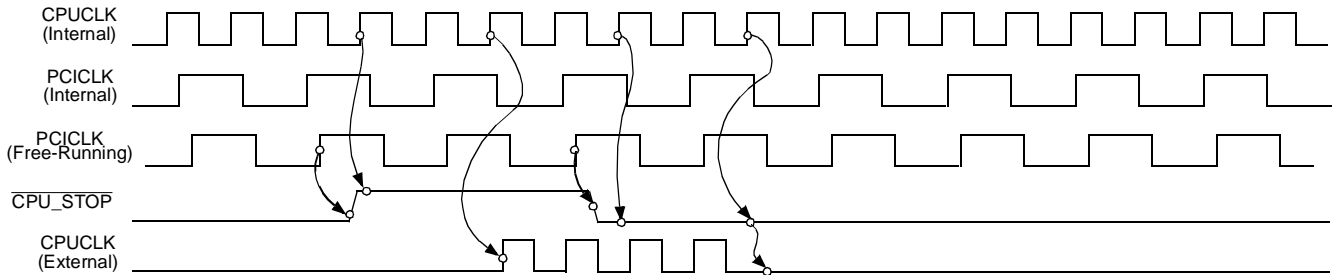
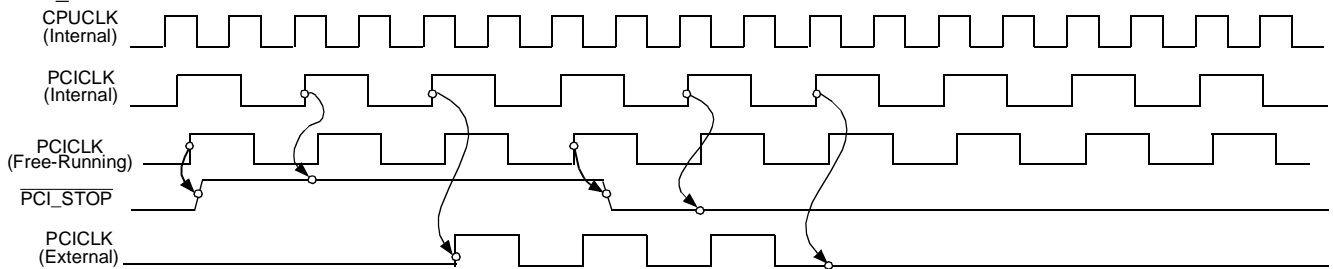
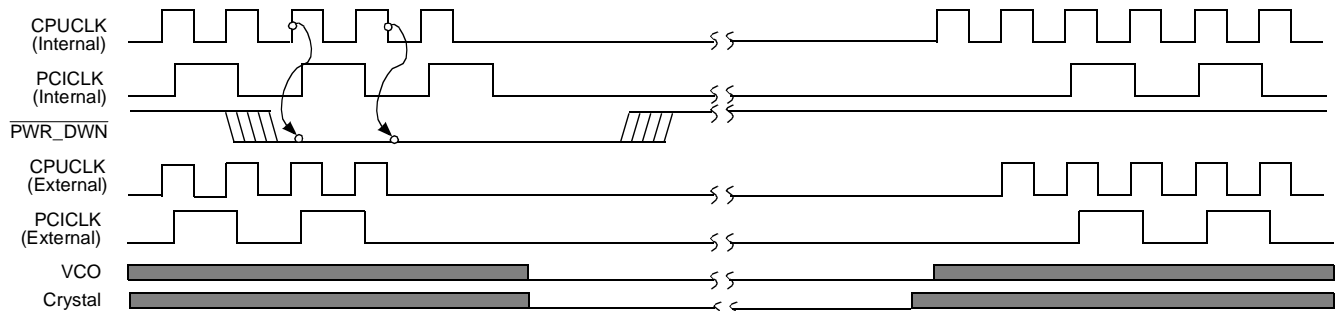
All Outputs Rise/Fall Time

CPU-CPU Clock Skew

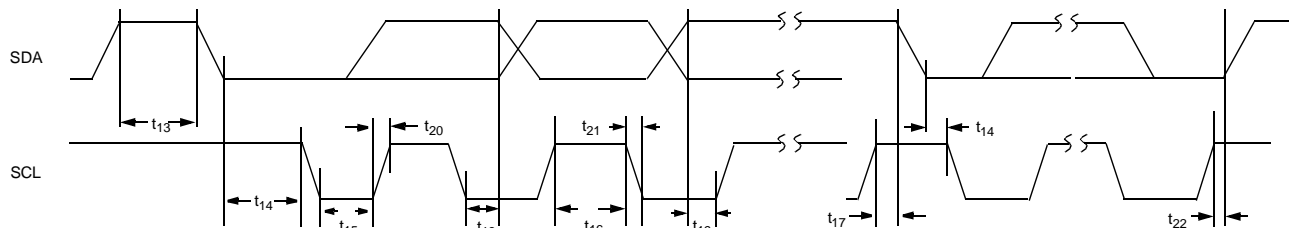
CPU-SDRAM Clock Skew

CPU-PCI Clock Skew

PCI-PCI Clock Skew

Switching Waveforms (continued)
AGP-PCI Clock Skew

CPU_STOP^[12, 13]

PCI_STOP^[14, 15]

PWR_DOWN

Shaded section on the VCO and Crystal waveforms indicates that the VCO and crystal oscillator are active, and there is a valid clock.

Timing Requirements for the I²C Bus

Notes:

12. CPUCLK on and CPUCLK off latency is 2 or 3 CPUCLK cycles.
13. CPU_STOP may be applied asynchronously. It is synchronized internally.
14. PCICLK on and PCICLK off latency is 1 rising edge of the external PCICLK.
15. PCI_STOP may be applied asynchronously. It is synchronized internally.

Application Circuit

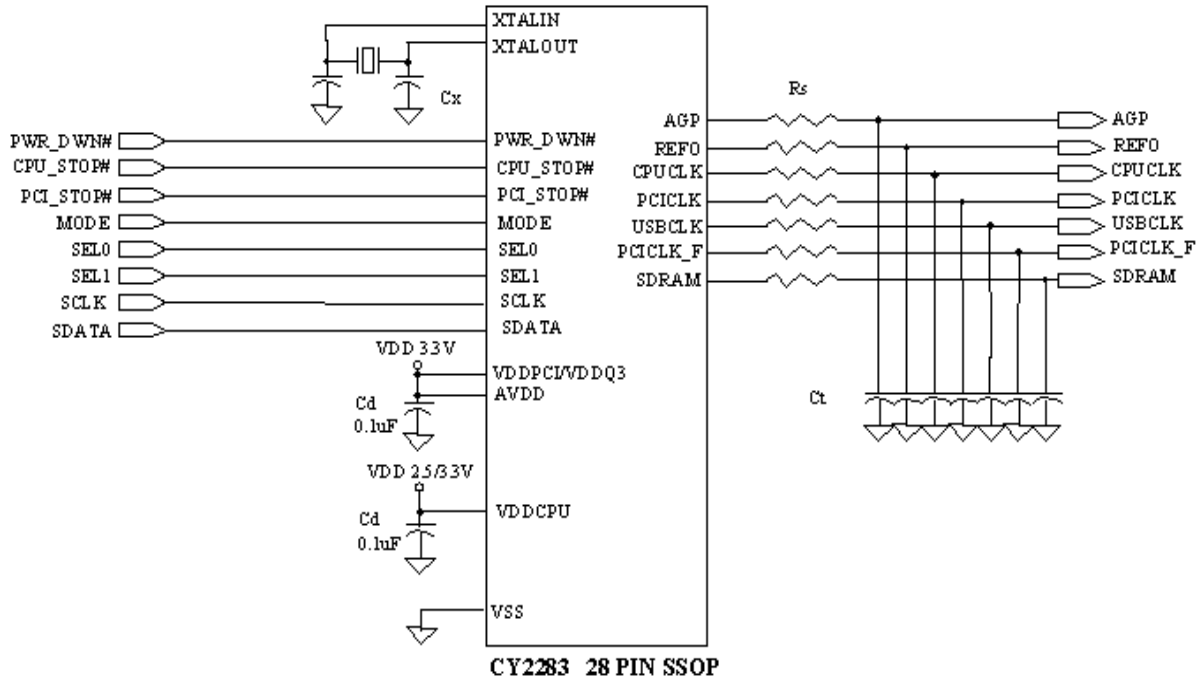
Clock traces must be terminated with either series or parallel termination, as they are normally done



Cd = DECOUPLING CAPACITORS
 Ct = OPTIONAL EMI-REDUCING CAPACITORS
 Cx = OPTIONAL LOAD MATCHING CAPACITOR
 Rs = SERIES TERMINATING RESISTORS

Summary

- A parallel-resonant crystal should be used as the reference to the clock generator. The operating frequency and C_{LOAD} of this crystal should be as specified in the data sheet. Optional trimming capacitors may be needed if a crystal with a different C_{LOAD} is used. Footprints must be laid out for flexibility.
- Surface mount, low-ESR, ceramic capacitors should be used for filtering. Typically, these capacitors have a value of 0.1 μ F. In some cases, smaller value capacitors may be required.
- The value of the series terminating resistor satisfies the following equation, where R_{trace} is the loaded characteristic impedance of the trace, R_{out} is the output impedance of the clock generator (specified in the data sheet), and R_{series} is the series terminating resistor.

$$R_{series} \geq R_{trace} - R_{out}$$

- Footprints must be laid out for optional EMI-reducing capacitors, which should be placed as close to the terminating resistor as is physically possible. Typical values of these capacitors range from 4.7 pF to 22 pF.
- A Ferrite Bead **may** be used to isolate the Board V_{DD} from the clock generator V_{DD} island. Ensure that the Ferrite Bead offers greater than 50 Ω impedance at the clock frequency, under loaded DC conditions. Please refer to the application note "Layout and Termination Techniques for Cypress Clock Generators" for more details.
- If a Ferrite Bead is used, a 10 μ F– 22 μ F tantalum bypass capacitor should be placed close to the Ferrite Bead. This capacitor prevents power supply droop during current surges.

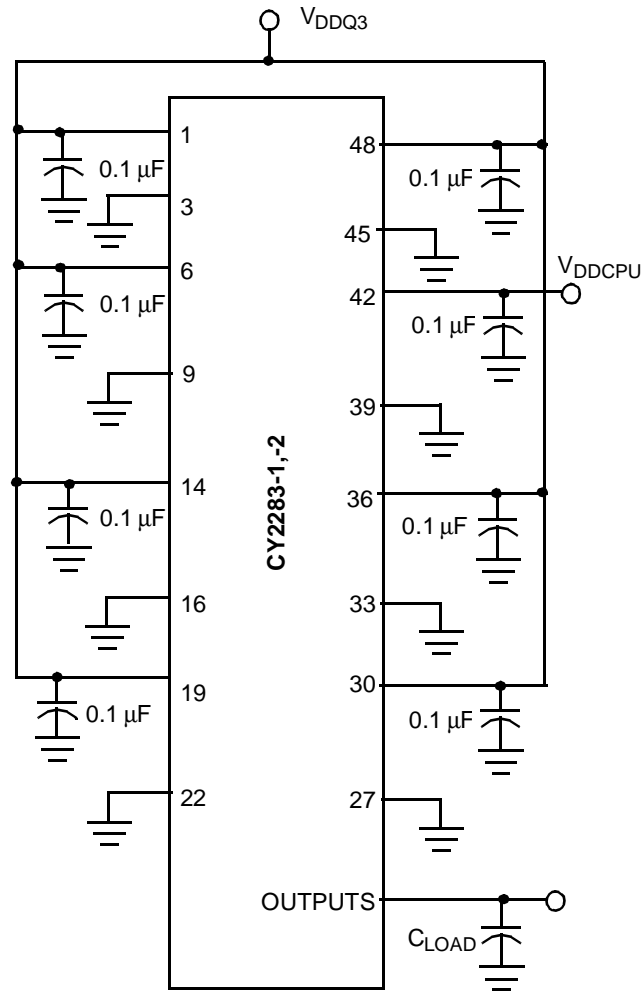
Test Circuit

Note: All Capacitors must be placed as close to the pins as is possible

Ordering Information

Ordering Code	Package Name	Package Type	Operating Range
CY2283PVC-1	O48	48-Pin SSOP	Commercial
CY2283PVC-2	O48	48-Pin SSOP	Commercial

Document #: 38-00685-A

Intel and Pentium are registered trademarks of Intel Corporation. I²C is a trademark of Philips Corporation.

Package Diagram

48-Lead Shrunken Small Outline Package O48

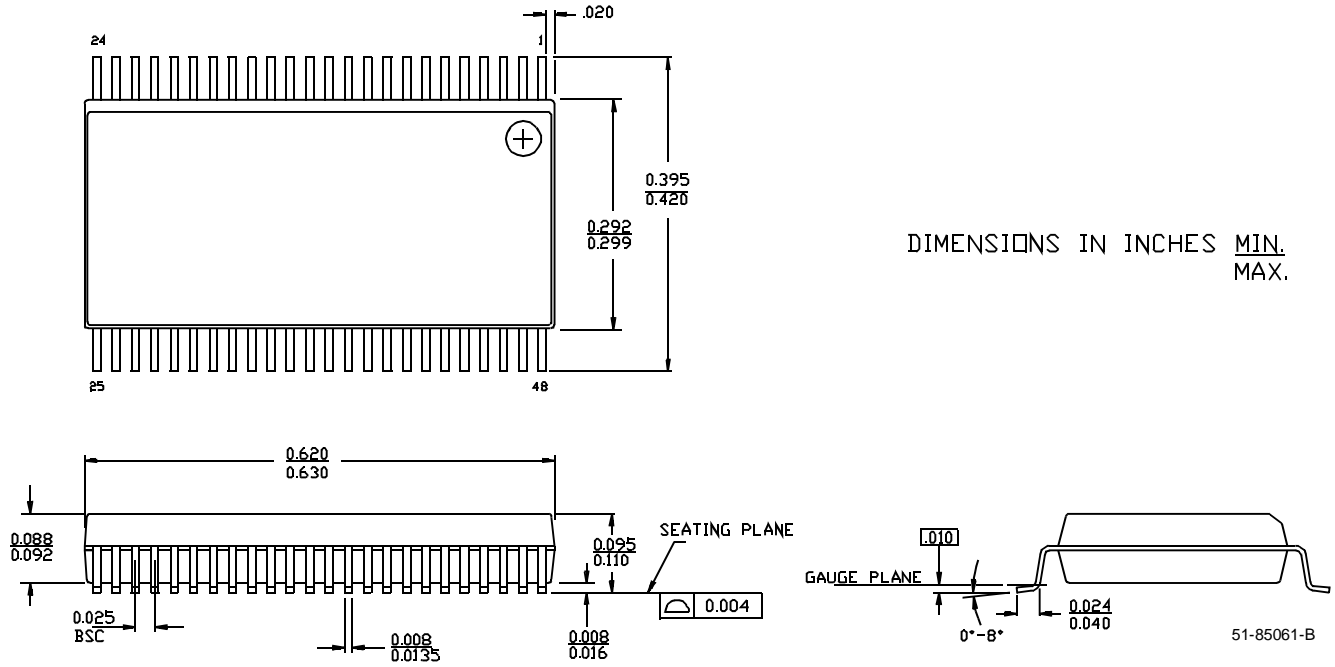

© Cypress Semiconductor Corporation, 1998. The information contained herein is subject to change without notice. Cypress Semiconductor Corporation assumes no responsibility for the use of any circuitry other than circuitry embodied in a Cypress Semiconductor product. Nor does it convey or imply any license under patent or other rights. Cypress Semiconductor does not authorize its products for use as critical components in life-support systems where a malfunction or failure may reasonably be expected to result in significant injury to the user. The inclusion of Cypress Semiconductor products in life-support systems application implies that the manufacturer assumes all risk of such use and in doing so indemnifies Cypress Semiconductor against all charges.