

DATA SHEET

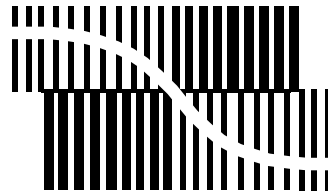

BITSTREAM CONVERSION

UDA1338H Multichannel audio coder-decoder

Preliminary specification
Supersedes data of 2002 May 23

2002 Nov 21

Multichannel audio coder-decoder**UDA1338H**

CONTENTS	11	REGISTER MAPPING
1	11.1	Address mapping
1.1	11.2	Register mapping
1.2	11.3	System settings
1.3	11.4	Audio ADC and DAC subsystem settings
1.4	11.5	Voice ADC system settings
2	11.6	Status output register (read only)
3	11.7	DAC channel selection
4	11.8	DAC features settings
5	11.9	DAC channel 1 to 6 settings
6	11.10	DAC mixing channel settings
7	11.11	Audio ADC 1 and ADC 2 input amplifier gain settings
8	11.12	Voice ADC gain settings
8.1	11.13	Supplemental settings 1
8.2	11.14	Supplemental settings 2
8.3	12	LIMITING VALUES
8.4	13	HANDLING
8.5	14	QUALITY SPECIFICATION
8.6	15	THERMAL CHARACTERISTICS
8.7	16	DC CHARACTERISTICS
8.8	17	AC CHARACTERISTICS
8.9	18	TIMING
8.10	19	PACKAGE OUTLINE
8.11	20	SOLDERING
8.12	20.1	Introduction to soldering surface mount packages
8.13	20.2	Reflow soldering
8.14	20.3	Wave soldering
9	20.4	Manual soldering
9.1	20.5	Suitability of surface mount IC packages for wave and reflow soldering methods
9.2	21	DATA SHEET STATUS
9.3	22	DEFINITIONS
9.4	23	DISCLAIMERS
9.5	24	PURCHASE OF PHILIPS I²C COMPONENTS
10		
10.1		
10.2		
10.3		
10.4		
10.5		
10.6		
10.7		
10.8		
10.9		
10.10		
10.11		
10.12		

Multichannel audio coder-decoder

UDA1338H

1 FEATURES**1.1 General**

- 2.7 to 3.6 V power supply
- 5 V tolerant digital inputs
- 24-bit data path
- Selectable control: via L3-bus or I²C-bus microcontroller interface
- Supports sample frequency ranges for:
 - Audio ADC: $f_s = 16$ to 100 kHz
 - Voice ADC: $f_s = 7$ to 50 kHz
 - Audio DAC: $f_s = 16$ to 200 kHz.
- Separate power control for ADC and DAC
- ADC plus integrated high-pass filter to cancel DC offset
- Integrated digital filter plus DAC
- Slave mode only applications
- Easy application.

1.2 Multiple format data interface

- Audio interface supports standard I²S-bus, MSB-justified, LSB-justified and two multichannel formats
- Voice interface supports I²S-bus and mono channel formats.

1.3 Digital sound processing

- Control via L3-bus or I²C-bus:
 - Channel independent digital logarithmic volume
 - Digital de-emphasis for $f_s = 32, 44.1, 48$ or 96 kHz
 - Soft or quick mute
 - Output signal polarity control.

1.4 Advanced audio configuration

- Inputs:
 - 4 single-ended audio inputs (2 × stereo) with programmable gain amplifiers
 - 1 single-ended voice input

4 ORDERING INFORMATION

TYPE NUMBER	PACKAGE		
	NAME	DESCRIPTION	VERSION
UDA1338H	QFP44	plastic quad flat package; 44 leads (lead length 1.3 mm); body 10 × 10 × 1.75 mm	SOT307-2

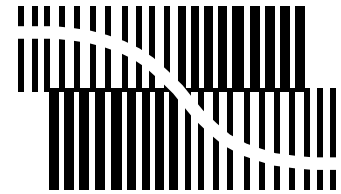

BITSTREAM CONVERSION

- Outputs:
 - 6 differential audio outputs (3 × stereo)
- DSD mode to support stereo DSD playback
- High linearity, wide dynamic range and low distortion
- DAC digital filter with selectable sharp or soft roll-off.

2 APPLICATIONS

- Excellently suitable for multichannel home audio-video application.

3 GENERAL DESCRIPTION

The UDA1338H is a single-chip consisting of 4 plus 1 analog-to-digital converters and 6 digital-to-analog converters with signal processing features employing bitstream conversion techniques. The multichannel configuration makes the device eminently suitable for use in digital audio equipment which incorporates surround feature.

The UDA1338H supports conventional 2 channels per line data transfer conformable to the I²S-bus format with word lengths of up to 24 bits, the MSB-justified format with word lengths of up to 24 bits and the LSB-justified format with word lengths of 16, 20 and 24 bits, as well as 4 to 6 channels per line transfer mode. The device also supports a combination of the MSB-justified output format and the LSB-justified input format. The UDA1338H has special sound processing features in the Direct Stream Digital (DSD) playback mode, de-emphasis, volume and mute which can be controlled via the L3-bus or I²C-bus interface.

Multichannel audio coder-decoder

UDA1338H

5 QUICK REFERENCE DATA

$V_{DDD} = V_{DDA(AD)} = V_{DDA(DA)} = 3.3\text{ V}$; $T_{\text{amb}} = 25\text{ °C}$; $R_L = 22\text{ k}\Omega$; all voltages referenced to ground (pins V_{SS}); unless otherwise specified.

SYMBOL	PARAMETER	CONDITIONS	MIN.	TYP.	MAX.	UNIT
Supplies						
$V_{DDA(AD)}$	ADC analog supply voltage		2.7	3.3	3.6	V
$V_{DDA(DA)}$	DAC analog supply voltage		2.7	3.3	3.6	V
V_{DDD}	digital supply voltage		2.7	3.3	3.6	V
$I_{DDA(AD)}$	ADC analog supply current	$f_{\text{ADC}} = 48\text{ kHz}$	–	30	–	mA
$I_{DDA(DA)}$	DAC analog supply current	$f_{\text{DAC}} = 48\text{ kHz}$	–	20	–	mA
I_{DDD}	digital supply current	$f_{\text{ADC}} = f_{\text{DAC}} = 48\text{ kHz}$; $f_{\text{VOICE}} = 48\text{ kHz}$	–	31	–	mA
$I_{DDD(\text{pd})}$	digital supply current in Power-down mode	audio and voice ADCs power-down	–	tbf	–	mA
		DAC power-down	–	tbf	–	mA
T_{amb}	ambient temperature		–20	–	+85	°C
Audio analog-to-digital converter						
D_0	digital output level	at 0 dB setting; 900 mV (RMS) input; notes 1 and 2	–2.5	–1.2	–0.7	dB
(THD+N)/S	total harmonic distortion-plus-noise to signal ratio	at –1 dBFS	–	–90	–83	dB
		at –60 dBFS; A-weighted	–	–40	–34	dB
S/N	signal-to-noise ratio	code = 0; A-weighted	94	100	–	dB
α_{cs}	channel separation		–	100	–	dB
Digital-to-analog converter						
DIFFERENTIAL MODE						
$V_{o(\text{rms})}$	output voltage (RMS value)	at 0 dBFS digital input	1.9	2.0	2.1	V
(THD+N)/S	total harmonic distortion-plus-noise to signal ratio	at 0 dBFS	–	–100	–93	dB
		at –60 dBFS; A-weighted	–	–50	–45	dB
S/N	signal-to-noise ratio	code = 0; A-weighted	107	114	–	dB
α_{cs}	channel separation		–	117	–	dB
SINGLE-ENDED MODE						
$V_{o(\text{rms})}$	output voltage (RMS value)	at 0 dBFS digital input	–	1.0	–	V
(THD+N)/S	total harmonic distortion-plus-noise to signal ratio	at 0 dBFS	–	–90	–	dB
		at –60 dBFS; A-weighted	–	–45	–	dB
S/N	signal-to-noise ratio	code = 0; A-weighted	–	110	–	dB
α_{cs}	channel separation		–	114	–	dB

Notes

1. The input voltage can be up to 2 V (RMS) when the current through the ADC input pin is limited to approximately 1 mA by using a series resistor.
2. The input voltage to the ADC scales proportionally with the power supply voltage.

Multichannel audio coder-decoder

UDA1338H

6 BLOCK DIAGRAM

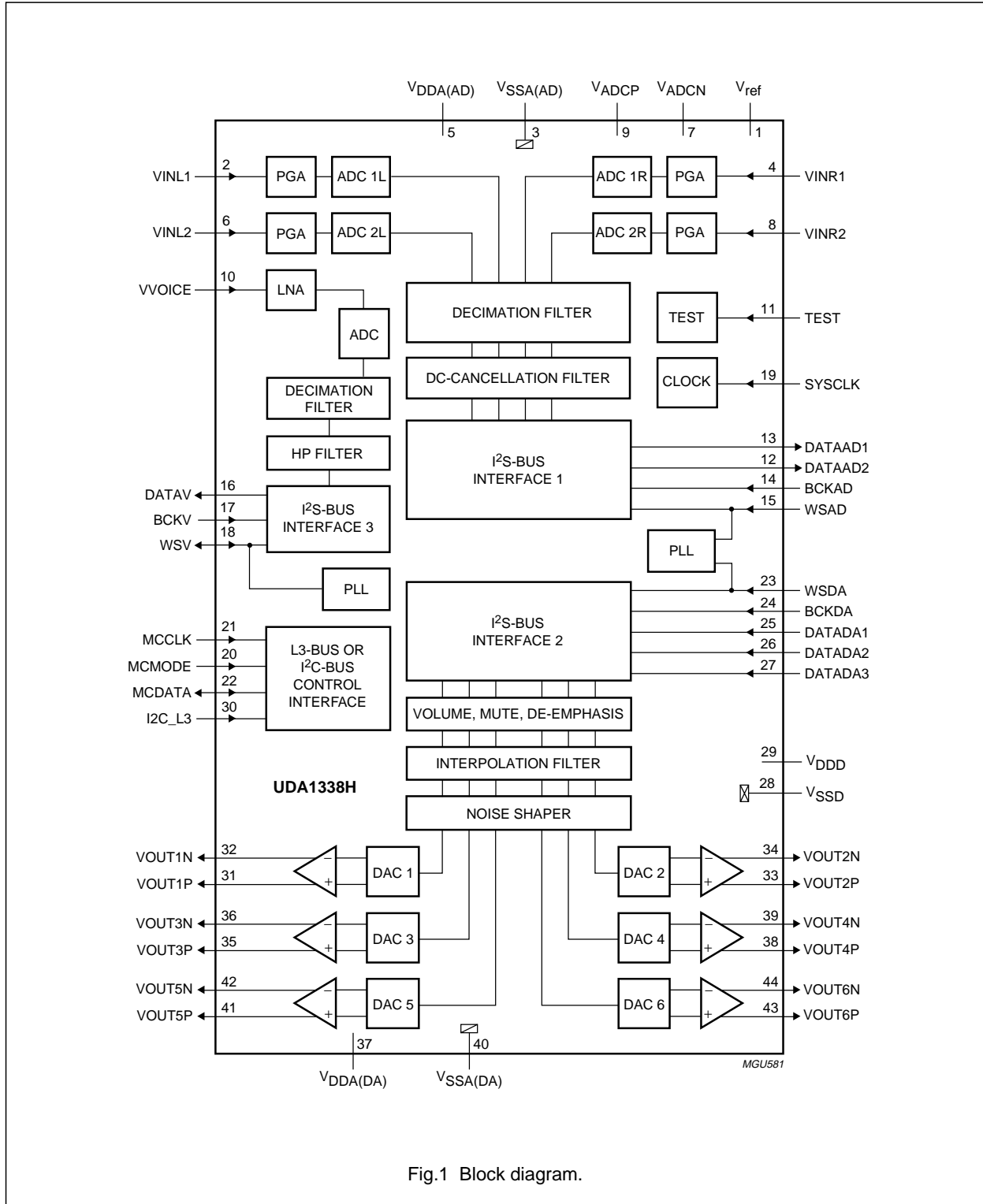

Fig.1 Block diagram.

Multichannel audio coder-decoder

UDA1338H

7 PINNING

SYMBOL	PIN	TYPE ⁽¹⁾	DESCRIPTION
V _{ref}	1	AIO	ADC reference voltage
VINL1	2	AIO	ADC 1 input left
V _{SSA(AD)}	3	AGND	ADC analog ground
VINR1	4	AIO	ADC 1 input right
V _{DDA(AD)}	5	AS	ADC analog supply voltage
VINL2	6	AIO	ADC 2 input left
V _{ADCN}	7	AIO	ADC reference voltage N
VINR2	8	AIO	ADC 2 input right
V _{ADCP}	9	AIO	ADC reference voltage P
VVOICE	10	AIO	voice ADC input
TEST	11	DID	test input; must be connected to digital ground (V _{SSD}) in application
DATAAD2	12	DO	ADC 2 data output
DATAAD1	13	DO	ADC 1 data output
BCKAD	14	DIS	ADC bit clock input
WSAD	15	DI	ADC word select input
DATAV	16	DO	voice data output
BCKV	17	DIS	voice bit clock input
WSV	18	DIO	voice word select input or output
SYCLK	19	DIS	system clock input: 256f _s , 384f _s , 512f _s or 768f _s
MCMODE	20	DI	L3-bus L3MODE input or I ² C-bus DAC mute control input
MCCLK	21	DIS	L3-bus L3CLOCK input or I ² C-bus SCL input
MCDATA	22	IIC	L3-bus L3DATA input and output or I ² C-bus SDA input and output
WSDA	23	DI	DAC word select input
BCKDA	24	DIS	DAC bit clock input
DATADA1	25	DI	DAC channel 1 and channel 2 data input
DATADA2	26	DI	DAC channel 3 and channel 4 data input
DATADA3	27	DI	DAC channel 5 and channel 6 data input
V _{SSD}	28	DGND	digital ground

SYMBOL	PIN	TYPE ⁽¹⁾	DESCRIPTION
V _{DD}	29	DS	digital supply voltage
I2C_L3	30	DI	selection input for L3-bus or I ² C-bus control
VOUT1P	31	AIO	DAC 1 positive output
VOUT1N	32	AIO	DAC 1 negative output
VOUT2P	33	AIO	DAC 2 positive output
VOUT2N	34	AIO	DAC 2 negative output
VOUT3P	35	AIO	DAC 3 positive output
VOUT3N	36	AIO	DAC 3 negative output
V _{DDA(DA)}	37	AS	DAC analog supply voltage
VOUT4P	38	AIO	DAC 4 positive output
VOUT4N	39	AIO	DAC 4 negative output
V _{SSA(DA)}	40	AGND	DAC analog ground
VOUT5P	41	AIO	DAC 5 positive output
VOUT5N	42	AIO	DAC 5 negative output
VOUT6P	43	AIO	DAC 6 positive output
VOUT6N	44	AIO	DAC 6 negative output

Note

1. See Table 1.

Table 1 Pin types

TYPE	DESCRIPTION
AGND	analog ground
AIO	analog input and output
AS	analog supply
DGND	digital ground
DI	digital input
DID	digital input with internal pull-down resistor
DIO	digital input and output
DIS	digital Schmitt-triggered input
DO	digital output
DS	digital supply
IIC	input and open-drain output for I ² C-bus

Multichannel audio coder-decoder

UDA1338H

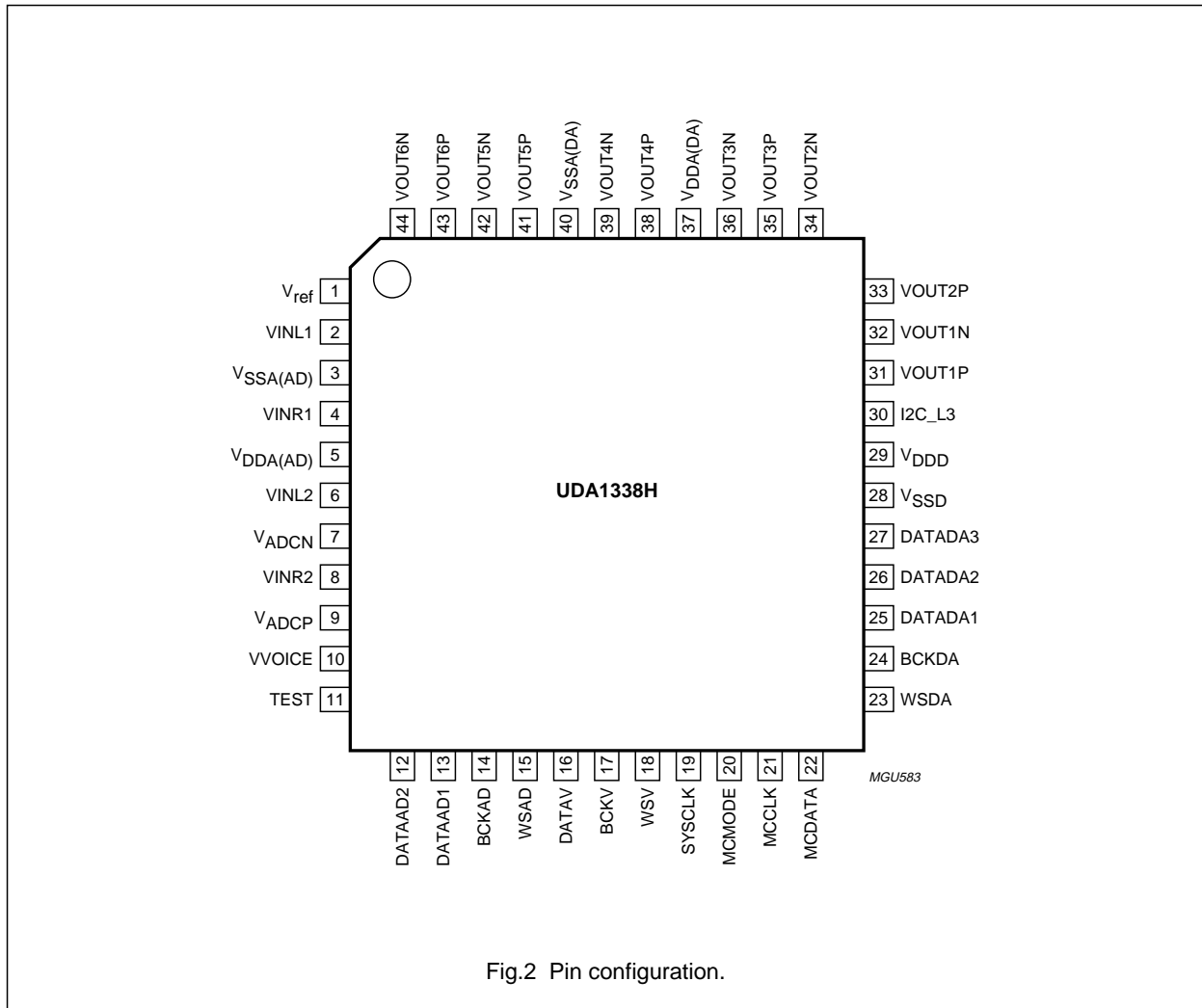

Fig.2 Pin configuration.

Multichannel audio coder-decoder

UDA1338H

8 FUNCTIONAL DESCRIPTION**8.1 System clock**

The UDA1338H operates in slave mode only; this means that in all applications the system must provide either the system clock (the bit clock for the voice ADC) or the word clock.

The audio ADC part, the voice ADC part and the DAC part can operate at different sampling frequencies (DAC-WS and ADC-WS modes) as well as a common frequency (SYSCLK, WSDA and DSD modes).

The voice ADC part supports a sampling frequency up to 50 kHz and the audio ADC supports a sampling frequency up to 100 kHz. The DAC sampling frequency range is extended up to 200 kHz with the range above 100 kHz being supported through 192 kHz sampling mode, which halves the oversampling ratio of SYSCLK and internal clocks.

The mode of operation of the audio and voice channels can be set via the L3-bus or I²C-bus microcontroller interface and are summarized in Tables 2 and 3.

When applied, the system clock must be locked in frequency to the corresponding digital interface clocks.

The voice ADC part can either receive or generate the WSV signal as shown in Table 3.

Table 2 Audio ADC and DAC operating clock mode

MODE	AUDIO ADC		AUDIO DAC	
	CLOCK	FREQUENCY	CLOCK	FREQUENCY
SYSCLK	SYSCLK	256f _s , 384f _s , 512f _s or 768f _s	SYSCLK	256f _s , 384f _s , 512f _s or 768f _s
			SYSCLK	128f _s , 192f _s , 256f _s or 384f _s ; 192 kHz sampling mode
DAC-WS	SYSCLK	256f _s , 384f _s , 512f _s or 768f _s	WSDA	1f _s
ADC-WS	WSAD	1f _s	SYSCLK	256f _s , 384f _s , 512f _s or 768f _s
			SYSCLK	128f _s , 192f _s , 256f _s or 384f _s ; 192 kHz sampling mode
WSDA	WSDA	1f _s	WSDA	1f _s
DSD	SYSCLK	44.1 kHz × 512	SYSCLK	44.1 kHz × 512

Table 3 Voice ADC operating clock mode

MODE	VOICE ADC	
	BIT CLOCK FREQUENCY (BCKV)	WORD SELECT (WSV)
WSV-in	input: 32f _s , 64f _s , 128f _s or 256f _s	input
WSV-out	input: 32f _s , 64f _s , 128f _s or 256f _s	output

Multichannel audio coder-decoder

UDA1338H

8.2 Audio analog-to-digital converter (audio ADC)

The audio analog-to-digital front-end of the UDA1338H consists of 4-channel single-ended Adds with programmable gain stage (from 0 to 24 dB with 3 dB steps), controlled via the microcontroller interface. Using the PGA feature, it is possible to accept an input signal of 900 mV (RMS) or 1.8 V (RMS) if an external resistor of 10 kΩ is used in series. The schematic of audio ADC front-end is shown in Fig.3.

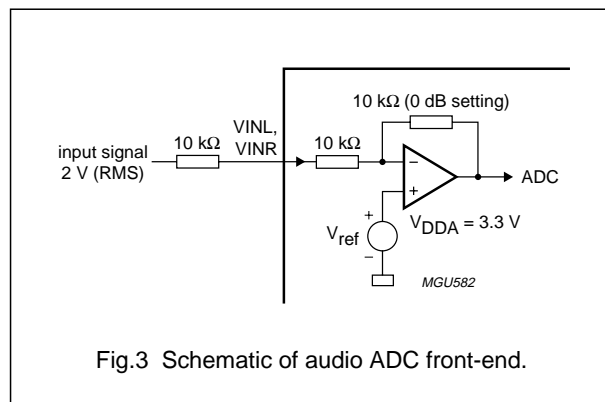

Fig.3 Schematic of audio ADC front-end.

8.3 Voice analog-to-digital converter (voice ADC)

The voice analog-to-digital front-end of the UDA1338H consists of a single-channel single-ended ADC with a fixed gain (26 dB) Low Noise Amplifier (LNA). Together with the digital variable gain amplification stage, the voice ADC provides optimal processing and reproduction of the microphone signal. The supported sampling frequency range is from 7 to 50 kHz. Power-down of the LNA and the ADC can be controlled separately.

8.4 Decimation filter of audio ADC

The decimation from $64f_s$ is performed in two stages.

The first stage realizes $\left(\frac{\sin x}{x}\right)^4$ characteristics with a

decimation factor of 8. The second stage consists of three half-band filters, each decimating by a factor of 2. The filter characteristics are shown in Table 4.

Table 4 Decimation filter characteristics (audio ADC)

ITEM	CONDITION	VALUE (dB)
Pass-band ripple	0 to $0.45f_s$	± 0.01
Pass-band droop	$0.45f_s$	-0.2
Stop band	$>0.55f_s$	-70
Dynamic range	0 to $0.45f_s$	>135

8.5 Decimation filter of voice ADC

The voice ADC decimation filter is realized with the combination of a Finite Impulse Response (FIR) filter and Infinite Impulse Response (IIR) filter for shorter group delay. The filter characteristics are shown in Table 5. During the power-on sequence, the output of the ADC is hard muted for a certain period. This hard-mute time can be chosen between 1024 and 2048 samples.

Table 5 Decimation filter characteristics (voice ADC)

ITEM	CONDITION	VALUE (dB)
Pass-band ripple	0 to $0.45f_s$	± 0.05
Pass-band droop	$0.45f_s$	-0.2
Stop band	$>0.55f_s$	-65
Dynamic range	0 to $0.45f_s$	>110

8.6 Interpolation filter of DAC

The digital interpolation filter interpolates from $1f_s$ to $128f_s$ (or to $64f_s$ in the 192 kHz sampling mode) by cascading FIR filters, and has two sets of filter coefficients for sharp and slow roll-off as given in Tables 6 and 7.

Table 6 Interpolation filter characteristics (sharp roll-off)

ITEM	CONDITION	VALUE (dB)
Pass-band ripple	0 to $0.45f_s$	± 0.002
Stop band	$>0.55f_s$	-75
Dynamic range	0 to $0.45f_s$	>135

Table 7 Interpolation filter characteristics (slow roll-off)

ITEM	CONDITION	VALUE (dB)
Pass-band ripple	0 to $0.22f_s$	± 0.002
Pass-band droop	$0.45f_s$	-3.1
Stop band	$>0.78f_s$	-94
Dynamic range	0 to $0.22f_s$	>135

8.7 Noise shaper of DAC

The 3rd-order noise shaper operates at either $128f_s$ or $64f_s$ (in the 192 kHz sampling mode), and converts the 24-bit input signal into a 5-bit signal stream. The noise shaper shifts in-band quantization noise to frequencies well above the audio band. This noise shaping technique enables high signal-to-noise ratios to be achieved.

Multichannel audio coder-decoder

UDA1338H

8.8 Digital mixer

The UDA1338H has 6 digital mixers inside the interpolator (see Fig.4). The ADC signals can be mixed with the I²S-bus input signals. The mixing of the ADC signals can be selected by the bits MIX[1:0].

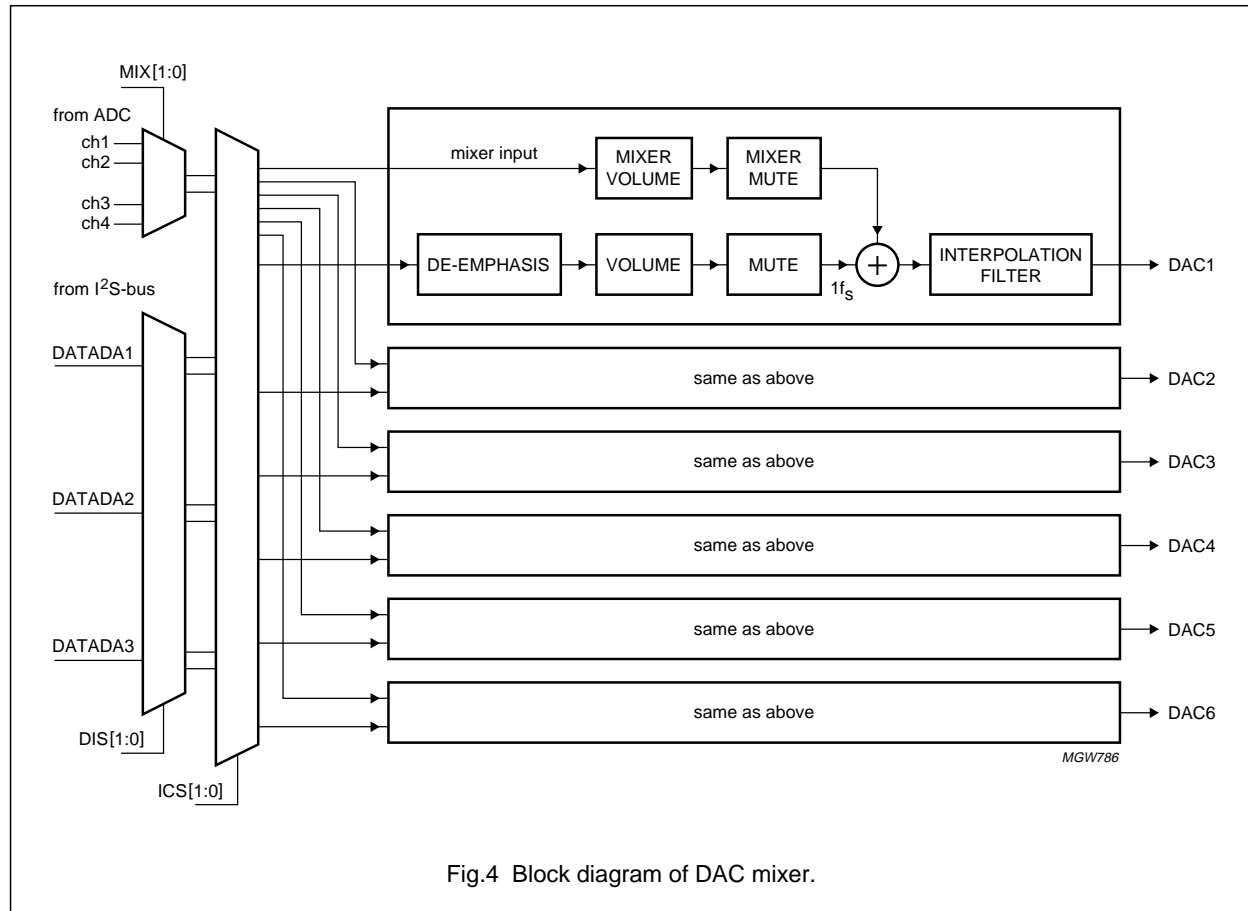

Fig.4 Block diagram of DAC mixer.

8.9 Audio digital-to-analog converters

The audio digital-to-analog front-end of the UDA1338H consists of 6-channel differential SDACs: an SDAC is a multi-bit DAC based upon switched resistors. To minimize data dependent modulation effects, a Dynamic Element Matching (DEM) algorithm scrambler circuit and DC current compensation circuit are implemented with the SDAC.

8.10 Power-on reset

The UDA1338H has an internal power-on reset circuit which initializes the device (see Fig.5). All the digital sound processing features and the system controlling features are set to their default values in the L3-bus and the I²C-bus modes.

The reset time (see Fig.6) is determined by an external capacitor which is connected between pin V_{ref} and ground. The reset time should be at least 250 μ s for $V_{ref} < 1.25$ V. When $V_{DDA(AD)}$ is switched off, the device will be reset again for $V_{ref} < 0.75$ V.

During the reset time, the system clock should be running.

Multichannel audio coder-decoder

UDA1338H

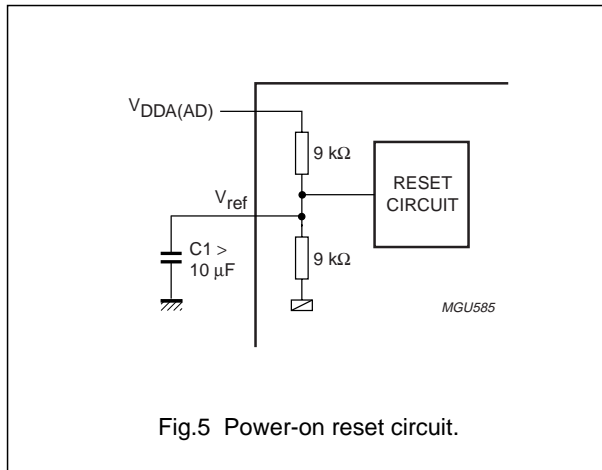
**8.11 Audio digital interface**

The following audio formats can be selected via the microcontroller interface:

- I²S-bus format with data word length of up to 24 bits
- MSB-justified format with data word length of up to 24 bits
- LSB-justified format with data word length of 16, 20 or 24 bits
- Multichannel formats with data word length of 20 or 24 bits. The used data lines are DATAAD1 and DATADA1 and the sampling frequency must be below 50 kHz.

The formats are illustrated in Figs 7 and 8.

8.12 Voice digital interface

The following voice formats can be selected via the microcontroller interface:

- I²S-bus format with data word length of up to 20 bits. The left and the right channels contain the same data.
- Mono channel format with data word length of up to 20 bits.

The formats are illustrated in Fig.9.

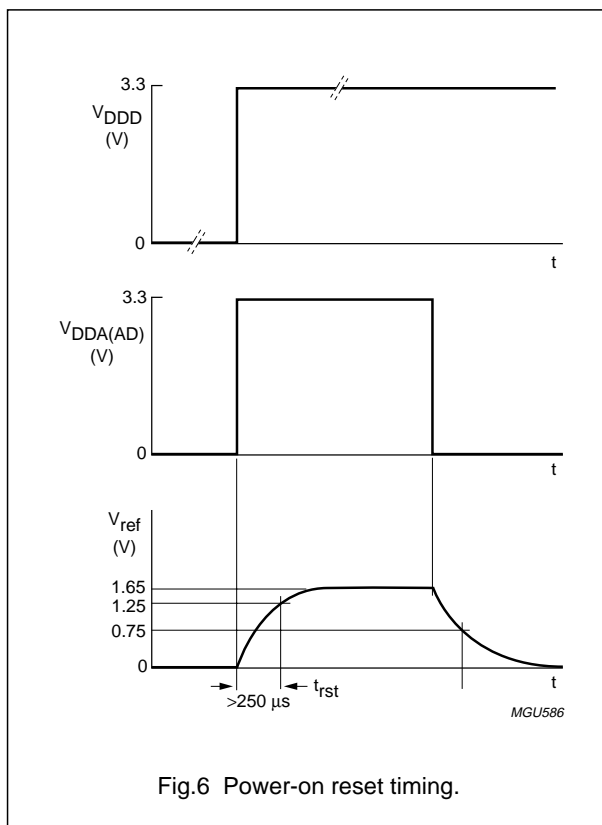

Multichannel audio coder-decoder

UDA1338H

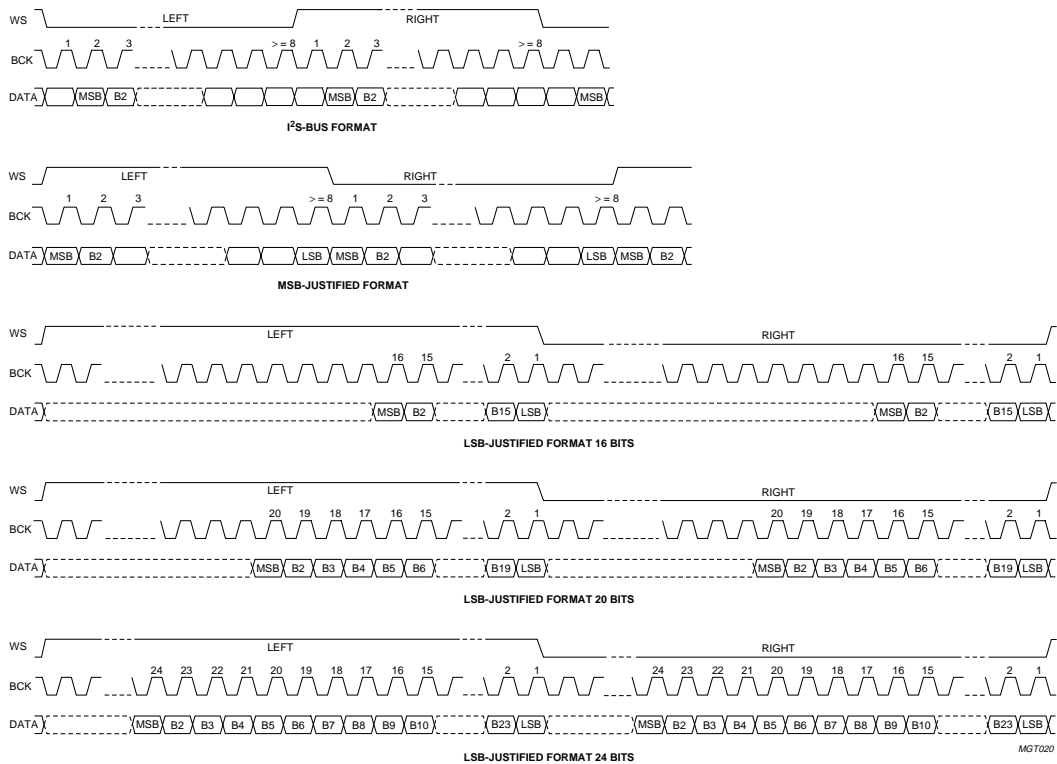
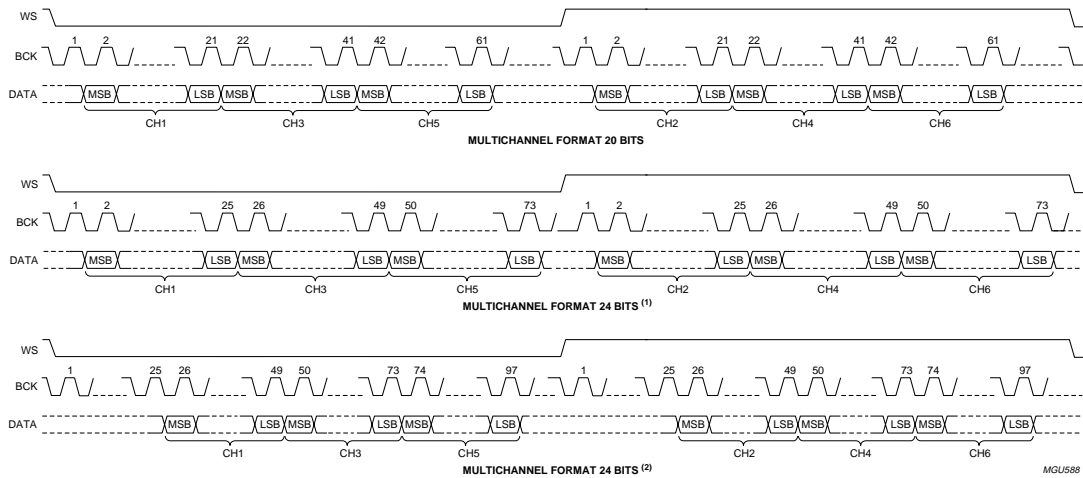

Fig.7 Formats of input and output data (single-channel).

Multichannel audio coder-decoder

UDA1338H



(1) Format 1.
(2) Format 2.

Fig.8 Formats of input and output data (multichannel).

Multichannel audio coder-decoder

UDA1338H

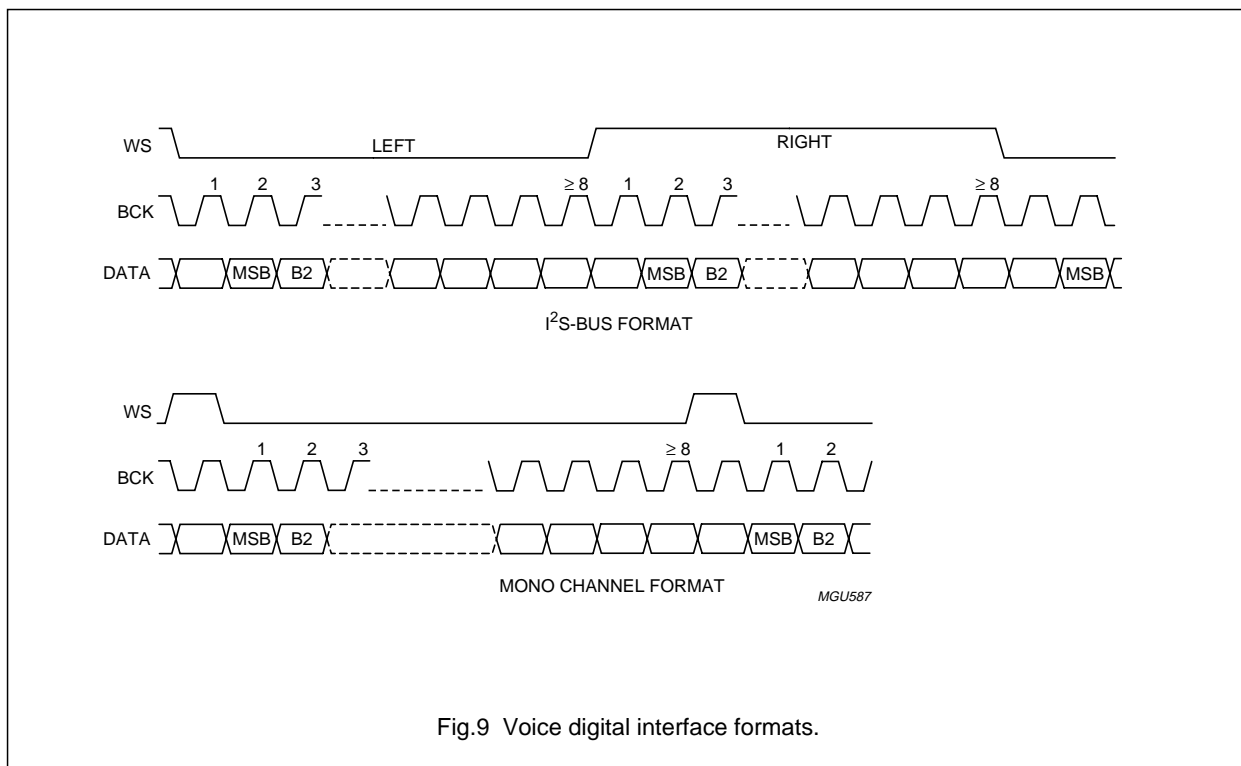

Fig.9 Voice digital interface formats.

8.13 DSD mode

The UDA1338H can receive 2.8224 MHz DSD signals and generate 88.2 kHz multibit PCM signals as well as analog signal outputs. The configuration of the UDA1338H in the DSD mode is shown in Fig.10.

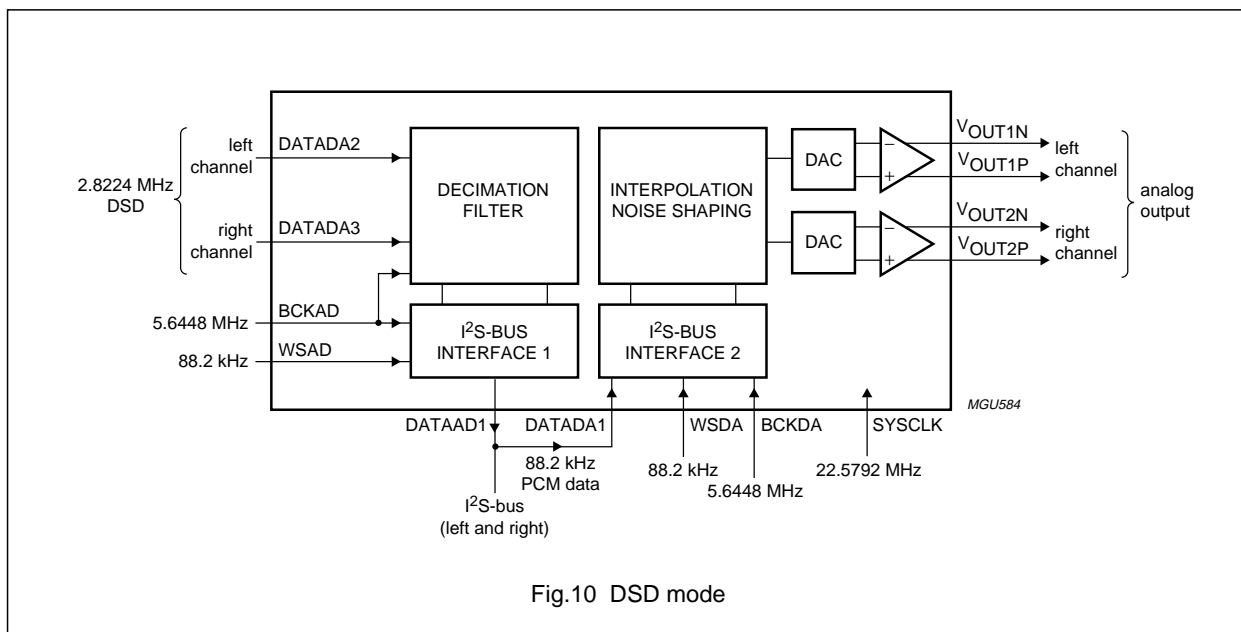

Fig.10 DSD mode

Multichannel audio coder-decoder

UDA1338H

8.14 Microcontroller interface mode

The microcontroller interface mode can be selected as shown in Table 8:

- L3-bus mode when pin I2C_L3 = LOW
- I²C-bus mode when pin I2C_L3 = HIGH.

Table 8 Pin function in the L3-bus or I²C-bus mode

PIN	LEVEL ON PIN I2C_L3	
	LOW	HIGH
	L3-BUS MODE SIGNAL	I ² C-BUS MODE SIGNAL
MCCLK	L3CLOCK	SCL
MCDATA	L3DATA	SDA
MCMODE	L3MODE	QMUTE

Table 9 QMUTE

SIGNAL QMUTE	FUNCTION
LOW	no muting
HIGH	muting

All the features are accessible with the I²C-bus interface protocol as with the L3-bus interface protocol.

The detailed description of the device operation in the L3-bus mode and I²C-bus mode is given in Chapters 9 and 10, respectively.

9 L3-BUS INTERFACE

9.1 General

The UDA1338H has an L3-bus microcontroller interface and all the digital sound processing features and various system settings can be controlled by a microcontroller.

The exchange of data and control information between the microcontroller and the UDA1338H is LSB first and is accomplished through a serial hardware L3-bus interface comprising the following pins:

- MCCLK: clock line with signal L3CLOCK
- MCDATA: data line with signal L3DATA
- MCMODE: mode line with signal L3MODE.

The L3-bus format has two modes of operation:

- Address mode
- Data transfer mode.

The address mode is used to select a device for a subsequent data transfer. The address mode is characterized by signal L3MODE = LOW and a burst of 8 pulses for signal L3CLOCK, accompanied by 8 bits (see Fig.11).

The data transfer mode is characterized by signal L3MODE = HIGH and is used to transfer one or more bytes representing a register address, instruction or data.

Basically, two types of data transfers can be defined:

- Write action: data transfer **to** the device
- Read action: data transfer **from** the device.

9.2 Device addressing

The device address consists of one byte with:

- Data Operating Mode (DOM) bits 0 and 1 representing the type of data transfer (see Table 8)
- Address bits 2 to 7 representing a 6-bit device address. The address of the UDA1338H is 01 0100 (bits 2 to 7).

Table 10 Selection of data transfer

DOM		TRANSFER
BIT 0	BIT 1	
0	0	not used
1	0	not used
0	1	write data or prepare read
1	1	read data

9.3 Register addressing

After sending the device address (including DOM bits), indicating whether the information is to be read or written, one data byte is sent using bit 0 to indicate whether the information will be read or written and bits 1 to 7 for the destination register address.

Basically, there are 3 methods for register addressing:

1. Addressing for write data: bit 0 is logic 0 indicating a write action to the destination register, followed by bits 1 to 7 indicating the register address (see Fig.11)
2. Addressing for prepare read: bit is logic 1, indicating that data will be read from the register (see Fig.12)
3. Addressing for data read action. Here, the device returns a register address prior to sending data from that register. When bit 0 is logic 0, the register address is valid; when bit 0 is logic 1, the register address is invalid (see Fig.12).

Multichannel audio coder-decoder

UDA1338H

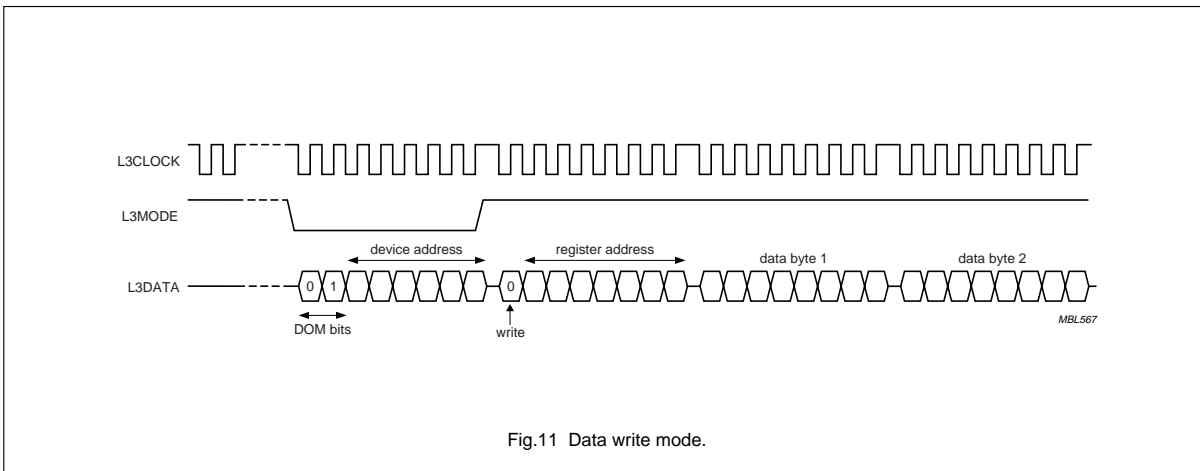

Fig.11 Data write mode.

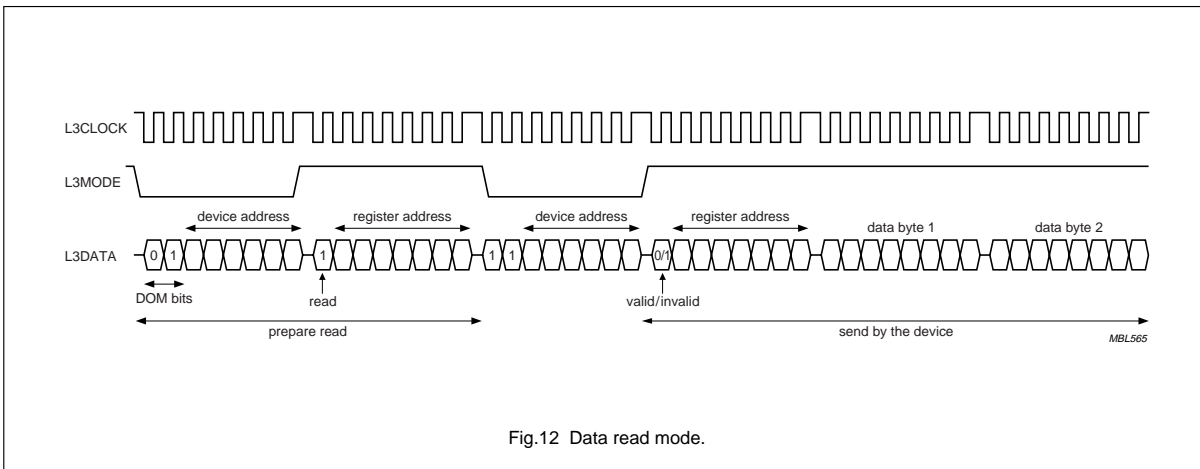

Fig.12 Data read mode.

Multichannel audio coder-decoder

UDA1338H

9.4 Data write mode

The data write mode is explained in the signal diagram of Fig.11. For writing data to a device, 4 bytes must be sent (see Table 11):

1. Byte 1 starting with '01' for signalling the write action to the device, followed by the device address '01 0100'.
2. Byte 2 starting with a '0' for signalling the write action, followed by 7 bits indicating the destination address in binary format with bit A6 being the MSB and bit A0 being the LSB.
3. Byte 3 with bit D15 being the MSB.
4. Byte 4 with bit D0 being the LSB.

It should be noted that each time a new destination register address needs to be written, the device address must be sent again.

9.5 Data read mode

To read data from the device, a prepare read must first be done and then data read. The data read mode is explained in the signal diagram of Fig.12.

For reading data from a device, the following 6 bytes are involved (see Table 12):

1. Byte 1 with the device address, including '01' for signalling the write action to the device.
2. Byte 2 is sent with the register address from which data needs to be read. This byte starts with a '1', which indicates that there will be a read action from the register, followed by 7 bits for the destination address in binary format, with bit A6 being the MSB and bit A0 being the LSB.
3. Byte 3 with the device address, including '11' is sent to the device. The '11' indicates that the device must write data to the microcontroller.
4. Byte 4 sent by the device to the bus, with the (requested) register address and a flag bit indicating whether the requested register was valid (bit is logic 0) or invalid (bit is logic 1).
5. Byte 5 sent by the device to the bus, with the data information in binary format, with bit D15 being the MSB.
6. Byte 6 sent by the device to the bus, with the data information in binary format, with bit D0 being the LSB.

Table 11 L3-bus write data

BYTE	L3-BUS MODE	ACTION	FIRST IN TIME				LATEST IN TIME			
			BIT 0	BIT 1	BIT 2	BIT 3	BIT 4	BIT 5	BIT 6	BIT 7
1	address	device address	0	1	0	1	0	1	0	0
2	data transfer	register address	0	A6	A5	A4	A3	A2	A1	A0
3	data transfer	data byte 1	D15	D14	D13	D12	D11	D10	D9	D8
4	data transfer	data byte 2	D7	D6	D5	D4	D3	D2	D1	D0

Table 12 L3-bus read data

BYTE	L3-BUS MODE	ACTION	FIRST IN TIME				LATEST IN TIME			
			BIT 0	BIT 1	BIT 2	BIT 3	BIT 4	BIT 5	BIT 6	BIT 7
1	address	device address	0	1	0	1	0	1	0	0
2	data transfer	register address	1	A6	A5	A4	A3	A2	A1	A0
3	address	device address	1	1	0	1	0	1	0	0
4	data transfer	register address	0 or 1	A6	A5	A4	A3	A2	A1	A0
5	data transfer	data byte 1	D15	D14	D13	D12	D11	D10	D9	D8
6	data transfer	data byte 2	D7	D6	D5	D4	D3	D2	D1	D0

Multichannel audio coder-decoder

UDA1338H

10 I²C-BUS INTERFACE**10.1 General**

The UDA1338H has an I²C-bus microcontroller interface. All the features are accessible with the I²C-bus interface protocol. In the I²C-bus mode, the DAC mute function is accessible via pin MCMODE with signal QMUTE.

The exchange of data and control information between the microcontroller and the UDA1338H is accomplished through a serial hardware interface comprising the following pins as shown in Table 8:

- MCCLK: clock line with signal SCL
- MCDATA: data line with signal SDA.

10.2 Characteristics of the I²C-bus

The bus is for 2-way, 2-line communication between different ICs or modules. The two lines are a serial data line (SDA) and a serial clock line (SCL). Both lines must be connected to the supply voltage V_{DD} via a pull-up resistor when connected to the output stages of a microcontroller. For a 400 kHz IC, the recommendation for this type of bus from Philips Semiconductors must be followed (e.g. up to loads of 200 pF on the bus a pull-up resistor can be used, between 200 and 400 pF a current source or switched resistor must be used). Data transfer can only be initiated when the bus is not busy.

10.3 Bit transfer

One data bit is transferred during each clock pulse (see Fig.13). The data on the SDA line must remain stable during the HIGH period of the clock pulse as changes in the data line at this time will be interpreted as control signals. The maximum clock frequency is 400 kHz.

To be able to run on this high frequency, all the inputs and outputs connected to this bus must be designed for this high-speed I²C-bus according to the Philips specification.

10.4 Byte transfer

Each byte (8 bits) is transferred with the MSB first (see Table 13).

Table 13 Byte transfer

MSB		BIT NUMBER				LSB	
7	6	5	4	3	2	1	0

10.5 Data transfer

A device generating a message is a transmitter; a device receiving a message is the receiver. The device that controls the message is the master and the devices which are controlled by the master are the slaves.

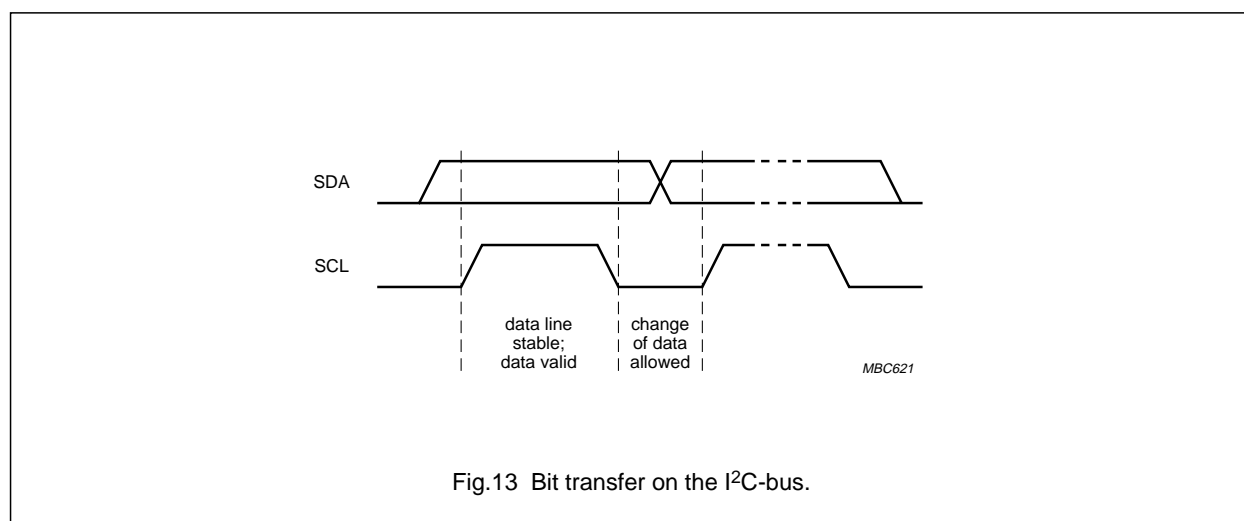
Fig.13 Bit transfer on the I²C-bus.

Multichannel audio coder-decoder

UDA1338H

10.6 Start and stop conditions

Both data and clock line will remain HIGH when the bus is not busy. A HIGH-to-LOW transition of the data line, while the clock is HIGH, is defined as a start condition (S); see Fig.14. A LOW-to-HIGH transition of the data line while the clock is HIGH is defined as a stop condition (P).

10.7 Acknowledgment

The number of data bits transferred between the start and stop conditions from the transmitter to receiver is not limited. Each byte of eight bits is followed by one acknowledge bit (see Fig.15). At the acknowledge bit the data line is released by the master and the master generates an extra acknowledge related clock pulse.

A slave receiver which is addressed, must generate an acknowledge after the reception of each byte. Also a master must generate an acknowledge after the reception of each byte that has been clocked out of the slave transmitter.

The device that acknowledges has to pull down the SDA line during the acknowledge clock pulse, so the SDA line is stable LOW during the HIGH period of the acknowledge related clock pulse. Set-up and hold times must be taken into account. A master receiver must signal an end of data to the transmitter by not generating an acknowledge on the last byte that has been clocked out of the slave. In this event, the transmitter must leave the data line HIGH to enable the master to generate a stop condition.

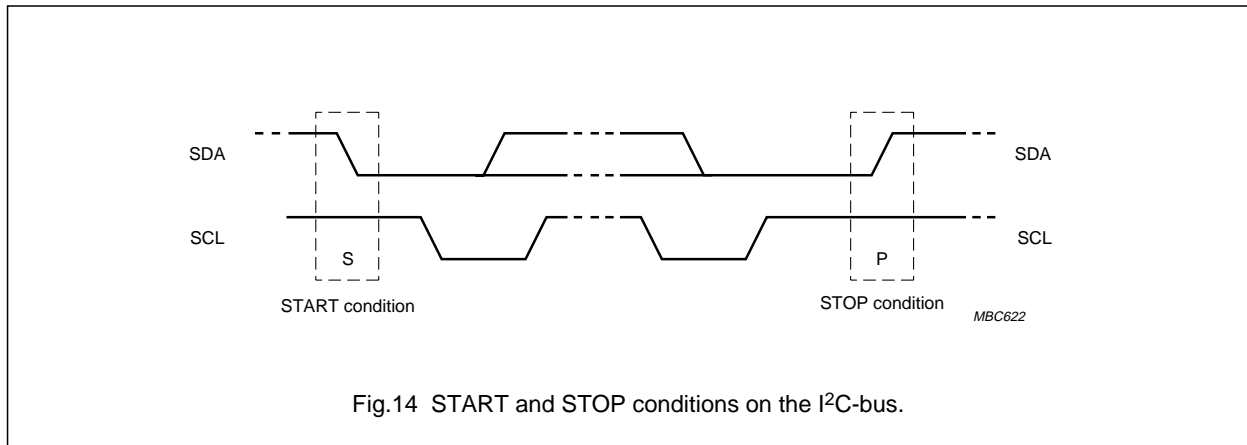

Fig.14 START and STOP conditions on the I²C-bus.

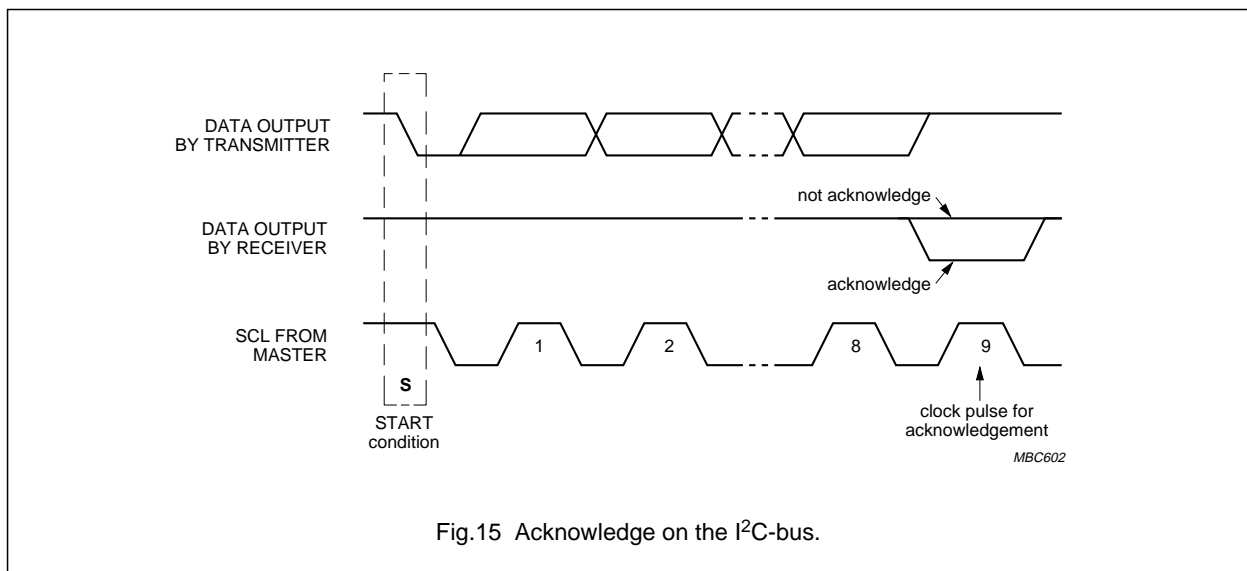

Fig.15 Acknowledge on the I²C-bus.

Multichannel audio coder-decoder
UDA1338H

10.8 Device address

Before any data is transmitted on the I²C-bus, the device which should respond is addressed first. The addressing is always done with byte 1 transmitted after the start procedure. The UDA1338H acts as a slave receiver or a slave transmitter.

Therefore, the clock signal SCL is only an input signal. The data signal SDA is a bidirectional line. The UDA1338H device address is shown in Table 14.

Table 14 I²C-bus device address of UDA1338H

DEVICE ADDRESS							R/W
A6	A5	A4	A3	A2	A1	A0	–
0	0	1	1	0	0	0	0/1

10.9 Register address

The register addresses in the I²C-bus mode are the same as in the L3-bus mode. The register addresses are defined in Chapter 11.

10.10 Write and read data

The I²C-bus configurations for a write and read cycle are shown in Tables 15 and 16, respectively.

The write cycle is used to write groups of two bytes to the internal registers for the settings. It is also possible to read the registers for the device status information.

10.11 Write cycle

The I²C-bus configuration for a write cycle is shown in Table 15. The write cycle is used to write the data to the internal registers. The device and register addresses are one byte each, the setting data is always a pair of two bytes.

The format of the write cycle is as follows:

1. The microcontroller starts with a start condition (S).
2. The first byte (8 bits) contains the device address '0011 000' and a logic 0 (write) for the R/W bit.
3. This is followed by an acknowledge (A) from the UDA1338H.
4. After this the microcontroller writes the 8-bit register address (ADDR) where the writing of the register content of the UDA1338H must start.
5. The UDA1338H acknowledges this register address (A).
6. The microcontroller sends 2 bytes data with the Most Significant (MS) byte first and then the Least Significant (LS) byte. After each byte an acknowledge is followed from the UDA1338H.
7. If repeated groups of 2 bytes data are transmitted, then the register address is auto incremented. After each byte an acknowledge is followed from the UDA1338H.
8. Finally, the UDA1338H frees the I²C-bus and the microcontroller can generate a stop condition (P).

Table 15 Master transmitter writes to UDA1338H registers in the I²C-bus mode

	DEVICE ADDRESS	R/W		REGISTER ADDRESS		DATA 1			DATA 2 ⁽¹⁾			DATA n ⁽¹⁾						
S	0011 000	0	A	ADDR	A	MS1	A	LS1	A	MS2	A	LS2	A	MSn	A	LSn	A	P
	acknowledge from UDA1338H																	

Note

1. Auto increment of register address.

10.12 Read cycle

The read cycle is used to read the data values from the internal registers. The I²C-bus configuration for a read cycle is shown in Table 16.

The format of the read cycle is as follows:

1. The microcontroller starts with a start condition (S).
2. The first byte (8 bits) contains the device address '0011 000' and a logic 0 (write) for the R/W bit.
3. This is followed by an acknowledge (A) from the UDA1338H.
4. After this the microcontroller writes the 8-bit register address (ADDR) where the reading of the register content of the UDA1338H must start.
5. The UDA1338H acknowledges this register address.
6. Then the microcontroller generates a repeated start (Sr).
7. Then the microcontroller generates the device address '0011 000' again, but this time followed by a logic 1 (read) of the R/W bit. An acknowledge is followed from the UDA1338H.
8. The UDA1338H sends 2 bytes data with the Most Significant (MS) byte first and then the Least Significant (LS) byte. After each byte an acknowledge is followed from the microcontroller (master).
9. If repeated groups of 2 bytes are transmitted, then the register address is auto incremented. After each byte an acknowledge is followed from the microcontroller.
10. The microcontroller stops this cycle by generating a negative acknowledge (NA).
11. Finally, the UDA1338H frees the I²C-bus and the microcontroller can generate a stop condition (P).

Table 16 Master transmitter reads from the UDA1338H registers in the I²C-bus mode

	DEVICE ADDRESS	R/W	REGISTER ADDRESS		DEVICE ADDRESS	R/W	DATA 1	DATA 2 ⁽¹⁾	DATA n ⁽¹⁾													
S	0011 000	0	A	ADDR	A	Sr	0011 000	1	A	MS1	A	LS1	A	MS2	A	LS2	A	MSn	A	LSn	NA	P
							acknowledge from UDA1338H															
							acknowledge from master															

Note

1. Auto increment of register address.

Multichannel audio coder-decoder

UDA1338H

11 REGISTER MAPPING

In this chapter the register addressing and mapping of the microcontroller interface of the UDA1338H is given.

In Table 17 an overview of the register mapping is given.

In Table 18 the actual register mapping is given and the register definitions are explained in Sections 11.3 to 11.14.

11.1 Address mapping

Table 17 Overview of register mapping

ADDRESS	FUNCTION
System settings	
00H	system
01H	audio ADC and DAC subsystem
02H	voice ADC system
Status (read out registers)	
0FH	status outputs
Interpolator settings	
10H	DAC channel and feature selection
11H	DAC feature control
12H	DAC channel 1
13H	DAC channel 2
14H	DAC channel 3
15H	DAC channel 4
16H	DAC channel 5
17H	DAC channel 6
18H	DAC mixing channel 1
19H	DAC mixing channel 2
1AH	DAC mixing channel 3
1BH	DAC mixing channel 4
1CH	DAC mixing channel 5
1DH	DAC mixing channel 6
ADC input amplifier gain settings	
20H	audio ADC input amplifier gain
21H	voice ADC input amplifier gain
Supplemental settings	
30H	supplemental settings 1
31H	supplemental settings 2

Multichannel audio coder-decoder

UDA1338H

11.2 Register mapping

Table 18 UDA1338H register mapping; note 1

ADD	FUNCTION	D15	D14	D13	D12	D11	D10	D9	D8	D7	D6	D5	D4	D3	D2	D1	D0	
System settings																		
00H	system	RST ⁽²⁾	VFS1	VFS0	VCE	VAP	DSD	SC1	SC0	OP1	OP0	FS1	FS0	ACE	ADP	DCE	DAP	
		–	0	0	1	0	0	0	0	0	0	0	0	1	1	0	1	0
01H	audio ADC and DAC subsystem	DC	PAB	PAA	MTB	MTA	AIF2	AIF1	AIF0	DAG	FIL	DVD	DIS1	DIS0	DIF2	DIF1	DIF0	
		1	0	0	0	0	0	0	0	0	0	0	0	0	0	0	0	
02H	voice ADC system	–	–	–	–	–	–	–	–	BCK1	BCK0	WSM	VH1	VH0	PVA	MTV	VIF	
		0	0	0	0	0	0	0	0	0	1	1	0	1	0	0	0	
Status (read out only)																		
0FH	status outputs	–	–	–	–	–	–	–	–	–	–	VS	AS1	AS0	DS2	DS1	DS0	
Interpolator settings																		
10H	DAC channel and feature selection	MIX1	MIX0	MC5	MC4	MC3	MC2	MC1	MC0	SEL1	SEL0	CS5	CS4	CS3	CS2	CS1	CS0	
		0	0	0	0	0	0	0	0	0	0	0	0	0	0	0	0	
11H	DAC feature control	ICS1	ICS0	DE2	DE1	DE0	PD	MT	QM	VC7	VC6	VC5	VC4	VC3	VC2	VC1	VC0	
		0	0	0	0	0	0	0	0	0	0	0	0	0	0	0	0	
12H	DAC channel 1	ICS1	ICS0	DE2	DE1	DE0	PD	MT	QM	VC7	VC6	VC5	VC4	VC3	VC2	VC1	VC0	
		0	0	0	0	0	0	0	0	0	0	0	0	0	0	0	0	
13H	DAC channel 2	–	–	DE2	DE1	DE0	PD	MT	QM	VC7	VC6	VC5	VC4	VC3	VC2	VC1	VC0	
		0	0	0	0	0	0	0	0	0	0	0	0	0	0	0	0	
14H	DAC channel 3	ICS1	ICS0	DE2	DE1	DE0	PD	MT	QM	VC7	VC6	VC5	VC4	VC3	VC2	VC1	VC0	
		0	0	0	0	0	0	0	0	0	0	0	0	0	0	0	0	
15H	DAC channel 4	–	–	DE2	DE1	DE0	PD	MT	QM	VC7	VC6	VC5	VC4	VC3	VC2	VC1	VC0	
		0	0	0	0	0	0	0	0	0	0	0	0	0	0	0	0	
16H	DAC channel 5	ICS1	ICS0	DE2	DE1	DE0	PD	MT	QM	VC7	VC6	VC5	VC4	VC3	VC2	VC1	VC0	
		0	0	0	0	0	0	0	0	0	0	0	0	0	0	0	0	
17H	DAC channel 6	–	–	DE2	DE1	DE0	PD	MT	QM	VC7	VC6	VC5	VC4	VC3	VC2	VC1	VC0	
		0	0	0	0	0	0	0	0	0	0	0	0	0	0	0	0	

Multichannel audio coder-decoder

UDA1338H

ADD	FUNCTION	D15	D14	D13	D12	D11	D10	D9	D8	D7	D6	D5	D4	D3	D2	D1	D0
18H	DAC mixing channel 1	ICS1	ICS0	–	–	–	PD	MT	QM	VC7	VC6	VC5	VC4	VC3	VC2	VC1	VC0
		0	0	0	0	0	0	0	0	0	0	0	0	0	0	0	0
19H	DAC mixing channel 2	–	–	–	–	–	PD	MT	QM	VC7	VC6	VC5	VC4	VC3	VC2	VC1	VC0
		0	0	0	0	0	0	0	0	0	0	0	0	0	0	0	0
1AH	DAC mixing channel 3	ICS1	ICS0	–	–	–	PD	MT	QM	VC7	VC6	VC5	VC4	VC3	VC2	VC1	VC0
		0	0	0	0	0	0	0	0	0	0	0	0	0	0	0	0
1BH	DAC mixing channel 4	–	–	–	–	–	PD	MT	QM	VC7	VC6	VC5	VC4	VC3	VC2	VC1	VC0
		0	0	0	0	0	0	0	0	0	0	0	0	0	0	0	0
1CH	DAC mixing channel 5	ICS1	ICS0	–	–	–	PD	MT	QM	VC7	VC6	VC5	VC4	VC3	VC2	VC1	VC0
		0	0	0	0	0	0	0	0	0	0	0	0	0	0	0	0
1DH	DAC mixing channel 6	–	–	–	–	–	PD	MT	QM	VC7	VC6	VC5	VC4	VC3	VC2	VC1	VC0
		0	0	0	0	0	0	0	0	0	0	0	0	0	0	0	0
ADC input amplifier gain settings																	
20H	ADC 1 and ADC 2 input amplifier gain	–	–	–	–	IB3	IB2	IB1	IB0	–	–	–	–	IA3	IA2	IA1	IA0
		0	0	0	0	0	0	0	0	0	0	0	0	0	0	0	0
21H	voice ADC input amplifier gain	–	–	–	–	–	–	–	–	–	–	–	IV4	IV3	IV2	IV1	IV0
		–	–	–	–	–	–	–	–	0	0	0	0	0	0	0	0
Supplemental settings																	
30H	supplemental settings 1	–	–	–	–	–	–	–	–	PDT	–	–	–	–	–	–	–
		0	0	0	0	0	0	0	0	0	0	0	0	0	0	0	0
31H	supplemental settings 2	–	–	–	–	–	–	–	–	–	DITH2	DITH1	DITH0	–	–	VMTP	PDLN A
		0	0	0	0	0	0	0	0	0	0	0	0	0	0	0	0

Note

- When writing new settings via the L3-bus interface, the default values should always be set to warrant correct operation. Read access to the DAC features register 11H will not return valid data.
- When bit RST is set to logic 1, the default values are set to all the registers as shown in Table 18. When start-up, all the registers in 00H are initialized as the default values and the mute control bits MTA, MTB, MTV, MT and QM are set to logic 1. All other registers have non fixed values.

Multichannel audio coder-decoder

UDA1338H

11.3 System settings

Table 19 System register (address 00H)

BIT	15	14	13	12	11	10	9	8
Symbol	RST	VFS1	VFS0	VCE	VAP	DSD	SC1	SC0
Reset default	–	0	0	1	0	0	0	0

BIT	7	6	5	4	3	2	1	0
Symbol	OP1	OP0	FS1	FS0	ACE	ADP	DCE	DAP
Reset default	0	0	0	1	1	0	1	0

Table 20 Description of system register bits

BIT	SYMBOL	DESCRIPTION
15	RST	Reset. A 1-bit value to initialize the L3-bus registers with the default settings by writing bit RST = 1. If bit RST = 0, there is no reset.
14 to 13	VFS[1:0]	Voice ADC sampling frequency. A 2-bit value to select the voice ADC sampling frequency. Default 00. See Table 21.
12	VCE	Voice ADC clock enable. A 1-bit value to enable the voice ADC clock. If bit VCE = 1 (default), then the clock is enabled; if bit VCE = 0, then the clock is disabled.
11	VAP	Voice ADC power control. A 1-bit value to reduce the power consumption of the voice ADC. If bit VAP = 1, then the state is power-on; if bit VAP = 0 (default), then the state is power-off.
10	DSD	DSD mode selection. A 1-bit value to select the DSD mode. If bit DSD = 1, then the DSD mode; if bit DSD = 0 (default), then the normal mode.
9 to 8	SC[1:0]	System clock frequency. A 2-bit value to select the used external clock frequency. $128f_s$ system clock for the DAC can be used by setting bit DVD = 1. Default 00. See Table 22.
7 to 6	OP[1:0]	Operating mode selection. A 2-bit value to select the operation mode of the audio ADC and DAC. Default 00. See Table 23.
5 to 4	FS[1:0]	Sampling frequency. A 2-bit value to select the sampling frequency of the audio ADC and DAC in the WS mode. Default 01. See Table 24.
3	ACE	ADC clock enable. A 1-bit value to enable the audio ADC clock. If bit ACE = 1 (default), then the clock is enabled; if bit ACE = 0, then the clock is disabled.
2	ADP	ADC power control. A 1-bit value to reduce the power consumption of the audio ADC. If bit ADP = 1, then the state is power-on; if bit ADP = 0 (default), then the state is power-off.
1	DCE	DAC clock enable. A 1-bit value to enable the DAC clock. If bit DCE = 1 (default), then the clock is enabled; if bit DCE = 0, then the clock is disabled.
0	DAP	DAC power control. A 1-bit value to reduce the power consumption of the DAC. If bit DAP = 1, then the state is power-on; if bit DAP = 0 (default), then the state is power-off.

Multichannel audio coder-decoder

UDA1338H

Table 21 Voice ADC sampling frequency bits

VFS1	VFS0	FUNCTION
0	0	6.25 to 12.5 kHz (default)
0	1	12.5 to 25 kHz
1	0	25 to 50 kHz
1	1	reserved

Table 22 System clock frequency bits

SC1	SC0	ADC	DAC		REMARK
			BIT DVD = 0	BIT DVD = 1	
0	0	256f _s	256f _s	128f _s	default
0	1	384f _s	384f _s	192f _s	
1	0	512f _s	512f _s	256f _s	
1	1	768f _s	768f _s	384f _s	

Table 23 Operating mode bits

OP1	OP0	ADC MODE	DAC MODE	REMARK
0	0	SYSClk (256f _s , 384f _s , 512f _s or 768f _s)	SYSClk (128f _s , 256f _s , 384f _s , 512f _s or 768f _s)	default
0	1	SYSClk (256f _s , 384f _s , 512f _s or 768f _s)	WSDA (1f _s)	
1	0	WSAD (1f _s)	SYSClk (128f _s , 256f _s , 384f _s , 512f _s or 768f _s)	
1	1	WSDA (1f _s)	WSDA (1f _s)	

Table 24 Audio ADC and DAC sampling frequency bits

FS1	FS0	FUNCTION
0	0	12.5 to 25 kHz
0	1	25 to 50 kHz (default)
1	0	50 to 100 kHz
1	1	100 to 200 kHz

11.4 Audio ADC and DAC subsystem settings**Table 25** Audio ADC and DAC subsystem register (address 01H)

BIT	15	14	13	12	11	10	9	8
Symbol	DC	PAB	PAA	MTB	MTA	AIF2	AIF1	AIF0
Reset default	1	0	0	0	0	0	0	0

BIT	7	6	5	4	3	2	1	0
Symbol	DAG	FIL	DVD	DIS1	DIS0	DIF2	DIF1	DIF0
Reset default	0	0	0	0	0	0	0	0

Multichannel audio coder-decoder

UDA1338H

Table 26 Description of the audio ADC and DAC subsystem register bits

BIT	SYMBOL	DESCRIPTION
15	DC	ADC DC-filter. A 1-bit value to enable the digital DC-filter of the ADC. If bit DC = 1 (default), then the DC-filtering is active; if bit DC = 0, then there is no DC-filtering.
14	PAB	Polarity ADC 2 control. A 1-bit value to control the ADC 2 polarity. If bit PAB = 1, then the polarity is inverted; if bit PAB = 0 (default), then the polarity is non-inverted.
13	PAA	Polarity ADC 1 control. A 1-bit value to control the ADC 1 polarity. If bit PAA = 1, then the polarity is inverted; if bit PAA = 0 (default), then the polarity is non-inverted.
12	MTB	Mute ADC 2. A 1-bit value to enable the digital mute of ADC 2. If bit MTB = 1, then ADC 2 is soft muted; if bit MTB = 0 (default), then ADC 2 is not muted.
11	MTA	Mute ADC 1. A 1-bit value to enable the digital mute of ADC 1. If bit MTA = 1, then ADC 1 is soft muted; if bit MTA = 0 (default), then ADC 1 is not muted.
10 to 8	AIF[2:0]	ADC output data interface format. A 3-bit value to select the used data format to the I ² S-bus ADC output interface. Default 000. See Table 27.
7	DAG	DAC gain switch. A 1-bit value to select the DAC gain. If bit DAG = 1, then the gain is 6 dB; if bit DAG = 0 (default), then the gain is 0 dB.
6	FIL	Filter selection. A 1-bit value to select the interpolation filter characteristics. If bit FIL = 1, then slow roll-off; if bit FIL = 0 (default), then sharp roll-off.
5	DVD	192 kHz sampling mode selection. A 1-bit value to select the oversampling rate of the noise shaper. The 64f _s rate is used for 192 and 176.4 kHz sampling frequencies. If 7bit DVD = 1, then 64f _s rate is selected (192 kHz sampling mode); if bit DVD = 0 (default), then 128f _s rate is selected.
4 to 3	DIS[1:0]	Data interface selection. A 2-bit value to select the data interface connection. Default 00. See Table 28.
2 to 0	DIF[2:0]	DAC input data interface format. A 3-bit value to select the used data format to the I ² S-bus DAC input interface. Default 000. See Table 27.

Table 27 Data interface format bits

AIF2	AIF1	AIF0	FUNCTION
DIF2	DIF1	DIF0	
0	0	0	I ² S-bus format (default)
0	0	1	LSB-justified format, 16 bits
0	1	0	LSB-justified format, 20 bits
0	1	1	LSB-justified format, 24 bits
1	0	0	MSB-justified format
1	0	1	multichannel format, 20 bits
1	1	0	multichannel format, 24 bits (format 1)
1	1	1	multichannel format, 24 bits (format 2)

Multichannel audio coder-decoder

UDA1338H

Table 28 Data interface selection bits

DIS1	DIS0	INPUT TO DAC
0	0	DATADA1 to DAC channel 1 and 2, DATADA2 to DAC channel 3 and 4, and DATADA3 to DAC channel 5 and 6 (default)
0	1	DATADA1 to DAC channels 1 to 6
1	0	DATADA2 to DAC channels 1 to 6
1	1	DATADA3 to DAC channels 1 to 6

11.5 Voice ADC system settings**Table 29** Voice ADC system register (address 02H)

BIT	15	14	13	12	11	10	9	8
Symbol	–	–	–	–	–	–	–	–
Reset default	0	0	0	0	0	0	0	0

BIT	7	6	5	4	3	2	1	0
Symbol	BCK1	BCK0	WSM	VH1	VH0	PVA	MTV	VIF
Reset default	0	1	1	0	1	0	0	0

Table 30 Description of the voice ADC system register bits

BIT	SYMBOL	DESCRIPTION
15 to 8	–	default 0000 0000
7 to 6	BCK[1:0]	BCK frequency of voice ADC. A 2-bit value to select the BCK frequency of the voice ADC in the WSV-out mode. Default 01. See Table 31.
5	WSM	WSV mode selection. A 1-bit value to select the WSV mode of the voice ADC. If bit WSM = 1 (default), then WSV-in mode; if bit WSM = 0, then WSV-out mode.
4 to 3	VH[1:0]	Voice ADC high-pass filter setting. A 2-bit value to enable the high-pass filter of the voice ADC. Default 01. See Table 32.
2	PVA	Polarity voice ADC control. A 1-bit value to control the voice ADC polarity. If bit PVA = 1, then the polarity is inverted; if bit PVA = 0 (default), then the polarity is non-inverted.
1	MTV	Mute voice ADC. A 1-bit value to enable the digital mute of the voice ADC. If bit MTV = 1, then the voice ADC is soft muted; if bit MTV = 0 (default), then the voice ADC is not muted.
0	VIF	Voice ADC interface format. A 1-bit value to select the data interface format of the voice ADC. If bit VIF = 1, then mono-channel format; if bit VIF = 0 (default), then I ² S-bus format.

Table 31 BCK frequency of voice ADC bits

BCK1	BCK0	FUNCTION
0	0	32f _s
0	1	64f _s (default)
1	0	128f _s
1	1	256f _s

Multichannel audio coder-decoder

UDA1338H

Table 32 Voice ADC high-pass filter setting bits

VH1	VH0	FUNCTION
0	0	high-pass filter off
0	1	$f_c = 0.00008f_s$ (default)
1	0	$f_c = 0.0125f_s$
1	1	$f_c = 0.025f_s$

11.6 Status output register (read only)**Table 33** Status output register (address 0FH)

BIT	15	14	13	12	11	10	9	8
Symbol	–	–	–	–	–	–	–	–

BIT	7	6	5	4	3	2	1	0
Symbol	–	–	VS	AS1	AS0	DS2	DS1	DS0

Table 34 Description of status output register bits.

BIT	SYMBOL	DESCRIPTION
15 to 6	–	not used
5	VS	Voice ADC status. A 1-bit value to indicate the hard mute status of the voice ADC. If bit VS = 1, then power-down is ready and the clock may be disabled; if bit VS = 0, then power-down is not ready and the clock should not be disabled.
4	AS1	ADC 2 status. A 1-bit value to indicate the hard mute status of ADC 2. If bit AS1 = 1, then power-down is ready and the clock may be disabled; if bit AS1 = 0, then power-down is not ready and the clock should not be disabled.
3	AS0	ADC 1 status. A 1-bit value to indicate the hard mute status of ADC 1. If bit AS0 = 1, then power-down is ready and the clock may be disabled; if bit AS0 = 0, then power-down is not ready and the clock should not be disabled.
2	DS2	DAC channel 5 and 6 status. A 1-bit value to indicate the hard mute status of DAC channel 5 and 6. If bit DS2 = 1, then power-down is ready and the clock may be disabled; if bit DS2 = 0, then power-down is not ready and the clock should not be disabled.
1	DS1	DAC channel 3 and 4 status. A 1-bit value to indicate the hard mute status of DAC channel 3 and 4. If bit DS1 = 1, then power-down is ready and the clock may be disabled; if bit DS1 = 0, then power-down is not ready and the clock should not be disabled.
0	DS0	DAC channel 1 and 2 status. A 1-bit value to indicate the hard mute status of DAC channel 1 and 2. If bit DS0 = 1, then power-down is ready and the clock may be disabled; if bit DS0 = 0, then power-down is not ready and the clock should not be disabled.

Multichannel audio coder-decoder

UDA1338H

11.7 DAC channel selection

Table 35 DAC channel select register (address 10H)

BIT	15	14	13	12	11	10	9	8
Symbol	MIX1	MIX0	MC5	MC4	MC3	MC2	MC1	MC0
Reset default	0	0	0	0	0	0	0	0

BIT	7	6	5	4	3	2	1	0
Symbol	SEL1	SEL0	CS5	CS4	CS3	CS2	CS1	CS0
Reset default	0	0	0	0	0	0	0	0

Table 36 Description of DAC channel select register bits

BIT	SYMBOL	DESCRIPTION
15 to 14	MIX[1:0]	DAC mixer setting. A 2-bit value to enable the DAC mixer. Default 00. See Table 37.
13 to 8	MC[5:0]	DAC mixing channel selection. A group of 6 enable bits to make DAC mixing channels ready for receiving feature settings through register address 11H. Only selected registers accept new settings. Default 00 0000 (no channel ready). See Table 38.
7 and 6	SEL[1:0]	Feature selection. A 2-bit value to select the features to be set through register address 11H. When the feature settings are written, only selected feature settings are changed and non selected features are kept unchanged. Default 00. See Table 39.
5 to 0	CS[5:0]	DAC channel selection. A group of 6 enable bits to make DAC channel ready for receiving feature settings through register address 11H. Default 00 0000 (no channel ready). See Table 38.

Table 37 DAC mixer setting bits

MIX1	MIX0	FUNCTION
0	0	no mixing (default)
0	1	no mixing
1	0	mixing ADC 1
1	1	mixing ADC 2

Table 38 DAC channel and mixing channel selection bits

MC5	MC4	MC3	MC2	MC1	MC0	FUNCTION
CS5	CS4	CS3	CS2	CS1	CS0	
0	0	0	0	0	1	channel 1 selected
:	:	:	:	:	:	
0	0	1	0	1	0	channel 2 and channel 4 selected
:	:	:	:	:	:	
1	1	1	1	1	1	all channels selected

Multichannel audio coder-decoder

UDA1338H

Table 39 Feature selection bits

SEL1	SEL0	FUNCTION
0	0	all features (default)
0	1	volume
1	0	mute and quick mute
1	1	de-emphasis, polarity and input channel selection

11.8 DAC features settings**Table 40** DAC features register (addresses 11H)

BIT	15	14	13	12	11	10	9	8
Symbol	ICS1	ICS0	DE2	DE1	DE0	PD	MT	QM
Reset default	0	0	0	0	0	0	0	0

BIT	7	6	5	4	3	2	1	0
Symbol	VC7	VC6	VC5	VC4	VC3	VC2	VC1	VC0
Reset default	0	0	0	0	0	0	0	0

Table 41 Description of DAC features register bits

BIT	SYMBOL	DESCRIPTION
15 to 14	ICS[1:0]	Input channel selection. A 2-bit value to select the input channels. As the controlled channels are paired off, this 2-bit value must be written to each odd channel register. Default 00. See Table 42.
13 to 11	DE[2:0]	De-emphasis setting. A 3-bit value to enable the digital de-emphasis filter. Default 000. See Table 43.
10	PD	Polarity DAC control. A 1-bit value to control the DAC polarity. If bit PD = 1, then the polarity is inverted; if bit PD = 0 (default), then the polarity is non-inverted.
9	MT	Muting. A 1-bit value to enable the digital mute. All the DAC outputs are muted at start-up. It is necessary to explicitly switch off for the audio output by means of bit MT. If bit MT = 1 (start-up), then muting; if bit MT = 0 (default), then no muting.
8	QM	Quick mute. A 1-bit value to set the quick mute mode. If bit QM = 1 (start-up), then quick mute mode; if bit QM = 0 (default), then soft mute mode.
7 to 0	VC[7:0]	Interpolator volume control. An 8-bit value to program the volume attenuation of each channel. The range is from 0 to -53 dB in steps of 0.25 dB, from -53 to -80 dB in steps of 3 dB and -∞ dB. Default 0000 0000. See Table 44.

Table 42 Input channel selection bits

ICS1	ICS0	INPUT TO DAC OUTPUT
0	0	left channel input data to odd channel output; right channel input data to even channel output
0	1	left channel input data to odd and even channel outputs
1	0	right channel input data to odd and even channel outputs
1	1	left channel input data to even channel output; right channel input data to odd channel output

Multichannel audio coder-decoder

UDA1338H

Table 43 De-emphasis bits

DE2	DE1	DE0	FUNCTION
0	0	0	no de-emphasis (default)
0	0	1	de-emphasis of 32 kHz
0	1	0	de-emphasis of 44.1 kHz
0	1	1	de-emphasis of 48 kHz
1	0	0	de-emphasis of 96 kHz
1	0	1	not used
1	1	0	not used
1	1	1	not used

Table 44 Interpolator volume control bits

VC7	VC6	VC5	VC4	VC3	VC2	VC1	VC0	VOLUME (dB)
0	0	0	0	0	0	0	0	0 (default)
0	0	0	0	0	0	0	1	-0.25
0	0	0	0	0	0	1	0	-0.50
0	0	0	0	0	0	1	1	-0.75
0	0	0	0	0	1	0	0	-1.00
0	0	0	0	0	1	0	1	-1.25
:	:	:	:	:	:	:	:	:
1	1	0	1	0	1	0	0	-53
1	1	0	1	1	0	0	0	-56
1	1	0	1	1	1	0	0	-59
1	1	1	0	0	0	0	0	-62
1	1	1	0	0	1	0	0	-65
1	1	1	0	1	0	0	0	-68
1	1	1	0	1	1	0	0	-71
1	1	1	1	0	0	0	0	-74
1	1	1	1	0	1	0	0	-77
1	1	1	1	1	0	0	0	-80
1	1	1	1	1	1	0	0	-∞
:	:	:	:	:	:	:	:	:
1	1	1	1	1	1	1	1	-∞

Multichannel audio coder-decoder

UDA1338H

11.9 DAC channel 1 to 6 settings

All the DAC features which are written in register 11H are copied into the odd channel registers.

Table 45 DAC channel 1, 3 and 5 registers (addresses 12H, 14H and 16H)

BIT	15	14	13	12	11	10	9	8
Symbol	ICS1	ICS0	DE2	DE1	DE0	PD	MT	QM
Reset default	0	0	0	0	0	0	0	0

BIT	7	6	5	4	3	2	1	0
Symbol	VC7	VC6	VC5	VC4	VC3	VC2	VC1	VC0
Reset default	0	0	0	0	0	0	0	0

All the DAC features which are written in register 11H are copied into the even channel registers, except the bits ICS[1:0].

Table 46 DAC channel 2, 4 and 6 registers (addresses 13H, 15H and 17H)

BIT	15	14	13	12	11	10	9	8
Symbol	–	–	DE2	DE1	DE0	PD	MT	QM
Reset default	0	0	0	0	0	0	0	0

BIT	7	6	5	4	3	2	1	0
Symbol	VC7	VC6	VC5	VC4	VC3	VC2	VC1	VC0
Reset default	0	0	0	0	0	0	0	0

11.10 DAC mixing channel settings

All the DAC features which are written in register 11H are copied into the odd mixing channel registers, except the bits DE[2:0].

Table 47 DAC mixing channel 1, 3 and 5 registers (addresses 18H, 1AH and 1CH)

BIT	15	14	13	12	11	10	9	8
Symbol	ICS1	ICS0	–	–	–	PD	MT	QM
Reset default	0	0	0	0	0	0	0	0

BIT	7	6	5	4	3	2	1	0
Symbol	VC7	VC6	VC5	VC4	VC3	VC2	VC1	VC0
Reset default	0	0	0	0	0	0	0	0

All the DAC features which are written in register 11H are copied into the even channel registers, except the bits ICS[1:0] and DE[2:0].

Multichannel audio coder-decoder

UDA1338H

Table 48 DAC mixing channel 2, 4 and 6 registers (addresses 19H, 1BH and 1DH)

BIT	15	14	13	12	11	10	9	8
Symbol	–	–	–	–	–	PD	MT	QM
Reset default	0	0	0	0	0	0	0	0

BIT	7	6	5	4	3	2	1	0
Symbol	VC7	VC6	VC5	VC4	VC3	VC2	VC1	VC0
Reset default	0	0	0	0	0	0	0	0

11.11 Audio ADC 1 and ADC 2 input amplifier gain settings**Table 49** Audio ADC input amplifier gain register (address 20H)

BIT	15	14	13	12	11	10	9	8
Symbol	–	–	–	–	IB3	IB2	IB1	IB0
Reset default	0	0	0	0	0	0	0	0

BIT	7	6	5	4	3	2	1	0
Symbol	–	–	–	–	IA3	IA2	IA1	IA0
Reset default	0	0	0	0	0	0	0	0

Table 50 Description of audio ADC input amplifier gain register bits

BIT	SYMBOL	DESCRIPTION
15 to 12	–	default 0000
11 to 8	IB[3:0]	Audio ADC 2 input amplifier gain. A 4-bit value to program the input amplifier gain in steps of 3 dB (9 settings). Default 0000. See Table 51.
7 to 4	–	default 0000
3 to 0	IA[3:0]	Audio ADC 1 input amplifier gain. A 4-bit value to program the input amplifier gain in steps of 3 dB (9 settings). Default 0000. See Table 51.

Table 51 Audio ADC input amplifier gain bits

IA3	IA2	IA1	IA0	GAIN (dB)
IB3	IB2	IB1	IB0	
0	0	0	0	0 (default)
0	0	0	1	+3
0	0	1	0	+6
0	0	1	1	+9
0	1	0	0	+12
0	1	0	1	+15
0	1	1	0	+18
0	1	1	1	+21
1	0	0	0	+24

Multichannel audio coder-decoder

UDA1338H

11.12 Voice ADC gain settings

Table 52 Voice ADC input amplifier gain register (address 21H)

BIT	15	14	13	12	11	10	9	8
Symbol	–	–	–	–	–	–	–	–
Reset default	–	–	–	–	–	–	–	–

BIT	7	6	5	4	3	2	1	0
Symbol	–	–	–	IV4	IV3	IV2	IV1	IV0
Reset default	0	0	0	0	0	0	0	0

Table 53 Description of voice ADC input amplifier gain register bits

BIT	SYMBOL	DESCRIPTION
15 to 8	–	not used
7 to 5	–	default 000
4 to 0	IV[4:0]	Voice ADC input amplifier gain. A 5-bit value to program the voice amplifier gain in steps of 1.5 dB (21 settings). Default 0 0000. See Table 54.

Table 54 Voice ADC input amplifier gain bits

IV4	IV3	IV2	IV1	IV0	GAIN (dB)
0	0	0	0	0	0 (default)
0	0	0	0	1	+1.5
0	0	0	1	0	+3
0	0	0	1	1	+4.5
0	0	1	0	0	+6
0	0	1	0	1	+7.5
:	:	:	:	:	:
1	0	0	1	1	+28.5
1	0	1	0	0	+30
:	:	:	:	:	not used
1	1	1	1	1	not used

11.13 Supplemental settings 1

Table 55 Supplemental settings 1 register (address 30H)

BIT	15	14	13	12	11	10	9	8
Symbol	–	–	–	–	–	–	–	–
Reset default	0	0	0	0	0	0	0	0

BIT	7	6	5	4	3	2	1	0
Symbol	PDT	–	–	–	–	–	–	–
Reset default	0	0	0	0	0	0	0	0

Multichannel audio coder-decoder

UDA1338H

Table 56 Description of supplemental settings 1 register bits

BIT	SYMBOL	DESCRIPTION
15 to 8	–	default 0000 0000
7	PDT	Power down time. A 1-bit value to select the time of the SDAC power-down sequence. If bit PDT = 1, then $1024/f_s$ seconds; if bit PDT = 0 (default), then $512/f_s$ seconds.
6 to 0	–	default 000 0000

11.14 Supplemental settings 2**Table 57** Supplemental settings 2 register (address 31H)

BIT	15	14	13	12	11	10	9	8
Symbol	–	–	–	–	–	–	–	–
Reset default	0	0	0	0	0	0	0	0

BIT	7	6	5	4	3	2	1	0
Symbol	–	DITH2	DITH1	DITH0	–	–	VMTP	PDLNA
Reset default	0	0	0	0	0	0	0	0

Table 58 Description of supplemental settings 2 register bits

BIT	SYMBOL	DESCRIPTION
15 to 7	–	default 0000 0000 0
6 to 4	DITH[2:0]	DAC dither control. A 3-bit value to control the dithering of the SDAC. Default 000. See Table 59.
3 to 2	–	default 00
1	VMTP	Voice mute period control. A 1-bit value to select the voice ADC mute period at power-up. If bit VMTP = 1, then mute for 1024 samples ($1024/f_s$); if bit VMTP = 0 (default), then mute for 2048 samples ($2048/f_s$).
0	PDLNA	Power-down voice LNA. A 1-bit value to power-down the voice ADC LNA. It should be noted that disabling the LNA requires a recovery time defined by the external RC circuit. If bit PDNLA = 1, then power-down; if bit PDNLA = 0 (default), then power-on.

Table 59 DAC dither control bits

DITH2	DITH1	DITH0	FUNCTION
0	0	0	DC dither (mid level); default
0	0	1	reserved
0	1	0	reserved
0	1	1	reserved
1	0	0	DC dither (low level)
1	0	1	DC plus AC dither (low level)
1	1	0	DC dither (high level)
1	1	1	DC plus AC dither (high level)

Multichannel audio coder-decoder

UDA1338H

12 LIMITING VALUES

In accordance with the Absolute Maximum Rating System (IEC 60134).

SYMBOL	PARAMETER	CONDITIONS	MIN.	MAX.	UNIT
V _{DD}	supply voltage	note 1	–	4.0	V
T _{xal(max)}	maximum crystal temperature		–	150	°C
T _{stg}	storage temperature		–65	+125	°C
T _{amb}	operating ambient temperature		–20	+85	°C
V _{esd}	electrostatic discharge voltage	note 2	–2000	+2000	V
		note 3	–200	+200	V

Notes

1. All supply connections must be made to the same power supply.
2. Equivalent to discharging a 100 pF capacitor via a 1.5 kΩ series resistor.
3. Equivalent to discharging a 200 pF capacitor via a 0.75 μH series inductor.

13 HANDLING

Inputs and outputs are protected against electrostatic discharge in normal handling. However, to be totally safe, it is desirable to take normal precautions appropriate to handling MOS devices.

14 QUALITY SPECIFICATION

In accordance with the “General specification for integrated circuits (SNW-FQ-611D)”.

15 THERMAL CHARACTERISTICS

SYMBOL	PARAMETER	CONDITIONS	VALUE	UNIT
R _{th(j-a)}	thermal resistance from junction to ambient	in free air	85	K/W

Multichannel audio coder-decoder

UDA1338H

16 DC CHARACTERISTICS

$V_{DDD} = V_{DDA(AD)} = V_{DDA(DA)} = 3.3\text{ V}$; $T_{\text{amb}} = 25\text{ °C}$; $R_L = 22\text{ k}\Omega$; all voltages referenced to ground (pins V_{SS}); unless otherwise specified.

SYMBOL	PARAMETER	CONDITIONS	MIN.	TYP.	MAX.	UNIT
Supplies						
$V_{DDA(AD)}$	ADC analog supply voltage	note 1	2.7	3.3	3.6	V
$V_{DDA(DA)}$	DAC analog supply voltage	note 1	2.7	3.3	3.6	V
V_{DDD}	digital supply voltage	note 1	2.7	3.3	3.6	V
$I_{DDA(AD)}$	ADC analog supply current	$f_{\text{ADC}} = 48\text{ kHz}$	–	30	–	mA
		$f_{\text{ADC}} = 96\text{ kHz}$	–	31	–	mA
$I_{DDA(DA)}$	DAC analog supply current	$f_{\text{DAC}} = 48\text{ kHz}$	–	20	–	mA
		$f_{\text{DAC}} = 96\text{ kHz}$	–	32	–	mA
I_{DDD}	digital supply current	$f_{\text{ADC}} = f_{\text{DAC}} = 48\text{ kHz}$; $f_{\text{VOICE}} = 48\text{ kHz}$	–	31	–	mA
		$f_{\text{ADC}} = f_{\text{DAC}} = 96\text{ kHz}$; $f_{\text{VOICE}} = 48\text{ kHz}$	–	55	–	mA
$I_{DDD(\text{pd})}$	digital supply current in Power down-mode	audio and voice ADCs power-down	–	tbf	–	mA
		DAC power-down	–	tbf	–	mA
Digital input pins (5 V tolerant TTL compatible)						
V_{IH}	HIGH-level input voltage		2.0	–	–	V
V_{IL}	LOW-level input voltage		–	–	0.8	V
$ I_{\text{LI}} $	input leakage current		–	–	1	μA
C_i	input capacitance		–	–	10	pF
Digital output pins						
V_{OH}	HIGH-level output voltage	$I_{\text{OH}} = -2\text{ mA}$	$0.85V_{\text{DDD}}$	–	–	V
V_{OL}	LOW-level output voltage	$I_{\text{OL}} = 2\text{ mA}$	–	–	0.4	V
Analog-to-digital converter						
V_{ref}	reference voltage on pin V_{ref}	with respect to $V_{\text{SSA(AD)}}$	$0.45V_{\text{DDA(AD)}}$	$0.5V_{\text{DDA(AD)}}$	$0.55V_{\text{DDA(AD)}}$	V
V_{ADCP}	positive reference voltage of ADC		–	$V_{\text{DDA(AD)}}$	–	V
V_{ADCN}	negative reference voltage of ADC		0.0	0.0	0.0	V
R_o	output resistance on pin V_{ref}		–	5	–	$\text{k}\Omega$
$R_{\text{i(ADC)}}$	input resistance of audio ADC		–	10	–	$\text{k}\Omega$
$R_{\text{i(VADC)}}$	input resistance of voice ADC		–	5	–	$\text{k}\Omega$
Digital-to-analog converter						
R_L	load resistance		4	–	–	$\text{k}\Omega$
R_o	output resistance		–	1	–	$\text{k}\Omega$

Note

1. All supply connections must be made to the same power supply unit.

Multichannel audio coder-decoder

UDA1338H

17 AC CHARACTERISTICS

$V_{DD} = V_{DDA(AD)} = V_{DDA(DA)} = 3.3\text{ V}$; $f_i = 1\text{ kHz}$; $T_{amb} = 25\text{ °C}$; $R_L = 22\text{ k}\Omega$; sampling frequency $f_s = 48\text{ kHz}$; all voltages referenced to ground (pins V_{SS}); unless otherwise specified.

SYMBOL	PARAMETER	CONDITIONS	MIN.	TYP.	MAX.	UNIT
Audio analog-to-digital converter						
D_0	digital output level	at 0 dB setting; 900 mV input; notes 1 and 2	-2.5	-1.2	-0.7	dB
		at 3 dB setting; 637 mV input; note 2	-	-1.2	-	dB
		at 6 dB setting; 451 mV input; note 2	-	-1.2	-	dB
		at 9 dB setting; 319 mV input; note 2	-	-1.2	-	dB
		at 12 dB setting; 226 mV input; note 2	-	-1.2	-	dB
		at 15 dB setting; 160 mV input; note 2	-	-1.2	-	dB
		at 18 dB setting; 113 mV input; note 2	-	-1.2	-	dB
		at 21 dB setting; 80 mV input; note 2	-	-1.2	-	dB
		at 24 dB setting; 57 mV input; note 2	-	-1.2	-	dB
ΔV_i	input voltage unbalance between channels		-	0.1	-	dB

Multichannel audio coder-decoder

UDA1338H

SYMBOL	PARAMETER	CONDITIONS	MIN.	TYP.	MAX.	UNIT	
(THD + N)/S	total harmonic distortion-plus-noise to signal ratio	normal mode; at -1 dBFS					
		at 0 dB setting	-	-90	-83	dB	
		at 3 dB setting	-	-90	-	dB	
		at 6 dB setting	-	-90	-	dB	
		at 9 dB setting	-	-90	-	dB	
		at 12 dB setting	-	-90	-	dB	
		at 15 dB setting	-	-89	-	dB	
		at 18 dB setting	-	-87	-	dB	
		at 21 dB setting	-	-85	-	dB	
		at 24 dB setting	-	-83	-	dB	
		normal mode; at -20 dBFS					
		at 0 dB setting	-	-75	-	dB	
		at 3 dB setting	-	tbf	-	dB	
		at 6 dB setting	-	tbf	-	dB	
		at 9 dB setting	-	tbf	-	dB	
		at 12 dB setting	-	tbf	-	dB	
		at 15 dB setting	-	tbf	-	dB	
		at 18 dB setting	-	tbf	-	dB	
		at 21 dB setting	-	tbf	-	dB	
		at 24 dB setting	-	tbf	-	dB	
		normal mode; at -60 dBFS; A-weighted					
		at 0 dB setting	-	-40	-34	dB	
		at 3 dB setting	-	-40	-	dB	
		at 6 dB setting	-	-40	-	dB	
		at 9 dB setting	-	-39	-	dB	
		at 12 dB setting	-	-38	-	dB	
		at 15 dB setting	-	-37	-	dB	
at 18 dB setting	-	-35	-	dB			
at 21 dB setting	-	-32	-	dB			
at 24 dB setting	-	-30	-	dB			
S/N	signal-to-noise ratio	code = 0; A-weighted	94	100	-	dB	
α_{cs}	channel separation		-	100	-	dB	
PSRR	power supply rejection ratio	$f_{ripple} = 1$ kHz; $V_{ripple} = 30$ mV (p-p)	-	tbf	-	dB	

Multichannel audio coder-decoder

UDA1338H

SYMBOL	PARAMETER	CONDITIONS	MIN.	TYP.	MAX.	UNIT
Voice analog-to-digital converter						
$V_{i(rms)}$	input voltage (RMS value)	at 0 dBFS digital output; 2.2 k Ω source impedance	–	50.0	–	mV
(THD + N)/S	total harmonic distortion-plus-noise to signal ratio	at –1 dBFS	–	–78	–	dB
		at –20 dBFS	–	–65	–	dB
		at –40 dBFS; A-weighted	–	–47	–	dB
S/N	signal-to-noise ratio	code = 0; A-weighted	–	87	–	dB
PSRR	power supply rejection ratio	$f_{ripple} = 1$ kHz; $V_{ripple} = 30$ mV (p-p)	–	tbf	–	dB
Digital-to-analog converter						
DIFFERENTIAL MODE						
$V_{o(rms)}$	output voltage (RMS value)	at 0 dBFS digital input	1.9	2.0	2.1	V
ΔV_o	output voltage unbalance between channels		–	<0.1	–	dB
(THD + N)/S	total harmonic distortion-plus-noise to signal ratio	at 0 dBFS	–	–100	–93	dB
		at –20 dBFS	–	–90	–	dB
		at –60 dBFS; A-weighted	–	–50	–45	dB
S/N	signal-to-noise ratio	code = 0; A-weighted	107	114	–	dB
α_{cs}	channel separation		–	117	–	dB
PSRR	power supply rejection ratio	$f_{ripple} = 1$ kHz; $V_{ripple} = 30$ mV (p-p)	–	tbf	–	dB
SINGLE-ENDED MODE						
$V_{o(rms)}$	output voltage (RMS value)	at 0 dBFS digital input	–	1.0	–	V
ΔV_o	output voltage unbalance between channels		–	<0.1	–	dB
(THD + N)/S	total harmonic distortion-plus-noise to signal ratio	at 0 dBFS	–	–90	–	dB
		at –20 dBFS	–	–85	–	dB
		at –60 dBFS; A-weighted	–	–45	–	dB
S/N	signal-to-noise ratio	code = 0; A-weighted	–	110	–	dB
α_{cs}	channel separation		–	114	–	dB
PSRR	power supply rejection ratio	$f_{ripple} = 1$ kHz; $V_{ripple} = 30$ mV (p-p)	–	tbf	–	dB

Notes

1. The input voltage can be up to 2 V (RMS) when the current through the ADC input pin is limited to approximately 1 mA by using a series resistor.
2. The input voltage to the ADC scales proportionally with the power supply voltage.

Multichannel audio coder-decoder

UDA1338H

18 TIMING

$V_{DDD} = V_{DDA(AD)} = V_{DDA(AD)} = 2.7$ to 3.6 V; $T_{amb} = -20$ to $+85$ °C; typical timing specified at sampling frequency $f_s = 48$ kHz; unless otherwise specified.

SYMBOL	PARAMETER	CONDITIONS	MIN.	TYP.	MAX.	UNIT
System clock (see Fig.16)						
T_{sys}	system clock cycle time	note 1				
		$f_{sys} = 256f_s$	35	81	780	ns
		$f_{sys} = 384f_s$	23	54	520	ns
		$f_{sys} = 512f_s$	17	41	390	ns
t_{CWL}	system clock LOW time	$f_{sys} < 19.2$ MHz	$0.3T_{sys}$	–	$0.7T_{sys}$	ns
		$f_{sys} \geq 19.2$ MHz	$0.4T_{sys}$	–	$0.6T_{sys}$	ns
t_{CWH}	system clock HIGH time	$f_{sys} < 19.2$ MHz	$0.3T_{sys}$	–	$0.7T_{sys}$	ns
		$f_{sys} \geq 19.2$ MHz	$0.4T_{sys}$	–	$0.6T_{sys}$	ns
I²S-bus interface						
SERIAL DATA OF AUDIO ADC AND DAC (see Fig.17)						
f_{BCK}	audio bit clock frequency	note 2	–	–	12.8	MHz
$T_{cy(BCK)}$	BCK cycle time		–	–	78	ns
t_{BCKH}	bit clock HIGH time		30	–	–	ns
t_{BCKL}	bit clock LOW time		30	–	–	ns
t_r	rise time		–	–	20	ns
t_f	fall time		–	–	20	ns
$t_{su(WS)}$	word select set-up time		10	–	–	ns
$t_h(WS)$	word select hold time		10	–	–	ns
$t_{su(DATAI)}$	data input set-up time		10	–	–	ns
$t_h(DATAI)$	data input hold time		10	–	–	ns
$t_h(DATAO)$	data output hold time		0	–	–	ns
$t_d(DATAO-BCK)$	data output to bit clock delay		–	–	30	ns
$t_d(DATAO-WS)$	data output to word select delay		–	–	30	ns
SERIAL DATA OF VOICE ADC						
f_{BCKV}	voice bit clock frequency	note 2	–	–	6.4	MHz
$T_{cy(BCKV)}$	BCKV cycle time		–	–	156	ns
t_{BCKVH}	bit clock HIGH time		50	–	–	ns
t_{BCKVL}	bit clock LOW time		50	–	–	ns
t_r	rise time		–	–	20	ns
t_f	fall time		–	–	20	ns
$t_{su(WSV)}$	word select set-up time		10	–	–	ns
$t_h(WSV)$	word select hold time		10	–	–	ns
$t_h(DATAV)$	data output hold time		0	–	–	ns
$t_d(DATAV-BCKV)$	data output to bit clock delay		–	–	30	ns
$t_d(DATAV-WSV)$	data output to word select delay		–	–	30	ns

Multichannel audio coder-decoder

UDA1338H

SYMBOL	PARAMETER	CONDITIONS	MIN.	TYP.	MAX.	UNIT
$t_{d(WSV-BCKV)}$	word select to bit clock delay	WSV-out mode	-30	-	+30	ns
L3-bus interface (see Figs 18 and 19)						
L3CLOCK TIMING						
$f_{cy(CLK)L3}$	L3CLK frequency		-	-	2000	kHz
$T_{cy(CLK)L3}$	L3CLOCK cycle time		500	-	-	ns
$t_{CLK(L3)H}$	L3CLOCK HIGH time		250	-	-	ns
$t_{CLK(L3)L}$	L3CLOCK LOW time		250	-	-	ns
L3MODE TIMING						
$t_{su(L3)A}$	L3MODE set-up time in address mode		190	-	-	ns
$t_{h(L3)A}$	L3MODE hold time in address mode		190	-	-	ns
$t_{su(L3)D}$	L3MODE set-up time in data transfer mode		190	-	-	ns
$t_{h(L3)D}$	L3MODE hold time in data transfer mode		190	-	-	ns
$t_{stp(L3)}$	L3MODE stop time in data transfer mode		190	-	-	ns
L3DATA TIMING						
$t_{su(L3)DA}$	L3DATA set-up time in data transfer and address mode		190	-	-	ns
$t_{h(L3)DA}$	L3DATA hold time in data transfer and address mode		30	-	-	ns
$t_{d(L3)R}$	L3DATA delay time for read data		0	-	50	ns
$t_{dis(L3)R}$	L3DATA disable time for read data		0	-	50	ns
I²C-bus interface timing (see Fig.20)						
SCL TIMING						
f_{SCL}	SCL clock frequency		0	-	400	kHz
t_{LOW}	SCL LOW time		1.3	-	-	μ s
t_{HIGH}	SCL HIGH time		0.6	-	-	μ s
t_r	rise time SDA and SCL	note 3	$20 + 0.1C_b$	-	300	ns
t_f	fall time SDA and SCL	note 3	$20 + 0.1C_b$	-	300	ns
SDA TIMING						
t_{BUF}	bus free time between STOP and START condition		1.3	-	-	μ s
$t_{SU,STA}$	set-up time repeated START		0.6	-	-	μ s
$t_{HD,STA}$	hold time START condition		0.6	-	-	μ s
$t_{SU,DAT}$	data set-up time		100	-	-	ns
$t_{HD,DAT}$	data hold time		0	-	-	μ s
$t_{SU,STO}$	set-up time STOP condition		0.6	-	-	μ s
t_{SP}	pulse width of spikes	note 4	0	-	50	ns
C_b	capacitive load for each bus line		-	-	400	pF

Multichannel audio coder-decoder

UDA1338H

Notes

1. The system clock should not exceed 58 MHz in any mode.
2. The bit clock frequency should not exceed 256 times the corresponding sampling frequency.
3. C_b is the total capacitance for each bus line.
4. To be suppressed by the input filter.

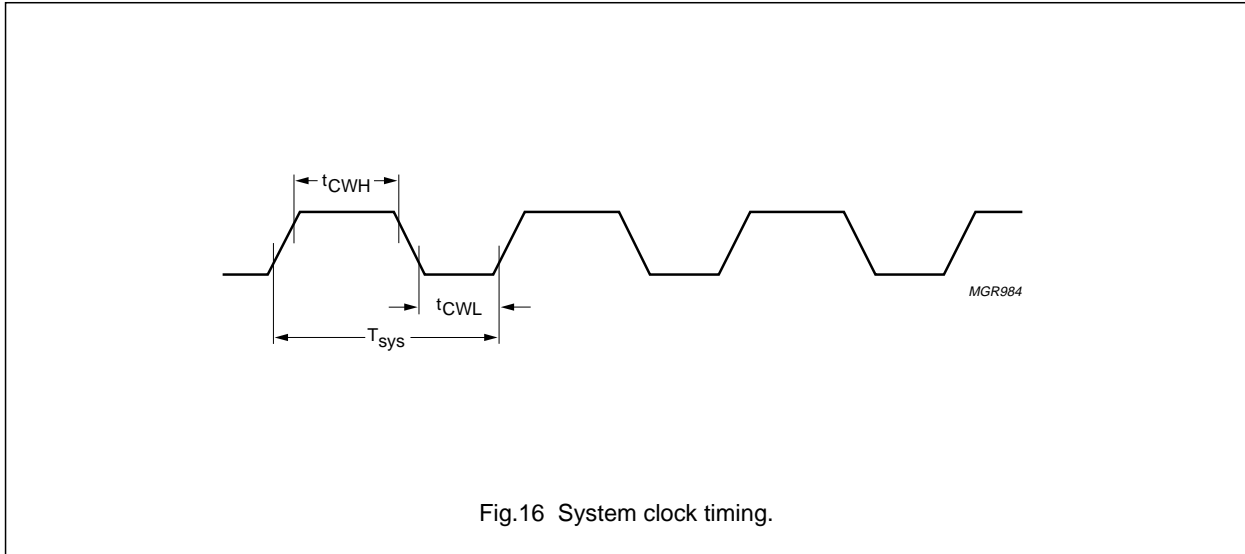

Fig.16 System clock timing.

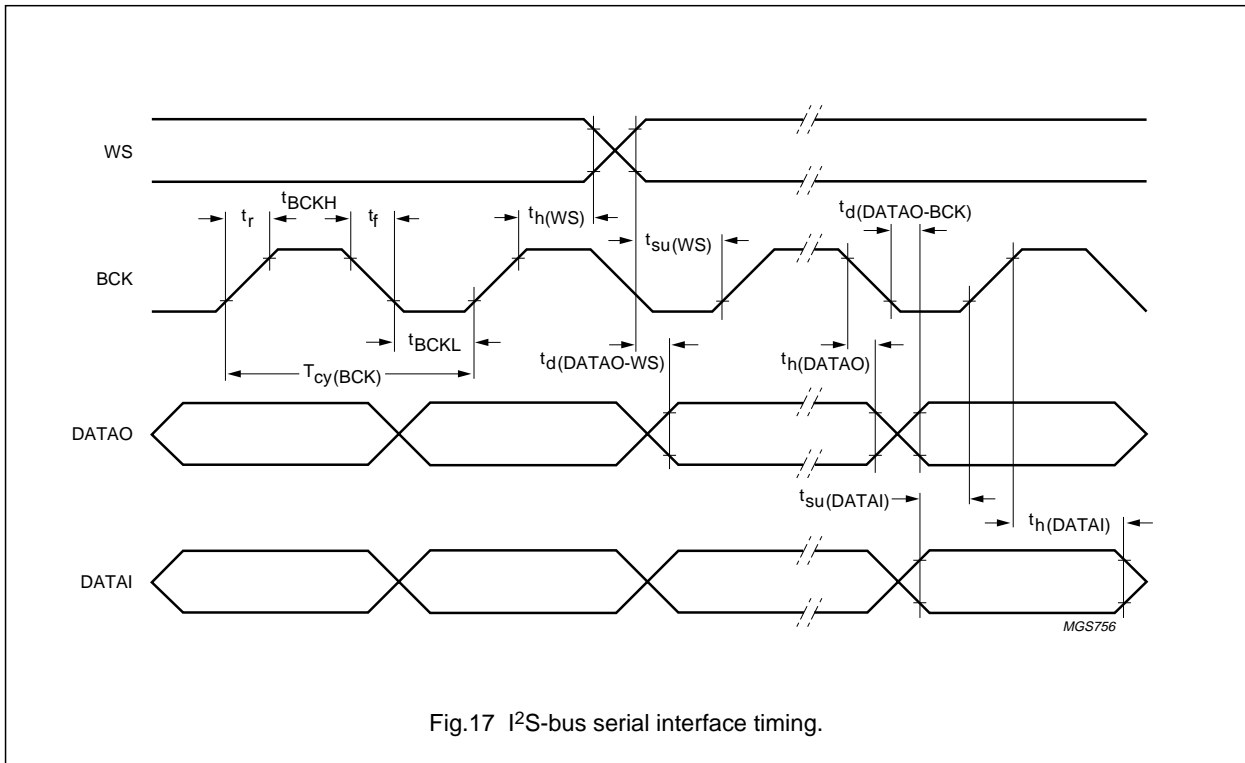

Fig.17 I²S-bus serial interface timing.

Multichannel audio coder-decoder

UDA1338H

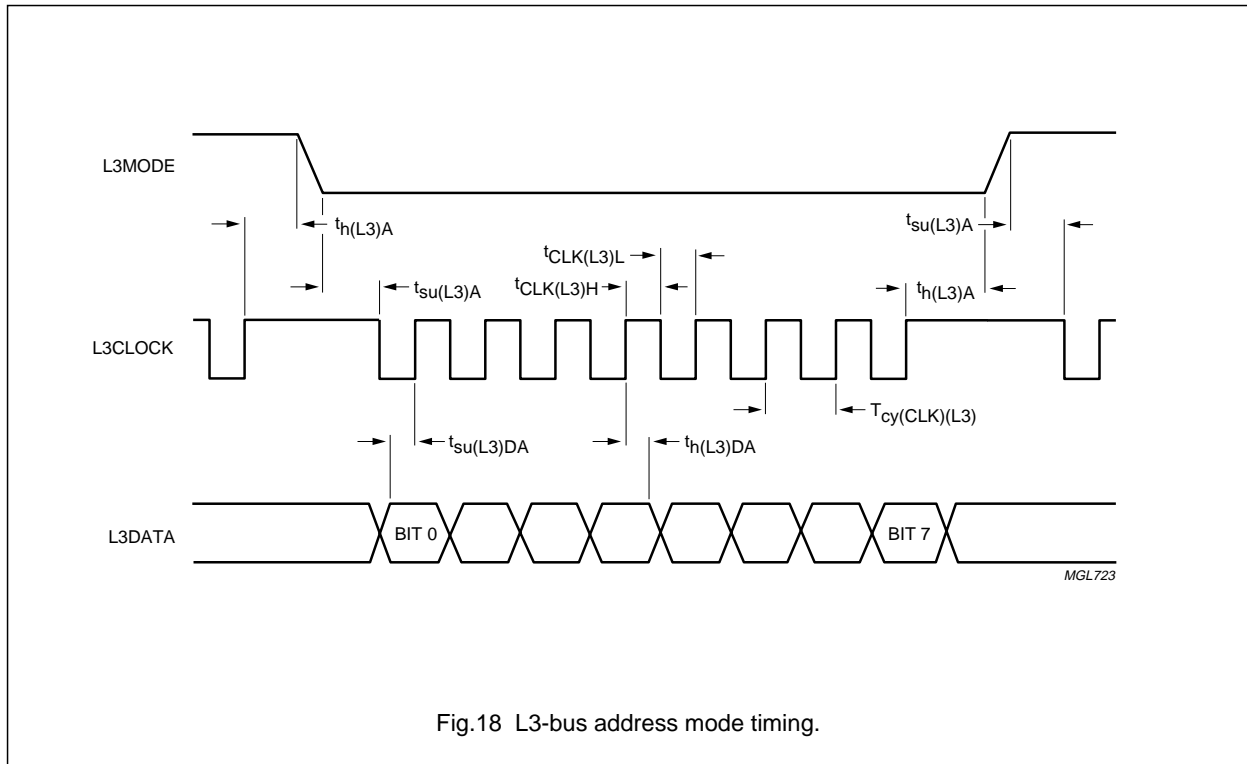

Fig.18 L3-bus address mode timing.

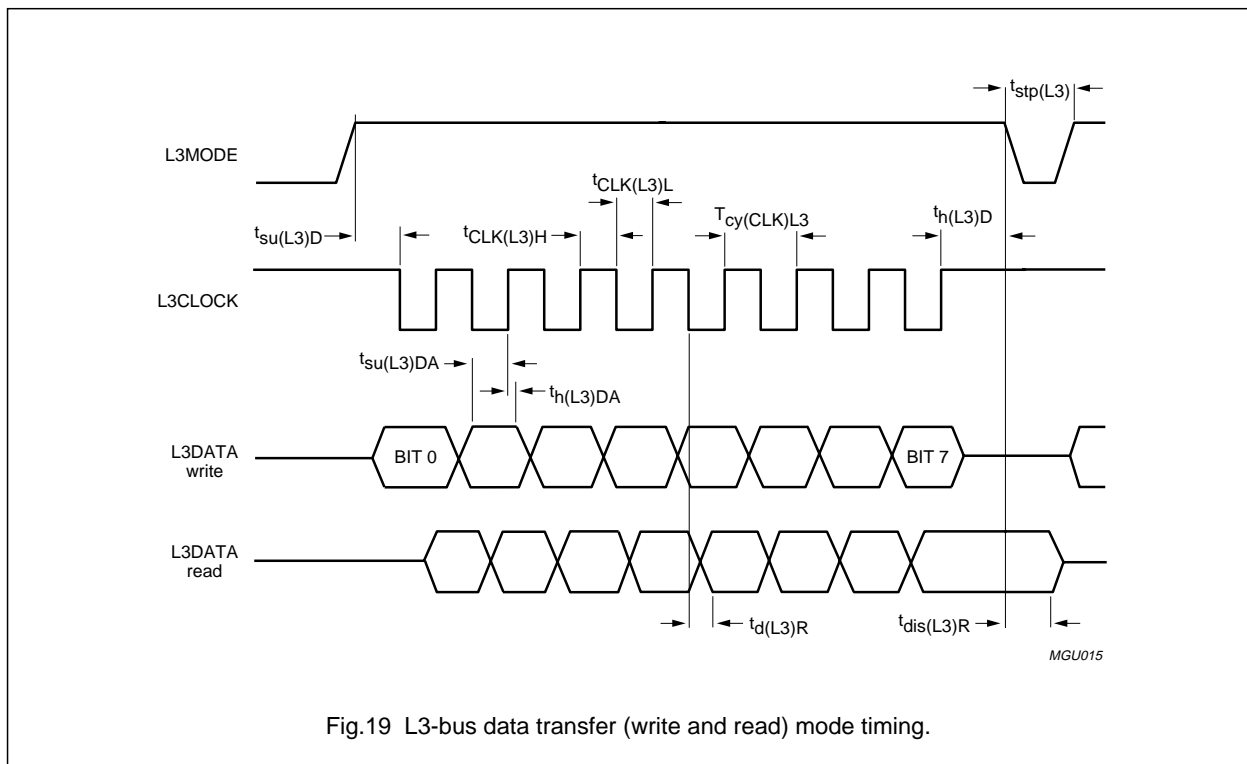

Fig.19 L3-bus data transfer (write and read) mode timing.

Multichannel audio coder-decoder

UDA1338H

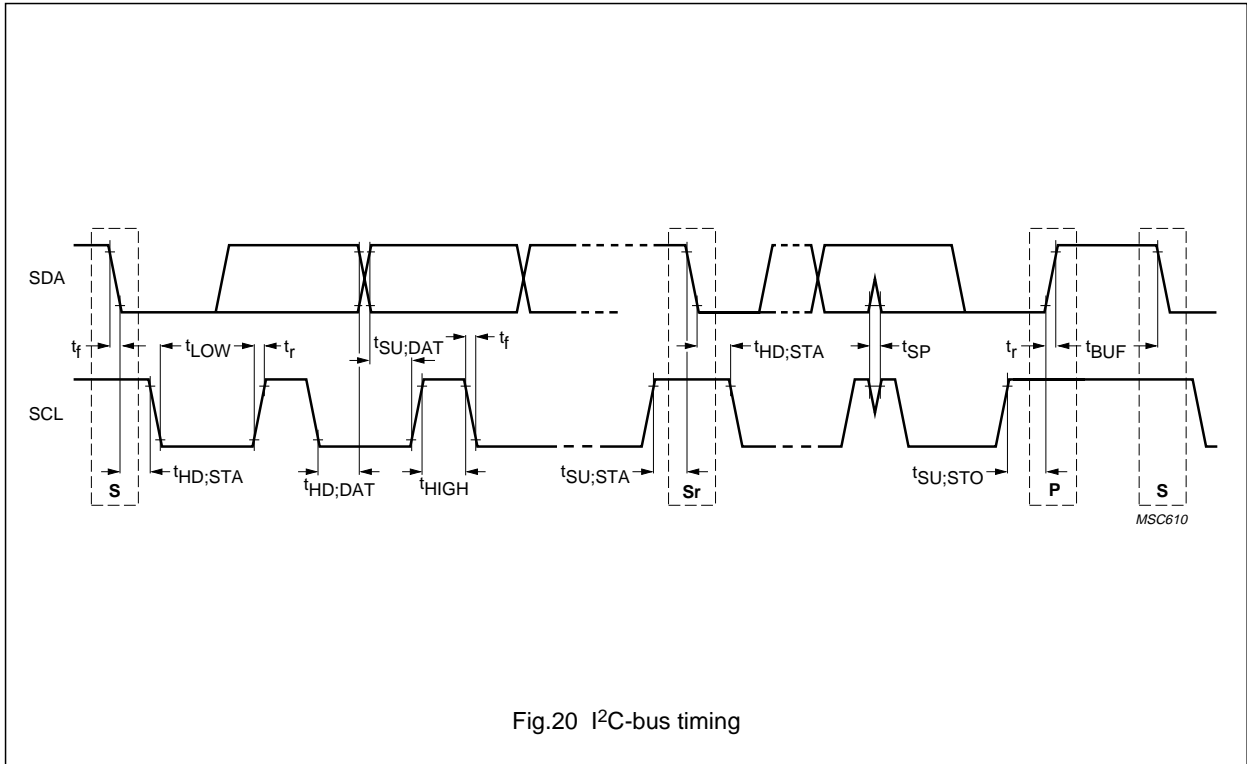

Fig.20 I²C-bus timing

Multichannel audio coder-decoder

UDA1338H

19 PACKAGE OUTLINE

QFP44: plastic quad flat package; 44 leads (lead length 1.3 mm); body 10 x 10 x 1.75 mm

SOT307-2

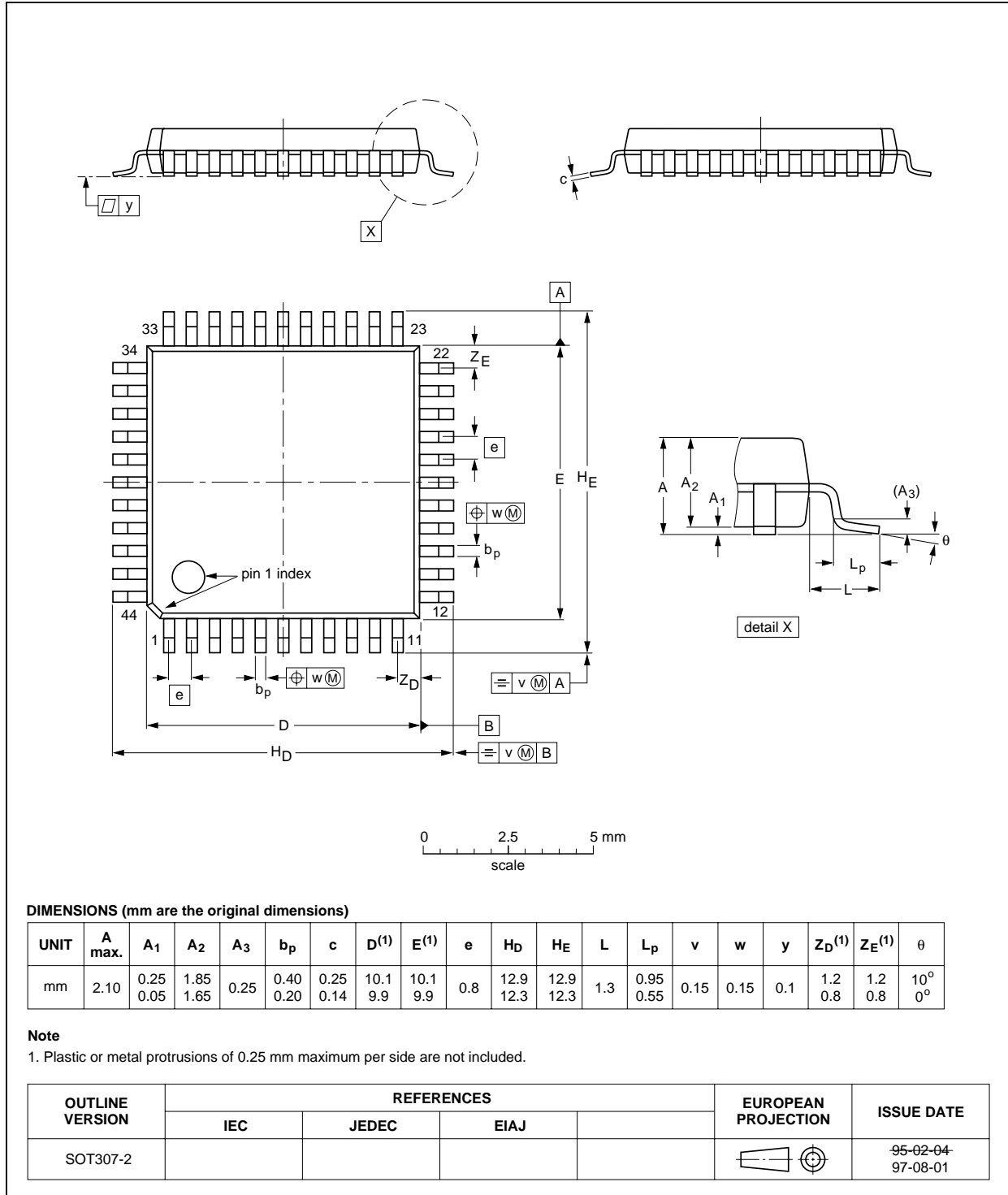

Multichannel audio coder-decoder

UDA1338H

20 SOLDERING

20.1 Introduction to soldering surface mount packages

This text gives a very brief insight to a complex technology. A more in-depth account of soldering ICs can be found in our *"Data Handbook IC26; Integrated Circuit Packages"* (document order number 9398 652 90011).

There is no soldering method that is ideal for all surface mount IC packages. Wave soldering can still be used for certain surface mount ICs, but it is not suitable for fine pitch SMDs. In these situations reflow soldering is recommended.

20.2 Reflow soldering

Reflow soldering requires solder paste (a suspension of fine solder particles, flux and binding agent) to be applied to the printed-circuit board by screen printing, stencilling or pressure-syringe dispensing before package placement.

Several methods exist for reflowing; for example, convection or convection/infrared heating in a conveyor type oven. Throughput times (preheating, soldering and cooling) vary between 100 and 200 seconds depending on heating method.

Typical reflow peak temperatures range from 215 to 250 °C. The top-surface temperature of the packages should preferably be kept below 220 °C for thick/large packages, and below 235 °C for small/thin packages.

20.3 Wave soldering

Conventional single wave soldering is not recommended for surface mount devices (SMDs) or printed-circuit boards with a high component density, as solder bridging and non-wetting can present major problems.

To overcome these problems the double-wave soldering method was specifically developed.

If wave soldering is used the following conditions must be observed for optimal results:

- Use a double-wave soldering method comprising a turbulent wave with high upward pressure followed by a smooth laminar wave.
- For packages with leads on two sides and a pitch (e):
 - larger than or equal to 1.27 mm, the footprint longitudinal axis is **preferred** to be parallel to the transport direction of the printed-circuit board;
 - smaller than 1.27 mm, the footprint longitudinal axis **must** be parallel to the transport direction of the printed-circuit board.

The footprint must incorporate solder thieves at the downstream end.

- For packages with leads on four sides, the footprint must be placed at a 45° angle to the transport direction of the printed-circuit board. The footprint must incorporate solder thieves downstream and at the side corners.

During placement and before soldering, the package must be fixed with a droplet of adhesive. The adhesive can be applied by screen printing, pin transfer or syringe dispensing. The package can be soldered after the adhesive is cured.

Typical dwell time is 4 seconds at 250 °C.

A mildly-activated flux will eliminate the need for removal of corrosive residues in most applications.

20.4 Manual soldering

Fix the component by first soldering two diagonally-opposite end leads. Use a low voltage (24 V or less) soldering iron applied to the flat part of the lead. Contact time must be limited to 10 seconds at up to 300 °C.

When using a dedicated tool, all other leads can be soldered in one operation within 2 to 5 seconds between 270 and 320 °C.

Multichannel audio coder-decoder

UDA1338H

20.5 Suitability of surface mount IC packages for wave and reflow soldering methods

PACKAGE ⁽¹⁾	SOLDERING METHOD	
	WAVE	REFLOW ⁽²⁾
BGA, LBGA, LFBGA, SQFP, TFBGA, VFBGA	not suitable	suitable
HBCC, HBGA, HLQFP, HSQFP, HSOP, HTQFP, HTSSOP, HVQFN, HVSON, SMS	not suitable ⁽³⁾	suitable
PLCC ⁽⁴⁾ , SO, SOJ	suitable	suitable
LQFP, QFP, TQFP	not recommended ⁽⁴⁾⁽⁵⁾	suitable
SSOP, TSSOP, VSO	not recommended ⁽⁶⁾	suitable

Notes

1. For more detailed information on the BGA packages refer to the “(LF)BGA Application Note” (AN01026); order a copy from your Philips Semiconductors sales office.
2. All surface mount (SMD) packages are moisture sensitive. Depending upon the moisture content, the maximum temperature (with respect to time) and body size of the package, there is a risk that internal or external package cracks may occur due to vaporization of the moisture in them (the so called popcorn effect). For details, refer to the Drypack information in the “Data Handbook IC26; Integrated Circuit Packages; Section: Packing Methods”.
3. These packages are not suitable for wave soldering. On versions with the heatsink on the bottom side, the solder cannot penetrate between the printed-circuit board and the heatsink. On versions with the heatsink on the top side, the solder might be deposited on the heatsink surface.
4. If wave soldering is considered, then the package must be placed at a 45° angle to the solder wave direction. The package footprint must incorporate solder thieves downstream and at the side corners.
5. Wave soldering is suitable for LQFP, TQFP and QFP packages with a pitch (e) larger than 0.8 mm; it is definitely not suitable for packages with a pitch (e) equal to or smaller than 0.65 mm.
6. Wave soldering is suitable for SSOP and TSSOP packages with a pitch (e) equal to or larger than 0.65 mm; it is definitely not suitable for packages with a pitch (e) equal to or smaller than 0.5 mm.

Multichannel audio coder-decoder

UDA1338H

21 DATA SHEET STATUS

LEVEL	DATA SHEET STATUS ⁽¹⁾	PRODUCT STATUS ⁽²⁾⁽³⁾	DEFINITION
I	Objective data	Development	This data sheet contains data from the objective specification for product development. Philips Semiconductors reserves the right to change the specification in any manner without notice.
II	Preliminary data	Qualification	This data sheet contains data from the preliminary specification. Supplementary data will be published at a later date. Philips Semiconductors reserves the right to change the specification without notice, in order to improve the design and supply the best possible product.
III	Product data	Production	This data sheet contains data from the product specification. Philips Semiconductors reserves the right to make changes at any time in order to improve the design, manufacturing and supply. Relevant changes will be communicated via a Customer Product/Process Change Notification (CPCN).

Notes

1. Please consult the most recently issued data sheet before initiating or completing a design.
2. The product status of the device(s) described in this data sheet may have changed since this data sheet was published. The latest information is available on the Internet at URL <http://www.semiconductors.philips.com>.
3. For data sheets describing multiple type numbers, the highest-level product status determines the data sheet status.

22 DEFINITIONS

Short-form specification — The data in a short-form specification is extracted from a full data sheet with the same type number and title. For detailed information see the relevant data sheet or data handbook.

Limiting values definition — Limiting values given are in accordance with the Absolute Maximum Rating System (IEC 60134). Stress above one or more of the limiting values may cause permanent damage to the device. These are stress ratings only and operation of the device at these or at any other conditions above those given in the Characteristics sections of the specification is not implied. Exposure to limiting values for extended periods may affect device reliability.

Application information — Applications that are described herein for any of these products are for illustrative purposes only. Philips Semiconductors make no representation or warranty that such applications will be suitable for the specified use without further testing or modification.

23 DISCLAIMERS

Life support applications — These products are not designed for use in life support appliances, devices, or systems where malfunction of these products can reasonably be expected to result in personal injury. Philips Semiconductors customers using or selling these products for use in such applications do so at their own risk and agree to fully indemnify Philips Semiconductors for any damages resulting from such application.

Right to make changes — Philips Semiconductors reserves the right to make changes in the products - including circuits, standard cells, and/or software - described or contained herein in order to improve design and/or performance. When the product is in full production (status 'Production'), relevant changes will be communicated via a Customer Product/Process Change Notification (CPCN). Philips Semiconductors assumes no responsibility or liability for the use of any of these products, conveys no licence or title under any patent, copyright, or mask work right to these products, and makes no representations or warranties that these products are free from patent, copyright, or mask work right infringement, unless otherwise specified.

Multichannel audio coder-decoder**UDA1338H**

24 PURCHASE OF PHILIPS I²C COMPONENTS

Purchase of Philips I²C components conveys a license under the Philips' I²C patent to use the components in the I²C system provided the system conforms to the I²C specification defined by Philips. This specification can be ordered using the code 9398 393 40011.

Multichannel audio coder-decoder

UDA1338H

NOTES

Multichannel audio coder-decoder

UDA1338H

NOTES

Multichannel audio coder-decoder

UDA1338H

NOTES

Philips Semiconductors – a worldwide company

Contact information

For additional information please visit <http://www.semiconductors.philips.com>. Fax: **+31 40 27 24825**

For sales offices addresses send e-mail to: sales.addresses@www.semiconductors.philips.com.

© Koninklijke Philips Electronics N.V. 2002

SCA74

All rights are reserved. Reproduction in whole or in part is prohibited without the prior written consent of the copyright owner.

The information presented in this document does not form part of any quotation or contract, is believed to be accurate and reliable and may be changed without notice. No liability will be accepted by the publisher for any consequence of its use. Publication thereof does not convey nor imply any license under patent- or other industrial or intellectual property rights.

Printed in The Netherlands

753503/2/pp56

Date of release: 2002 Nov 21

Document order number: 9397 750 10089

Let's make things better.

**Philips
Semiconductors**



PHILIPS