

DATA SHEET



TZA1020; TZA1020A Pre-amplifiers for CD-RW systems

Product specification
File under Integrated Circuits, IC01

2000 Oct 30

Pre-amplifiers for CD-RW systems

TZA1020; TZA1020A

CONTENTS	9	LIMITING VALUES
1 FEATURES	10	THERMAL CHARACTERISTICS
2 GENERAL DESCRIPTION	11	CHARACTERISTICS
3 QUICK REFERENCE DATA	11.1	Transfer functions for normalized servo signals
4 ORDERING INFORMATION	11.2	Laser power control signals (alpha circuit)
5 BLOCK DIAGRAM	11.3	Wobble pre-processor
6 PINNING	12	APPLICATION AND TEST INFORMATION
7 FUNCTIONAL DESCRIPTION	13	PACKAGE OUTLINE
7.1 Data amplifier	14	SOLDERING
7.2 Normalizer	14.1	Introduction to soldering surface mount packages
7.3 Wobble pre-processor	14.2	Reflow soldering
7.4 Beta detector	14.3	Wave soldering
7.5 Alpha detector	14.4	Manual soldering
7.6 Fast track count	14.5	Suitability of surface mount IC packages for wave and reflow soldering methods
7.7 Spot position measurement		
8 I ² C-BUS PROTOCOL	15	DATA SHEET STATUS
8.1 Addressing and data bytes	16	DEFINITIONS
8.1.1 Write mode	17	DISCLAIMERS
8.1.2 Read mode	18	PURCHASE OF PHILIPS I ² C COMPONENTS
8.1.3 Control byte subaddress 00		
8.1.4 Control byte subaddress 01		
8.1.5 Control byte subaddress 02		
8.1.6 Control byte subaddress 03		
8.1.7 Control byte subaddress 04		
8.1.8 Control byte subaddress 05		
8.1.9 Control byte subaddress 06		
8.1.10 Control byte subaddress 07		
8.2 Characteristics of the I ² C-bus		

Pre-amplifiers for CD-RW systems

TZA1020; TZA1020A

1 FEATURES

- Data amplifier for read speed up to twelve times nominal data speed
- Normalized and filtered error signals for servo control
- Wobble pre-processor with switchable low-pass filter
- Calculation of signals for real-time laser power control for write speed up to four times
- Calculation of signals for optimum laser calibration for write speed up to four times
- Fast track count amplifier
- Spot position measurement for alignment of photo diodes
- Reference voltage for laser controller
- On-chip band gap and DACs for accurate and adjustable current/gain settings
- I²C-bus microcontroller interface for programmable gain, speed switching and function selection
- All functions available for CD-R and CD-RW systems.

**2 GENERAL DESCRIPTION**

TZA1020 (AEGER2) is an analog pre-processor IC for CD-R and CD-RW systems with 3-spots push-pull tracking system. The IC interfaces directly to the photo diodes. The device generates signals for laser power calibration and laser power control during disc writing. Normalized error signals are generated for servo control and wobble detection. An HF current amplifier is implemented to detect the actual HF data signal. The Fast Track Count (FTC) amplifier generates a radial error signal to allow fast track counting.

TZA1020A (AEGER2A) is similar to the TZA1020, except for non-clamped MIRR, which allows operation with IGUANA.

3 QUICK REFERENCE DATA

SYMBOL	PARAMETER	CONDITIONS	MIN.	TYP.	MAX.	UNIT
V _{DD}	positive supply voltage		4.5	5.0	5.5	V
V _{SS}	negative supply voltage		-5.5	-5.0	-4.5	V
I _{i(cd)}	central diode input current range		0	-	4000	μA
B _{-3dB(norm)}	-3 dB bandwidth normalized error signals (servo)		48	60	-	kHz
B _{-3dB(CAHF)}	-3 dB bandwidth pin CAHF	C _i = 12 pF	17	-	-	MHz
Δt _{d(g)(CAHF)}	group delay variations pin CAHF	f = 0.1 to 12 MHz; C _i = 12 pF	-	-	0.9	ns
G _{I(CAHF)}	current gain pin CAHF	cdrwsel = 1	-	35	-	
		cdrwsel = 0	-	8.75	-	
I _{RREF}	reference current		-	-900	-	μA
T _{amb}	ambient temperature		0	-	70	°C

4 ORDERING INFORMATION

TYPE NUMBER	PACKAGE		
	NAME	DESCRIPTION	VERSION
TZA1020HP; TZA1020HP/A	QFP44	plastic quad flat package; 44 leads (lead length 1.3 mm); body 10 × 10 × 1.75 mm	SOT307-2

Pre-amplifiers for CD-RW systems

TZA1020; TZA1020A

5 BLOCK DIAGRAM

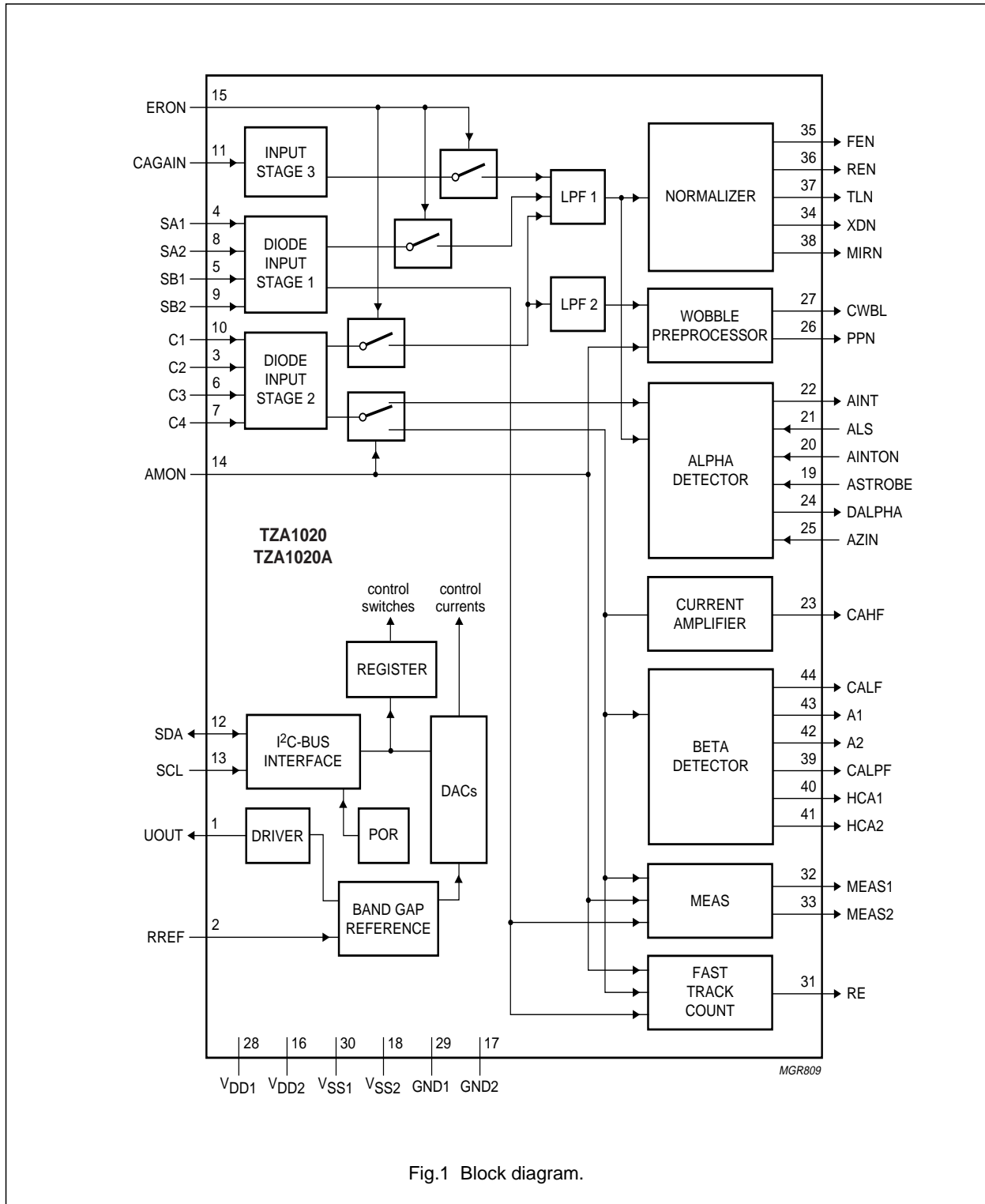

Fig.1 Block diagram.

Pre-amplifiers for CD-RW systems

TZA1020; TZA1020A

6 PINNING

SYMBOL	PIN	DESCRIPTION
UOUT	1	reference voltage output
RREF	2	reference current input
C2	3	central photo diode current input
SA1	4	satellite photo diode current input
SB1	5	satellite photo diode current input
C3	6	central photo diode current input
C4	7	central photo diode current input
SA2	8	satellite photo diode current input
SB2	9	satellite photo diode current input
C1	10	central photo diode current input
CAGAIN	11	set-point laser power on disc, current input
SDA	12	I ² C-bus data input/output
SCL	13	I ² C-bus clock input
AMON	14	alpha measurement on switch (write/read state)
ERON	15	normalized error signals on switch
V _{DD2}	16	positive supply voltage 2
GND2	17	ground 2
V _{SS2}	18	negative supply voltage 2
ASTROBE	19	control signal sample-and-hold in alpha measurement
AINTON	20	control signal integrator in alpha measurement
ALS	21	DALPHA output enabled/disabled
AINT	22	integrator capacitor for alpha measurement
CAHF	23	central aperture high-frequency current output
DALPHA	24	alpha error signal for laser power control
AZIN	25	set-point alpha control

SYMBOL	PIN	DESCRIPTION
PPN	26	normalized, balanced push-pull signal voltage
CWBL	27	capacitor for EFM noise reduction loop
V _{DD1}	28	positive supply voltage 1
GND1	29	ground 1
V _{SS1}	30	negative supply voltage 1
RE	31	fast track count signal voltage output
MEAS1	32	combination of photo diode currents for adjustment 1
MEAS2	33	combination of photo diode currents for adjustment 2
XDN	34	normalized spot position error current output
FEN	35	normalized focus error current output
REN	36	normalized radial error current output
TLN	37	normalized track-loss current output
MIRN	38	mirror output (disc reflection) current output
CALPF	39	capacitor to define CALF bandwidth
HCA1	40	capacitor to define time constant peak detector A1
HCA2	41	capacitor to define time constant peak detector A2
A2	42	pit amplitude relative to CALF, voltage output
A1	43	land amplitude relative to CALF, voltage output
CALF	44	low-pass filtered aperture signal, voltage output

Pre-amplifiers for CD-RW systems

TZA1020; TZA1020A

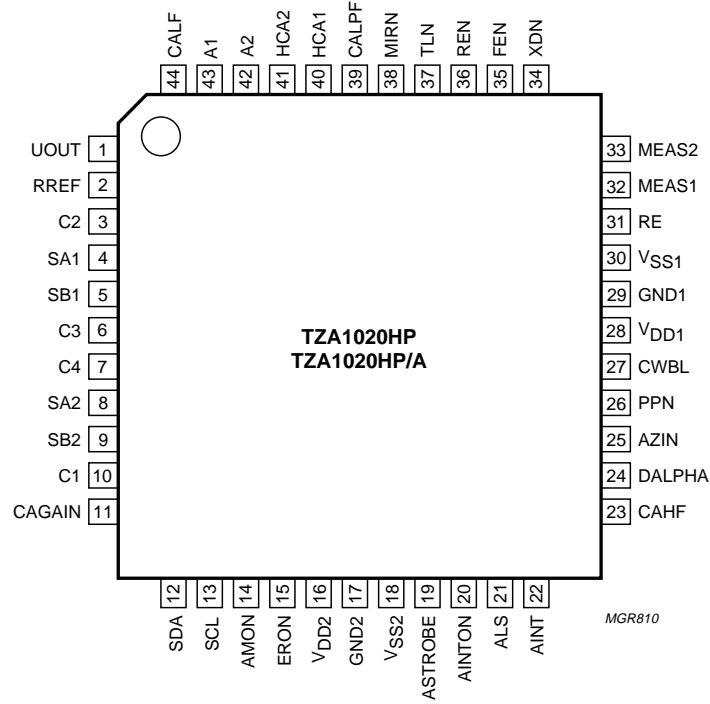

Fig.2 Pin configuration.

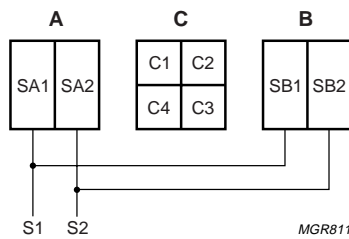

Fig.3 Quadrant diode configuration.

Pre-amplifiers for CD-RW systems

TZA1020; TZA1020A

7 FUNCTIONAL DESCRIPTION

All functions are designed in such a way that a read speed up to twelve times nominal speed is possible ($N = 1, 2, 4, 8$ or 12). Recording speed up to four is possible ($N = 1, 2$ or 4). The maximum recording speed must be determined.

7.1 Data amplifier

The central diodes currents (C1 to C4) are fed to a high bandwidth current amplifier. The gain of the current amplifier can be switched by means of the I²C-bus microcontroller interface to compensate for differences in CD-R and CD-RW disc reflection. Data signals up to twelve times nominal data speed can be read.

7.2 Normalizer

The currents from the central diodes (C1 to C4), the current from the satellite diodes (SA1, SA2, SB1 and SB2) and the laser set-point current (CAGAIN) are (optionally sampled) fed to the first low-pass filters with a bandwidth of 60 kHz. The normalizing circuit generates error signals for servo control that are independent of the diode current level. The gain of the error signals is controlled by the I²C-bus microcontroller interface. A dropout concealment becomes active if the input current level is below a certain threshold value. This threshold value is also controlled by the I²C-bus.

7.3 Wobble pre-processor

The wobble signal of the pre-groove is detected by means of the PPN signal. The currents from inputs C1 to C4 are filtered and processed to provide optimal signal-to-noise ratio. The bandwidth of the filter may be adapted to the disc speed via the I²C-bus. The bandwidth of a noise reduction loop is controlled by an external capacitor, the I²C-bus interface controls the total operation of the processor.

7.4 Beta detector

The beta detector generates signals necessary for the symmetry detection of the HF signal. By measuring peak values (A1 and A2) and average value of the signal (CALF), an optimum laser writing power can be determined. The gain of the measured values is controlled by the I²C-bus. The time constant of the peak detectors and bandwidth of the low-pass filtered aperture signal can also be adapted to the disc speed by the I²C-bus.

7.5 Alpha detector

The alpha detector determines a parameter called 'alpha' during disc writing. Alpha must be kept constant to allow recording over a fingerprint or black dot. The definition of alpha is different for CD-R and CD-RW; for CD-R the light absorption of the disc is measured, for CD-RW alpha is determined by actual laser power and disc reflection. The gain of the measured signals and the CD-R and CD-RW selection is performed by the I²C-bus.

7.6 Fast track count

The fast track count circuit generates a Radial Error (RE) signal for fast track counting. A gain switch compensates for difference in CD-R and CD-RW disc reflection.

7.7 Spot position measurement

To allow alignment of photo diodes via the TZA1020, a number of linear combinations of input currents can be realized (MEAS1 and MEAS2). Selection of the actual combination is performed by the I²C-bus.

Pre-amplifiers for CD-RW systems

TZA1020; TZA1020A

8 I²C-BUS PROTOCOL**8.1 Addressing and data bytes**

Full control of the TZA1020 is accomplished via the 2-wire I²C-bus. Up to 400 kbits/s bus speed can be used in accordance with the I²C-bus fast-mode specification.

For programming the device (write mode) eight data byte registers are available/addressable via eight subaddresses. Automatic subaddress incrementing enables the writing of successive data bytes in one transmission. During power-on, data byte registers are reset to a default state by use of a Power-On Reset (POR) circuit whose signal is derived from the internally generated I²C-bus supply voltage (V_{SS1}).

For reading from the device (read mode) one data byte register is available without subaddressing.

8.1.1 WRITE MODE

Table 1 Slave address; 34H

Slave address	0	0	1	1	0	1	0	0
---------------	---	---	---	---	---	---	---	---

Table 2 Subaddress 00H to 07H

Subaddress	0 ⁽¹⁾	0 ⁽¹⁾	0 ⁽¹⁾	0 ⁽¹⁾	0	0/1	0/1	0/1
------------	------------------	------------------	------------------	------------------	---	-----	-----	-----

Note

- The use of subaddresses F0H to F7H (11110XXX) instead of 00H to 07H (00000XXX) disables the automatic subaddress incrementing allowing continuous writing to a single data byte register (e.g. DAC testing).

Table 3 Overview of subaddresses

SUB ADDR	POR STATE	DATA BYTES							
00H	00000000	alphactr2	alphactr1	alphactr0	alphagain4	alphagain3	alphagain2	alphagain1	alphagain0
01H	00000000	free	algctr6	algctr5	algctr4	algctr3	algctr2	algctr1	algctr0
02H	00000000	tlngain1	tlngain0	rengain	negain4	negain3	negain2	negain1	negain0
03H	00000000	tmdac	tlnlm1	tlnlm0	sumref4	sumref3	sumref2	sumref1	sumref0
04H	00000000	sdfine7	sdfine6	sdfine5	sdfine4	sdfine3	sdfine2	sdfine1	sdfine0
05H	00011111	lexton	betactrl1	betactrl0	betascl4	betascl3	betascl2	betascl1	betascl0
06H	01100000	free	ppnctr11	ppnctr10	ppnscl4	ppnscl3	ppnscl2	ppnscl1	ppnscl0
07H	00000000	porr	free	urefsel	cdrwsel	lpsel1	lpsel0	meassel1	meassel0

8.1.2 READ MODE

Table 4 Slave address; 35H

Slave address	0	0	1	1	0	1	0	1
---------------	---	---	---	---	---	---	---	---

Table 5 Read byte

Read byte	por ⁽¹⁾	0 ⁽²⁾	0 ⁽²⁾	0 ⁽²⁾	0 ⁽²⁾	0 ⁽²⁾	0 ⁽²⁾	0 ⁽²⁾
-----------	--------------------	------------------	------------------	------------------	------------------	------------------	------------------	------------------

Notes

- In read mode the actual POR status can be read.
- The state of unused read bits should not be relied upon; their state may be changed during development.

Pre-amplifiers for CD-RW systems

TZA1020; TZA1020A

8.1.2.1 Examples of valid transmissions to and from the TZA1020

Write: START - 34H - 00H - Data_for_00 - STOP

Write with auto-increment: START - 34H - 00H - data_for_00 - data_for_01 - data_for_02 - STOP

Auto-increment 'wrap around': START - 34H - 07H - data_for_07 - data_for_00 - data_for_01 - STOP

Write without auto-increment: START - 34H - F5H - data_for_05 - data_for_05 - data_for_05 - STOP

Read: START - 35H - data_from_IC - STOP.

8.1.3 CONTROL BYTE SUBADDRESS 00

Table 6 Control bits for alphactrl

alphactrl2	alphactrl1	alphactrl0	GAIN INPUT CURRENT ALPHA DETECTOR
0	0	0	0.50
0	0	1	0.33
0	1	0	0.25
0	1	1	0.20
1	0	0	0.17
1	0	1	0.14
1	1	0	0.12
1	1	1	0.11

Table 7 Control bits for alphagain-DAC; note 1

alphagain4	alphagain3	alphagain2	alphagain1	alphagain0	CURRENT alphagain-DAC
0	0	0	0	0	3.125 μ A
0	0	0	0	1	6.250 μ A
0	0	0	1	0	9.375 μ A
: code					:
					100 μ A (code + 1)/32
1	1	1	0	1	93.750 μ A
1	1	1	1	0	96.900 μ A
1	1	1	1	1	100 μ A

Note

1. The currents of all DACs is controlled by reference current (I_{RREF}). The given currents are valid at $I_{\text{RREF}} = -900 \mu\text{A}$.

Pre-amplifiers for CD-RW systems

TZA1020; TZA1020A

8.1.4 CONTROL BYTE SUBADDRESS 01

Table 8 Control byte for algctrl switch functions

algctr6	algctr5	algctr4	algctr3	algctr2	algctr1	algctr0	DESCRIPTION
0	0	0	0	0	0	0	POR state
0	–	0	–	–	–	–	current gain alpha CD-R Aoc = 0alpha CD-R circuit power-off
0	–	1	–	–	–	–	current gain alpha CD-R Aoc = 1alpha CD-R circuit power-on
1	–	0	–	–	–	–	current gain alpha CD-R Aoc = 3alpha CD-R circuit power-off
1	–	1	–	–	–	–	current gain alpha CD-R Aoc = 4alpha CD-R circuit power-on
–	0	–	–	–	–	–	alpha peak detector normal mode
–	1	–	–	–	–	–	alpha peak detector to level (test)
–	–	–	0	–	–	–	CD-RW mode 1
–	–	–	1	–	–	–	CD-RW mode 2
–	–	–	–	0	–	–	alpha CD-R
–	–	–	–	1	–	–	alpha CD-RW
–	–	–	–	–	0	0	DALPHA gain = 0.25
–	–	–	–	–	0	1	DALPHA gain = 0.50
–	–	–	–	–	1	0	DALPHA gain = 0.75
–	–	–	–	–	1	1	DALPHA gain = 1.00

8.1.5 CONTROL BYTE SUBADDRESS 02

Table 9 Control bits for tlngain

tlngain1	tlngain0	GAIN TLN SIGNAL
0	0	1.5
0	1	3.0
1	0	4.5
1	1	6.0

Table 10 Control bits for rengain

rengain	DESCRIPTION
0	1 normal
1	1.3 self test

Pre-amplifiers for CD-RW systems

TZA1020; TZA1020A

Table 11 Control bits for current negain-DAC; note 1

negain4	negain3	negain2	negain1	negain0	CURRENT negain-DAC
0	0	0	0	0	3.125 μ A
0	0	0	0	1	6.250 μ A
0	0	0	1	0	9.375 μ A
:					:
code					$100 \mu\text{A} (\text{code} + 1)/32$
1	1	1	0	1	93.750 μ A
1	1	1	1	0	96.900 μ A
1	1	1	1	1	100 μ A

Note

- The currents of all DACs is controlled by reference current (I_{RREF}). The given currents are valid at $I_{\text{RREF}} = -900 \mu\text{A}$.

8.1.6 CONTROL BYTE SUBADDRESS 03

Table 12 Control bit for tmdac

tmdac	DESCRIPTION
0	DAC test off
1	DAC test on

Table 13 Control bits for tlnlimit

tlnlim1	tlnlim0	DESCRIPTION
0	0	clamp off
X	1	clamp on 1 (0.6 V; $T_{\text{amb}} = 25^\circ\text{C}$)
1	0	clamp on 2 (1.2 V; $T_{\text{amb}} = 25^\circ\text{C}$)

Table 14 Control bits for current sumref-DAC; note 1

sumref4	sumref3	sumref2	sumref1	sumref0	CURRENT sumref-DAC
0	0	0	0	0	0.468 μ A
0	0	0	0	1	0.937 μ A
0	0	0	1	0	1.40 μ A
:					:
code					$15 \mu\text{A} (\text{code} + 1)/32$
1	1	1	0	1	14.06 μ A
1	1	1	1	0	14.53 μ A
1	1	1	1	1	15.00 μ A

Note

- The currents of all DACs is controlled by reference current (I_{RREF}). The given currents are valid at $I_{\text{RREF}} = -900 \mu\text{A}$.

Pre-amplifiers for CD-RW systems

TZA1020; TZA1020A

8.1.7 CONTROL BYTE SUBADDRESS 04

Table 15 Control byte for 8-bit sdfine-DAC; note 1

sdfine7	sdfine6	sdfine5	sdfine4	sdfine3	sdfine2	sdfine1	sdfine0	CURRENT sdfine-DAC
0	0	0	0	0	0	0	0	0.117 μ A
0	0	0	0	0	0	0	1	0.234 μ A
0	0	0	0	0	0	1	0	0.352 μ A
:								:
code								30 μ A (code + 1)/256
1	1	1	1	1	1	0	1	29.76 μ A
1	1	1	1	1	1	1	0	29.88 μ A
1	1	1	1	1	1	1	1	30.0 μ A

Note

- The currents of all DACs is controlled by reference current (I_{RREF}). The given currents are valid at $I_{\text{RREF}} = -900 \mu\text{A}$.

8.1.8 CONTROL BYTE SUBADDRESS 05

Table 16 Control bits for betactrl control via 5-bit DAC

betactrl1	betactrl0	CALF BANDWIDTH (Hz)
0	0	500
0	1	1000
1	0	2000
1	1	4000

Table 17 Control bits for betascl control via 5-bit DAC; note 1

betascl4	betascl3	betascl2	betascl1	betascl0	CURRENT betascl-DAC
0	0	0	0	0	3.125 μ A
0	0	0	0	1	6.250 μ A
0	0	0	1	0	9.375 μ A
:					:
code					100 μ A (code + 1)/32
1	1	1	0	1	93.750 μ A
1	1	1	1	0	96.900 μ A
1	1	1	1	1	100 μ A

Note

- The currents of all DACs is controlled by reference current (I_{RREF}). The given currents are valid at $I_{\text{RREF}} = -900 \mu\text{A}$.

Pre-amplifiers for CD-RW systems

TZA1020; TZA1020A

8.1.9 CONTROL BYTE SUBADDRESS 06

Table 18 Control bits for ppnctrl control via 5-bit DAC

ppnctrl1	ppnctrl0	DESCRIPTION
1	1	POR state
–	0	integrator slow disabled
–	1	integrator slow enabled
0	–	integrator fast disabled
1	–	integrator fast enabled

Table 19 Control bits for ppnscl control via 5-bit DAC; note 1

ppnscl4	ppnscl3	ppnscl2	ppnscl1	ppnscl0	CURRENT ppnscl-DAC
0	0	0	0	0	3.125 μ A
0	0	0	0	1	6.250 μ A
0	0	0	1	0	9.375 μ A
: code					:
					100 μ A (code + 1)/32
1	1	1	0	1	93.750 μ A
1	1	1	1	0	96.900 μ A
1	1	1	1	1	100 μ A

Note

- The currents of all DACs is controlled by reference current (I_{RREF}). The given currents are valid at $I_{RREF} = -900 \mu\text{A}$.

8.1.10 CONTROL BYTE SUBADDRESS 07

Table 20 Control bits for porr

porr	MODE	DESCRIPTION
0	note 1	
1	POR reset	reset of POR signal bit

Note

- When porr is set to logic 1 it ensures that the POR read bit is reset to logic 0. This way a reading of POR is always at logic 1 with the occurrence of an actual power-on I²C-bus register reset and cannot accidentally be caused by other I²C-bus control bits. Bit porr has no control function; it is an 'unused' bit dedicated by name to change the I²C-bus register content from the POR state. Bit POR of the read byte is a wired NOR function that checks all I²C-bus register bits: when the I²C-bus register contents equals the Power-on reset default state POR will read logic 1, also when this state is set via the I²C-bus control. Because a setting of porr = 1 differs from the POR default state it forces a reset to logic 0 of the POR bit independent of other bit settings.

Pre-amplifiers for CD-RW systems

TZA1020; TZA1020A

Table 21 Control bits for meassel

meassel1	meassel0	MEAS1	MEAS2
0	0	$Gc [(lc1 + lc4) - (lc2 + lc3)]$	$Gc [(lc1 + lc2) - (lc3 + lc4)]$
0	1	$Gs (la1 - la2)$	$Gs (lb2 - lb1)$
1	0	$Gs (la1 + lb1)$	$Gs (la2 + lb2)$
1	1	$Gs (la1 + la2)$	$Gs (lb2 + lb1)$

Table 22 Control bits for lpsel

lpsel1	lpsel0	BANDWIDTH
0	0	40 kHz
0	1	80 kHz
1	0	160 kHz
1	1	320 kHz

Table 23 Control bit for cdrwsel

cdrwsel	DESCRIPTION
0	CD-R mode
1	CD-RW mode

Table 24 Control bits for urefsel

urefsel	REFERENCE OUTPUT VOLTAGE
0	2.9 V
1	3.5 V

Table 25 Read byte

POR	DESCRIPTION
0	I ² C-bus bit state differs from power-on reset state
1	I ² C-bus bit state equals power-on reset state; note 1

Note

1. At power-on, an internal power-on reset signal is generated which resets the I²C-bus data bits to a pre-defined state. When the internal data bits are found to be in a POR state (due to an actual power-on reset but also when set via the I²C-bus) bit POR signals logic 1. Using the POR bit to detect occurrence of a power-on reset requires bit PORR to be set to logic 1 after power-up. Setting bit PORR forces the POR bit to logic 0 independent of other I²C-bus bit settings.

Pre-amplifiers for CD-RW systems

TZA1020; TZA1020A

8.2 Characteristics of the I²C-bus

SYMBOL	PARAMETER	FAST-MODE I ² C-BUS		UNIT
		MIN.	MAX.	
f _{SCL}	SCL clock frequency	0	400	kHz
t _{BUF}	bus free time between a STOP and START condition	1.3	–	μs
t _{HD;STA}	hold time (repeated) START condition; after this period, the first clock pulses are generated	0.6	–	μs
t _{LOW}	LOW period of the SCL clock	1.3	–	μs
t _{HIGH}	HIGH period of the SCL clock	0.6	–	μs
t _{SU;STA}	set-up time for a repeated START condition	0.6	–	μs
t _{HD;DAT}	data hold time	0	0.9	μs
t _{SU;DAT}	data set-up time	100	–	ns
t _r	rise time of both SDA and SCL signals	20 + 0.1C _b ⁽¹⁾	300	ns
t _f	fall time of both SDA and SCL signals	20 + 0.1C _b ⁽¹⁾	300	ns
t _{SU;STO}	set-up time for STOP condition	0.6	–	μs
C _b	capacitive load for each bus line; note 1	–	400	pF

Note

1. C_b = total capacitance of one bus line in pF.

For more information on "The I²C-bus and how to use it" see home page <http://www.semiconductors.philips.com>.

Pre-amplifiers for CD-RW systems

TZA1020; TZA1020A

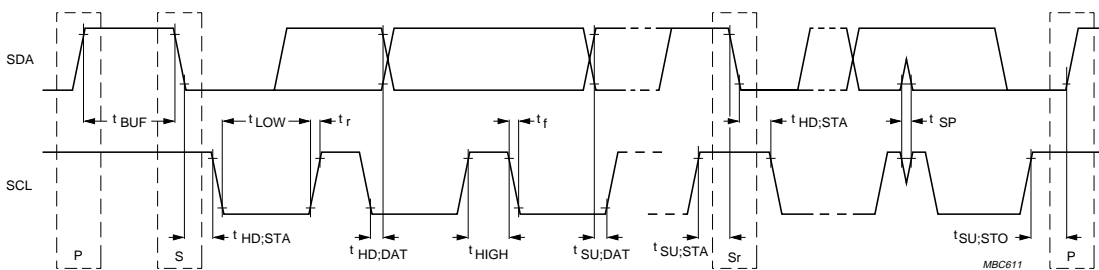

Fig.4 Definition of timing on the I²C-bus.

Pre-amplifiers for CD-RW systems

TZA1020; TZA1020A

Table 26 Scale factors controlled by the I²C-bus interface

SCALE FACTOR	CONTROL SIGNAL	BINARY VALUE CONTROL SIGNAL	VALUE SCALE FACTOR
RE _{scale}	rengain	0	1
		1	1.3
TL _{scale}	tlngain1 and tlngain0	00	1.5
		01	3.0
		10	4.5
		11	6.0
MIR _{scale}	cdrwsel	0	0.05
		1	0.2

Table 27 Currents controlled by the I²C-bus interface; note 1

NORMALIZER CURRENTS	CONTROL SIGNAL	BINARY VALUE CONTROL SIGNAL	VALUE CURRENT (μA)
I _{negain}	negain4 to negain0	00000	3.125
		:	:
		01111	50
		:	:
I _{sumref}	sumref4 to sumref0	11111	100
		:	:
		00000	0.47
		:	:
I _{sdfine}	sdfine7 to sdfine0	01111	7.5
		:	:
		11111	15
		:	:
I _{sdfine}	sdfine7 to sdfine0	0000000	0.12
		:	:
		0111111	15
		:	:
I _{ref}	-	1111111	30
		-	20

Note

1. The currents are proportional to I_{RREF}. The given current values are valid at I_{RREF} = -900 μA.

Pre-amplifiers for CD-RW systems

TZA1020; TZA1020A

9 LIMITING VALUES

In accordance with the Absolute Maximum Rating System (IEC 134).

SYMBOL	PARAMETER	MIN.	MAX.	UNIT
V_{DD}	positive supply voltage	0	13.2	V
T_{stg}	storage temperature	-65	+150	°C
T_{amb}	ambient temperature	0	70	°C
V_{es}	electrostatic handling voltage:			
	Machine model	-200	+200	V
	Human body model	-1000	+1000	V

10 THERMAL CHARACTERISTICS

SYMBOL	PARAMETER	CONDITIONS	VALUE	UNIT
$R_{th(j-a)}$	thermal resistance from junction to ambient	in free air	60	K/W

11 CHARACTERISTICS

$V_{DD1} = V_{DD2} = 5$ V; $V_{SS1} = V_{SS2} = -5$ V; $T_{amb} = 25$ °C; $ERON = 1$; $AMON = 0$; $I_{RREF} = -900$ μ A; unless otherwise specified.

SYMBOL	PARAMETER	CONDITIONS	MIN.	TYP.	MAX.	UNIT
Supplies						
V_{DD1}	positive supply voltage 1 (pin 28)		4.5	5.0	5.5	V
V_{SS1}	negative supply voltage 1 (pin 30)		-5.5	-5.0	-4.5	V
V_{DD2}	positive supply voltage 2 (pin 16)		4.5	5.0	5.5	V
V_{SS2}	negative supply voltage 2 (pin 18)		-5.5	-5.0	-4.5	V
ΔV_{DD}	difference between V_{DD1} and V_{DD2}		-0.5	-	+0.5	V
ΔV_{SS}	difference between V_{SS1} and V_{SS2}		-0.5	-	+0.5	V
$I_{DD(tot)}$	positive supply current $V_{DD1} + V_{DD2}$	quiescent state	-	12	-	mA
		maximum current	-	26	-	mA
		maximum current at $AMON = 1$	-	49	-	mA
$I_{SS(tot)}$	negative supply current $V_{SS1} + V_{SS2}$	quiescent state	-	16	-	mA
		maximum current	-	25	-	mA
		maximum current at $AMON = 1$	-	33	-	mA

Pre-amplifiers for CD-RW systems

TZA1020; TZA1020A

SYMBOL	PARAMETER	CONDITIONS	MIN.	TYP.	MAX.	UNIT
Reference input current; pin RREF						
$I_{i(RREF)}$	input reference current	note 1	–	–900	–	μA
I_{RREF}	current range		–1200	–	–6500	μA
$V_{i(RREF)}$	input voltage on pin RREF	$I_{RREF} = -900 \mu\text{A}$ referenced to V_{SS}	1.22	1.245	1.26	V
Reference voltage buffer; pin UOUT						
V_{UOUT}	LOW-level output reference voltage	urefsel = 0				
		$I_{UOUT} = -6 \text{ mA}$ $I_{UOUT} = 0 \text{ mA}$	2.63 –	2.77 2.9	2.90 –	V V
	HIGH-level output reference voltage	urefsel = 1				
		$I_{UOUT} = -6 \text{ mA}$ $I_{UOUT} = 0 \text{ mA}$	3.23 –	3.4 3.5	3.57 –	V V
I_{UOUT}	current range		–10	–	0	mA
C_{UOUT}	capacitance on pin UOUT (necessary for stability)	$I_{UOUT} = -6 \text{ mA}$	22	–	–	nF
		$I_{UOUT} = 0 \text{ mA}$	100	–	–	nF
Detector inputs						
INPUT CURRENT RANGE						
$I_{i(Cn)}$	central diode input current for C1 to C4	AMON = 0	1.0	–	75	μA
		AMON = 1	0	–	4000	μA
$I_{i(SA,SB)}$	satellite diode input current for SA1/SA2 and SB1/SB2	AMON = 0	0.6	–	9	μA
		AMON = 1	0	–	520	μA
$I_{i(CAGAIN)}$	input current for set-point laser power		30	–	1800	μA
INPUT VOLTAGE LEVEL						
$V_{i(Cn)}$	central diode input voltage for C1 to C4	AMON = 0	–	0	–	V
		AMON = 1	–	1.4	–	V
$V_{i(SA,SB)}$	satellite diode input voltage for SA1/SA2 and SB1/SB2	AMON = 0	–	1.4	–	V
		AMON = 1	–	1.4	–	V
$V_{i(CAGAIN)}$	input current for set-point laser power		–	0.7	–	V
INPUT RESISTANCE						
$R_{i(Cn)}$	central diode input resistance for C1 to C4	AMON = 0	–	300	–	Ω
		AMON = 1; $I_{i(cd)} = 25 \mu\text{A}$ lexton = 1	–	600	–	Ω
		lexton = 0	–	1000	–	Ω
$R_{i(SA,SB)}$	satellite diode input resistance for SA1/SA2 and SB1/SB2	$I_{i(SA,SB)} = 6.25 \mu\text{A}$ lexton = 1	–	1000	–	Ω
		lexton = 0	–	4000	–	Ω
$R_{i(CAGAIN)}$	input resistance for set-point laser power	$I_{i(CAGAIN)} = 35 \mu\text{A}$	–	700	–	Ω

Pre-amplifiers for CD-RW systems

TZA1020; TZA1020A

SYMBOL	PARAMETER	CONDITIONS	MIN.	TYP.	MAX.	UNIT
Digital control signals						
INPUT VOLTAGE LEVELS; PINS ERON, ASTROBE, AINTON, ALS, SDA, SCL AND AMON						
V_{IL}	LOW-level input voltage	$V_{DD1} = V_{DD2} = 5.0\text{ V}$	-0.3	-	+0.9	V
V_{IH}	HIGH-level input voltage	$V_{DD1} = V_{DD2} = 5.0\text{ V}$	2.3	-	5.3	V
OUTPUT VOLTAGE LEVEL; PIN SDA						
V_{OH}	LOW-level output voltage	$V_{DD1} = 5.0\text{ V}$	4.5	-	5.0	V
V_{OL}	HIGH-level output voltage		0	-	0.5	V
INPUT CURRENT						
I_{LI}	input leakage current					
	pins SDA, SCL, AMON and ALS		-1.5	-	0	μA
	pin ERON		-15	-	0	μA
	pins AINTON and ASTROBE		-100	0	+100	nA
DELAY TIMES						
t_d	delay time					
	pins ASTROBE and AINTON		-	15	-	ns
	pins SDA, SCL, AMON and ALS		-	36	50	ns
	pin ERON		-	2.5	3.5	ns
Normalized servo signals; note 2 and Section 11.1						
GAIN SETTINGS						
G_{fe}	gain focus error signal	ERON = 1	0.22	0.24	0.26	
		ERON = 0	-	0	-	
G_{re}	gain radial error signal	ERON = 1	0.87	0.95	1.03	
		ERON = 0	-	0	-	
G_{tl}	gain track loss signal	ERON = 1	0.87	0.95	1.03	
		ERON = 0	-	0	-	
G_{xd}	gain radial beam landing	ERON = 1	0.87	0.95	1.03	
		ERON = 0	-	0	-	
G_{gr}	gain in grating ratio correction	ERON = 1	0.94	1	1.06	
G_{mir}	gain in mirror signal	ERON = 1	0.90	1.03	1.15	

Pre-amplifiers for CD-RW systems

TZA1020; TZA1020A

SYMBOL	PARAMETER	CONDITIONS	MIN.	TYP.	MAX.	UNIT
OFFSET CURRENTS						
$I_{\text{offset(fe)}}$	offset current focus error		-550	0	+550	nA
$I_{\text{offset(re)}}$	offset current radial error	rengain = 0	-1.5	0	+1.5	μA
$I_{\text{offset(tl)}}$	offset current track loss	tlngain(1,0) = 00	-4	0	+4	μA
$I_{\text{offset(xd)}}$	offset radial beam landing		-1.5	0	+1.5	μA
$\Delta I_{\text{offset(re)}}$	variation in offset current radial error	AMON 0 \rightarrow 1	-0.8	0	+0.8	μA
$\Delta I_{\text{offset(tl)}}$	variation in offset current track loss	AMON 0 \rightarrow 1	-1.4	-0.2	+1.2	μA
OUTPUT IMPEDANCE						
$Z_{\text{o(FEN)}}$	output impedance pin FEN		-	40	-	$\text{M}\Omega$
$Z_{\text{o(REN)}}$	output impedance pin REN		-	21	-	$\text{M}\Omega$
$Z_{\text{o(XDN)}}$	output impedance pin XDN		-	21	-	$\text{M}\Omega$
$Z_{\text{o(TLN)}}$	output impedance pin TLN		-	15	-	$\text{M}\Omega$
$Z_{\text{o(MIRN)}}$	output impedance pin MIRN		-	80	-	$\text{M}\Omega$
VOLTAGE RANGE OF OUTPUT SIGNALS						
$V_{\text{o(FEN)}}$	output voltage pin FEN		-4	-	+4	V
$V_{\text{o(REN)}}$	output voltage pin REN		-4	-	+4	V
$V_{\text{o(XDN)}}$	output voltage pin XDN		-4	-	+4	V
$V_{\text{o(l)(TLN)}}$	output voltage pin TLN	tlnlm(1,0) = 00; note 3	-4	-	+3	V
		tlnlm(1,0) = X1; note 3	-1	-	+1	V
		tlnlm(1,0) = 10; note 3	-2	-	+2	V
$V_{\text{o(l)(MIRN)}}$	output voltage linear range pin MIRN; TZA1020	note 4	0.2	-	1.0	V
$V_{\text{o(l)(MIRN)}}$	output voltage linear range pin MIRN; TZA1020A	note 4	0.2	-	4.0	V
BANDWIDTH						
$B_{-3\text{dB}}$	-3 dB bandwidth		48	60	72	kHz
$\Delta B_{-3\text{dB}}$	relative variation of $B_{-3\text{dB}}$ over total input current range		-	-	4	%
Fast track count; see Table 28 and notes 5 and 6						
GAIN SETTINGS						
$Z_{\text{tr(FTC)}}$	transimpedance of fast track circuit	cdrwsel = 0	4	5	6	$\text{k}\Omega$
		cdrwsel = 1	16	20	24	$\text{k}\Omega$
		AMON = 1	-	0	-	$\text{k}\Omega$
G_{gr}	gain in grating ratio correction		0.94	1.00	1.06	
$\Delta V_{\text{RE-NOM(p-p)}}$	nominal signal swing (peak-to-peak value)		-	1	-	V

Pre-amplifiers for CD-RW systems

TZA1020; TZA1020A

SYMBOL	PARAMETER	CONDITIONS	MIN.	TYP.	MAX.	UNIT
$TS_{Ztr(FTC)}$	temperature sensitivity for transimpedance of fast track circuit		–	0.2	–	%/K
FAST TRACK COUNT SIGNAL VOLTAGE OUTPUT; PIN RE						
$V_{o(RE)}$	output voltage range		–3.5	–	+2.5	V
$V_{offset(RE)}$	output offset voltage	cdrwsel = 0	–40	0	+40	mV
		cdrwsel = 1	–100	+25	+150	mV
$R_{o(RE)}$	output resistance	minimum diode currents	–	125	–	Ω
			–	580	–	Ω
$B_{-3dB(RE)}$	bandwidth of RE signal	$C_L = 20$ pF; valid for complete input current range	800	–	–	kHz
Spot position measurements; see Table 29 and note 7						
GAIN SETTINGS						
G_{cd}	gain central diode current combination	AMON = 0	0.45	0.50	0.55	
		AMON = 1	–	0	–	
G_{sd}	gain satellite diode current combinations	AMON = 0	0.9	1.00	1.1	
		AMON = 1	–	0	–	
OFFSET CURRENTS						
$I_{offset(MEAS)}$	offset of MEAS1 current	meassel = 00	–1.6	0	+1.6	μ A
		meassel = 01	–1.6	0	+1.6	μ A
	offset of MEAS2 current	meassel = 00	–1.6	0	+1.6	μ A
		meassel = 01	–1.6	0	+1.6	μ A
Central aperture high frequency output						
$G_{I(CAHF)}$	current gain	cdrwsel = 0; $\Sigma I_{C1} = 180$ μ A	7.5	8.25	9.0	
		cdrwsel = 1; $\Sigma I_{C1} = 50$ μ A	30	35	38	
$I_{offset(CAHF)}$	offset current at zero input current	cdrwsel = 0; $\Sigma I_{C1} = 0$ μ A	–	100		μ A
f_{-3dB}	bandwidth (–3 dB), valid for total current range	$C_i = 12$ pF; note 8	17	–	–	MHz
		$C_i = 5$ pF	19	–	–	MHz
Δt_d	delay variations valid for total current range	f = 0.1 to 12 MHz				
		$C_i = 12$ pF	–	–	0.9	ns
		$C_i = 5$ pF	–	–	1.1	ns

Pre-amplifiers for CD-RW systems

TZA1020; TZA1020A

SYMBOL	PARAMETER	CONDITIONS	MIN.	TYP.	MAX.	UNIT
Laser power calibration signals (beta circuit); see Fig.5 and Table 30						
$I_{p1} = I_{p2} = 10 \text{ TO } 90 \mu\text{A}; 2.1 \times I_{p1}; I_{\text{betascl}} = I_{p1}$						
$V_{\text{ref(beta)}}$	reference voltage for beta detector	AMON = 0	1.1	1.25	1.4	V
		AMON = 1	–	0	–	V
V_{A1}/V_{A2}	ratio between A1 and A2		0.9	1	1.1	–
V_{A1}/V_{CALF}	ratio between CALF and A1		0.8	1	1.2	–
$\Sigma I_{C1} = 100 \mu\text{A}; I_{\text{betascale}} = I_{p1}$						
$B_{-3\text{dB}}$	bandwidth (–3 dB) of CALF and CALFI signal	$C_{\text{CALPF}} = 15 \text{ nF}$ betactrl = 00	–	500	–	Hz
		betactrl = 01	–	1000	–	Hz
		betactrl = 10	–	2000	–	Hz
		betactrl = 11	–	4000	–	Hz
t_{cpeak}	time constant peak detector	$C_{\text{HCA1}} = C_{\text{HCA2}} = 10 \text{ nF}$ betactrl = 00	–	500	–	μs
		betactrl = 01	–	250	–	μs
		betactrl = 10	–	125	–	μs
		betactrl = 11	–	60	–	μs
R_o	output resistance pins A1, A2 and CALF		–	250	–	Ω
V_o	output voltage pins A1, A2 and CALF	$V_{\text{DD1}} = 5.0 \text{ V}$	0	–	4.5	V
Laser power calibration signals (alpha circuit); see note 9 and Tables 31 and 32						
GAIN SETTINGS						
$G_{\text{alpha(}CD\text{-RW)}}$	gain in alpha CD-RW circuit	ERON = 1	0.88	1	1.12	
		ERON = 0	–	0	–	
$G_{\text{CD-R(i)}}$	gain in CD-R input circuit	AINTON = 1	0.53	0.62	0.72	
$G_{\text{CD-R(norm)}}$	gain in CD-R normalizer	ASTROBE = 1	38126	48158	6190	$\mu\text{A/V}$
G_{sub}	subtractor gain	ALS = 1	0.94	0.97	1.0	
		ALS = 0	–	0	–	
$\Delta V_{\text{AINT-ASTROBE}}$	change in voltage measured behind ASTROBE switch	ASTROBE 1 \rightarrow 0	–	130	–	mV
V_{AINT}	voltage range pin AINT		0.5	–	3	V
B_{lpf}	bandwidth of low-pass filter	ERON = 1	48	60	72	kHz
I_{peak}	current to peak detector		0.3	–	2	mA
$I_{\text{L(peak)}}$	leakage current of peak detector	algctr6 = 1; algctr4 = 0	–	100	–	$\mu\text{A}/\mu\text{s}$
t_{cpeak}	time constant peak detector time discrete to time continues	switching AINTON at realistic data speed = N	–	5/N	–	μs

Pre-amplifiers for CD-RW systems

TZA1020; TZA1020A

SYMBOL	PARAMETER	CONDITIONS	MIN.	TYP.	MAX.	UNIT
V_{AZIN}	voltage on AZIN input node	$I_{AZIN} = 100 \mu A$	–	0	–	mV
		$I_{AZIN} = 10 \mu A$	–	–60	–	mV
$V_{O(DALPHA)}$	output voltage pin DALPHA		–3.5	–	+3.5	V
$R_{SW(AINTON)}$	resistance AINTON switch		–	50	–	Ω
Wobble pre-processor; see note 10 and Table 33						
LPF2						
$B_{-3dB(LPF2)}$	bandwidth (–3 dB) of LPF2	$lp sel = 00$	32	40	48	kHz
		$lp sel = 01$	64	80	96	kHz
		$lp sel = 10$	120	150	180	kHz
		$lp sel = 11$	240	300	360	kHz
ΔB_{LPF2}	relative variation B_{LPF2} over input current range	note 10	–	–	6	%
VARIABLE GAIN LOOP						
k_{bal}	sensitivity balance circuit		–	1	–	V^{-1}
G_{bal}	gain balancing circuit	$cdrw sel = 0$	0.758	0.889	0.951	
		$cdrw sel = 1$	3.0	3.5	3.84	
I_l/I_r	input current range of balancing circuit		0.5	–	2	
SR_{loop}	slew rate loop	$ppnctr1 = 0$	–	6200	–	V/s
			–	0	–	V/s
$B_{-3dB(bal)}$	bandwidth variable gain loop	$I_{op} = I_{on} = 0 \mu A$; note 11	800	1000	1250	kHz
		$ppnctr1 = 0$; note 11	–	0	–	kHz
MULTIPLIER LOOP						
$V_{PPN(norm)}$	normalize voltage pin PPN		–	3.14	–	V
R_{ca}	resistance ca	$AMON = 0$	–	8	–	k Ω
		$AMON = 1$	–	–	1	k Ω
$B_{-3dB(HPF)}$	bandwidth (–3 dB) of HPF		40	50	60	kHz
k_{mult}	sensitivity multiplier		–	0.19	–	mA/V ²
$g_{m(V-I)}$	transconductance $V \rightarrow I$	$ V_p - V_{ref(V-I)} < 0.354 V$; note 12	–	340	–	$\mu A/V$
		$ppnctr2 = 0$	–	0	–	$\mu A/V$
$V_{ref(V-I)}$	reference voltage $V \rightarrow I$		3.25	3.5	3.75	V

Pre-amplifiers for CD-RW systems

TZA1020; TZA1020A

SYMBOL	PARAMETER	CONDITIONS	MIN.	TYP.	MAX.	UNIT
OUTPUT STAGE; note 13						
V _{PPN}	voltage range		-3.5	-	+2.5	V
R _(I-V)	I → V conversion resistance		244	320	400	kΩ
V _{offset(PPN)}	offset voltage of PPN signal	I _{ppnscl} = 3.125 μA	-38	+6	+50	mV
		I _{ppnscl} = 100 μA	-1 165	+80	+1 325	mV
		ppnctrl1 = 0 I _{ppnscl} = 3.125 μA I _{ppnscl} = 100 μA	-115 -3800	+6 +80	+130 +4000	mV mV
R _{O(PPN)}	output resistance PPN signal	I _{ppnscl} = 3.125 μA	-	2200	-	Ω
		I _{ppnscl} = 20 μA	-	400	-	Ω
TS _{R(I-V)}	temperature sensitivity of offset voltage of PPN signal		-	0.2	-	%/°C
B _{-3dB(PPN)}	internal signal bandwidth of PPN circuit		-	1	-	MHz

Notes

- In the application, the reference current will be generated by means of a resistor. The given current can be realized by a resistor of 1.3844 kΩ. As these are not available, the actual reference current will be slightly different. This means that all derived signal currents will be scaled in the same way.
- I_{C1} = I_{C2} = I_{C3} = I_{C4} = 10 μA; I_{SA1} = I_{SA2} = I_{SB1} = I_{SB2} = 1.25 μA; I_{ngain} = 50 μA; I_{sdfine} = 20 μA; I_{RREF} = -900 μA; I_{cagain} = 35 μA; ERON = 1.
- The voltage on TLN can be clamped with respect to GND (positive and negative) with one or two diodes. The clamp has an internal resistance of approximately 900 Ω.
- In the TZA1020A, pin MIRN is clamped with respect to GND (positive) by means of one diode.
- I_{C1} = I_{C2} = I_{C3} = I_{C4} = 25 μA; I_{SA1} = I_{SA2} = I_{SB1} = I_{SB2} = 3.125 μA; I_{sdfine} = 20 μA; I_{RREF} = -900 μA.
- $$V_{RE} = -T_{rre} \times \left[(I_{C1} + I_{C4}) - (I_{C2} + I_{C3}) - \frac{4 \times G_{gr} \times (I_{ref} + I_{sdfine})}{I_{ref}} \times ((I_{SA1} + I_{SB1}) - (I_{SA2} + I_{SB2})) \right]$$
- I_{C1} = I_{C2} = I_{C3} = I_{C4} = 25 μA; I_{SA1} = I_{SA2} = I_{SB1} = I_{SB2} = 3.125 μA.
- C_i = total capacitance connected to all input pins C1 to C4 (between pin and ground).
- ΣI_{C1} = 2e-3 · (1 + 0.7 sin(12π · 3e6 · t)) μA; I_{SA1} = I_{SB1} = I_{SA2} = I_{SB2} = 25 μA; I_{MIRN} = 15 μA; I_{alphagain} = 50 μA; I_{sumref} = 15 μA; I_{AZIN} = 100 μA; AMON = 1; alphactrl(2 to 0) = 000; algctr4 = 00; algctr6 = 1; algctr5 = 0; I_{CAGAIN} = 200 μA.
- I_{C1} = I_{C2} = I_{C3} = I_{C4} = 25 μA; I_{ppnscl} = 50 μA; ppnctrl1 = 1, ppnctrl2 = 1.
- Bandwidth = $\frac{S_{floop} \times k_{bal}}{2\pi}$.
- I_{op} and I_{on} are limited to 12 μA ± 3 μA.
- $$V_{PPN} = \left(\frac{L-R}{L+R} \right) \times R_{(I-V)} \times I_{ppnscl}$$

Pre-amplifiers for CD-RW systems

TZA1020; TZA1020A

Table 28 Fast track count; note 1

FTC CURRENTS	CONTROL SIGNAL	BINARY VALUE CONTROL SIGNAL	VALUE CURRENT (μA)
$I_{\text{sd-fine}}$	sdfine7 to sdfine0	0000000	0.12
		:	:
		0111111	15
		:	:
		1111111	30
I_{ref}	–	–	20

Note

- The currents are proportional to I_{RREF} . The given current values are valid at $I_{\text{RREF}} = -900 \mu\text{A}$.

Table 29 Spot position measurements

meassel CODE	I_{MEAS1}	I_{MEAS2}
00 (POR)	$G_{\text{cd}} [(I_{\text{C1}} + I_{\text{C4}}) - (I_{\text{C2}} + I_{\text{C3}})]$	$G_{\text{cd}} [(I_{\text{C1}} + I_{\text{C2}}) - (I_{\text{C3}} + I_{\text{C4}})]$
01	$G_{\text{sd}} (I_{\text{SA1}} - I_{\text{SA2}})$	$G_{\text{sd}} (I_{\text{SB2}} - I_{\text{SB1}})$
10	$G_{\text{sd}} (I_{\text{SA1}} + I_{\text{SB1}})$	$G_{\text{sd}} (I_{\text{SA2}} + I_{\text{SB2}})$
11	$G_{\text{sd}} (I_{\text{SA1}} + I_{\text{SA2}})$	$G_{\text{sd}} (I_{\text{SB1}} + I_{\text{SB2}})$

Table 30 Laser power calibration (beta circuit); note 1

BETA CIRCUIT CURRENTS	CONTROL SIGNAL	BINARY VALUE CONTROL SIGNAL	VALUE CURRENT (μA)
I_{betasc1}	betasc14 to betasc10	00000	3.125
		:	:
		01111	50
		:	:
		11111	100

Note

- The currents are proportional to I_{RREF} . The given current values are valid $I_{\text{RREF}} = -900 \mu\text{A}$.

Pre-amplifiers for CD-RW systems

TZA1020; TZA1020A

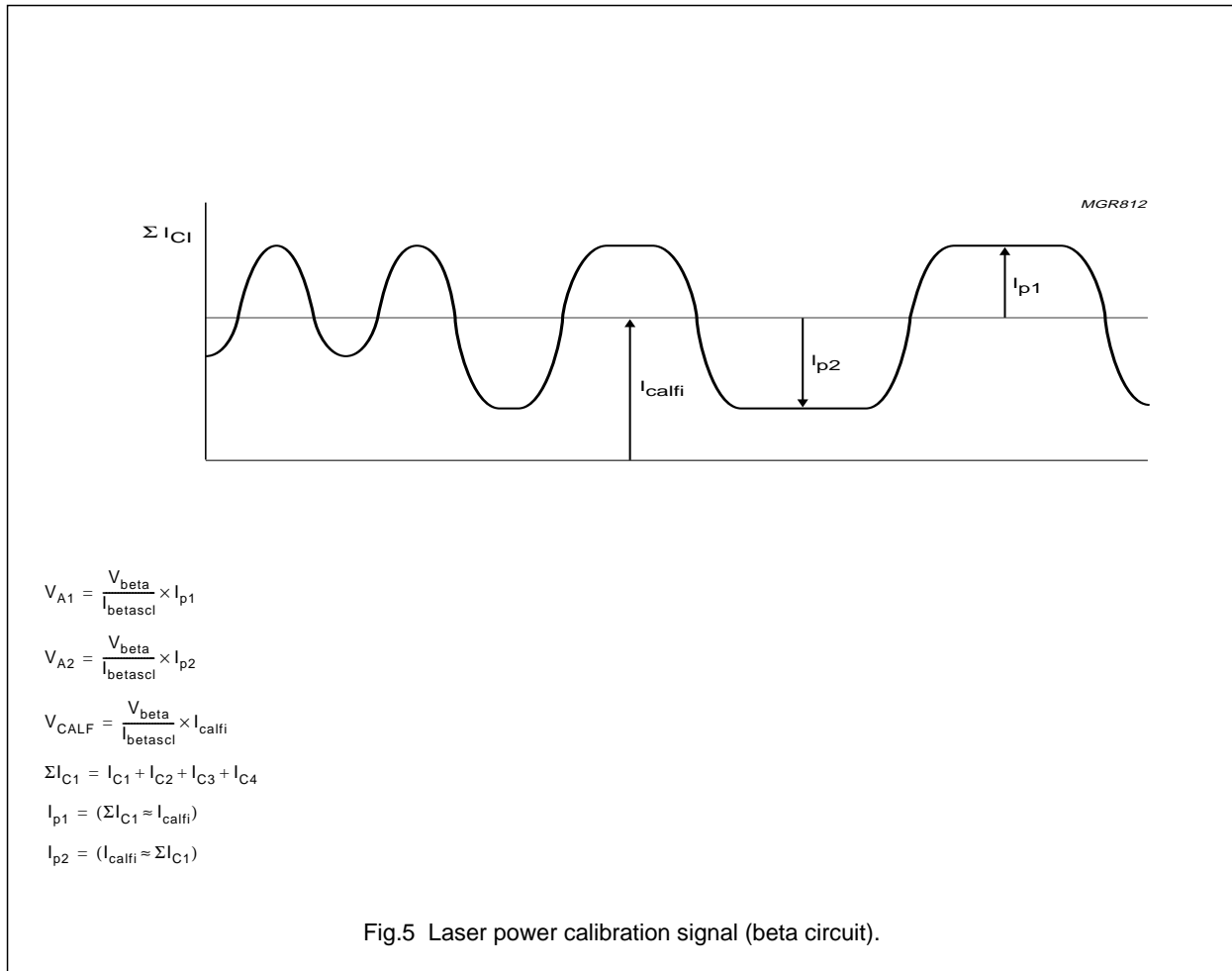

Pre-amplifiers for CD-RW systems

TZA1020; TZA1020A

11.1 Transfer functions for normalized servo signals

$$I_{FEN} = G_{fe} \times \left(\frac{I_{C1} - I_{C4}}{I_{C1} + I_{C4}} + \frac{I_{C3} - I_{C2}}{I_{C3} + I_{C2}} \right) \times I_{negdoc}$$

$$I_{XDN} = G_{xd} \times \left(\frac{(I_{C1} + I_{C4}) - (I_{C2} + I_{C3}) - G_{sat} \times (I_{S1} - I_{S2})}{I_{C1} + I_{C2} + I_{C3} + I_{C4} + G_{sat} \times (I_{S1} + I_{S2})} \right) \times I_{negdoc}$$

$$I_{REN} = G_{re} \times RE_{scale} \times \left(\frac{(I_{C1} + I_{C4}) - (I_{C2} + I_{C3}) - G_{sat} \times (I_{S1} - I_{S2})}{I_{C1} + I_{C2} + I_{C3} + I_{C4} + G_{sat} \times (I_{S1} + I_{S2})} \right) \times I_{negdoc}$$

$$I_{TLN} = G_{tl} \times TL_{scale} \times \left(\frac{(I_{C1} + I_{C4}) - (I_{C2} + I_{C3}) - G_{sat} \times (I_{S1} - I_{S2})}{I_{C1} + I_{C2} + I_{C3} + I_{C4} + G_{sat} \times (I_{S1} + I_{S2})} \right) \times I_{negdoc}$$

$$I_{MIRN} = -G_{mir} \times MIR_{scale} \times \left(\frac{(I_{C1} + I_{C4}) - (I_{C2} + I_{C3}) - G_{sat} \times (I_{S1} - I_{S2})}{I_{CAGAIN}} \right) \times I_{neggain}$$

$$I_{negdoc} = I_{neggain} \times \left(\frac{I_{C1} + I_{C2} + I_{C3} + I_{C4}}{I_{sumref}} \right) \quad \text{at } I_{C1} + I_{C2} + I_{C3} + I_{C4} < 0.9 I_{sumref}$$

$$I_{negdoc} = I_{neggain} \times \left(\frac{I_{C1} + I_{C2} + I_{C3} + I_{C4}}{I_{sumref}} \right) \quad \text{at } I_{C1} + I_{C2} + I_{C3} + I_{C4} > 1.1 I_{sumref}$$

$$I_{negdoc} = I_{neggain} \times \left(\frac{I_{C1} + I_{C2} + I_{C3} + I_{C4}}{I_{sumref}} \right) \quad \text{at } I_{C1} + I_{C2} + I_{C3} + I_{C4} > 1.1 I_{sumref}$$

$$I_{S1} = I_{SA1} + I_{SB1}, I_{S2} = I_{SA2} + I_{SB2}$$

$$G_{sat} = \frac{4 \times G_{gr} \times (I_{ref} + I_{sdfine})}{I_{ref}}$$

Pre-amplifiers for CD-RW systems

TZA1020; TZA1020A

11.2 Laser power control signals (alpha circuit)

The alpha circuit can be split into an alpha circuit for CD-RW, an alpha circuit for CD-R and a subtractor with additional gain switching. The alpha circuit is active only if AMON = 1.

Table 31 Alpha scale factors

SCALE FACTOR	CONTROL SIGNAL	BINARY VALUE CONTROL SIGNAL	VALUE SCALE FACTOR
gain input current	alphactrl2 to alphactrl0	000	0.50
		001	0.33
		010	0.25
		011	0.20
		100	0.17
		101	0.14
		110	0.12
		111	0.11
current gain output	algctrl4 and Algctrl6	00	0
		01	1
		10	3
		11	4
subtractor gain	algctrl1 and algctrl0	00	0.25
		01	0.5
		10	0.75
		11	1.0

Table 32 Alpha currents; note 1

ALPHA CIRCUIT CURRENTS	CONTROL SIGNAL	BINARY VALUE CONTROL SIGNAL	VALUE CURRENT (μA)
$I_{\text{alphagain}}$	alphagain4 to alphagain0	00000	3.125
		01111	50
		11111	100
I_{ref}	—	—	20

Note

- The currents and gain factor are proportional to I_{RREF} . The given current values are valid at $I_{\text{RREF}} = -900 \mu\text{A}$.

Pre-amplifiers for CD-RW systems

TZA1020; TZA1020A

11.3 Wobble pre-processor**Table 33** Wobble currents; note 1

WOBBLE CURRENTS	CONTROL SIGNAL	BINARY VALUE CONTROL SIGNAL	VALUE CURRENT (μA)
I_{ppnsc1}	ppnsc14 to ppsc10	00000	3.125
		:	:
		01111	50
		:	:
		11111	100

Note

1. The currents are proportional to I_{RREF} . The given current values are valid at $I_{\text{RREF}} = -900 \mu\text{A}$.

Pre-amplifiers for CD-RW systems

TZA1020; TZA1020A

12 APPLICATION AND TEST INFORMATION

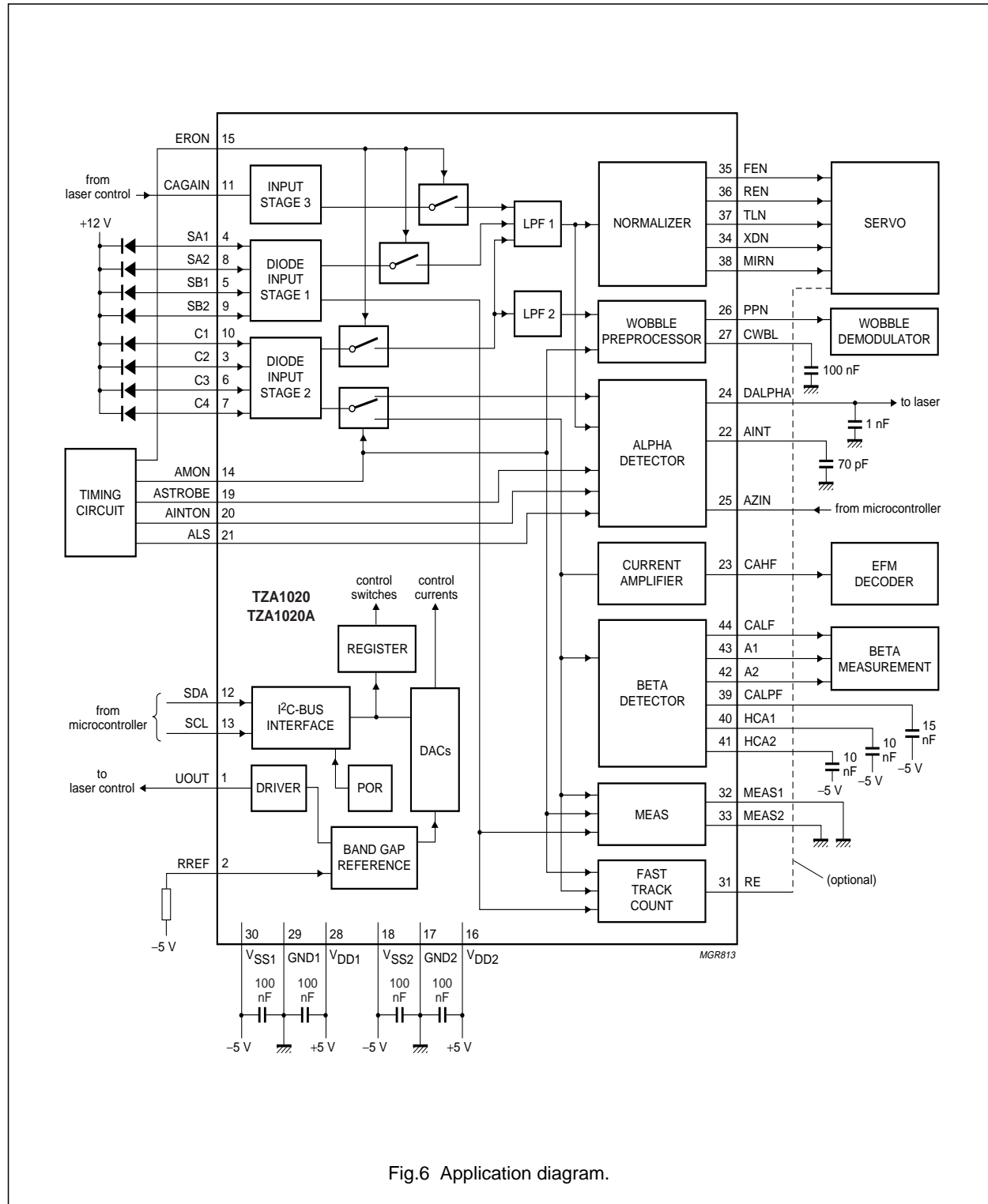

Fig.6 Application diagram.

Pre-amplifiers for CD-RW systems

TZA1020; TZA1020A

13 PACKAGE OUTLINE

QFP44: plastic quad flat package; 44 leads (lead length 1.3 mm); body 10 x 10 x 1.75 mm

SOT307-2

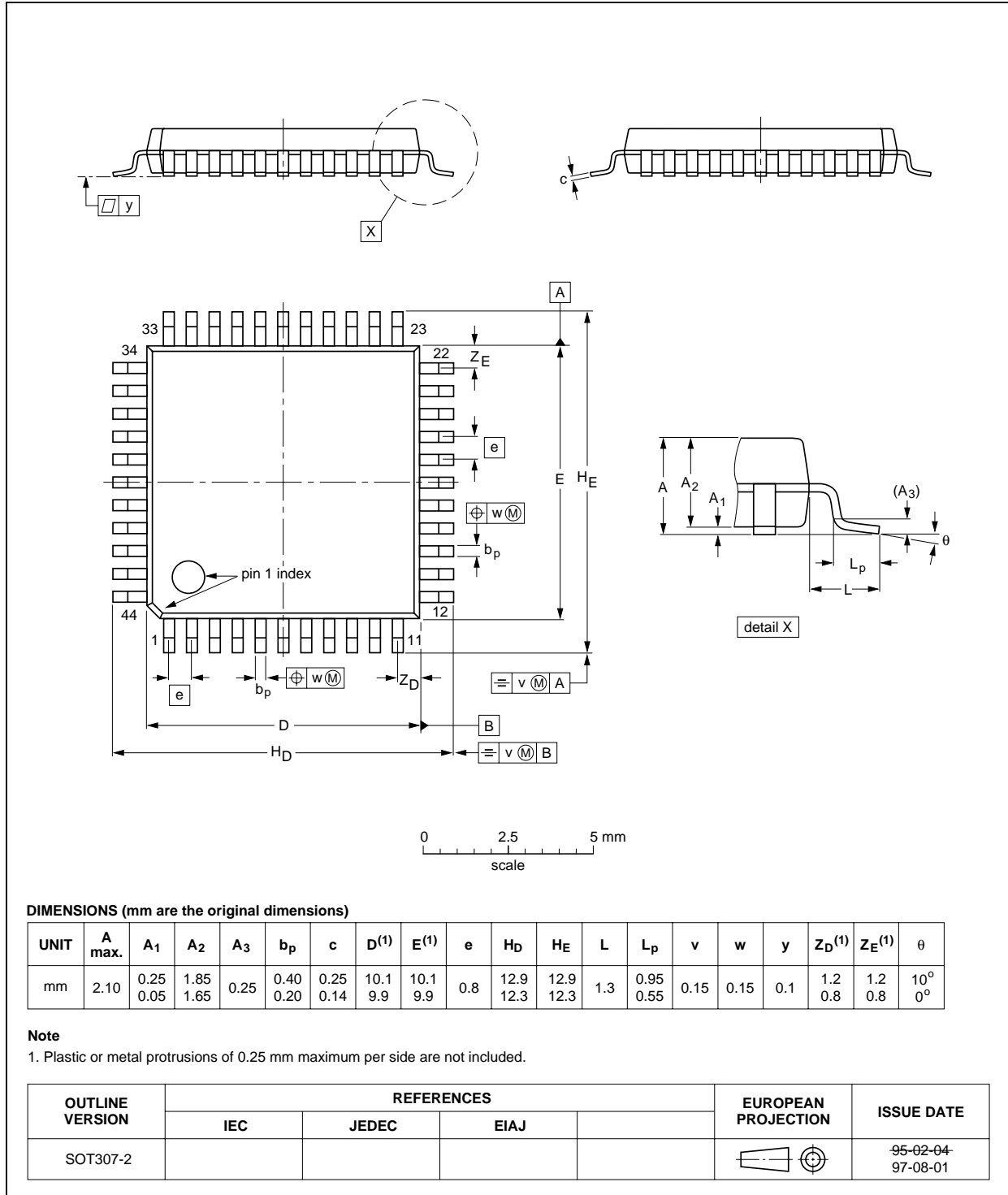

Pre-amplifiers for CD-RW systems

TZA1020; TZA1020A

14 SOLDERING

14.1 Introduction to soldering surface mount packages

This text gives a very brief insight to a complex technology. A more in-depth account of soldering ICs can be found in our *"Data Handbook IC26; Integrated Circuit Packages"* (document order number 9398 652 90011).

There is no soldering method that is ideal for all surface mount IC packages. Wave soldering is not always suitable for surface mount ICs, or for printed-circuit boards with high population densities. In these situations reflow soldering is often used.

14.2 Reflow soldering

Reflow soldering requires solder paste (a suspension of fine solder particles, flux and binding agent) to be applied to the printed-circuit board by screen printing, stencilling or pressure-syringe dispensing before package placement.

Several methods exist for reflowing; for example, infrared/convection heating in a conveyor type oven. Throughput times (preheating, soldering and cooling) vary between 100 and 200 seconds depending on heating method.

Typical reflow peak temperatures range from 215 to 250 °C. The top-surface temperature of the packages should preferably be kept below 230 °C.

14.3 Wave soldering

Conventional single wave soldering is not recommended for surface mount devices (SMDs) or printed-circuit boards with a high component density, as solder bridging and non-wetting can present major problems.

To overcome these problems the double-wave soldering method was specifically developed.

If wave soldering is used the following conditions must be observed for optimal results:

- Use a double-wave soldering method comprising a turbulent wave with high upward pressure followed by a smooth laminar wave.
- For packages with leads on two sides and a pitch (e):
 - larger than or equal to 1.27 mm, the footprint longitudinal axis is **preferred** to be parallel to the transport direction of the printed-circuit board;
 - smaller than 1.27 mm, the footprint longitudinal axis **must** be parallel to the transport direction of the printed-circuit board.

The footprint must incorporate solder thieves at the downstream end.

- For packages with leads on four sides, the footprint must be placed at a 45° angle to the transport direction of the printed-circuit board. The footprint must incorporate solder thieves downstream and at the side corners.

During placement and before soldering, the package must be fixed with a droplet of adhesive. The adhesive can be applied by screen printing, pin transfer or syringe dispensing. The package can be soldered after the adhesive is cured.

Typical dwell time is 4 seconds at 250 °C.

A mildly-activated flux will eliminate the need for removal of corrosive residues in most applications.

14.4 Manual soldering

Fix the component by first soldering two diagonally-opposite end leads. Use a low voltage (24 V or less) soldering iron applied to the flat part of the lead. Contact time must be limited to 10 seconds at up to 300 °C.

When using a dedicated tool, all other leads can be soldered in one operation within 2 to 5 seconds between 270 and 320 °C.

Pre-amplifiers for CD-RW systems

TZA1020; TZA1020A

14.5 Suitability of surface mount IC packages for wave and reflow soldering methods

PACKAGE	SOLDERING METHOD	
	WAVE	REFLOW ⁽¹⁾
BGA, SQFP	not suitable	suitable
HLQFP, HSQFP, HSOP, HTSSOP, SMS	not suitable ⁽²⁾	suitable
PLCC ⁽³⁾ , SO, SOJ	suitable	suitable
LQFP, QFP, TQFP	not recommended ⁽³⁾⁽⁴⁾	suitable
SSOP, TSSOP, VSO	not recommended ⁽⁵⁾	suitable

Notes

1. All surface mount (SMD) packages are moisture sensitive. Depending upon the moisture content, the maximum temperature (with respect to time) and body size of the package, there is a risk that internal or external package cracks may occur due to vaporization of the moisture in them (the so called popcorn effect). For details, refer to the Drypack information in the *"Data Handbook IC26; Integrated Circuit Packages; Section: Packing Methods"*.
2. These packages are not suitable for wave soldering as a solder joint between the printed-circuit board and heatsink (at bottom version) can not be achieved, and as solder may stick to the heatsink (on top version).
3. If wave soldering is considered, then the package must be placed at a 45° angle to the solder wave direction. The package footprint must incorporate solder thieves downstream and at the side corners.
4. Wave soldering is only suitable for LQFP, TQFP and QFP packages with a pitch (e) equal to or larger than 0.8 mm; it is definitely not suitable for packages with a pitch (e) equal to or smaller than 0.65 mm.
5. Wave soldering is only suitable for SSOP and TSSOP packages with a pitch (e) equal to or larger than 0.65 mm; it is definitely not suitable for packages with a pitch (e) equal to or smaller than 0.5 mm.

Pre-amplifiers for CD-RW systems

TZA1020; TZA1020A

15 DATA SHEET STATUS

DATA SHEET STATUS	PRODUCT STATUS	DEFINITIONS ⁽¹⁾
Objective specification	Development	This data sheet contains the design target or goal specifications for product development. Specification may change in any manner without notice.
Preliminary specification	Qualification	This data sheet contains preliminary data, and supplementary data will be published at a later date. Philips Semiconductors reserves the right to make changes at any time without notice in order to improve design and supply the best possible product.
Product specification	Production	This data sheet contains final specifications. Philips Semiconductors reserves the right to make changes at any time without notice in order to improve design and supply the best possible product.

Note

1. Please consult the most recently issued data sheet before initiating or completing a design.

16 DEFINITIONS

Short-form specification — The data in a short-form specification is extracted from a full data sheet with the same type number and title. For detailed information see the relevant data sheet or data handbook.

Limiting values definition — Limiting values given are in accordance with the Absolute Maximum Rating System (IEC 60134). Stress above one or more of the limiting values may cause permanent damage to the device.

These are stress ratings only and operation of the device at these or at any other conditions above those given in the Characteristics sections of the specification is not implied. Exposure to limiting values for extended periods may affect device reliability.

Application information — Applications that are described herein for any of these products are for illustrative purposes only. Philips Semiconductors make no representation or warranty that such applications will be suitable for the specified use without further testing or modification.

17 DISCLAIMERS

Life support applications — These products are not designed for use in life support appliances, devices, or systems where malfunction of these products can reasonably be expected to result in personal injury. Philips Semiconductors customers using or selling these products for use in such applications do so at their own risk and agree to fully indemnify Philips Semiconductors for any damages resulting from such application.

Right to make changes — Philips Semiconductors reserves the right to make changes, without notice, in the products, including circuits, standard cells, and/or software, described or contained herein in order to improve design and/or performance. Philips Semiconductors assumes no responsibility or liability for the use of any of these products, conveys no licence or title under any patent, copyright, or mask work right to these products, and makes no representations or warranties that these products are free from patent, copyright, or mask work right infringement, unless otherwise specified.

18 PURCHASE OF PHILIPS I²C COMPONENTS

Purchase of Philips I²C components conveys a license under the Philips' I²C patent to use the components in the I²C system provided the system conforms to the I²C specification defined by Philips. This specification can be ordered using the code 9398 393 40011.

Philips Semiconductors – a worldwide company

Argentina: see South America

Australia: 3 Figtree Drive, HOMEBUSH, NSW 2140,
Tel. +61 2 9704 8141, Fax. +61 2 9704 8139

Austria: Computerstr. 6, A-1101 WIEN, P.O. Box 213,
Tel. +43 1 60 101 1248, Fax. +43 1 60 101 1210

Belarus: Hotel Minsk Business Center, Bld. 3, r. 1211, Volodarski Str. 6,
220050 MINSK, Tel. +375 172 20 0733, Fax. +375 172 20 0773

Belgium: see The Netherlands

Brazil: see South America

Bulgaria: Philips Bulgaria Ltd., Energoproject, 15th floor,
51 James Bourchier Blvd., 1407 SOFIA,
Tel. +359 2 68 9211, Fax. +359 2 68 9102

Canada: PHILIPS SEMICONDUCTORS/COMPONENTS,
Tel. +1 800 234 7381, Fax. +1 800 943 0087

China/Hong Kong: 501 Hong Kong Industrial Technology Centre,
72 Tat Chee Avenue, Kowloon Tong, HONG KONG,
Tel. +852 2319 7888, Fax. +852 2319 7700

Colombia: see South America

Czech Republic: see Austria

Denmark: Sydhavnsgade 23, 1780 COPENHAGEN V,
Tel. +45 33 29 3333, Fax. +45 33 29 3905

Finland: Sinikalliontie 3, FIN-02630 ESPOO,
Tel. +358 9 615 800, Fax. +358 9 6158 0920

France: 51 Rue Carnot, BP317, 92156 SURESNES Cedex,
Tel. +33 1 4099 6161, Fax. +33 1 4099 6427

Germany: Hammerbrookstraße 69, D-20097 HAMBURG,
Tel. +49 40 2353 60, Fax. +49 40 2353 6300

Hungary: see Austria

India: Philips INDIA Ltd, Band Box Building, 2nd floor,
254-D, Dr. Annie Besant Road, Worli, MUMBAI 400 025,
Tel. +91 22 493 8541, Fax. +91 22 493 0966

Indonesia: PT Philips Development Corporation, Semiconductors Division,
Gedung Philips, Jl. Buncit Raya Kav.99-100, JAKARTA 12510,
Tel. +62 21 794 0040 ext. 2501, Fax. +62 21 794 0080

Ireland: Newstead, Clonskeagh, DUBLIN 14,
Tel. +353 1 7640 000, Fax. +353 1 7640 200

Israel: RAPAC Electronics, 7 Kehilat Saloniki St, PO Box 18053,
TEL AVIV 61180, Tel. +972 3 645 0444, Fax. +972 3 649 1007

Italy: PHILIPS SEMICONDUCTORS, Via Casati, 23 - 20052 MONZA (MI),
Tel. +39 039 203 6838, Fax +39 039 203 6800

Japan: Philips Bldg 13-37, Kohnan 2-chome, Minato-ku,
TOKYO 108-8507, Tel. +81 3 3740 5130, Fax. +81 3 3740 5057

Korea: Philips House, 260-199 Itaewon-dong, Yongsan-ku, SEOUL,
Tel. +82 2 709 1412, Fax. +82 2 709 1415

Malaysia: No. 76 Jalan Universiti, 46200 PETALING JAYA, SELANGOR,
Tel. +60 3 750 5214, Fax. +60 3 757 4880

Mexico: 5900 Gateway East, Suite 200, EL PASO, TEXAS 79905,
Tel. +9-5 800 234 7381, Fax +9-5 800 943 0087

Middle East: see Italy

Netherlands: Postbus 90050, 5600 PB EINDHOVEN, Bldg. VB,
Tel. +31 40 27 82785, Fax. +31 40 27 88399

New Zealand: 2 Wagener Place, C.P.O. Box 1041, AUCKLAND,
Tel. +64 9 849 4160, Fax. +64 9 849 7811

Norway: Box 1, Manglerud 0612, OSLO,
Tel. +47 22 74 8000, Fax. +47 22 74 8341

Pakistan: see Singapore

Philippines: Philips Semiconductors Philippines Inc.,
106 Valero St. Salcedo Village, P.O. Box 2108 MCC, MAKATI,
Metro MANILA, Tel. +63 2 816 6380, Fax. +63 2 817 3474

Poland: Al.Jerozolimskie 195 B, 02-222 WARSAW,
Tel. +48 22 5710 000, Fax. +48 22 5710 001

Portugal: see Spain

Romania: see Italy

Russia: Philips Russia, Ul. Usatcheva 35A, 119048 MOSCOW,
Tel. +7 095 755 6918, Fax. +7 095 755 6919

Singapore: Lorong 1, Toa Payoh, SINGAPORE 319762,
Tel. +65 350 2538, Fax. +65 251 6500

Slovakia: see Austria

Slovenia: see Italy

South Africa: S.A. PHILIPS Pty Ltd., 195-215 Main Road Martindale,
2092 JOHANNESBURG, P.O. Box 58088 Newville 2114,
Tel. +27 11 471 5401, Fax. +27 11 471 5398

South America: Al. Vicente Pinzon, 173, 6th floor,
04547-130 SÃO PAULO, SP, Brazil,
Tel. +55 11 821 2333, Fax. +55 11 821 2382

Spain: Balmes 22, 08007 BARCELONA,
Tel. +34 93 301 6312, Fax. +34 93 301 4107

Sweden: Kottbygatan 7, Akalla, S-16485 STOCKHOLM,
Tel. +46 8 5985 2000, Fax. +46 8 5985 2745

Switzerland: Allmendstrasse 140, CH-8027 ZÜRICH,
Tel. +41 1 488 2741 Fax. +41 1 488 3263

Taiwan: Philips Semiconductors, 5F, No. 96, Chien Kuo N. Rd., Sec. 1,
TAIPEI, Taiwan Tel. +886 2 2134 2451, Fax. +886 2 2134 2874

Thailand: PHILIPS ELECTRONICS (THAILAND) Ltd.,
60/14 MOO 11, Bangna Trad Road KM. 3, Bagna, BANGKOK 10260,
Tel. +66 2 361 7910, Fax. +66 2 398 3447

Turkey: Yukari Dudullu, Org. San. Blg., 2.Cad. Nr. 28 81260 Umraniye,
ISTANBUL, Tel. +90 216 522 1500, Fax. +90 216 522 1813

Ukraine: PHILIPS UKRAINE, 4 Patrice Lumumba str., Building B, Floor 7,
252042 KIEV, Tel. +380 44 264 2776, Fax. +380 44 268 0461

United Kingdom: Philips Semiconductors Ltd., 276 Bath Road, Hayes,
MIDDLESEX UB3 5BX, Tel. +44 208 730 5000, Fax. +44 208 754 8421

United States: 811 East Arques Avenue, SUNNYVALE, CA 94088-3409,
Tel. +1 800 234 7381, Fax. +1 800 943 0087

Uruguay: see South America

Vietnam: see Singapore

Yugoslavia: PHILIPS, Trg N. Pasicca 5/v, 11000 BEOGRAD,
Tel. +381 11 3341 299, Fax.+381 11 3342 553

For all other countries apply to: Philips Semiconductors,
Marketing Communications, Building BE-p, P.O. Box 218, 5600 MD EINDHOVEN,
The Netherlands, Fax. +31 40 27 24825

Internet: <http://www.semiconductors.philips.com>

© Philips Electronics N.V. 2000

SCA70

All rights are reserved. Reproduction in whole or in part is prohibited without the prior written consent of the copyright owner.

The information presented in this document does not form part of any quotation or contract, is believed to be accurate and reliable and may be changed without notice. No liability will be accepted by the publisher for any consequence of its use. Publication thereof does not convey nor imply any license under patent- or other industrial or intellectual property rights.

Printed in The Netherlands

753503/01/pp36

Date of release: 2000 Oct 30

Document order number: 9397 750 04694

Let's make things better.

Philips
Semiconductors



PHILIPS