

DUAL COMPARATOR

- Be Possible to Operate at the Wide Range Single or Two Supply Voltage.
- Low Supply Current : $I_{CC}=0.8mA(Typ.)$.
- Low Input Offset Voltage : $V_{IO}=2mV(Typ.)$.
- Wide Common Mode Input Voltage : $0V_{DC}$ to $V_{CC}-1.5V_{DC}$.
- Output is Compatible with TTL, DTL, MOS and C-MOS.
- Output is Open Collector and Wired-OR Possible.
- Possible to exchange the position of Pin⑨ for Pin① because of Pin connection being symmetric. (KIA393S only)
- The Pin① and Pin⑨ of Lead frame was each other connected. (KIA393S Only)

PIN CONNECTION (TOP VIEW)

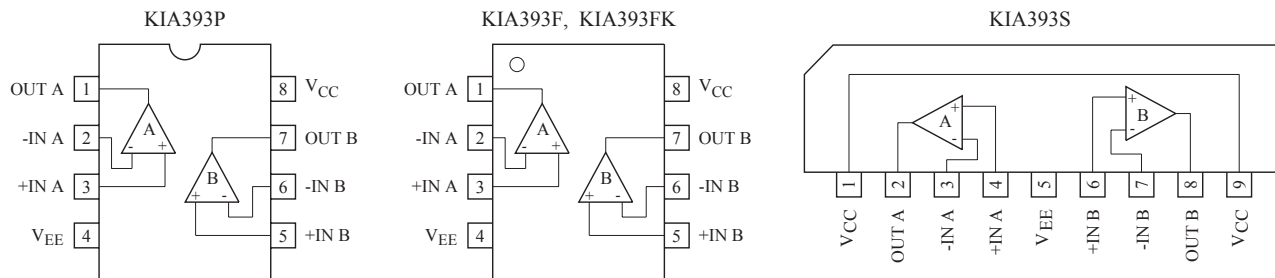

MARKING

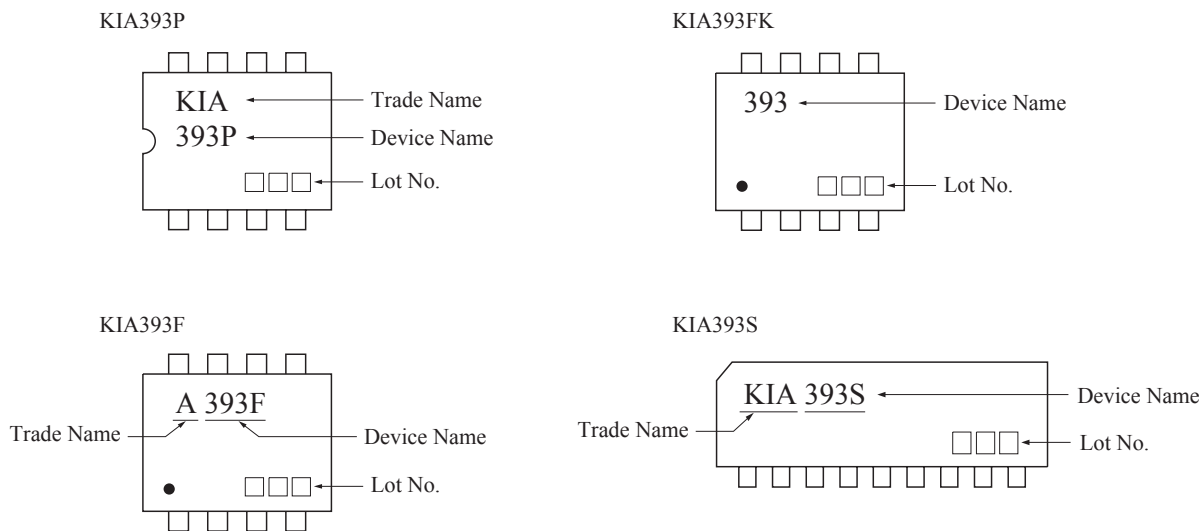

KIA393P/S/F/FK

EQUIVALENT CIRCUIT

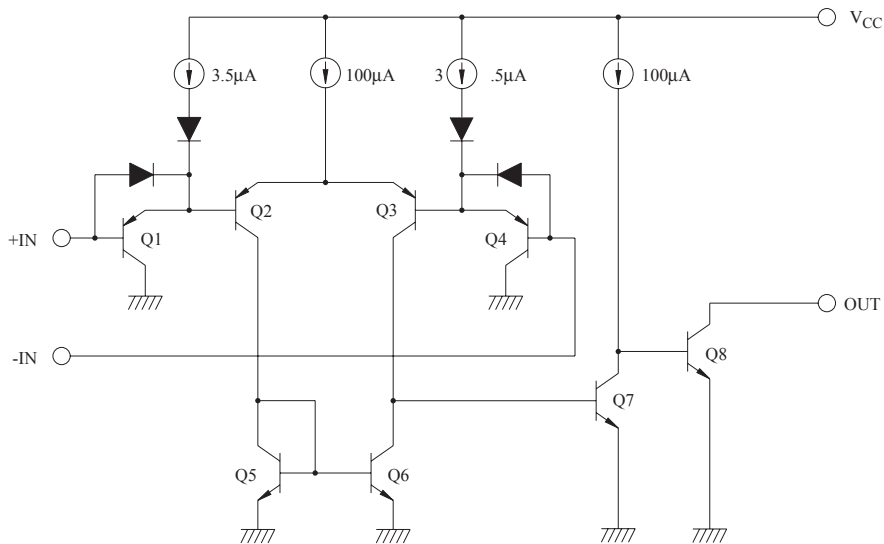

MAXIMUM RATINGS (Ta=25°C)

CHARACTERISTIC		SYMBOL	RATING	UNIT	
Supply Voltage		V_{CC}	$\pm 18, 36$	V	
Differential Input Voltage		DV_{IN}	$\pm 18, 36$	V	
Common Mode Input Voltage		CMV_{IN}	$-0.3 \sim V_{CC}$	V	
Power Dissipation	KIA393P/S	P_D	500	mW	
	KIA393F		240		
	KIA393FK		200		
Operating Temperature		T_{opr}	$-40 \sim 85$	°C	
Storage Temperature		T_{stg}	$-55 \sim 125$	°C	
Pin① to Pin⑨ Maximum Current		KIA393S	I_{max}	1	A

ELECTRICAL CHARACTERISTICS ($V_{CC}=5V$, $V_{EE}=GND$, $T_a=25^\circ C$)

CHARACTERISTIC	SYMBOL	TEST CONDITION	MIN.	TYP.	MAX.	UNIT
Input Offset Voltage	V_{IO}	$V_O=1.4V$	-	2	5	mV
Input Offset Current	I_{IO}	-	-	5	50	nA
Input Bias Current	I_I	-	-	25	250	nA
Common Mode Input Voltage	CMV_{IN}	-	0	-	$V_{CC}-1.5$	V
Voltage Gain	G_V	$R_L=15k\Omega$	-	200	-	V/mV
Supply Current	I_{CC}	No load	-	0.8	2	mA
Sink Current	I_{sink}	+IN=0V, -IN=1V, $V_{OL}=1.5V$	6	16	-	mA
Output Voltage ("L" Level)	V_{OL}	+IN=0V, -IN=1V, $I_{sink}=3mA$	-	0.2	0.4	V
Output Leak Current	I_{LEAK}	+IN=1V, -IN=0V, $V_O=5V$	-	0.1	-	nA
Response Time	t_{rsp}	$R_L=5.1k\Omega$, $C_L=15pF$	-	1.3	-	μs

KIA393P/S/F/FK

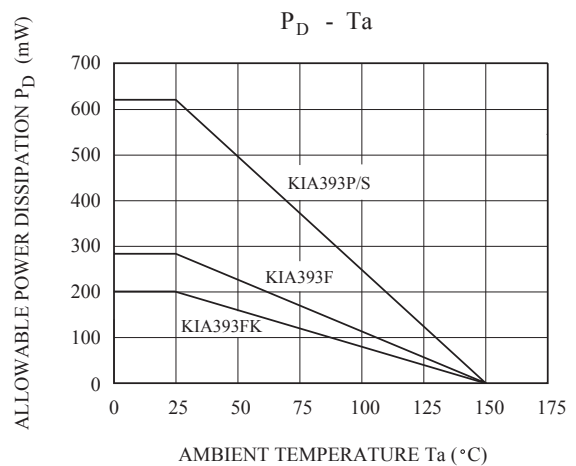
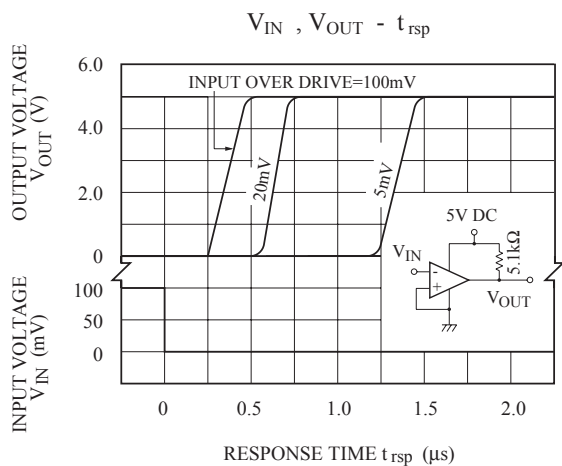
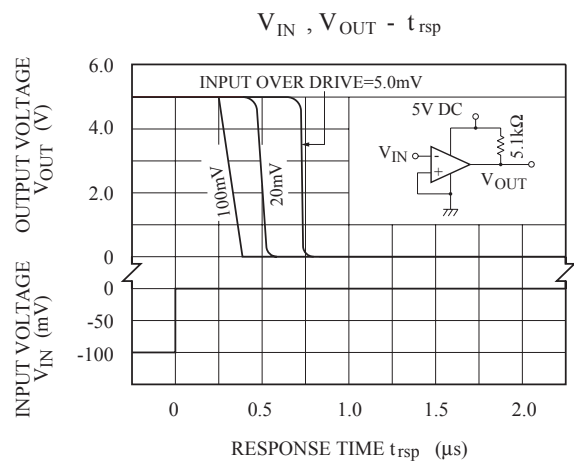
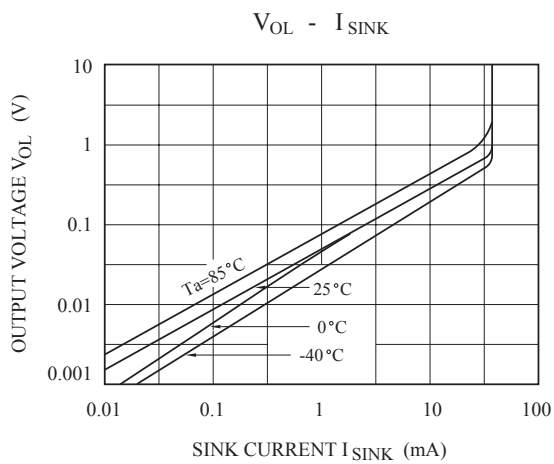
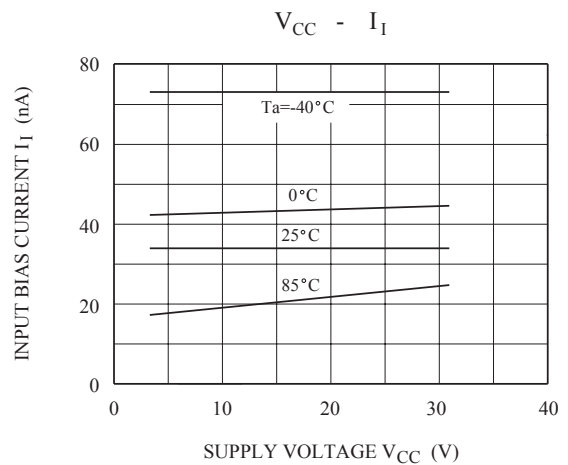
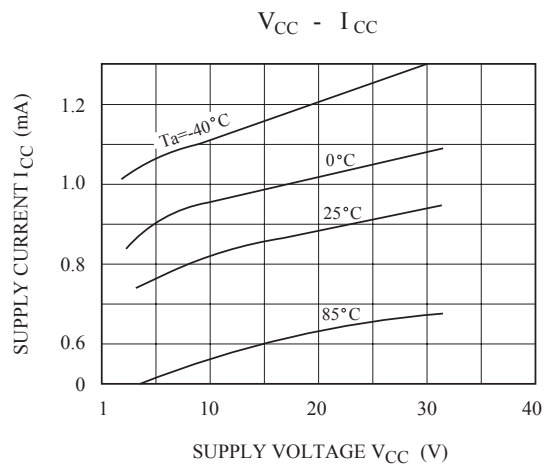

KIA393P/S/F/FK

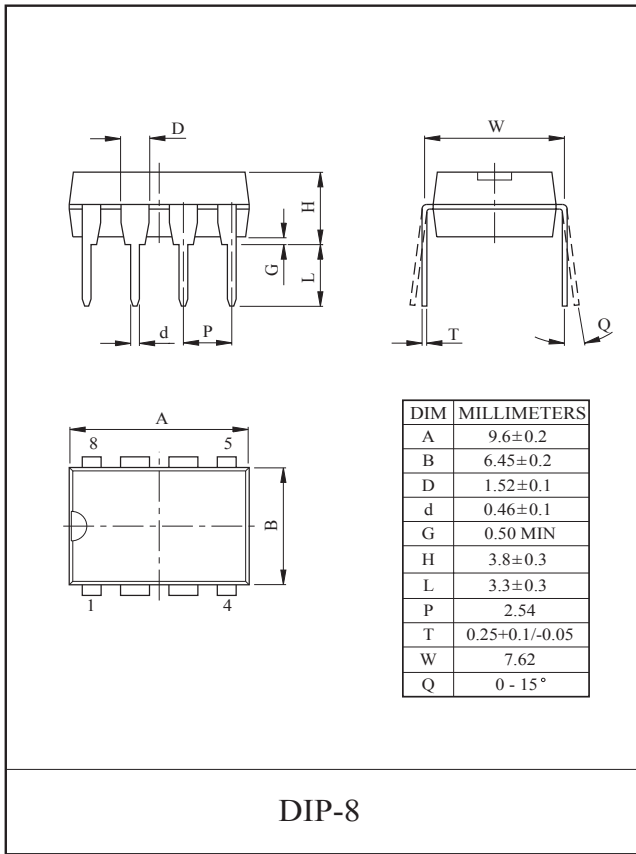

DIP-8

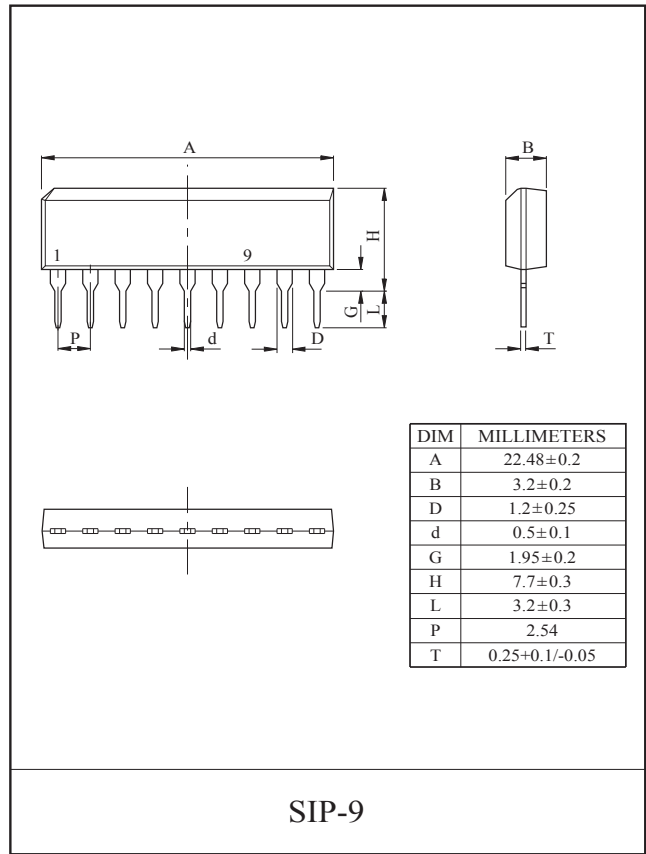

SIP-9

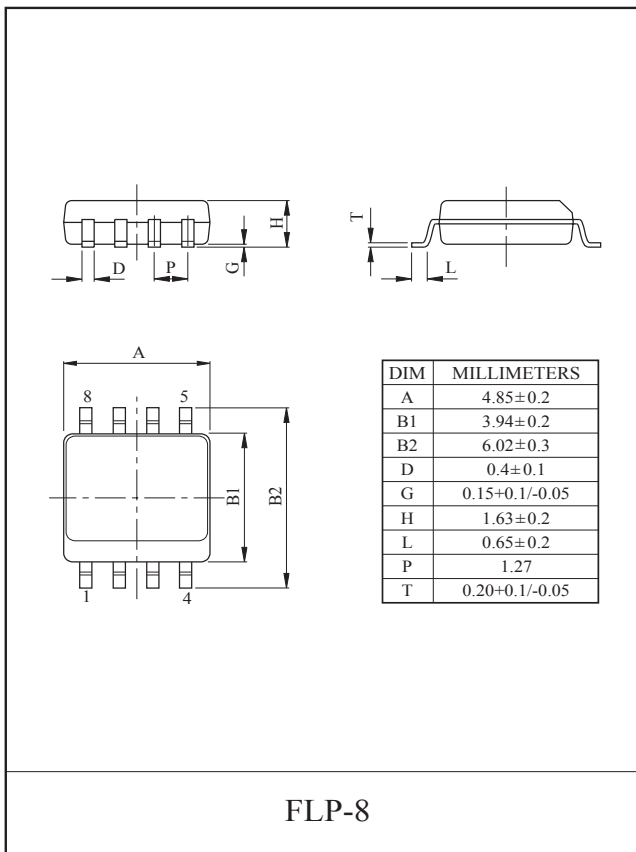

FLP-8

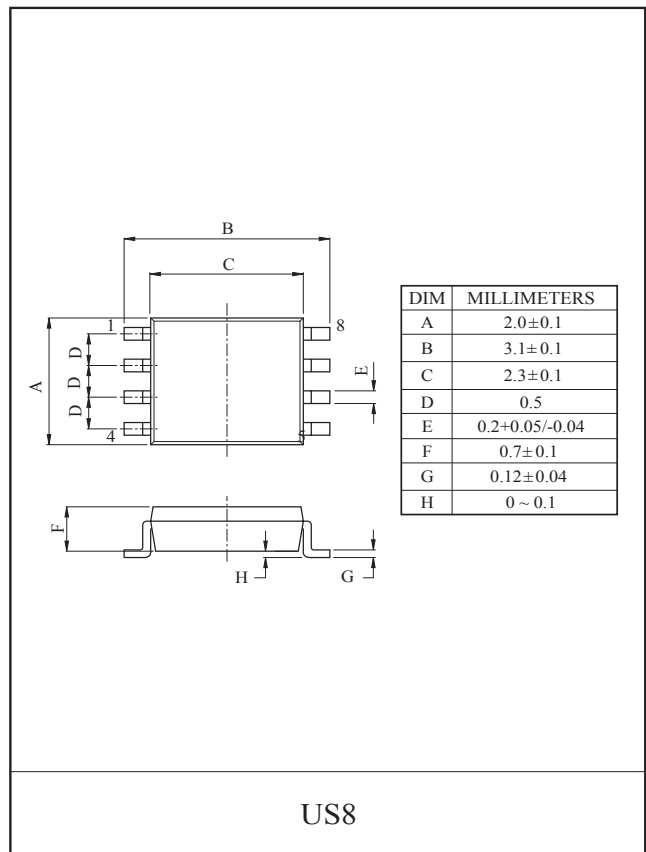

US8