

HIGH PERFORMANCE CURRENT MODE CONTROLLER

The KIA3842P/F is high performance fixed frequency current mode controller. This is specifically designed for Off-Line and DC to DC converter applications offering the designer a cost effective solution with minimal external components. This integrated circuit feature a trimmed oscillator for precise duty cycle control, a temperature compensated reference, high gain error amplifier, current sensing comparator, and a high current totempole output ideally suited for driving a power MOSFET. Also included are protective features consisting of input and reference undervoltage lockouts each with hysteresis, cycle-by-cycle current limiting, programmable output deadtime, and a latch for single pulse metering. These devices are available in 8pin dual-in-line plastic packages as well as the 14pin plastic, surface mount(FLP-14).

The FLP-14 package has separate power and ground pins for the totempole output stage. The KIA3842P/F has UVLO thresholds of 16V(on) and 10V(off), ideally suited for off-line converters.

FEATURES

- Trimmed Oscillator Discharge Current for Precise Duty Cycle Control.
- Current Mode Operation to 500kHz.
- Automatic Feed Forward Compensation.
- Latching PWM for Cycle-By-Cycle Current Limiting.
- Internally Trimmed Reference with Undervoltage Lockout.
- High Current TotemPole Output.
- Undervoltage Lockout with Hysteresis.
- Low Start-up and Operating Current.

MAXIMUM RATINGS (Ta=25 °C)

CHARACTERISTIC	SYMBOL	RATING	UNIT
Total Power Supply and Zener Current	(I _{CC} +I _Z)	30	mA
Output Current, Source or Sink (Note 1)	I _O	1.0	A
Output Energy (Capacitive Load Per Cycle)	W	5.0	μJ
Current Sense and Voltage Feedback inputs	V _{IN}	-0.3 to + 5.5	V
Error Amp Output Sink Current	I _O	10	mA
Power Dissipation	KIA3842P	1.25	W
	KIA3842F	862	mW
Operating Temperature	T _a	0 to + 70	°C
Storage Temperature	T _{stg}	-65 to + 150	°C

Note 1) : Maximum package power dissipation limits must be observed.

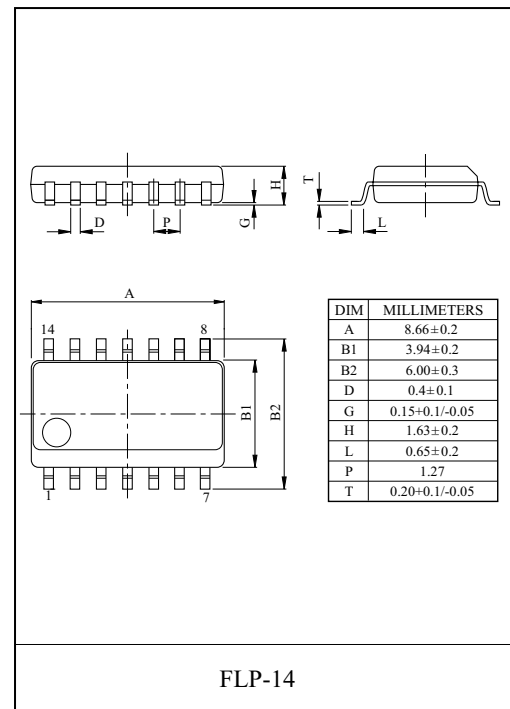
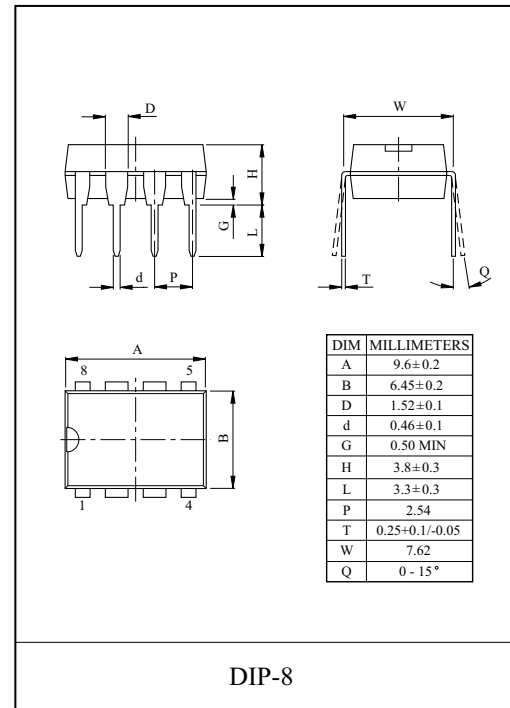

KIA3842P/F

PIN CONNECTIONS (TOP VIEW)

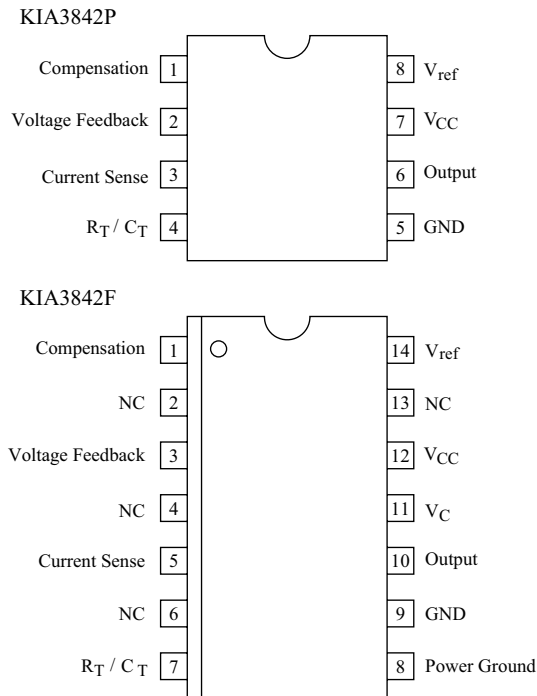

BLOCK DIAGRAM

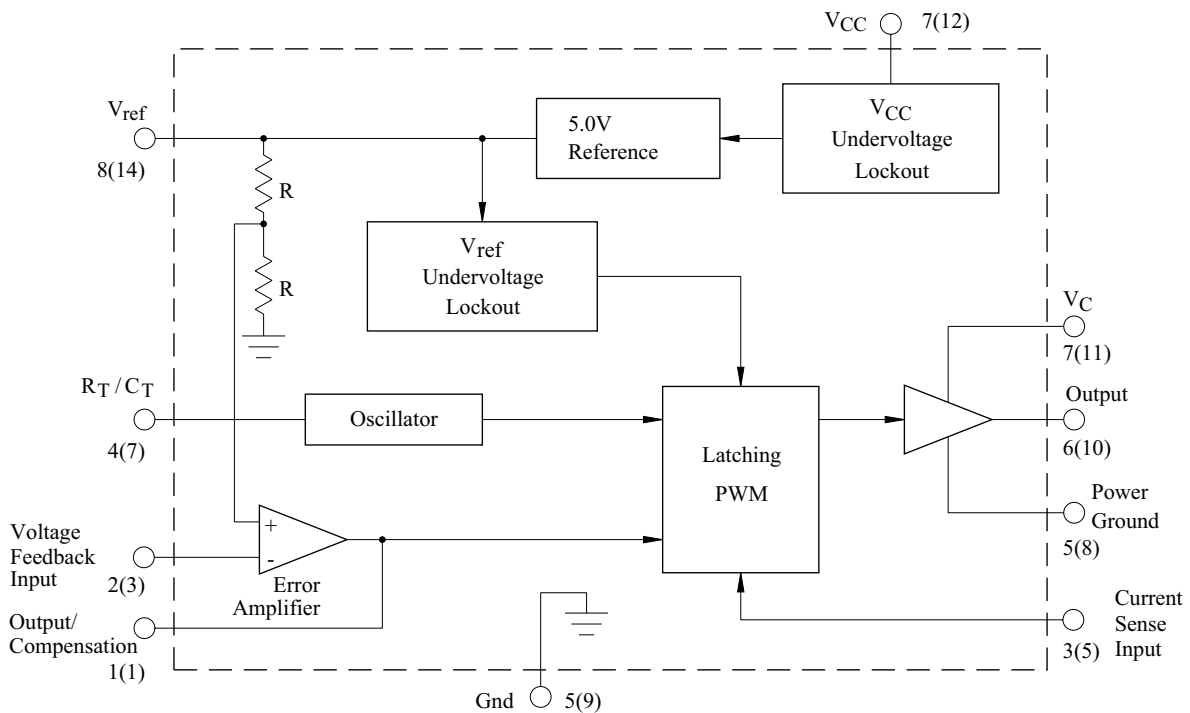

Pin numbers adjacent to terminals are for the DIP-8 package.

Pin numbers in parenthesis are for the FLP-14 package.

KIA3842P/F

ELECTRICAL CHARACTERISTICS (V_{CC}=15V(Note 2), R_T=10kΩ, C_T=3.3nF, Ta=25°C)

REFERENCE SECTION

CHARACTERISTIC	SYMBOL	TEST CONDITION	MIN.	TYP.	MAX.	UNIT
Reference Output Voltage	V _{ref}	I _O =1.0mA, Ta=25°C	4.9	5.0	5.1	V
Line Regulation	Reg _{line}	V _{CC} =12V ~ 25V	-	2.0	20	mV
Load Regulation	Reg _{load}	I _O =1mA ~ 20mA	-	3.0	25	mV
Temperature Stability	T _S	-	-	0.2	-	mV/°C
Total Output Variation over Line, Load, and Temperature	V _{ref}	-	4.82	-	5.18	V
Output Noise Voltage	V _{no}	f=10Hz ~ 10kHz, Ta=25°C	-	50	-	μV
Long Term Stability	S	Ta=125°C, 1000Hrs	-	5.0	-	mV
Output Short Circuit Current	I _{SC}	-	-30	-85	-180	mA

OSCILLATOR SECTION

CHARACTERISTIC	SYMBOL	TEST CONDITION	MIN.	TYP.	MAX.	UNIT
Frequency	f _{osc}	Ta=25°C	47	52	57	kHz
Frequency Change With Voltage	Δf _{osc} /ΔV	V _{CC} =12V ~ 25V	-	0.2	1.0	%
Frequency Change With Temperature	Δf _{osc} /ΔT	Ta=0°C ~ 70°C	-	5.0	-	%
Oscillator Voltage Swing	V _{OSC}	4 PIN Peak to Peak	-	1.6	-	V

ERROR AMPLIFIER SECTION

CHARACTERISTIC	SYMBOL	TEST CONDITION	MIN.	TYP.	MAX.	UNIT
Voltage Feedback Input	V _{FB}	V _O =2.5V	2.42	2.5	2.58	V
Input Bias Current	I _{IB}	V _{FB} =5.0V	-	-0.1	-2.0	μA
Open-Loop Voltage Gain	A _{VOL}	V _O =2.0V ~ 4.0V	65	90	-	dB
Unity Gain Bandwidth	BW	Ta=25°C	0.7	1.0	-	MHz
Power Supply Rejection Ratio	PSRR	V _{CC} =12V ~ 25V	60	70	-	dB
Output Sink Current	I _{sink}	V _O =1.1V, V _{FB} =2.7V	2.0	12	-	mA
Output Source Current	I _{source}	V _O =5.0V, V _{FB} =2.3V	-0.5	-1.0	-	
Vout High	V _{OH}	R _L =15k to GND, V _{FB} =2.3V	5.0	6.2	-	V
Vout Low	V _{OL}	R _L =15k to Ref, V _{FB} =2.7V	-	0.8	1.1	

CURRENT SENSE SECTION

CHARACTERISTIC	SYMBOL	TEST CONDITION	MIN.	TYP.	MAX.	UNIT
Current Sense Input Voltage Gain	A _V	V _{FB} =0, V _{IN} =0 ~ 0.8V $A_V = \frac{\Delta V \text{ output Compensation}}{\Delta V \text{ Current Sense Input}}$	2.85	3.0	3.15	V/V
Maximum Current Sense Input Threshold	V _{th}	V _{FB} =0	0.9	1.0	1.1	V
Power Supply Rejection Ratio	PSRR	V _{CC} =12V ~ 25V, V _{FB} =0	-	70	-	dB
Input Bias Current	I _{IB}	-	-	-2.0	-10	μA
Propagation Delay	t _{PLH(IN/OUT)}	Current Sense Input to Output	-	150	300	ns

KIA3842P/F

OUTPUT SECTION

CHARACTERISTIC	SYMBOL	TEST CONDITION	MIN.	TYP.	MAX.	UNIT
Low State Output Voltage	V_{OL}	$I_{sink}=20mA$	-	0.1	0.4	V
		$I_{sink}=200mA$	-	1.6	2.2	
High State Output Voltage	V_{OH}	$I_{source}=20mA$	13	13.5	-	V
		$I_{source}=200mA$	12	13.4	-	
Rise Time	t_r	$C_L=1.0nF, V_{FB}=0$	-	50	150	ns
Fall Time	t_f	$C_L=1.0nF, V_{FB}=0$	-	50	150	ns

UNDER VOLTAGE LOCKOUT SECTION

CHARACTERISTIC	SYMBOL	TEST CONDITION	MIN.	TYP.	MAX.	UNIT
Start-up Threshold Voltage	V_{TH}		14.5	16	17.5	V
Minimum Operating Voltage	$V_{CC(min)}$	After Turn ON	8.5	10	11.5	V

PWM SECTION

CHARACTERISTIC	SYMBOL	TEST CONDITION	MIN.	TYP.	MAX.	UNIT
Duty Cycle Max.	DC_{max}		94	96	-	%
Duty Cycle Min.	DC_{min}		-	-	0	%

TOTAL DEVICE

CHARACTERISTIC	SYMBOL	TEST CONDITION	MIN.	TYP.	MAX.	UNIT
Power Supply Current	I_{CC}	$V_{CC}=14V$	-	0.5	1.0	mA
		$V_{CC}=15V, \text{ after turn ON}$	-	12	17	
Power Supply Zener Voltage	V_Z	$I_{CC}=25mA$	30	36	-	V

KIA3842P/F

TEST CIRCUIT

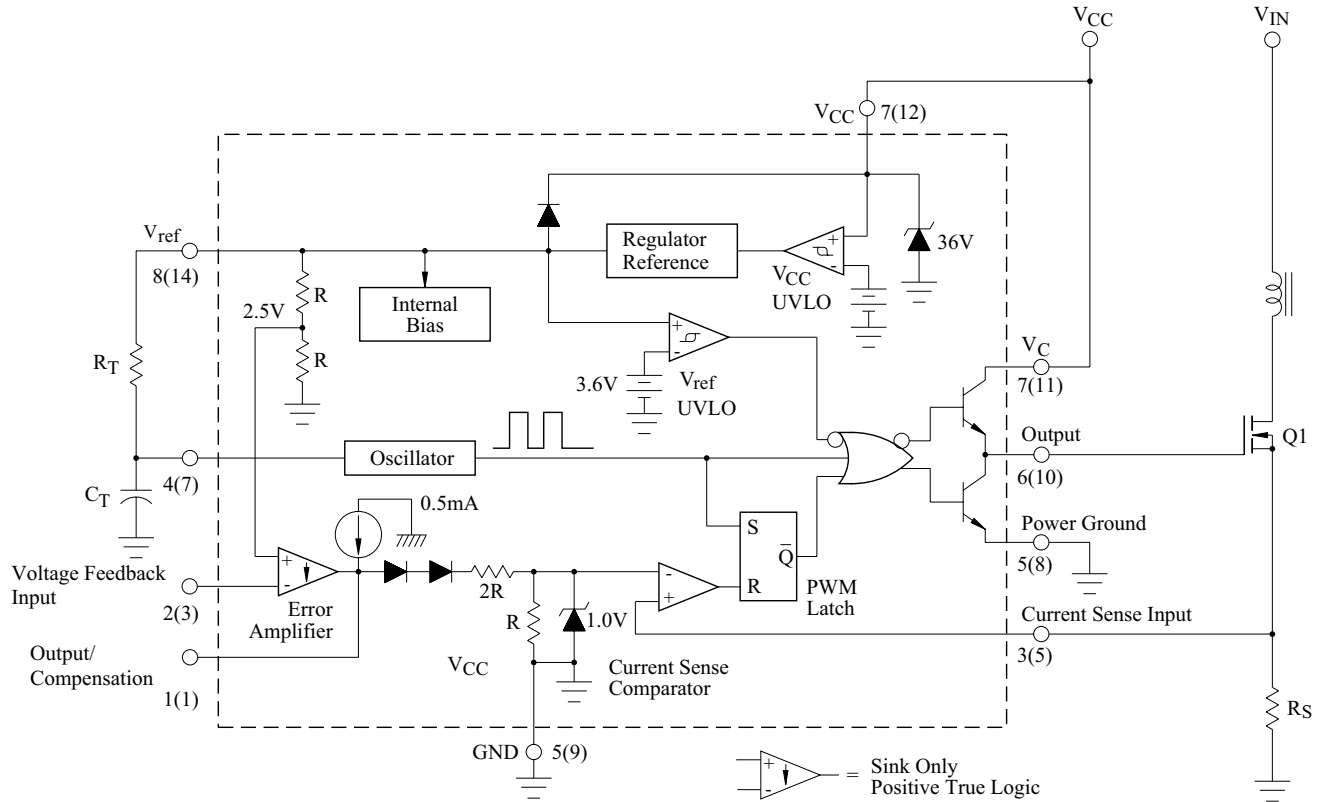

Pin numbers adjacent to terminals are for the DIP-8 package.
Pin numbers in parenthesis are for the FLP-14 package.

KIA3842P/F

PIN FUNCTION DESCRIPTION

PIN NO.		FUNCTION	DESCRIPTION
8-PIN	14-PIN		
1	1	Compensation	This pin is the Error Amplifier output and is made available for loop compensation.
2	3	Voltage Feedback	This is the inverting input of the Error amplifier. It is normally connected to the switching power supply output through a resistor divider.
3	5	Current Sense	A voltage proportional to inductor current is connected to this input. The PWM uses this information to terminate the output switch conduction.
4	7	R_T/C_T	The Oscillator frequency and maximum Output duty Cycle are programmed by connecting resistor R_T to V_{ref} and capacitor C_T to ground. Operation to 500kHz is possible.
5	-	GND	This pin is the combined control circuitry and power ground (8-pin package only).
6	10	Output	This output directly drives the gate of a power MOSFET. Peak currents up to 1.0A are sourced and sunk by this pin.
7	12	V_{CC}	This pin is the positive supply of the control IC.
8	14	V_{ref}	This is the reference output. It provides charging current for capacitor C_T through resistor R_T .
-	8	Power Ground	This pin is a separate power ground return (14pin package only) that is connected back to the power source. It is used to reduce the effects of switching transient noise on the control circuitry.
-	11	V_C	The output high state(V_{OH}) is set by the voltage applied to this pin (14pin package only). With a separate power source connection, It can reduce the effects of switching transient noise on the control circuitry.
-	9	GND	This pin is the control circuitry ground return (14pin package only) and is connected back to the power source ground.
-	2, 4, 6, 13	NC	No connection(14pin package only). These pins are not internally connected.

KIA3842P/F

