

KA3080/KA3080D/KA3080DM

3-Phase BLDC Motor Driver

Features

- 3-Phase, Full-Wave, Linear BLDC Motor Driver With 3 Hall Sensors
- Built-in TSD (Thermal Shutdown) Circuit
- Built-in Torque Ripple Control Circuit
- Built-in Output Current Limiter
- Motor Speed Control
- High Output Current
- Built-in FG Amplifier With Sinusoidal Waveforms
- Built-in Hall Amplifier
- Built-in CW and CCW Circuit

Description

The KA3080 , KA3080D, KA3080DM are a monolithic integrated circuit, and it is suitable for 3-phase capstan motor driver for VCR system.

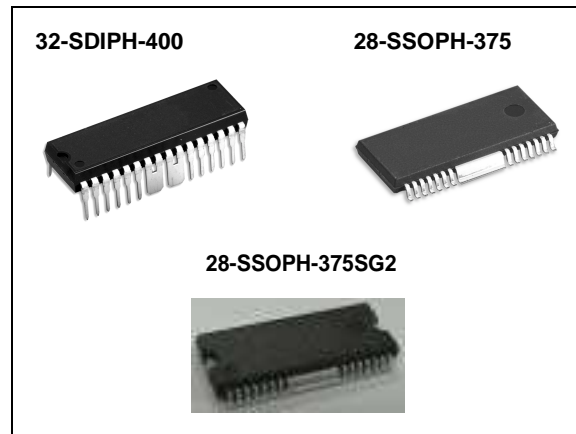

Target Application

- Video Cassette Recorder (VCR) Capstan Motor
- Other 3-Phase BLDC Motor

Ordering Information

Device	Package	Operating Temp.
KA3080C	32-SDIPH-400	-25°C ~ +75°C
KA3080BD	28-SSOPH-375	-25°C ~ +75°C
KA3080BDTF	28-SSOPH-375	-25°C ~ +75°C
KA3080BD3	28-SSOPH-375SG2	-25°C ~ +75°C
KA3080BD3TF	28-SSOPH-375SG2	-25°C ~ +75°C

Pin Assignments (32SDIPH)

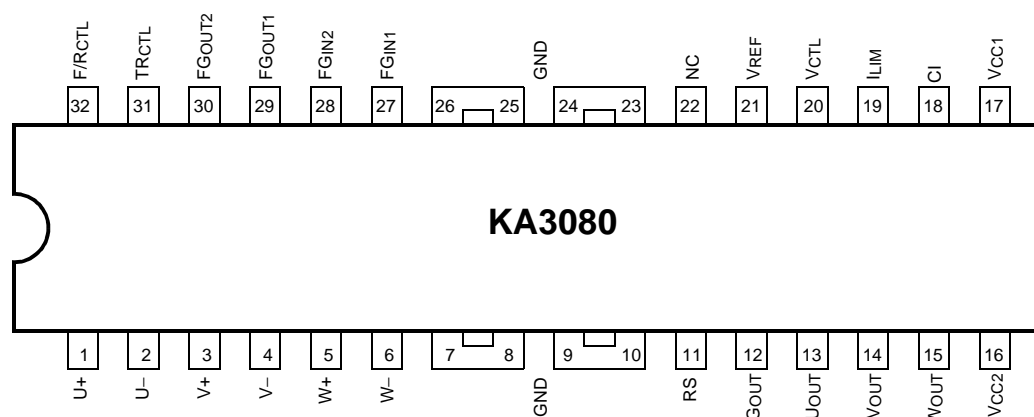

Pin Definitions (32SDIPH)

Pine Number	Pin Name	I/O	Pin Function Description
1	U+	I	U+ Hall Signal Input
2	U-	I	U- Hall Signal Input
3	V+	I	V+ Hall Signal Input
4	V-	I	V- Hall Signal Input
5	W+	I	W+ Hall Signal Input
6	W-	I	W- Hall Signal Input
7	GND	-	Ground (Signal)
8	GND	-	Ground (Signal)
9	GND	-	Ground (Signal)
10	GND	-	Ground (Signal)
11	RS	O	Output Current Detection
12	GOUT	-	Ground (Power)
13	UOUT	O	U Out
14	VOUT	O	V Out
15	WOUT	O	W Out
16	VCC2	-	Supply Voltage (Power)
17	VCC1	-	Supply Voltage(Signal)
18	CI	-	Phase Stabilization
19	ILIM	I	Current Limitation
20	VCTL	I	Voltage Control
21	VREF	I	Voltage Control Reference
22	NC	-	No Connection
23	GND	-	Ground (Signal)
24	GND	-	Ground (Signal)
25	GND	-	Ground (Signal)
26	GND	-	Ground (Signal)

Pin Definitions (32-SDIPH) (Continued)

Pine Number	Pin Name	I/O	Pin Function Description
27	FGIN1	I	FG Amp. Input1
28	FGIN2	I	FG Amp. Input2
29	FGOUT1	O	FG Amp. Output
30	FGOUT2	O	FG Comp. Output
31	TRCTL	I	Troque Ripple Control
32	F/RCTL	I	Forward & Reverse Control

Pin Assignments (28-SSOPH)

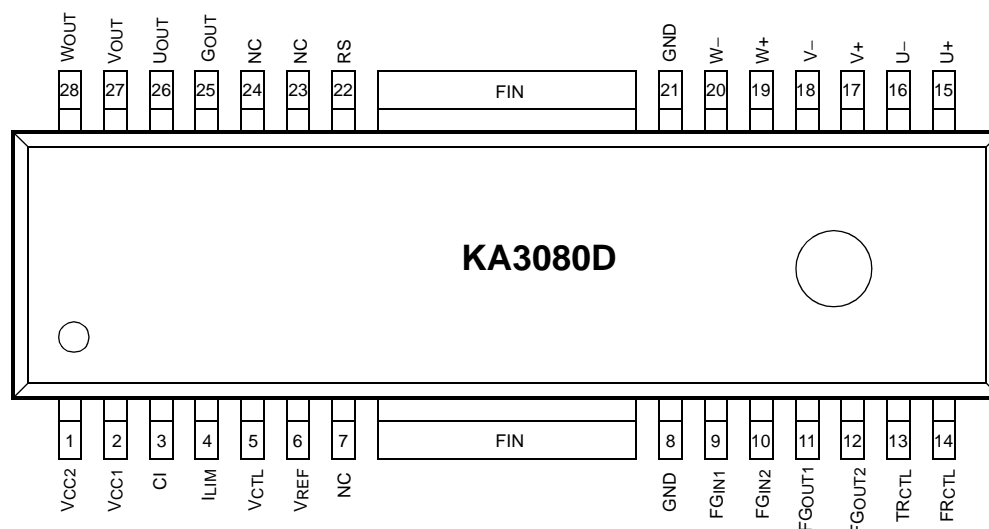

Pin Definitions (28-SSOPH)

Pine Number	Pin Name	I/O	Pin Function Description
1	VCC2	-	Supply Voltage (Power)
2	VCC1	-	Supply Voltage (Signal)
3	CI	-	Phase Stabilization
4	ILIM	I	Current Limitation
5	VCTL	I	Voltage Control
6	VREF	I	Voltage Control Reference
7	NC	-	No Connection
8	GND	-	Ground (Signal)
9	FGIN1	I	FG Amp. Input 1
10	FGIN2	I	FG Amp. Input 2
11	FGOUT1	O	FG Amp. Output
12	FGOUT2	O	FG Comp. Output
13	TRCTL	I	Torque Ripple Control
14	FRCTL	I	Forward & Reverse Control
15	U+	I	U+ Hall Signal Input

Pin Definitions (28-SSOPH) (Continued)

Pin Number	Pin Name	I/O	Pin Function Description
16	U-	I	U- Hall Signal Input
17	V+	I	V+ Hall Signal Input
18	V-	I	V- Hall Signal Input
19	W+	I	W+ Hall Signal Input
20	W-	I	W- Hall Signal Input
21	GND	-	Ground (Signal)
22	RS	O	Output Current Detection
23	NC	-	No Connection
24	NC	-	No Connection
25	GOUT	-	Ground (Power)
26	UOUT	O	U Out
27	VOUT	O	V Out
28	WOUT	O	W Out

Internal Block Diagram (32-SDIPH)

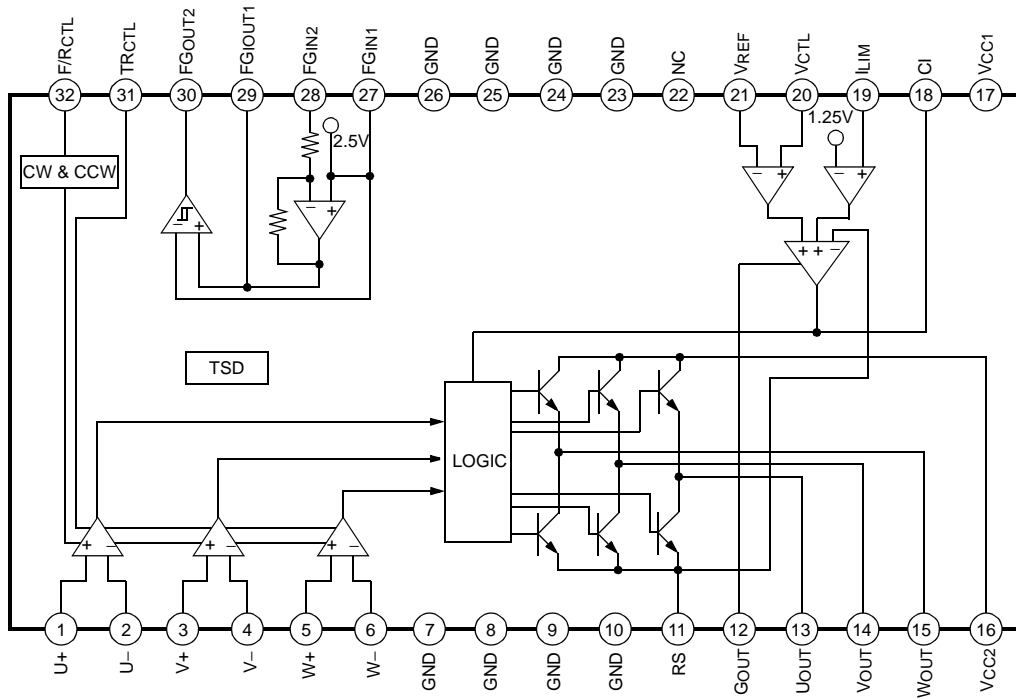

Internal Block Diagram (28-SSOPH)

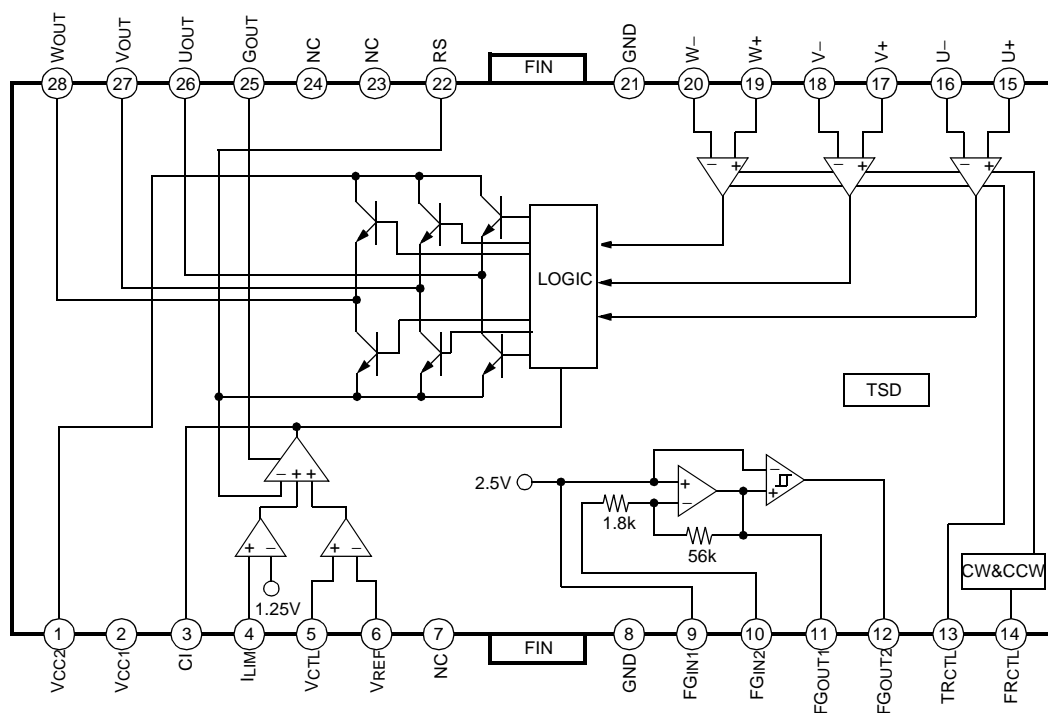

Equivalent Circuits (32-SDIPH: ○, 28-SSOPH: (#))

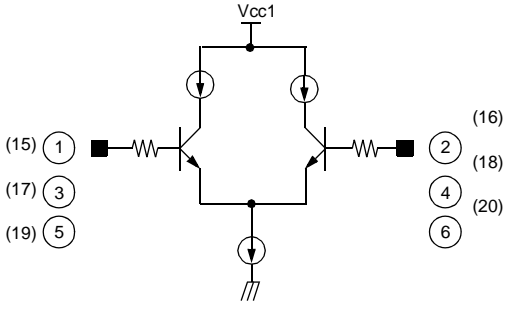
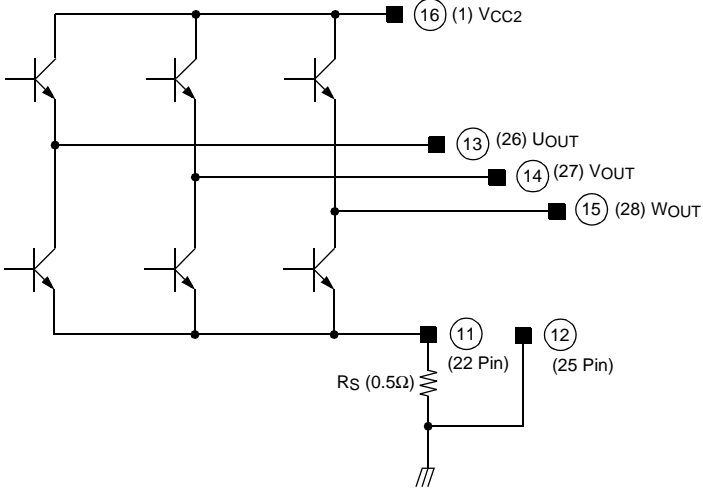
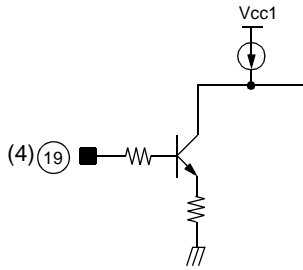
Description	Pin No.	Internal Circuit
Hall Input	32-SDIPH 1, 2, 3 4, 5, 6 28-SSOPH 15, 16, 17 18, 19, 20	
Output & Current Detection	32-SDIPH 13, 14, 15, 11 28-SSOPH 26, 27, 28, 22	
Speed Control (Current limitation)	32-SDIPH 19 28-SSOPH 4	

Equivalent Circuits (32-SDIPH: ○, 28-SSOPH: #) (Continued)

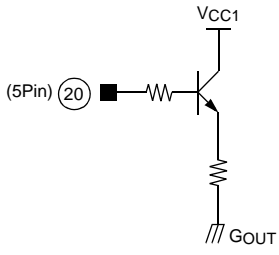
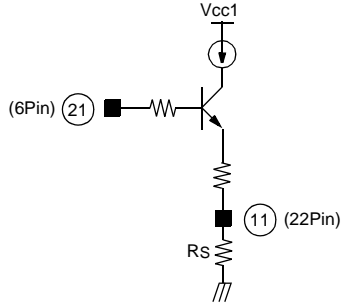
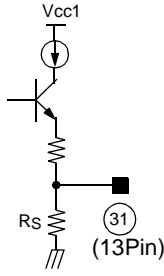
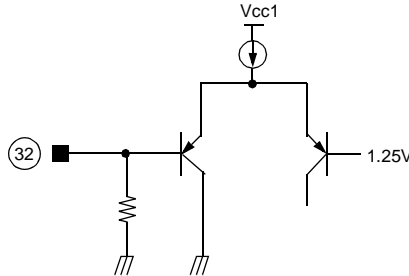
Description	Pin No.	Internal Circuit
Speed Control (Voltage Control)	32-SDIPH 20 28-SSOPH 5	
Voltage Control Reference	32-SDIPH 21 28-SSOPH 6	
Torque Ripple Control	32-SDIPH 31 28-SSOPH 13	
Forward & Reverse Control	32-SDIPH 32 28-SSOPH 14	

Equivalent Circuits (32-SDIPH: O , 28-SSOPH: (#)) (Continued)

Description	Pin No.	Internal Circuit
FG AMP.	32-SDIPH 27, 28, 29, 30 28-SSOPH 9, 10, 11, 12	
Phase Stabilization	32-SDIPH 16, 18 28-SSOPH 1, 3	

Absolute Maximum Ratings (Ta=25°C)

Parameter	Symbol	Value	Unit	Remark
Supply Voltage (Signal)	VCC1max	7	V	-
Supply Voltage (Power)	VCC2max	28	V	-
Maximum Output Current	I _{Omax}	1.5 ^{note1}	A / Phase	VCC1=5V, VCC2=16V
Power Dissipation	P _d	2.4 ^{note2}	W	32SDIPH-400
		1.7 ^{note2}	W	28SSOPH-375
		2.5 ^{note2}	W	28SSOPH-375SG2
Junction Temperature	T _J	150	°C	VCC1=5V, VCC2=16V
Operating Temperature	T _{OPR}	-25 ~ +75	°C	
Storage Temperature	T _{STG}	-40 ~ +125	°C	

Note:

- Duty 1 / 100, pulse width 500μs
- 1) When mounted on glass epoxy PCB (76.2 × 114 × 1.57mm)
 2) Power dissipation reduces 13.6mW / °C for using above Ta=25°C. (32SDIPH Type)
 Power dissipation reduces 19.2mW / °C for using above Ta=25°C. (28SSOPH Type)
 Power dissipation reduces 20.0mW / °C for using above Ta=25°C. (28SSOPH -SG2 Type)
- Do not exceed P_d and SOA(Safe Operating Area).

Power Dissipation Curve

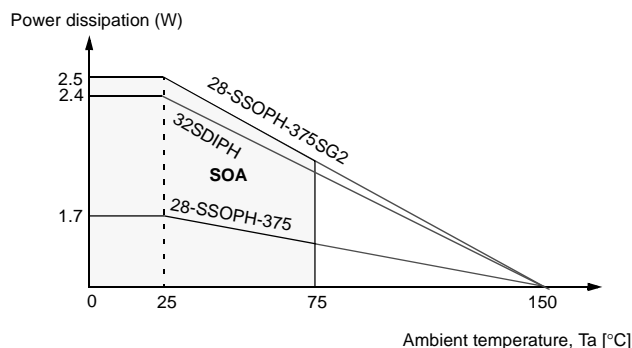

Recommended Operating Conditions (Ta=25°C)

Parameter	Symbol	Value	Unit
Operating Supply Voltage (Signal)	VCC1	4.5 ~ 5.5	V
Operating Supply Voltage (Power)	VCC2	8 ~ 27	V

Electrical Characteristics

(VCC1=5V, VCC2=16V, RS=0.5Ω, Ta=25°C, unless otherwise specified)

Block	Parameter	Symbol	Conditions	Min.	Typ.	max.	Unit	
Total	Quiescent Input Current 1	ICC1	VCC1=5V, VFR=5V	5.0	8.5	12.0	mA	
	Quiescent Input Current 3	ICC3	VCC1=7V, VFR=5V	6.0	10.0	15.0	mA	
	Quiescent Input Current	IO1	VCC2=16V, VLIM=0V	-	1.5	5.0	mA	
	Quiescent Input Current (Max.)	IO3	VCC2=27V, VLIM=VREF	-	2.7	7.0	mA	
Output	Current Limit Level	GML1	RS=0.5Ω	32-SDIPH	0.61	0.67	0.73	A / V
				28-SSOPH	0.46	0.52	0.58	
	Control Gain	GM1	VIN=0V	32-SDIPH	0.9	1.0	1.1	A / V
				28-SSOPH	0.7	0.8	0.9	
	Output Amp. Saturation Voltage 4 (Outflow Current)	VSU4	IOUT=0.8A / Phase	-	1.8	2.0	V	
	Output Amp. Saturation Voltage 4 (Inflow Current)	VSD4	IOUT=0.8A / Phase	-	1.8	2.0	V	
	Limit Current Gap Of Phases	LD1	LIU2-LIWU2	-20	0	20	mA	
	Current Gap Of Phases	D1	lVU1-lWU1	-20	0	20	mA	
	Phase Output Wave Frequency 1	PF1	15kHz, 5Vp-p	2.45	2.5	2.55	kHz	
Phase Output Wave Frequency 4	PF4	10kHz, 5Vp-p	1.62	1.67	1.72	kHz		
Control	Current Limit Input Current	I19	-	-	350	2000	nA	
	Control Input Current	I20	-	-	350	2000	nA	
	Input Offset Voltage U	VO2U	-	-50	0	50	mV	
Rotation Control	CW Voltage Range	VFRU	-	1.0	1.3	1.6	V	
FG amp & comp	FG Amp. Input DC Voltage	V28(10)	32-SDIPH (28-SSOPH)	2.2	2.5	2.8	V	
	FG Amp. Reference Voltage	V27(9)	32-SDIPH (28-SSOPH)	2.2	2.5	2.8	V	
	FG Amp. Voltage Gain	FGAV1	FGIN3=10kHz, 60mVp-p	28	31	34	Times	
	FG Comp. Output Frequency	FCOMP	FGAMP0=3Vp-p (1kHz)	0.9	1	1.1	kHz	
	FG Comp. Downward Input Threshold Voltage	VTHDW	FGAMP0=3→2 Sweep	2.40	2.45	2.50	V	
	FG Comp. UPward Input Threshold Voltage	VTHUP	FGAMP0=2→3 Sweep	2.50	2.55	2.60	V	
	FG Comp. Hysteresis	VHYS	-	20	100	180	mV	
	FG Output High Voltage	FGHI	FGIN3=3V	4.2	-	-	V	
	FG Output Low Voltage	FGLO	FGIN3=2V	-	-	0.4	V	

Application Information (32-SDIPH: O , 28-SSOPH: (#))

1. Hall Input

The input signal of the hall sensor requires larger amplitude than 100mVo-p. The operating voltage level of the hall sensor is from 1.2V ~ $V_{CC1}-0.8V$.

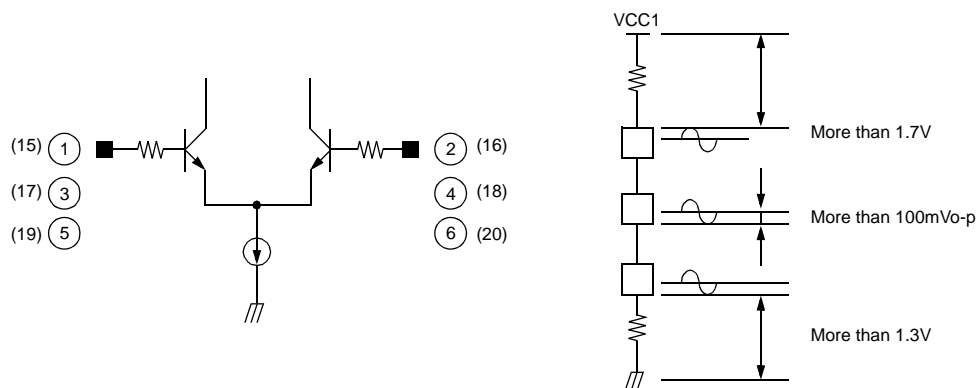

2. Output Current Detection

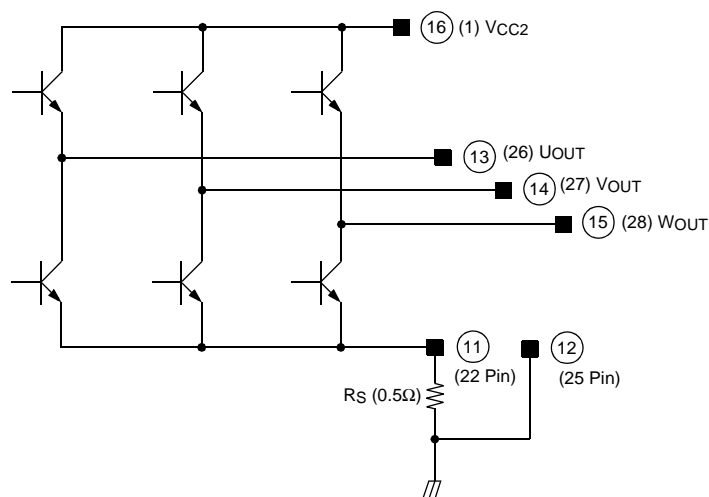

The R_S (Output current sensing resistor) is connected to G_{OUT} and Approx. 0.5Ω . It converts motor current to a voltage which is feedback amplifier.

3. Motor Speed Control (Input Current Limitation)

The maximum output current is limited by the I_{LIM} (Current limiting) voltage.

If current limitation is not in use then connect it to V_{CC1} .

The control gain is approx. $0.67A/V$ as follows.

$$GML = \Delta I_O / \Delta V_{LIM} = (I_{O2} - I_{O1}) / (V_{LIM2} - V_{LIM1}), \text{ where } V_{LIM1} = 1.45V \rightarrow \text{Output current} = I_{O1}$$

$$V_{LIM2} = 1.55V \rightarrow \text{Output current} = I_{O2}$$

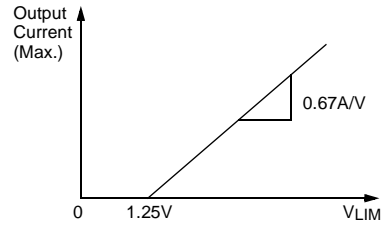
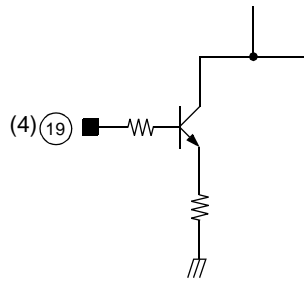

4. Motor Speed Control (Input Voltage Control)

Motor speed control is possible when $V_{CTL} \geq V_{REF}$.
 The control gain is approx. 1.0A/V as follows.

$$GML = \Delta I_O / \Delta V_{CTL} = (I_{O2} - I_{O1}) / (V_{CTL2} - V_{CTL1}), \text{ where } V_{REF} = 2.5V, V_{CTL1} = 2.6V \rightarrow \text{Output current} = I_{O1}$$

$$V_{REF} = 2.5V, V_{CTL2} = 2.7V \rightarrow \text{Output current} = I_{O2}$$

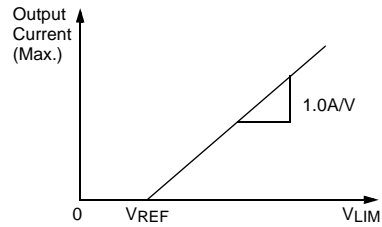
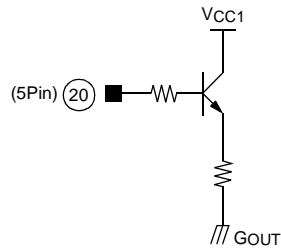

5. Voltage Control Reference

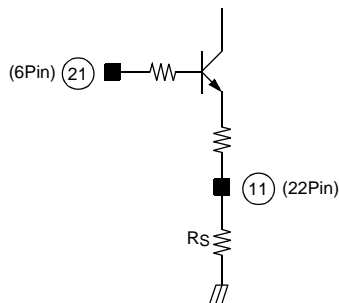

The input voltage range is $2V \leq V_{REF} \leq (V_{CC1} - 2V)$.

6. Torque Ripple Control

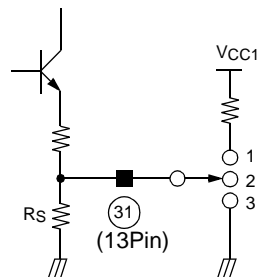

The motor torque ripple is controlled by the TRCTL (Torque ripple control) voltage as follows.

1. GND
2. Normal Mode
3. Control Mode

7. Forward & Reverse Rotation Control

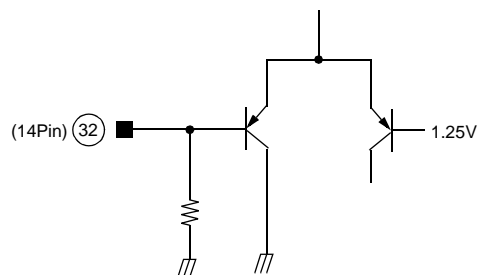

Forward mode: $V_{FRCTL} \geq 1.8V$

Reverse mode: $V_{FRCTL} \leq 0.8V$

8. FG Amp

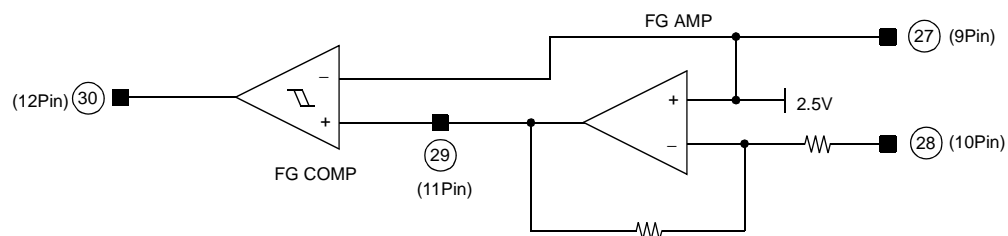

9. Phase Stabilization

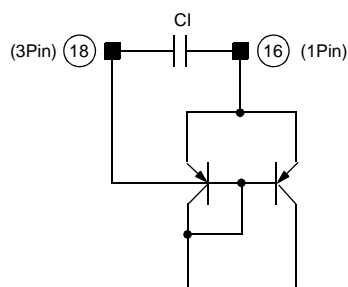

Be inserted a capacitor between VCC2.

This capacitor, approx. $0.1\mu F$ is for the phase stabilization of the circuit.

Timing Chart

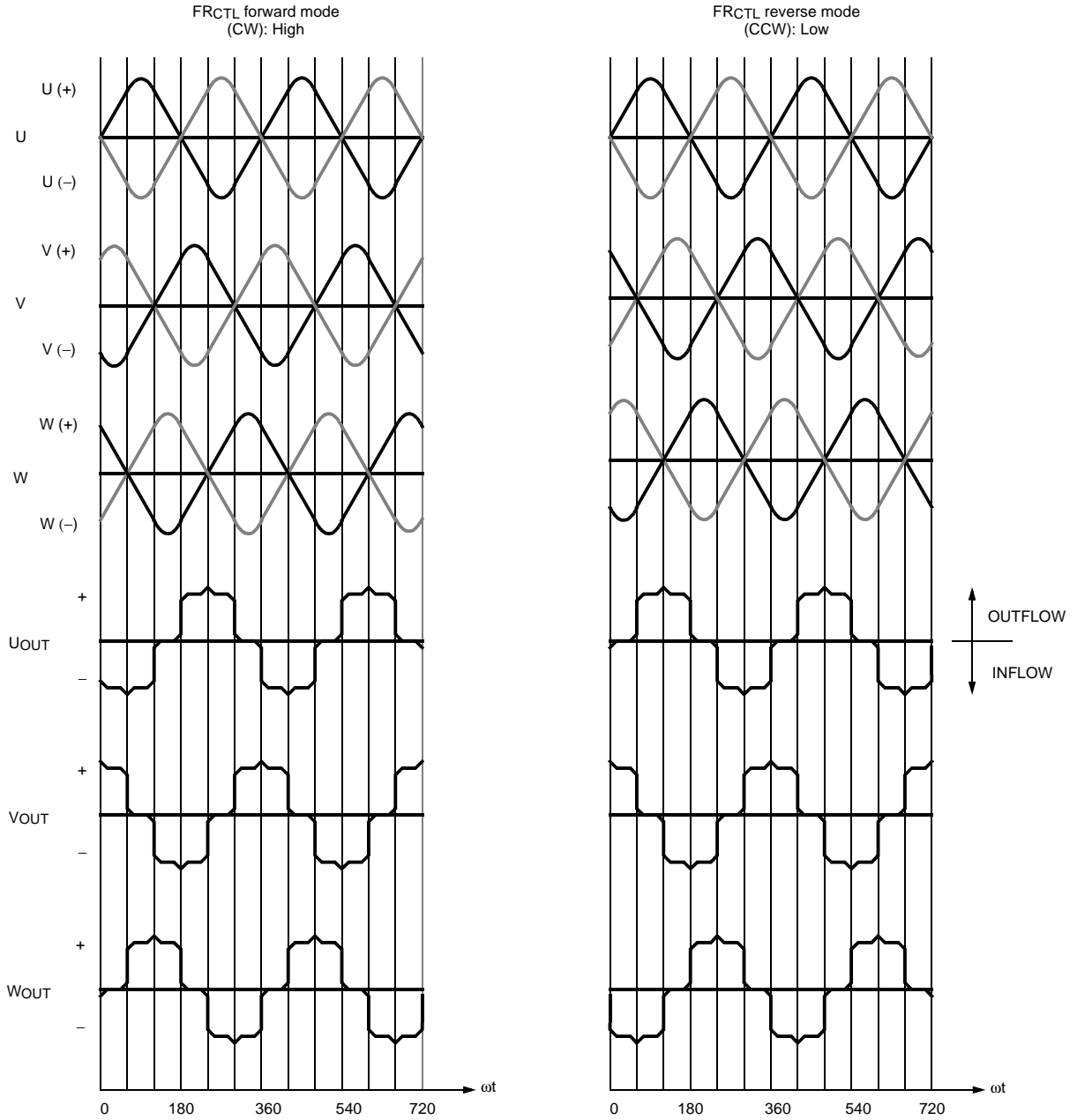

Test Circuits (32-SDIPH)

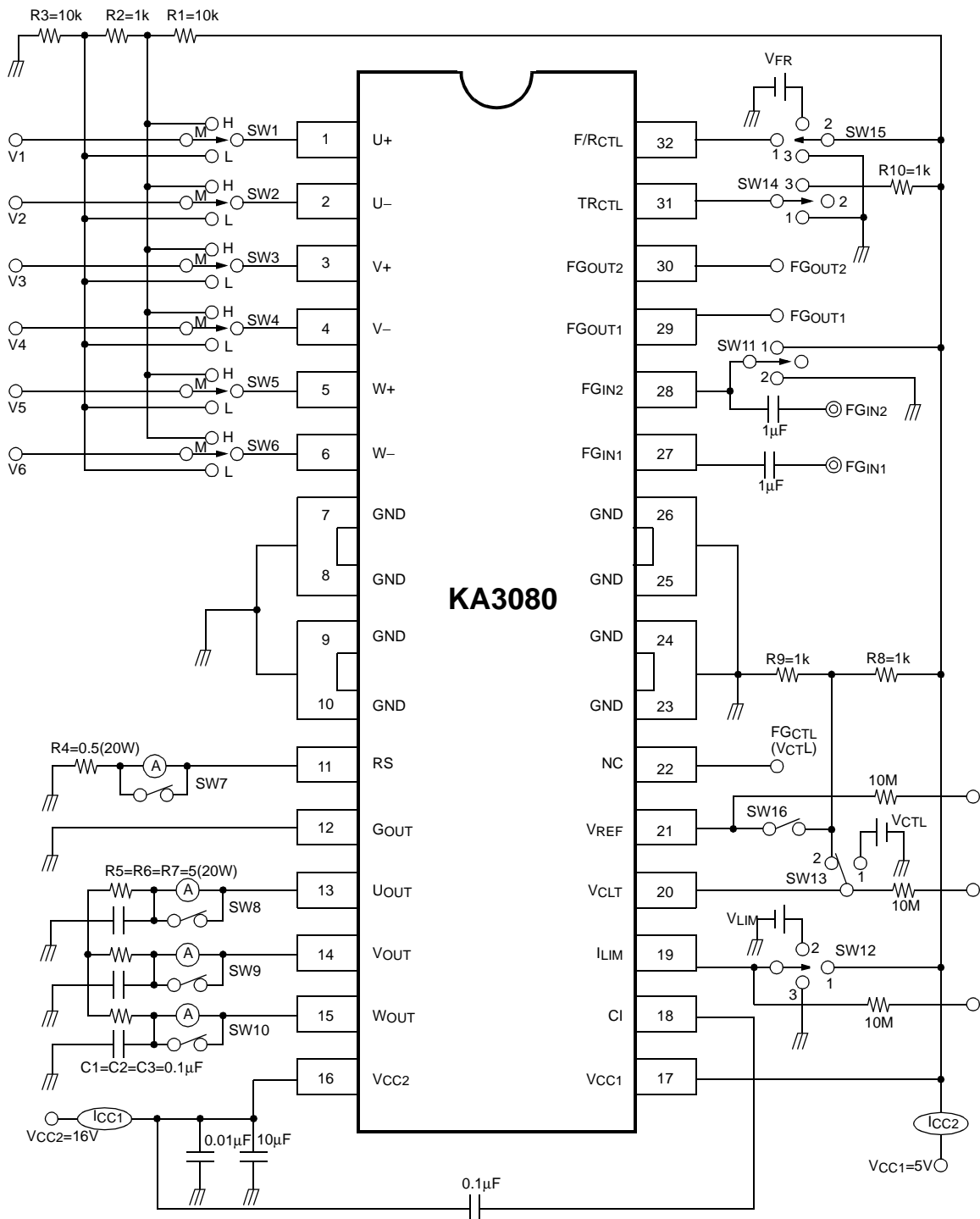

Test Circuits (28-SSOPH)

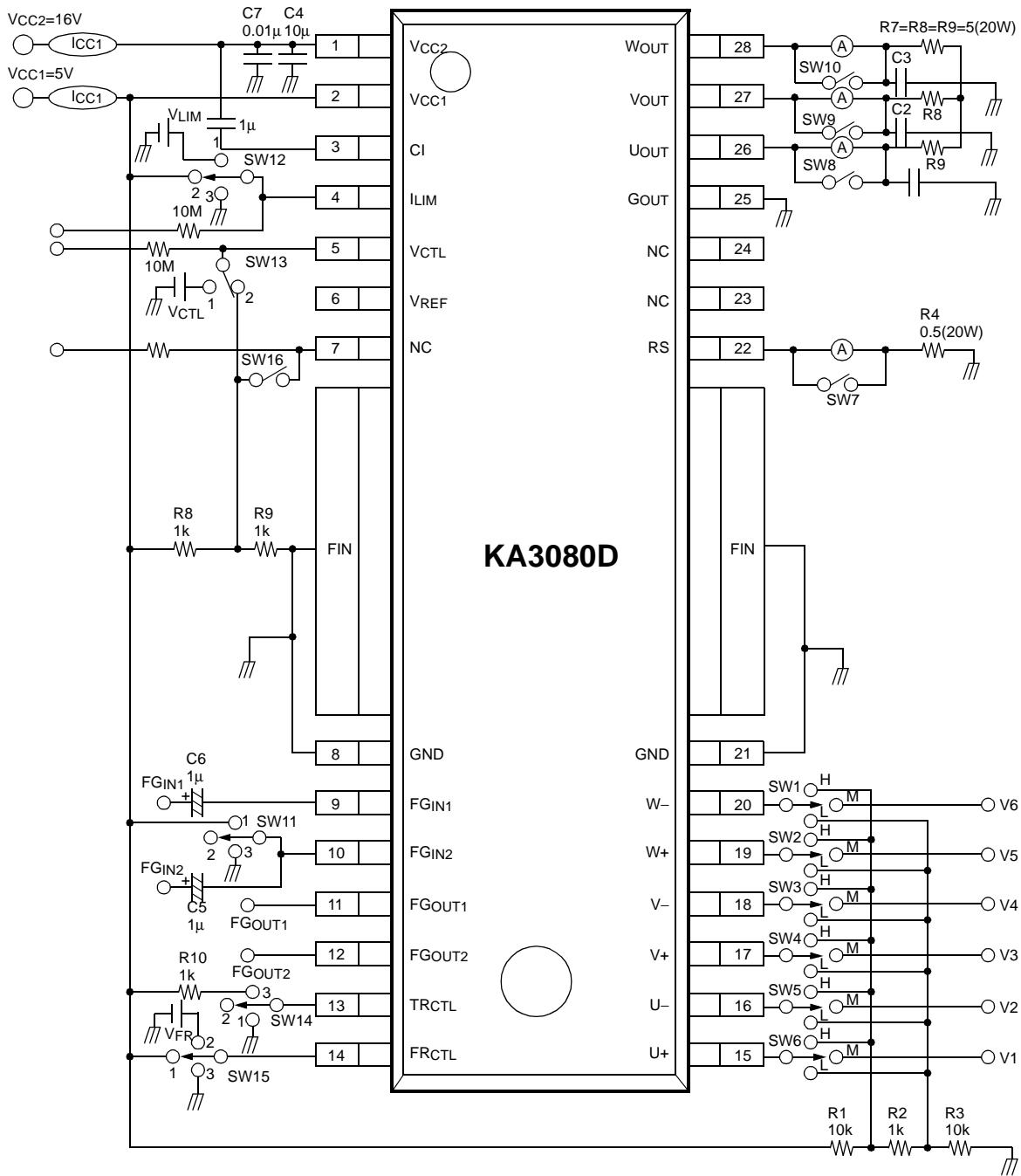

Typical Application Circuits (32-SDIPH)

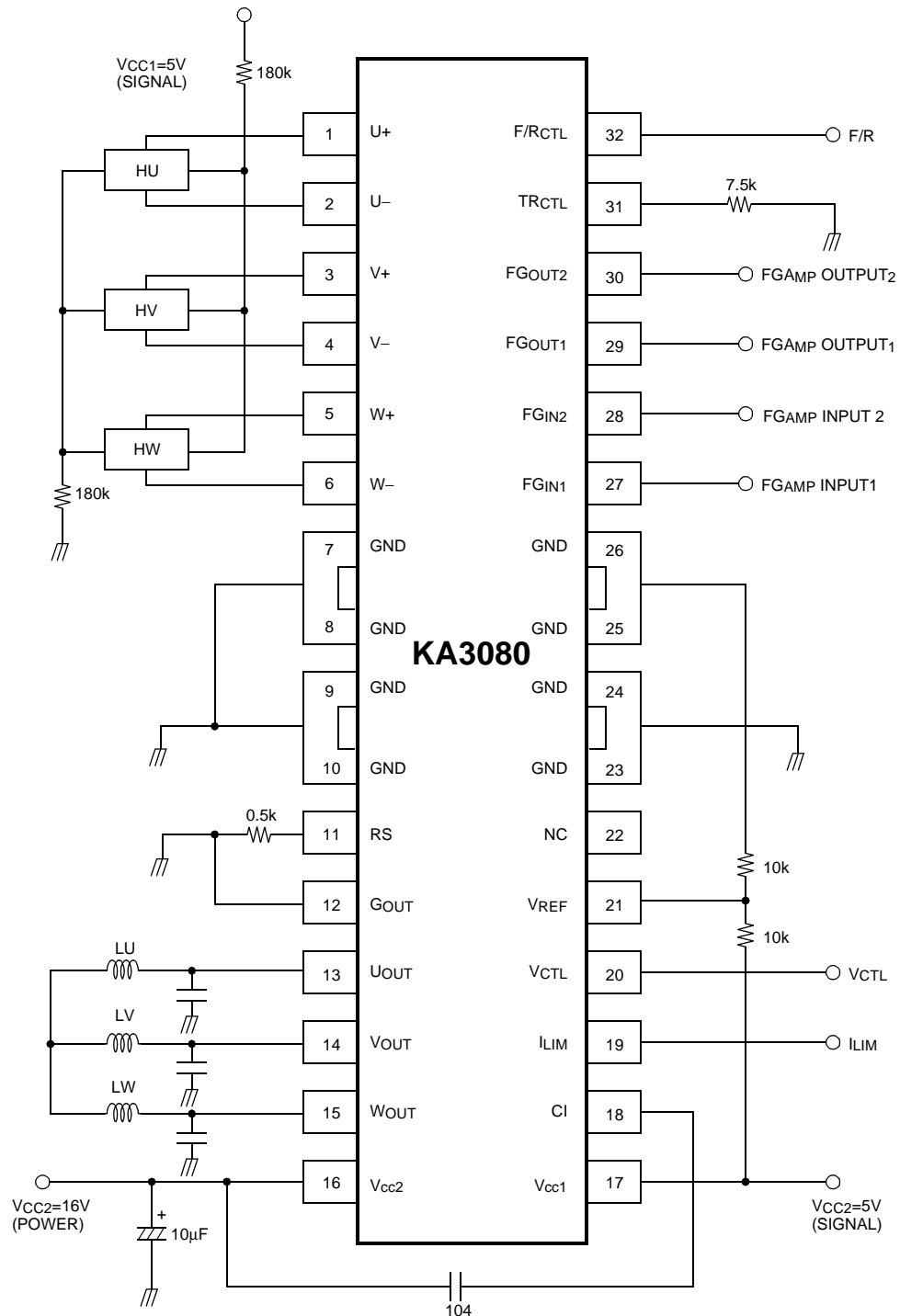

Typical Application Circuits (28-SSOPH)

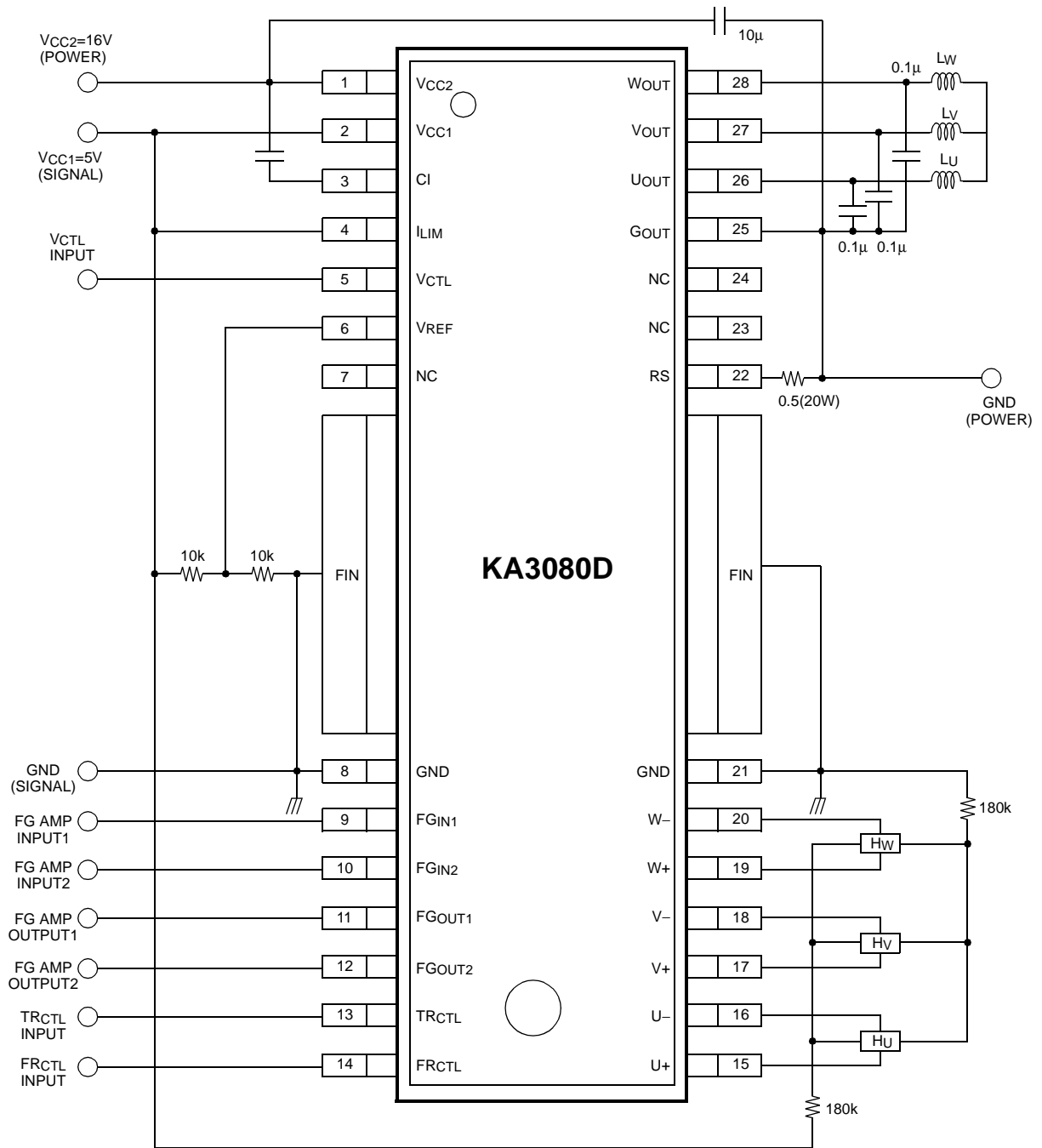

DISCLAIMER

FAIRCHILD SEMICONDUCTOR RESERVES THE RIGHT TO MAKE CHANGES WITHOUT FURTHER NOTICE TO ANY PRODUCTS HEREIN TO IMPROVE RELIABILITY, FUNCTION OR DESIGN. FAIRCHILD DOES NOT ASSUME ANY LIABILITY ARISING OUT OF THE APPLICATION OR USE OF ANY PRODUCT OR CIRCUIT DESCRIBED HEREIN; NEITHER DOES IT CONVEY ANY LICENSE UNDER ITS PATENT RIGHTS, NOR THE RIGHTS OF OTHERS.

LIFE SUPPORT POLICY

FAIRCHILD'S PRODUCTS ARE NOT AUTHORIZED FOR USE AS CRITICAL COMPONENTS IN LIFE SUPPORT DEVICES OR SYSTEMS WITHOUT THE EXPRESS WRITTEN APPROVAL OF THE PRESIDENT OF FAIRCHILD SEMICONDUCTOR CORPORATION. As used herein:

1. Life support devices or systems are devices or systems which, (a) are intended for surgical implant into the body, or (b) support or sustain life, and (c) whose failure to perform when properly used in accordance with instructions for use provided in the labeling, can be reasonably expected to result in a significant injury of the user.
2. A critical component in any component of a life support device or system whose failure to perform can be reasonably expected to cause the failure of the life support device or system, or to affect its safety or effectiveness.