

FM IF SYSTEM FOR CAR RADIOS

The KA2245 is a monolithic integrated circuit consisting of an FM IF amplifier and detector. It is suitable for car radios.

FUNCTIONS

- 3-stage IF amplifier.
- Peak detector.

FEATURES

- Suitable for FM car radios.
- Wide operating supply voltage range: $V_{CC} = 8V \sim 14V$.
- High detector output voltage ($V_O = 500mV, Typ$).
- Excellent AM rejection: $AMR = 50dB (Typ)$.
- High sensitivity: $V_{I(LIM)} = 50dB\mu V (Typ)$.
- Simplified single coil tuning.
- Low distortion ($THD = 0.1\%: Typ$).
- Minimum number of external parts required.

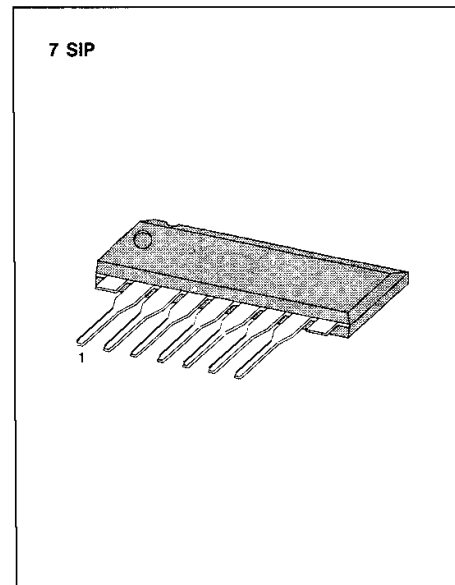

ORDERING INFORMATION

Device	Package	Operating Temperature
KA2245	7 SIP	-20°C ~ +70°C

BLOCK DIAGRAM

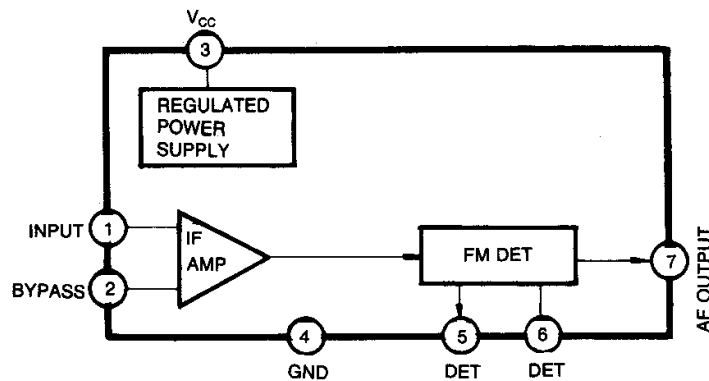

Fig. 1

ABSOLUTE MAXIMUM RATINGS ($T_a = 25^\circ\text{C}$)

Characteristic	Symbol	Value	Unit
Supply Voltage	V_{CC}	15	V
Input Voltage	V_i	0.7	V
Power Dissipation	P_D	400	mW
Operating Temperature	T_{OPR}	-20 ~ +70	$^\circ\text{C}$
Storage Temperature	T_{STG}	-40 ~ +125	$^\circ\text{C}$

* : Derated above $T_a = 25^\circ\text{C}$ in the proportion of $4\text{mW}/^\circ\text{C}$

ELECTRICAL CHARACTERISTICS

($T_a = 25^\circ\text{C}$, $V_{CC} = 12\text{V}$, $f = 10.7\text{MHz}$, $f_m = 400\text{Hz}$)

Characteristic	Symbol	Test Conditions	Min	Typ	Max	Unit
Quiescent Circuit Current	I_{CCQ}	$V_i = 0$	8	12	15	mA
-3dB Limiting Sensitivity	$V_{i(LIM)}$	-3dB point from V_o $V_i = 80\text{dB}\mu\text{V}$, $\Delta f = \pm 75\text{KHz}$		50	55	$\text{dB}\mu$
AM Rejection Ratio	AMR	FM: $\Delta f = \pm 75\text{KHz dev}$ AM: 30% Mod $V_i = 80\text{dB}\mu\text{V}$		50		dB
Detector Output Voltage	V_o	$\Delta f = \pm 75\text{KHz dev}$ $V_i = 80\text{dB}\mu\text{V}$	300	500	700	mV
Total Harmonic Distortion	THD	$\Delta f = \pm 22.5\text{KHz dev}$ $V_i = 80\text{dB}\mu\text{V}$		0.2		%
Signal to Noise Ratio	S/N	$\Delta f = \pm 75\text{KHz dev}$ $V_i = 80\text{dB}\mu\text{V}$		60		dB

TEST CIRCUIT

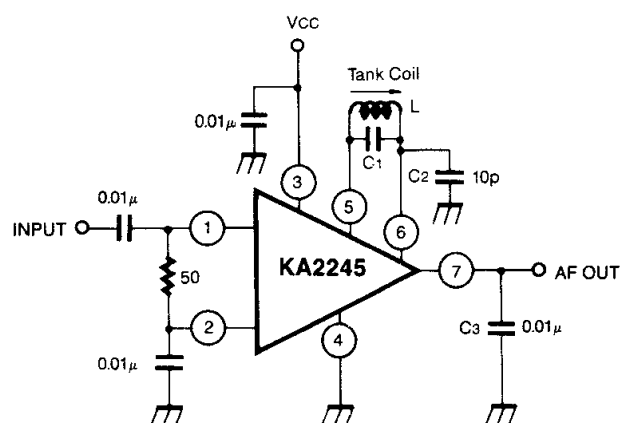

APPLICATION CIRCUIT

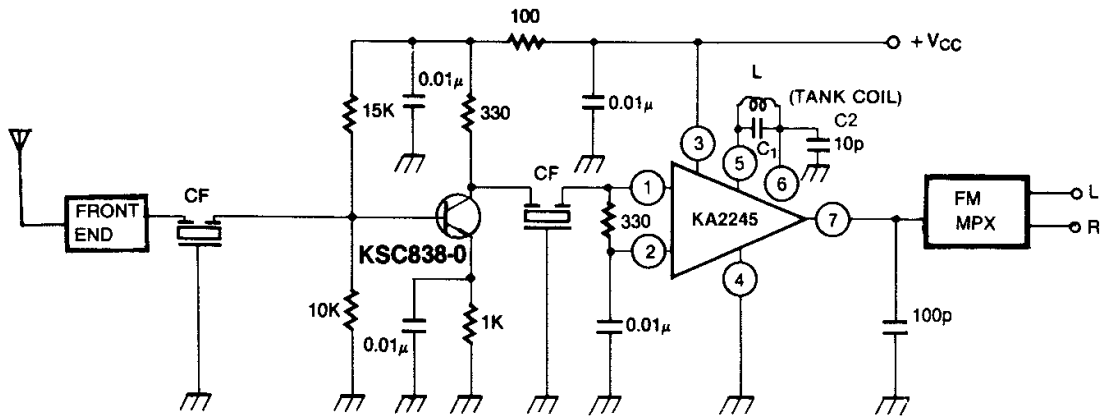
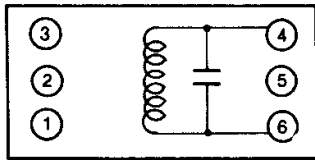

Fig. 3

$$f_o = \frac{1}{2\pi\sqrt{L(C_1 + \frac{C_2}{2})}}$$

COIL SPECIFICATIONS



C _o (pF)	f (MHz)	O _o (%)	Turns		
			4-6		
27	10.7	150	18		