

**Wireless LAN Integrated Medium Access Controller with Baseband Processor with Mini-PCI**



The Intersil ISL3874 Wireless LAN Integrated Medium Access Controller with Integrated Baseband Processor is part of the PRISM® 2.4GHz radio

chip set. The ISL3874 directly interfaces with the Intersil's IF QMODEM (HFA3783). Adding Intersil's RF/IF Converter (ICW3685) and Intersil's Power Amp (HFA3983/4/5) offers the designer a complete end-to-end WLAN Chip Set solution. Protocol and PHY support are implemented in firmware thus, supporting customization of the WLAN solution.

Firmware implements the full IEEE 802.11 Wireless LAN MAC protocol. It supports BSS and IBSS operation under DCF, and operation under the optional Point Coordination Function (PCF). Low level protocol functions such as RTS/CTS generation and acknowledgment, fragmentation and de-fragmentation, and automatic beacon monitoring are handed without host intervention. Active scanning is performed autonomously once initiated by host command. Host interface command and status handshakes allow concurrent operations from multi-threaded I/O drivers. Additional firmware functions specific to access point applications are also available.

The ISL3874 has on-board A/Ds and D/A for analog I and Q inputs and outputs, for which the HFA3783 IF QMODEM is recommended. Differential phase shift keying modulation schemes DBPSK and DQPSK, with data scrambling capability, are available along with Complementary Code Keying to provide a variety of data rates. Both Receive and Transmit AGC functions with 7-bit AGC control obtain maximum performance in the analog portions of the transceiver.

Built-in flexibility allows the ISL3874 to be configured through a general purpose control bus, for a range of applications. The ISL3874 is housed in a thin plastic BGA package suitable for mini PCI board applications.

The ISL3874 is designed to provide maximum performance with minimum power consumption. External pin layout is organized to provide optimal PC board layout to all user interfaces including mini PCI.

**Features**

- Start up modes allow the mini PCI Card Information Structure to be initialized from a serial EEPROM. This Allows Firmware to be Downloaded from the Host, Eliminating the Parallel Flash Memory Device
- Firmware Can Be Loaded from Serial Flash Memory
- Zero Glue Connection to 16-Bit Wide SRAM Devices
- Low Frequency Crystal Oscillator to Maintain Time and Allow Baseband Clock Source to Power Off During Sleep Mode
- High Performance Internal WEP Engine
- Debug Mode Support Tracing Execution from On-Chip Memory
- Programmable MBUS Cycle Extension Allows Accessing of Slow Memory Devices without Slowing the Clock
- Complete DSSS Baseband Processor
- RAKE Receiver with Decision Feedback Equalizer
- Processing Gain . . . . . FCC Compliant
- Programmable Data Rate . . . . . 1, 2, 5.5, and 11Mbps
- Ultra Small Package. . . . . 14mm x 14mm
- Single Supply Operation . . . . . 2.7V to 3.6V
- Modulation Methods. . . . . DBPSK, DQPSK, and CCK
- Supports Full or Half Duplex Operations
- On-Chip A/D and D/A Converters for I/Q Data (6-Bit, 22MSPS), AGC, and Adaptive Power Control (7-Bit)
- Targeted for Multipath Delay Spreads 125ns at 11Mbps, 250ns at 5.5Mbps
- Supports Short Preamble and Antenna Diversity

**Applications**

- Enterprise WLAN Systems
- PCI Card Wireless LAN Adapters
- PCN / Wireless PBX / Wireless Local Loop
- High Data Rate Wireless LAN Systems Targeting IEEE 802.11b Standard
- Wireless LAN Access Points and Bridge Products
- Spread Spectrum WLAN RF Modems
- TDMA or CSMA Packet Protocol Radios

**Ordering Information**

PART NUMBER	TEMP. RANGE (°C)	PACKAGE	PART NUMBER
ISL3874IK	-40 to 85	192 BGA	V192.14x14
ISL3874IK96	-40 to 85	Tape and Reel 1000 Units/Reel	

PRISM® is a registered trademark of Intersil Americas Inc. PRISM and design is a trademark of Intersil Americas Inc.

Simplified Block Diagram

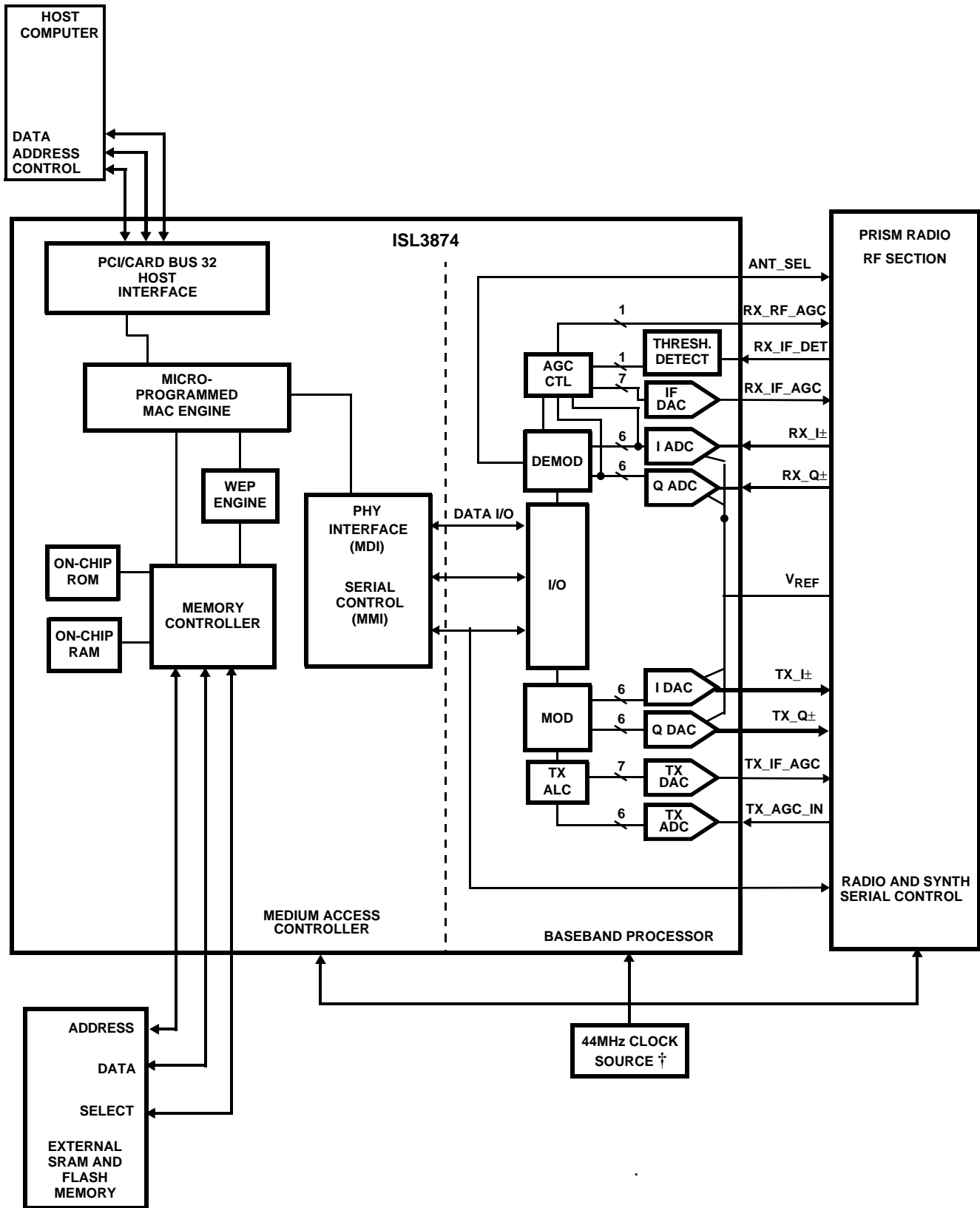

## ISL3874 Signal Descriptions

TABLE 1. HOST INTERFACE PINS

PIN NAME	PIN NUMBER	PIN I/O TYPE	DESCRIPTION
HAD31	A8	5V Tol, CMOS, BiDir	PCI address/data bus bit 31. These signals make up the multiplexed PCI address and data bus on the primary interface. During the address phase of a primary bus PCI cycle, HAD31-HAD0 contain a 32-bit address or other destination information. During the data phase, HAD31-HAD0 contain data.
HAD30	A9	5V Tol, CMOS, BiDir	PCI address/data bus bit 30.
HAD29	C8	5V Tol, CMOS, BiDir	PCI address/data bus bit 29.
HAD28	A10	5V Tol, CMOS, BiDir	PCI address/data bus bit 28.
HAD27	B9	5V Tol, CMOS, BiDir	PCI address/data bus bit 27.
HAD26	B10	5V Tol, CMOS, BiDir	PCI address/data bus bit 26.
HAD25	C9	5V Tol, CMOS, BiDir	PCI address/data bus bit 25.
HAD24	A11	5V Tol, CMOS, BiDir	PCI address/data bus bit 24.
HAD23	B11	5V Tol, CMOS, BiDir	PCI address/data bus bit 23.
HAD22	B12	5V Tol, CMOS, BiDir	PCI address/data bus bit 22.
HAD21	A12	5V Tol, CMOS, BiDir	PCI address/data bus bit 21.
HAD20	A13	5V Tol, CMOS, BiDir	PCI address/data bus bit 20.
HAD19	C12	5V Tol, CMOS, BiDir	PCI address/data bus bit 19.
HAD18	A14	5V Tol, CMOS, BiDir	PCI address/data bus bit 18.
HAD17	C13	5V Tol, CMOS, BiDir	PCI address/data bus bit 17.
HAD16	C14	5V Tol, CMOS, BiDir	PCI address/data bus bit 16.
HAD15	E14	5V Tol, CMOS, BiDir	PCI address/data bus bit 15.
HAD14	E15	5V Tol, CMOS, BiDir	PCI address/data bus bit 14.
HAD13	F16	5V Tol, CMOS, BiDir	PCI address/data bus bit 13.
HAD12	F15	5V Tol, CMOS, BiDir	PCI address/data bus bit 12.
HAD11	F14	5V Tol, CMOS, BiDir	PCI address/data bus bit 11.
HAD10	G16	5V Tol, CMOS, BiDir	PCI address/data bus bit 10.
HAD9	G15	5V Tol, CMOS, BiDir	PCI address/data bus bit 9.
HAD8	G14	5V Tol, CMOS, BiDir	PCI address/data bus bit 8.
HAD7	H15	5V Tol, CMOS, BiDir	PCI address/data bus bit 7.
HAD6	G13	5V Tol, CMOS, BiDir	PCI address/data bus bit 6.
HAD5	J15	5V Tol, CMOS, BiDir	PCI address/data bus bit 5.
HAD4	J14	5V Tol, CMOS, BiDir	PCI address/data bus bit 4.
HAD3	K14	5V Tol, CMOS, BiDir	PCI address/data bus bit 3.
HAD2	K15	5V Tol, CMOS, BiDir	PCI address/data bus bit 2.
HAD1	L14	5V Tol, CMOS, BiDir	PCI address/data bus bit 1.
HAD0	L16	5V Tol, CMOS, BiDir	PCI address/data bus bit 0.
HBE3	C10	5V Tol, CMOS, BiDir	PCI bus commands and byte enables. These signals are multiplexed on the same PCI terminals. During the address phase of a primary bus PCI cycle, HBE3-HBE0 define the bus command. During the data phase, this 4-bit bus is used as byte enables. The byte enables determine which byte paths of the full 32-bit data bus carry meaningful data. HBE3 applies to byte 3 (HAD31-HAD24).
HBE2	B14	5V Tol, CMOS, BiDir	PCI bus commands and byte enables. HBE2 applies to byte 2 (HAD23-HAD16).
HBE1	E16	5V Tol, CMOS, BiDir	PCI bus commands and byte enables. HBE1 applies to byte 1 (HAD15-HAD8).

TABLE 1. HOST INTERFACE PINS (Continued)

PIN NAME	PIN NUMBER	PIN I/O TYPE	DESCRIPTION
HBE0	H16	5V Tol, CMOS, BiDir	PCI bus commands and byte enables. HBE0 applies to byte 0 (HAD7-HAD0).
HINTA	C6	CMOS, Output	PCI Bus Interrupt A
HRESET	D6	5V Tol, CMOS, Input	PCI reset.
HFRAME	B15	5V Tol, BiDir	PCI cycle frame. FRAME is driven by the initiator of a bus cycle. FRAME is asserted to indicate that a bus transaction is beginning, and data transfers continue while this signal is asserted. When FRAME is deasserted, the PCI bus transaction is in the final data phase.
HIRDY	A15	5V Tol, CMOS, BiDir	PCI initiator ready. HIRDY indicates the PCI bus initiators ability to complete the current data phase of the transaction. A data phase is completed on a rising edge of PCLK where both HIRDY and HTRDY are asserted. Until HIRDY and HTRDY are both sampled asserted, wait states are inserted.
HTRDY	A16	5V Tol, CMOS, BiDir	PCI target ready. HTRDY indicates the primary bus targets ability to complete the current data phase of the transaction. A data phase is completed on a rising edge of PCLK when both HIRDY and HTRDY are asserted. Until both HIRDY and HTRDY are asserted, wait states are inserted.
HREQ	B7	CMOS, Output	PCI bus request. HREQ is asserted by the ISL3874 to request access to the PCI bus as an initiator.
HSERR	B16	CMOS, Output	PCI system error. HSERR is an output that is pulsed from the ISL3874 when enabled through the command register indicating a system error has occurred. The ISL3874 need not be the target of the PCI cycle to assert this signal. When HSERR is enabled in the control register, this signal also pulses, indicating that an address parity error has occurred on a CardBus interface.
HSTOP	C16	5V Tol, CMOS, BiDir	PCI cycle stop signal. HSTOP is driven by a PCI target to request the initiator to stop the current PCI bus transaction. HSTOP is used for target disconnects and is commonly asserted by target devices that do not support burst data transfers.
HDEVSEL	D15	5V Tol, CMOS, BiDir	PCI device select. The ISL3874 asserts HDEVSEL to claim a PCI cycle as the target device. As a PCI initiator on the bus, the ISL3874 monitors HDEVSEL until a target responds. If no target responds before timeout occurs, the ISL3874 terminates the cycle with an initiator abort.
HPERR	D16	5V Tol, CMOS, BiDir	PCI bus parity. In all PCI bus read and write cycles, the ISL3874 calculates even parity across the HD31-HAD0 and BE3-BE0 buses. As an initiator during PCI cycles, the ISL3874 outputs this parity indicator with a one-PCLK delay. As a target during PCI cycles, the calculated parity is compared to the initiator parity indicator. A compare error results in the assertion of a parity error (PERR).
HGNT	C7	5V Tol, CMOS, ST Input	PCI bus grant. HGNT is driven by the PCI bus arbiter to grant the ISL3874 access to the PCI bus after the current data transaction has completed. HGNT may or may not follow a PCI bus request, depending on the PCI bus parking algorithm.
HPCLK	A7	5V Tol, CMOS, Input	HPCLK provides timing for all transactions on the PCI bus. All PCI signals are sampled at the rising edge of PCLK.
HPAR	B13	5V Tol, CMOS, BiDir	PCI bus parity.
HIDSEL	C11	5V Tol, CMOS, Input	Initialization device select. HIDSEL selects the ISL3874 during configuration space accesses. HIDSEL can be connected to one of the upper 24 PCI address lines on the PCI bus.
HPME	B8	CMOS, Output	Power Management Event Output. HPME provides output for PME signals.

TABLE 2. MEMORY INTERFACE PINS

PIN NAME	PIN NUMBER	PIN I/O TYPE	DESCRIPTION
PL4-MA19	A4	CMOS BiDir, 2mA	MBUS Address Bit 19, needed to address between 512KB and 1MB of data store
MA18	A3	CMOS BiDir, 2mA	MBUS Address Bit 18
MA17	B4	CMOS BiDir, 2mA	MBUS Address Bit 17
MA16	C3	CMOS TS Output, 2mA	MBUS Address Bit 16
MA15	B3	CMOS TS Output, 2mA	MBUS Address Bit 15
MA14	A1	CMOS TS Output, 2mA	MBUS Address Bit 14
MA13	C2	CMOS TS Output, 2mA	MBUS Address Bit 13
MA12	E3	CMOS TS Output, 2mA	MBUS Address Bit 12
MA11	B1	CMOS TS Output, 2mA	MBUS Address Bit 11
MA10	D2	CMOS TS Output, 2mA	MBUS Address Bit 10
MA9	D3	CMOS TS Output, 2mA	MBUS Address Bit 9
MA8	C1	CMOS TS Output, 2mA	MBUS Address Bit 8
MA7	F4	CMOS TS Output, 2mA	MBUS Address Bit 7
MA6	E2	CMOS TS Output, 2mA	MBUS Address Bit 6
MA5	D1	CMOS TS Output, 2mA	MBUS Address Bit 5
MA4	F2	CMOS TS Output, 2mA	MBUS Address Bit 4
MA3	E1	CMOS TS Output, 2mA	MBUS Address Bit 3
MA2	F3	CMOS TS Output, 2mA	MBUS Address Bit 2
MA1	F1	CMOS TS Output, 2mA	MBUS Address Bit 1
MA0 / MWEH-	G2	CMOS TS Output, 2mA, 50K Pull Up	MBUS Write Enable, high byte. Asserted on writes to the high-order byte of x16 memory devices that use the JEDEC 4-wire control interface. Also asserted (as MA[0]) when accessing the odd (high-order) byte of a word stored in a x8 memory device. During word accesses of x8 memory, the odd byte is accessed first.
MD15	H4	CMOS, BiDir, 2mA, 50K Pull Up	MBUS Data Bit 15
MD14	G1	CMOS, BiDir, 2mA, 50K Pull Up	MBUS Data Bit 14
MD13	H3	CMOS, BiDir, 2mA, 50K Pull Down	MBUS Data Bit 13
MD12	H2	CMOS, BiDir, 2mA, 50K Pull Down	MBUS Data Bit 12
MD11	H1	CMOS, BiDir, 2mA, 50K Pull Up	MBUS Data Bit 11
MD10	J3	CMOS, BiDir, 2mA, 50K Pull Up	MBUS Data Bit 10
MD9	M1	CMOS, BiDir, 2mA, 50K Pull Up	MBUS Data Bit 9
MD8	M3	CMOS, BiDir, 2mA, 50K Pull Down	MBUS Data Bit 8
MD7	M2	CMOS, BiDir, 2mA 50K Pull Down	MBUS Data Bit 7
MD6	N1	CMOS, BiDir, 2mA, 50K Pull Down	MBUS Data Bit 6
MD5	N3	CMOS, BiDir, 2mA, 50K Pull Down	MBUS Data Bit 5
MD4	P1	CMOS, BiDir, 2mA, 50K Pull Down	MBUS Data Bit 4
MD3	N2	CMOS, BiDir, 2mA, 50K Pull Down	MBUS Data Bit 3
MD2	P3	CMOS, BiDir, 2mA, 50K Pull Down	MBUS Data Bit 2
MD1	R1	CMOS, BiDir, 2mA, 50K Pull Down	MBUS Data Bit 1
MD0	P2	CMOS, BiDir, 2mA, 50K Pull Down	MBUS Data Bit 0

TABLE 2. MEMORY INTERFACE PINS (Continued)

PIN NAME	PIN NUMBER	PIN I/O TYPE	DESCRIPTION
MLBE	L3	CMOS BiDir Output, 2mA, 50K Pull Up	MBUS Lower Byte Enable. Asserted when accessing the low-order byte of x16 memory devices that use the JEDEC 5-wire control interface.
MOE	L1	CMOS TS Output, 2mA, 50K Pull Up	Memory Output Enable; asserted on memory reads
MWE/ MWEL	L2	CMOS TS Output, 2mA, 50K Pull Up	Low (or only) Byte Memory Write Enable. Asserted on writes to x8 memory devices, x16 memory devices that use the JEDEC 5-wire control interface, or writes to the low-order byte of x16 memory devices that use the JEDEC 4-wire control interface.
RAMCS	K2	CMOS TS Output, 2mA, 50K Pull Up	RAM Select; asserted on MBUS cycles when the address is in the area configured as RAM
NVCS	K1	CMOS TS Output, 2mA, 50K Pull Up	NV Memory Select; asserted on MBUS cycles when the address is in the area configured as non-volatile memory.

TABLE 3. GENERAL PURPOSE PORT PINS

PIN NAME	PIN NUMBER	PIN I/O TYPE	DESCRIPTION OF FUNCTION (IF OTHER THAN IO PORT)
PJ4	T2	CMOS BiDir, 2mA, 50K Pull Down	PE1. PE1 and PE2 are bit-encoded functions that control the RF and IF sections.
PJ5	T4	CMOS BiDir, 2mA, 50K Pull Down	LE_IF. LE_IF and LE_RF are the corresponding serial enables for the IF and RF chips. The trailing edge of the latch enables (LE) are required to latch the data in the input register. The last 20 bits of data before the trailing edge of enables are latched in.
PJ6	P4	CMOS BiDir, 2mA	LED1.
PJ7	T3	CMOS BiDir, 2mA, 50K Pull Down	RADIO_PE. This signal is the power enable to the RF and IF components, but not the baseband.
PK0	R5	CMOS BiDir, 2mA, ST, 50K Pull Down	LE_RF. LE_RF and LE_IF are the corresponding serial enables for the RF and IF chips. The trailing edge of the latch enables (LE) are required to latch the data in the input register. The last 20 bits of data before the trailing edge of enable are latched in.
PK1	R4	CMOS BiDir, 2mA, 50K Pull Down	SYNTHCLK. Separate signals, SYNTHCLK and SYNTHDATA, are used to program the synthesizer through bit manipulation in firmware.
PK2	N7	CMOS BiDir, 2mA, 50K Pull Down	SYNTHDATA. Separate signals, SYNTHDATA and SYNTHCLK, are used to program the synthesizer through bit manipulation in firmware.
PK3	R6	CMOS BiDir, 2mA, 50K Pull Down	PA_PE. This signal, when asserted high, enables the Tx section of the Modulator/Demodulator and RF/IF up/down converter circuits.
PK4	T5	CMOS BiDir, 2mA, 50K Pull Down	PE2. PE2 and PE1 are bit-encoded functions that control the RF and IF sections.
PK7	P7	CMOS BiDir, 2mA, 50K Pull Down	CAL_EN. Calibrates the Rx function to eliminate DC offset in the Rx chain.
PL3	P8	CMOS BiDir, 2mA, 50K Pull Up	TR_SW_BAR. Antenna Diversity Control
PL7	T6	CMOS BiDir, 2mA, 50K Pull Down	TR_SW. Antenna Diversity Control

TABLE 4. SERIAL EEPROM PORT CONNECTIONS

PIN NAME	PIN NUMBER	PIN I/O TYPE	DESCRIPTION
PJ0	P5	CMOS BiDir, 2mA, 50K Pull Up	SCLK, serial clock for serial EEPROM devices
PJ1	T1	CMOS BiDir, 2mA, 50K Pull Down	Serial Data Out (SD) used on serial EEPROM devices which require three and four wire interfaces, example: AT45DB011
PJ2	R3	CMOS BiDir, 2mA, 50K Pull Down	Serial Data In (MISO) used on serial EEPROM devices, Used in four wire serial devices only. Not currently supported in software. Consult the factory for additional updates on this option.
TCLKIN(CS)	L4	I/O, 50K Pull Down	CS used for Chip Select Output for Serial Devices which have a 4 wire interface like the AST45DB011 and also serial data on two wire devices like the 24C08.

TABLE 5. CLOCKS PORT PINS

PIN NAME	PIN NUMBER	PIN I/O TYPE	DESCRIPTION
XTALIN	J2	Analog Input	32.768kHz Crystal Input
XTALOUT	J1	CMOS Output, 2mA	32.768kHz Crystal Output
CLKOUT	A2	CMOS, TS Output, 2mA	Clock Output (Selectable as MCLK, TCLK, or TOUT0)
BBP_CLK	J16	Input	Baseband Processor Clock. The nominal frequency for this clock is 44 MHz.

TABLE 6. BASEBAND PROCESSOR RECEIVER PORT PINS

PIN NAME	PIN NUMBER	PIN I/O TYPE	DESCRIPTION
RX_IF_AGC	T16	O	Analog drive to the IF AGC control.
RX_RF_AGC	P16	O	Drive to the RF AGC stage attenuator. CMOS digital.
RX_IF_DET	R10	I	Analog input to the receive power A/D converter for AGC control.
RXI+	R7	I	Analog input to the internal 6-bit A/D of the In-phase received data. Balanced differential.
RXI-	T7	I	Analog input to the internal 6-bit A/D of the In-phase received data. Balanced differential.
RXQ+	R9	I	Analog input to the internal 6-bit A/D of the Quadrature received data. Balanced differential.
RXQ-	T9	I	Analog input to the internal 6-bit A/D of the Quadrature received data. Balanced differential.

TABLE 7. BASEBAND PROCESSOR TRANSMITTER PORT PINS

PIN NAME	PIN NUMBER	PIN I/O TYPE	DESCRIPTION
TX_AGC_IN	T10	I	Input to the transmit power A/D converter for transmit AGC control.
TX_IF_AGC	R16	O	Analog drive to the transmit IF power control.
TXI+	R12	O	TX Spread baseband I digital output data. Data is output at the chip rate. Balanced differential.
TXI-	T12	O	TX Spread baseband I digital output data. Data is output at the chip rate. Balanced differential.
TXQ+	R14	O	TX Spread baseband Q digital output data. Data is output at the chip rate. Balanced differential.
TXQ-	T14	O	TX Spread baseband Q digital output data. Data is output at the chip rate. Balanced differential.

TABLE 8. MISCELLANEOUS CONTROL PORT PINS

PIN NAME	PIN NUMBER	PIN I/O TYPE	DESCRIPTION
GRESET	L15	I	Global Reset for MAC, Active LOW
TCLKIN(CS)	L4	I/O, 50K Pull Down	CS used for Chip Select Output for Serial Devices which have a 4 wire interface like the AST45DB011 and also serial data on two wire devices like the 24C08.
$\overline{\text{ANTSEL}}$	N15	O	The antenna select signal changes state as the receiver switches from antenna to antenna during the acquisition process in the antenna diversity mode. This is a complement for ANTSEL (pin 40) for differential drive of antenna switches.
ANTSEL	N16	O	The antenna select signal changes state as the receiver switches from antenna to antenna during the acquisition process in the antenna diversity mode. This is a complement for $\overline{\text{ANTSEL}}$ (pin 39) for differential drive of antenna switches.
Test_Mode	C4	I	Must be tied to GND.
CompCap1	R15	I	Compensation Capacitor.
CompCap2	R13	I	Compensation Capacitor.
CompRes1	T15	I	Compensation Resistor.
CompRes2	P13	I	Compensation Resistor.
$\overline{\text{DBG4}}$ (MPCIACT)	B6	I/O	Manufacturing Debug Signals, Leave Unconnected. Connected to MPCIACT Signal on Mini-PCI Connector.
DBG3 (CLKRUN)	A5	I/O	Manufacturing Debug Signals, Leave Unconnected. Connected to CLKRUN Signal on Mini-PCI Connector.
DBG2 (LED2)	C5	I/O	Manufacturing Debug Signals, Leave Unconnected. Used as LED2 Output Signal.
DBG1	B5	I/O	Manufacturing Debug Signals, Leave Unconnected.
DBG0	A6	I/O	Manufacturing Debug Signals, Leave Unconnected.

TABLE 9. POWER PORT PINS

PIN NAME	PIN NUMBER	PIN I/O TYPE	DESCRIPTION
V <sub>DDA</sub>	M13, P12, R11, T8, R8, P9	Power	Analog DC Power Supply 2.7 - 3.6V.
V <sub>DD</sub>	P6, D4, D7, D9, D11, D14, F13, H13, K16, M15, N5, N4, K4, G3, E4	Power	Digital DC Power Supply 2.7 - 3.6V.
V <sub>SSA</sub>	N13, T13, T11, N9	GND	Analog Ground.
V <sub>sub</sub>	N10, P10	GND	Analog Ground.
GND	B2, D5, D8, D10, D12, D13, E13, H14, J13, N14, N8, N6, R2, M4, K3, J4, G4	GND	Digital Ground.
V <sub>REF</sub>	P11	Input	Voltage Reference for A/Ds and D/As.
I <sub>REF</sub>	N12	Input	Current Reference for internal ADC and DAC devices. Requires 12K resistor to ground.
NC	P15, P14, N11, M14, C15, L13, M16, K13	NC	No Connection.

ST = Schmitt Trigger (Hysteresis), TS = Three-State. Signals ending with "-" are active low.



**Absolute Maximum Ratings**

Supply Voltage . . . . . 4V  
 Input, Output or I/O Voltage . . . . . GND -0.5V to  $V_{CC} + 0.5V$   
 ESD Classification . . . . . Class 2

**Operating Conditions**

Voltage Range . . . . . +3.3V  
 Ambient Temperature Range . . . . . -40°C to 85°C

**Thermal Information**

Thermal Resistance (Typical, Note 1)  $\theta_{JA}$  (°C/W)  
 BGA Package . . . . . 56  
 Maximum Storage Temperature Range . . . . . -65°C to 150°C  
 Maximum Junction Temperature . . . . . 100°C  
 Maximum Soldering Temperature . . . . . See Tech Brief TB334

**CAUTION:** Stresses above those listed in "Absolute Maximum Ratings" may cause permanent damage to the device. This is a stress only rating and operation of the device at these or any other conditions above those indicated in the operational sections of this specification is not implied.

1.  $\theta_{JA}$  is measured with the component mounted on a low effective thermal conductivity test board in free air. See Tech Brief TB379 for details.

**DC Electrical Specifications (Test conditions @ 25°C)**

PARAMETER	SYMBOL	TEST CONDITIONS	MIN	TYP	MAX	UNITS
Power Supply Current	$I_{CCOP}$	$V_{CC} = 3.6V$ , CLK Frequency = 44MHz	-	170	TBD	mA
Standby Power Supply Current	$I_{CCSB}$	$V_{CC} = \text{Max}$ , Outputs Not Loaded	-	3	TBD	mA
Input Leakage Current	$I_I$	$V_{CC} = \text{Max}$ , Input = 0V or $V_{CC}$	-	100	TBD	nA
Output Leakage Current	$I_O$	$V_{CC} = \text{Max}$ , Input = 0V or $V_{CC}$	-	300	TBD	nA
Logical One Input Voltage	$V_{IH}$	$V_{CC} = \text{Max}$ , Min	$0.7V_{CC}$	-	-	V
Logical Zero Input Voltage	$V_{IL}$	$V_{CC} = \text{Min}$ , Max	-	-	$V_{CC} \cdot 0.3$	V
Logical One Output Voltage	$V_{OH}$	$I_{OH} = -1mA$ , $V_{CC} = \text{Min}$	$V_{CC} - 0.2$	2.6	-	V
Logical Zero Output Voltage	$V_{OL}$	$I_{OL} = 2mA$ , $V_{CC} = \text{Min}$	-	0.05	0.2	V
Input Capacitance	$C_{IN}$	CLK Frequency = 1MHz. All measurements referenced to GND. $T_A = 25^\circ C$	-	5	10	pF
Output Capacitance	$C_{OUT}$	CLK Frequency 1MHz. All measurements referenced to GND. $T_A = 25^\circ C$	-	5	10	pF

NOTE: All values in this table have not been measured and are only estimates of the performance at this time.

**AC Electrical Specifications**

PARAMETER	SYMBOL	MIN	TYP	MAX	UNITS
<b>CLOCK SIGNAL TIMING</b>					
OSC Clock Period (Typ. 44MHz)	$t_{CYC}$	22.5	20.8	200	ns
High Period	$t_{H1}$	10	10.4	-	ns
Low Period	$t_{L1}$	10	10.4	-	ns
Full Scale Input Voltage ( $V_{P-P}$ )		TBD	TBD	4	V
<b>EXTERNAL MEMORY READ INTERFACE</b>					
MOE-Setup Time from RAMCS_	$t_{S1}$	0	-	-	ns
MOE_Setup Time from MA (17..0)	$t_{S2}$	0	-	-	ns
MA (17..1) Hold Time from MOE_ Rising Edge	$t_{H1}$	20	-	-	ns
RAMCS_ Hold from MOE_ Rising Edge	$t_{H2}$	20	-	-	ns
MD (15..0) Enable from MOE_ Falling	$t_{E1}$	5	-	-	ns
MO (15..0) Disable from MOE_ Rising Edge	$t_{D1}$	-	-	100	ns
<b>EXTERNAL MEMORY WRITE INTERFACE</b>					
MA (17..0) Setup to MWE_ Falling Edge	$t_{S3}$	0	0	0	ns
RAMCS_ Setup to MWE	$t_{S4}$	0	-	-	ns
MA (17..0) Hold from MWE_ Rising Edge	$t_{H3}$	15	-	-	ns
RAMCS_ Hold from MWE_ Rising Edge	$t_{H4}$	15	-	-	ns
MD (15..0) Setup to MWE_ Rising Edge	$t_{S5}$	40	-	-	ns
MD (15..0) Hold from MWE_ Rising Edge	$t_{H5}$	15	-	-	ns

AC Electrical Specifications (Continued)

PARAMETER	SYMBOL	MIN	TYP	MAX	UNITS
<b>SYNTHESIZER</b>					
SYNTHCLK(PK1) Period	$t_{CYC}$	90	-	4,000	ns
SYNTHCLK(PK1) Width Hi	$t_{H1}$	$t_{CYC}/2 - 10$	-	$t_{CYC}/2 + 10$	ns
SYNTHCLK(PK1) Width Lo	$t_{L1}$	$t_{CYC}/2 - 10$	-	$t_{CYC}/2 + 10$	ns
SYNTHDATA(PK2) Hold Time from Falling Edge of SYNTHCLK(PK1)	$t_{D2}$	0	-	-	ns
SYNTHCLK(PK1) Falling Edge to SYNLE Inactive	$t_{D3}$	35	-	-	ns
<b>SYSTEM INTERFACE - PCI TIMING</b>					
Cycle Time, HPCLK	$t_{CYC}$	30	-	-	ns
Pulse Duration, HPCLK High	$t_H$	11	-	-	ns
Pulse Duration, HPCLK Low	$t_L$	11	-	-	ns
Slew Rate, HPCLK	$t_S$	1	-	4	V/ns
Propogation Delay Time, HPCLK to Signal Valid Delay Time	$t_V$	-	-	11	ns
Propogation Delay Time, HPCLK to Signal Invalid Delay Time	$t_{INV}$	2	-	-	ns
Enable Time, High Impedance to Active Delay Time from HPCLK	$t_{EN}$	2	-	-	ns
Disable Time, Active to High Impedance Delay Time from HPCLK	$t_{DIS}$	-	-	28	ns
Setup Time Before HPCLK Valid	$t_S$	7	-	-	ns
Hold Time After HPCLK High	$t_H$	0	-	-	ns
<b>BASEBAND SIGNALS</b>					
Full Scale Input Voltage ( $V_{p-p}$ )		0.25	0.50	1.0	V
Input Bandwidth (-0.5dB)		-	20	-	MHz
Input Capacitance		-	5	-	pF
Input Impedance (DC)		5	-	-	k $\Omega$
FS (Sampling Frequency)		-	-	22	MHz

Waveforms

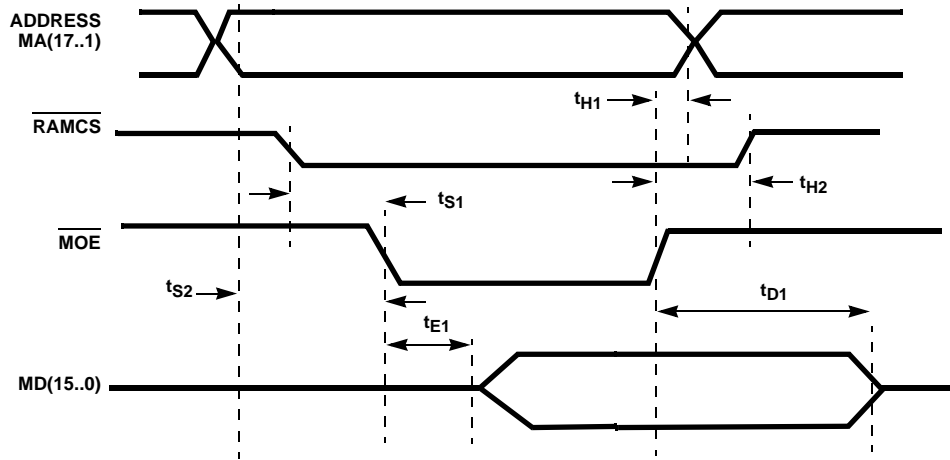

FIGURE 1. MAC EXTERNAL MEMORY READ TIMING

Waveforms (Continued)

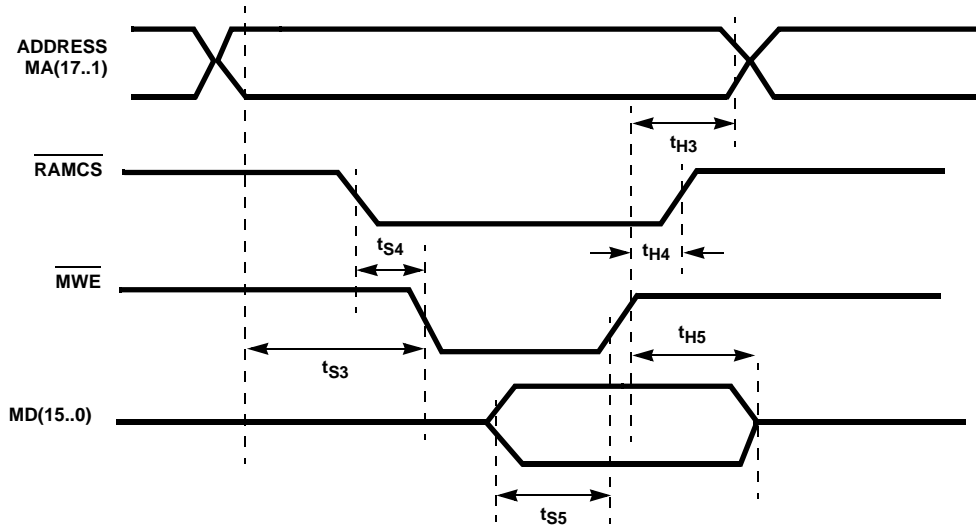

FIGURE 2. MAC EXTERNAL MEMORY WRITE TIMING

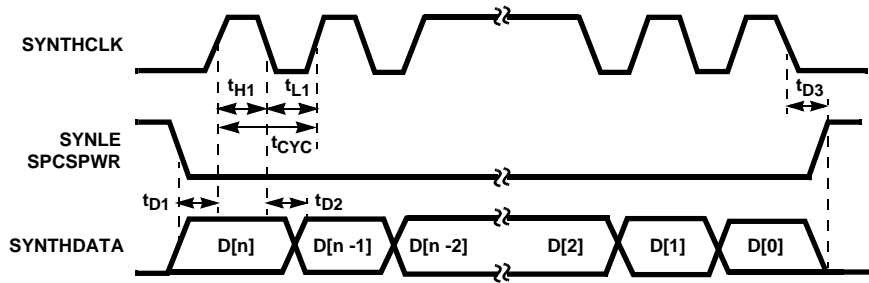

FIGURE 3. SYNTHESIZER

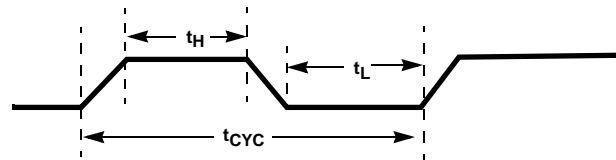

FIGURE 4. HPCLK TIMING WAVEFORM

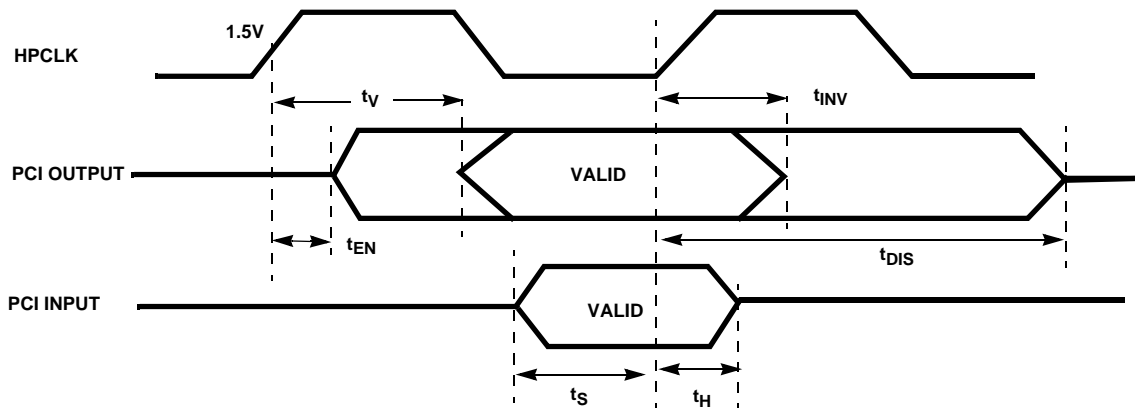

FIGURE 5. PCI BUS TIMING WAVEFORMS

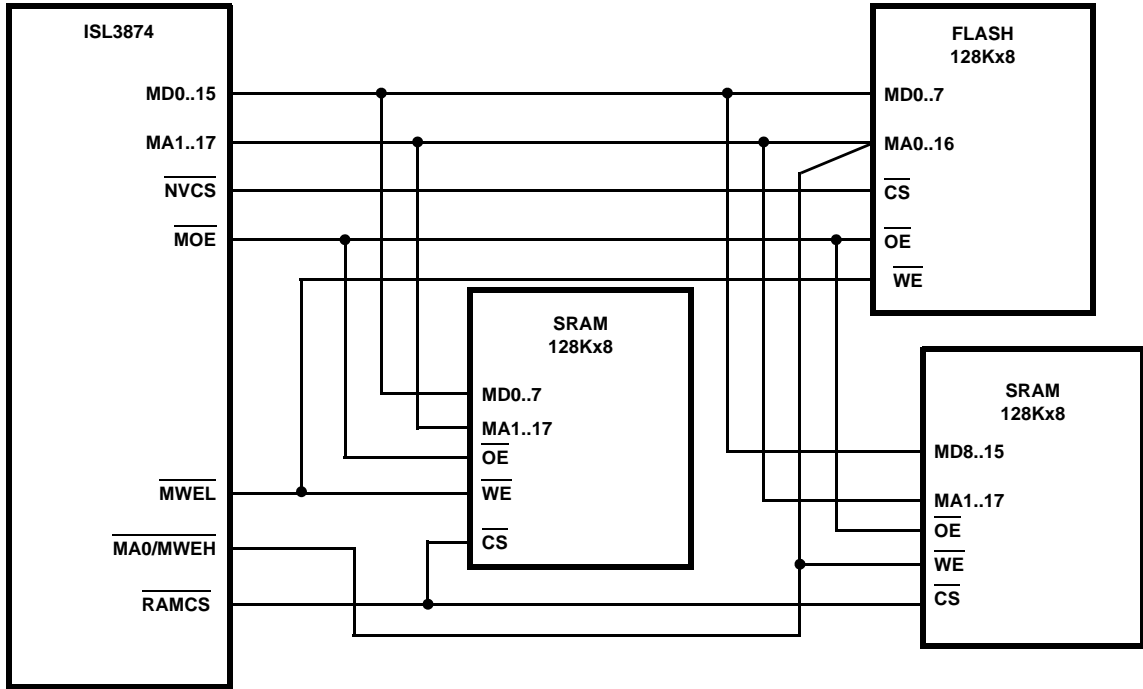

FIGURE 6. 8 BIT MEMORY INTERFACE

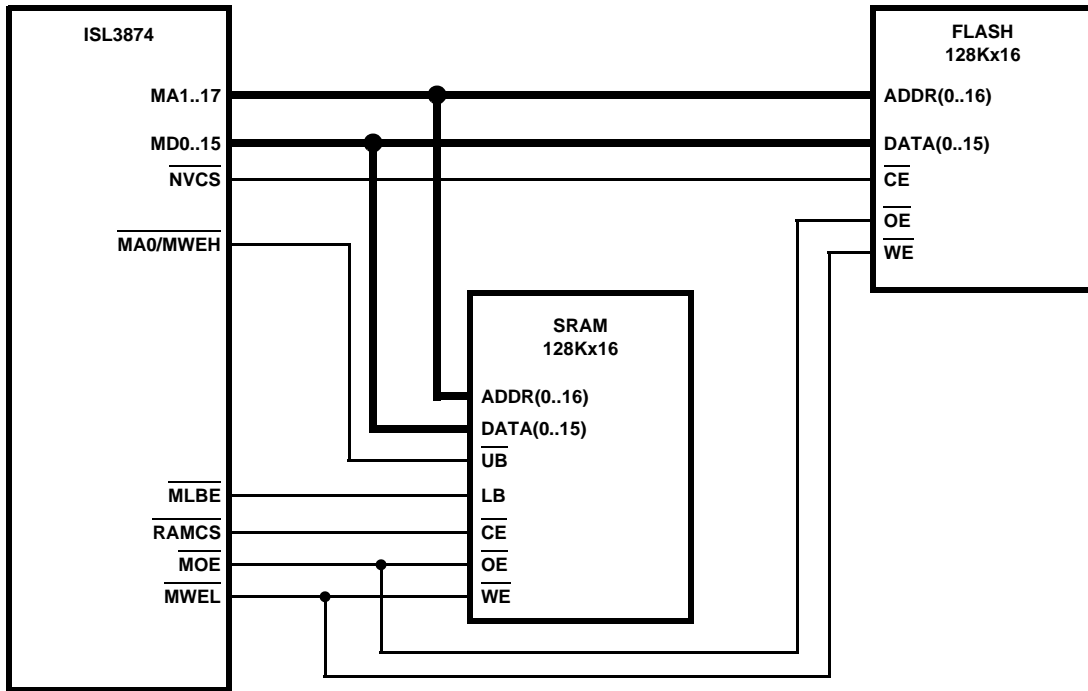

FIGURE 7. 16-BIT MEMORY INTERFACE

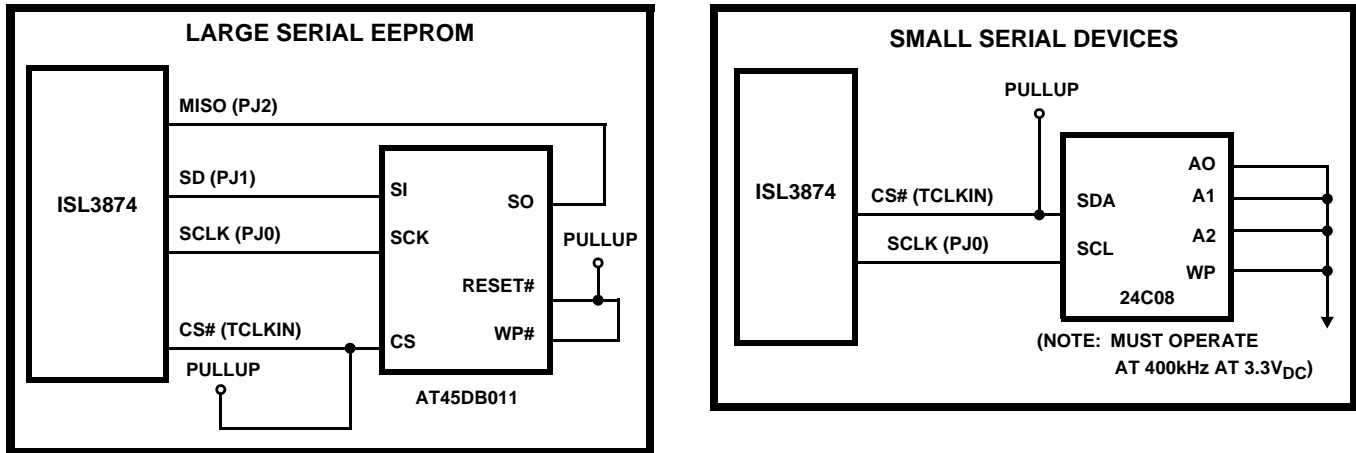

FIGURE 8. SERIAL EEPROM MEMORY INTERFACE

### External Memory Interface

The ISL3874 provides separate external chip selects for code space and data storage space. Code space is accessible as data space through an overlay mechanism, except for an internal ROM. Refer to Figures 6, 7 and 8 for ISL3874 memory configuration detail examples.

The maximum possible memory space size is 4Mbytes. Most of the data store space is reserved for storage of received and transmitted data, with some areas reserved for use by firmware. However, a portion of the data store may be allocated as code store. This permits higher speed instruction execution, by using fast RAMs, than is possible from Flash memories. The maximum size of this overlay is the full code space address range, 128kbytes, and is allocated in independent sections of 16KBytes each, on 16kbyte boundaries, ranging from the highest address of the actual physical memory space and extending down.

Mapping code execution to RAM requires the RAM to have code written into it. Typically, this is done by placing code in a non-volatile memory such as a Flash in the code space. At initialization, the code in the non-volatile memory transfers itself to RAM, maps the appropriate blocks of the code space to the RAM, and then branches to begin execution from RAM. This allows low cost, slow Flash devices to hold an entire code image, which can be executed much faster from RAM. If code is not placed in an external non-volatile memory as described here, it must be transferred to the RAM via the Host Interface.

Slow memories are not dynamically sensed. Following reset, the instruction clock operates with a slower cycle while the Flash is copied to RAM. Once code has been copied from Flash to RAM, execution transfers to RAM and the clock is raised to the normal operating frequency.

As mentioned above, it is feasible to operate without a code image in a non-volatile memory. In such a system, the firmware must be downloaded to RAM through the host interface before operation can commence.

The external SRAM memory must be organized in a 16-bit width to provide adequate performance to implement the 802.11 protocol at 11Mb/s rates. Systems designed for lower performance applications may be able to use 8-bit wide memory.

The minimum external memory is 128kbytes of SRAM, organized 8 or 16 bits wide. Typical applications, including 802.11 station designs, use 256kbytes organized 128K x 16. An access point application could make use of the full address space of the device with 4Mbytes organized a 2M x 16.

The ISL3874 supports 8 or 16-bit code space, and 8 or 16-bit data space. Code space is typically populated with the least expensive Flash memory available, usually an 8-bit device. Data space is usually populated with high-speed RAMs configured as a 16-bit space. This mixing of 8/16 bit spaces is fully supported, and may be done in any combination desired for code and data space.

The ISL3874 supports direct control of single chip 16-bit wide SRAMs with high/low byte enables, as well as direct control of a 16-bit space constructed from 8-bit wide SRAMs. The type of memory configuration is specified via the appropriate MD pin, sensed when the ISL3874 is reset.

ISL3874 pin  $\overline{\text{MA0/MWEH}}$  functions as Address 0 for 8-bit access, (such as Flash) as MWEH (High Byte Write Enable) when two x8 memories are configured as a single x16 space, and as the upper Byte Enable when a single x16 memory is used. No external logic is required to generate the required signals for both types of memory configurations, even when both exist together; all that is required is for the ISL3874 code to configure the ISL3874 memory controller to generate the proper signals for the particular address space being accessed.

For 8-bit spaces, the ISL3874 dynamically configures pin  $\overline{\text{MA0/MWEH}}$  cycle-by-cycle as the address LSB.

$\overline{\text{MWEL}}/\overline{\text{MWE}}$  is the only write control, and MOE is the read output enable.

For 16-bit spaces constructed from 8-bit memories, the ISL3874 dynamically configures pin  $\overline{\text{MA0}}/\overline{\text{MWEH}}$  cycle-by-cycle as the high byte write enable,  $\overline{\text{MWEL}}$  as the low write enable signal, and MOE as the read output enable.

For 16-bit spaces constructed from single-chip x16 memories (such as SRAMs), the ISL3874 dynamically configures pin  $\overline{\text{MA0}}/\overline{\text{MWEH}}$  cycle-by-cycle as the upper byte enable. Pin  $\overline{\text{MLBE}}$  is connected as the low byte enable,  $\overline{\text{MWEL}}/\overline{\text{MWE}}$  is the write control, and MOE is the read output enable.

These memory implementations require no external logic. The memory spaces may each be constructed from any type of memory desired. The only restriction is that a single memory space must be constructed from the same type of memory; for example, data space may not use both x8 and x16 memories, it must be all x8, or all x16. This restriction does not apply across memory spaces; e.g., code space may use a x8 memory and data space a single x16 memory, or code space two x8 memories and data space a single x8 memory.

### Serial EEPROM Memory Interface

The ISL3874 contains a small on-ship ROM firmware which was added to allow the CIS or CIS plus firmware image to be transferred from a off-chip serial nonvolatile memory device to RAM after a system reset. This allows a system configuration without a parallel Flash device. The operating frequency for the 24C08 Serial EEPROM must be 400kHz with an operating voltage of 3.3V. Refer to Figure 8 for additional details on configuring the serial memory to the ISL3874.

The Power On Reset Configuration Section in this document provides additional details on memory selection and control after a reset condition.

### PC Card Interface

The PCI Host Interface allows access to the ISL3874 memory and host registers using PCI memory read or write transactions.

The host interface supports Target Mode operation transferring double words. Direct memory access to the ISL3874 memory space using Aux port transfers is supported in Target Mode. BAP transfers operate in Target Mode in a similar manner to how they worked on the HFA3842 and thus allow quick porting of base functionality HFA3842 driver code to this part.

Most of the host side registers have been preserved except where functionality is no longer needed. For example, the attribute FCR registers are not implemented since attribute space does not exist for the PCI interface. Only memory

space is implemented in this part so PCI I/O read or write operations are not defined.

### PCI Interface Configuration

The PCI core has two sets of configuration registers. One set is read-only and configured to default values or set up by ISL3874 firmware on reset. This set is used by the host to determine what type of card this is, and what drivers need to be loaded. The other set is the host configuration registers. These are written by the host to configure various options and responses of the PCI card.

During reset the core's strapping options cause one of two scenarios to occur for loading the read-only PCI configuration registers. If the part is set to power up and run then the ISL3874 firmware is responsible for fetching values from its memory space and loading them into the proper registers. Note that the interface will be unable to respond to host commands including configuration commands until these registers have been loaded.

If the part is set to power up and go idle then default values are loaded into the read-only registers so that the PCI interface can be initialized by the host. This mode is most likely the case when downloading firmware code via the Aux port. Since there is no existing firmware to control the part the default values allow the host to configure the rest of the interface enough to be able to download code into the memory space of the ISL3874.

The read-only registers set the device id, vendor id, class code, revision id, header type, subsystem id, subsystem vendor id, maximum latency, minimum grant, and the interrupt pin. These registers are all 16 bits wide and are loaded by the DBus. They must be loaded in the following order: {max\_lat, min\_gnt}, {class\_code[23:16], header}, class\_code[15:0], {int\_pin, rev\_id}, subsys\_id, subsys\_vendor\_id, device\_id, vendor\_id.

The default values are:

- device\_id 0x3873
- vendor\_id 0x1260 // Intersil PCI SIG vendor id.
- class\_code 0x02\_8000
- subsys\_id 0x0000
- subsys\_vendor\_id 0x1260 // Intersil PCI SIG vendor id.
- rev\_id 0x01
- header 0x00
- max\_lat 0x00
- min\_gnt 0x00
- int\_pin 0x01 // Int A

On reset or power up the PCI interface has several host configuration registers that must be written by the host before normal target memory read/write transactions can be used. Target operations are enabled once the Memory Base Address and the Command registers have been written.

These are the minimum set of registers required for the card to respond to a target operation.

The Memory Base Address register is used to set the starting address range this device will respond to. The maximum address space for this chip is 4K. The Command register enables specific features of the PCI host interface. The Memory Access Enable bit must be set to allow any read/write operations. Further information about the PCI configuration registers can be found in the PCI 2.1 Interface spec.

### **Target Mode Operation**

This mode is the default or base mode of communicating with the ISL3874 processor. After the host configures the PCI interface itself, PCI memory read and write transactions are used to initialize the processor and to send it commands. These transactions access host side register addresses in much the same way as the HFA3842 did. Host registers have had their address DWORD aligned (shifted left by one) from the register map used by the HFA3842. This allows ordinary double word accesses to take place on any given host register. Host register addresses are 8 bits wide and wrap at 0xFF in memory space up to the maximum address space. Each register provides up to 16 bits of valid data depending on the PCI read or write system call request length. PCI requests for greater than word length (16 bits) will have the upper bits zeroed.

### **PCI Specific Implementation**

The ISL3874 host side memory space is not intended to be written in a sequential manner so burst operations are not supported.

Only memory read, memory write, and configuration cycles are supported in target mode. Fast block transfers with the least amount of host overhead can be implemented in Master mode, however, throughput will be limited by available Mbus bandwidth. BAP transfers are supported in Target mode and should be faster than equivalent PCMCIA BAP transactions. This allows a port of the existing driver from the PCMCIA part to PCI with minimal changes.

The ISL3874 is a single function device so only one interrupt, HINTA, is used. An interrupt is generated whenever one of the interrupt sources in the ISR goes active and the corresponding bit in the IMR is enabled. The interrupt pin, HINTA, generates an active low level when requesting an interrupt.

### **Reset**

There are two reset pins for this part. The first, GRESET is a hardware reset pin used to reset the entire part on power up. The second reset is the HRESET. This is intended to reset only the PCI interface section.

A soft reset is available which does not reset any of the PCI core read-only configuration registers. This soft reset is accomplished in the same manner as the HFA3842 by writing a one to COR[7]. Note this register has been moved from its previous location. It now resides at location 0x4C.

Only bit 7 (Soft Reset) is implemented for this register. The HCR and COR registers are the only registers that can be written during soft reset. The HCR can be written to override the default Mbus strapping options and COR[7] is reset to bring the part out of soft reset.

LOCK# is not implemented. We do not have atomic accesses and thus have no need to support this. Further, it is not implemented in the mini-PCI spec.

### **Normal Operating Modes**

Target mode has three different types of accesses. The biggest difference between them as far as the host is concerned is the amount of time it takes to complete the accesses. The three types are hardware registers, memory mapped registers and BAP data registers.

Hardware registers complete their access in one M clock cycle, which at normal M clock speeds means the PCI read will complete without a retry.

Memory mapped read cycles will almost always require at least one retry depending on M clock speed and how soon the ISL3874 memory controller grants the memory request.

BAP read cycles can fall into either case depending on whether or not a pre-read completes prior to the host requesting another transfer.

The PCI interface supports one level of posted writes. That is, the first write cycle will be accepted and the PCI interface will complete the transaction immediately. If another write occurs before the first write has completed internally, it will not be accepted and the PCI bus will have to retry the write at a later time.

### **PC Card Physical Interface**

The Host interface is compatible to the Mini-PCI Specification. Further details on programming and controlling the PCI interface can be found in the programmers manual for the ISL3874. The following describes specific features of various pins:

**HAD(0-31)** - PCI Card Address and Data Input, Bits 0 to 31. These signals make up the multiplexed PCI address and data bus on the primary interface. During the address phase of a primary bus PCI cycle, HAD31-HAD0 contain a 32-bit address or other destination information. During the data phase, HAD31-HAD0 contain data.

**HBE2** - PCI bus commands and byte enables. HBE2 applies to byte 2 (HAD23-HAD16).

**HBE1** - PCI bus commands and byte enables. HBE1 applies to byte 1 (HAD15-HAD8).

**HBE0** - PCI bus commands and byte enables. HBE0 applies to byte 0 (HAD7-HAD0).

**HIDSEL** - Initialization device select. HIDSEL selects the ISL3874 during configuration space accesses. HIDSEL can



be connected to one of the upper 24 PCI address lines on the PCI bus.

**HRESET** - PCI Card reset signal. This reset signal only resets the PCI core.

**HFRAME** - PCI Card FRAME cycle signal. FRAME is driven by the initiator of a bus cycle. FRAME is asserted to indicate that a bus transaction is beginning, and data transfers continue while this signal is asserted. When FRAME is deasserted, the PCI bus transaction is in the final data phase.

**HIRDY** - PCI initiator ready. HIRDY indicates the PCI bus initiators ability to complete the current data phase of the transaction. A data phase is completed on a rising edge of PCLK where both HIRDY and HTRDY are asserted. Until HIRDY and HTRDY are both sampled asserted, wait states are inserted.

**HPAR** - PCI bus parity. The ISL3874 calculates even parity across the buses HAD(31-0) and HBE(3-0).

**HTRDY** - PCI target ready. HTRDY indicates the primary bus targets ability to complete the current data phase of the transaction. A data phase is completed on a rising edge of PCLK when both HIRDY and HTRDY are asserted. Until both HIRDY and HTRDY are asserted, wait states are inserted.

**HDEVSEL** - PCI device select. The ISL3874 asserts HDEVSEL to claim a PCI cycle as the target device. As a PCI initiator on the bus, the ISL3874 monitors HDEVSEL until a target responds. If no target responds before a timeout occurs, the ISL3874 terminates the cycle with an initiator abort.

**HSTOP** - PCI cycle stop signal. HSTOP is driven by a PCI target to request the initiator to stop the current PCI bus transaction. HSTOP is used for target disconnects and is commonly asserted by target devices that do not support burst data transfers.

**HPERR** - PCI parity error indicator. HPERR is driven by a PCI device to indicate that the calculated parity does not match HPAR when HPERR is enabled.

**HSERR** - PCI system error. HSERR is an output that is pulsed from the ISL3874 when enabled through the command register indicating a system error has occurred. The ISL3874 need not be the target of the PCI cycle to assert this signal. When HSERR is enabled in the control register, this signal also pulses, indicating that an address parity error has occurred on a CardBus interface.

**HREQ** - PCI bus request. HREQ is asserted by the ISL3874 to request access to the PCI bus as an initiator.

**HGNT** - PCI bus grant. HGNT is driven by the PCI bus arbiter to grant the ISL3874 access to the PCI bus after the current data transaction has completed. HGNT may or may

not follow a PCI bus request, depending on the PCI bus parking algorithm.

**HPCLK** - HPCLK provides timing for all transactions on the PCI bus. All PCI signals are sampled at the rising edge of PCLK.

**HPME** - Power Management Event Output. HPME provides output for PME signals.

### **Register Interface**

The logical view of the ISL3874 from the host is a block of 32 word wide registers. These appear in IO space starting at the base address determined by the socket controller. There are three types of registers.

#### **HARDWARE REGISTERS (HW)**

- 1 to 1 correspondence between addresses and registers.
- No memory arbitration delay, data transfer directly to/from registers.
- AUX base and offset are write-only, to set up access through AUX data port.
- Note: All register cycles, including hardware registers, incur a short wait state on the PC Card bus to insure the host cycle is synchronized with the ISL3874's internal MCLK.

#### **MEMORY MAPPED REGISTERS IN DATA RAM (MM)**

- 1 to 1 correspondence.
- Requires memory arbitration, since registers are actually locations in ISL3874 memory.
- Attribute memory access is mapped into RAM as Base-address + 0x400.
- AUX port provides host access to any location in ISL3874 RAM (reserved).

#### **BUFFER ACCESS PATH (BAP)**

- No 1 to 1 correspondence between register address and memory address (due to indirect access through buffer address pointer registers).
- Auto increment of pointer registers after each access.
- Require memory arbitration since buffers are located in ISL3874 memory.
- Buffer access may incur additional delay for Hardware Buffer Chaining.

### **Buffer Access Paths**

The ISL3874 has two independent buffer access paths, which permits concurrent read and write transfers. The firmware provides dynamic memory allocation between Transmit and Receive, allowing efficient memory utilization. On-the-fly allocation of (128-byte) memory blocks as needed for reception wastes minimal space when receiving fragments. The ISL3874 hides management of free memory from the driver, and allows fast response and minimum data copying for low latency. The firmware provides direct access to TX and RX buffers based on Frame ID (FID). This



facilitates Power Management queuing, and allows dynamic fragmentation and defragmentation by controller. Simple Allocate/Deallocate commands insure low host CPU overhead for memory management.

Hardware buffer chaining provides high performance while reading and writing buffers. Data is transferred between the host driver and the ISL3874 by writing or reading a single register location (The Buffer Access Path, or BAP). Each access increments the address in the buffer memory. Internally, the firmware allocates blocks of memory as needed to provide the requested buffer size. These blocks may not be contiguous, but the firmware builds a linked list of pointers between them. When the host driver is transferring data through a buffer access path and reaches the end of a physical memory block, hardware in the host interface follows the linked list so that the buffer access path points to the beginning of the next memory block. This process is completely transparent to the host driver, which simply writes or reads all buffer data to the same register. If the host driver attempts to access beyond the end of the allocated buffer, subsequent writes are ignored, and reads will be undefined.

### Power Sequencing

The ISL3874 provides a number of firmware controlled port pins that are used for controlling the power sequencing and other functions in the front end components of the radio.

Packet transmission requires precise control of the radio. Ideally, energy at the antenna ceases after the last symbol of information has been transmitted. Additionally, the transmit/receive switch must be controlled properly to protect the receiver. It is also important to apply appropriate modulation to the PA while it's active.

Signaling sequences for the beginning and end of normal transmissions are illustrated in Figure 9. Table 10 lists applicable delays associated with these control signals.

A transmission begins with PE2 as shown in Figure 9. Next, the transmit/receive switch is configured for transmission via the differential pair TR\_SW and TR\_SW\_BAR. This is followed by a transmit enable (TX\_ENABLE) to the Baseband processor inside the ISL3874. This enable activates the transmit state machine in the BBP. Lastly, PA\_PE activates the PA. Delays for these signals related to the initiation of transmission are referenced to PE2.

Immediately after the final data bit has been clocked out of the MAC the Baseband processor is disabled. The MAC then waits for a control signal (TX\_READY) from the Baseband processor to go inactive, signaling that the BBP has modulated the final information-rich symbol. It then immediately de-asserts PA\_PE followed by placing the transmit/receive switch in the receive position and ending with PE2 going high. Delays for these signals related to the termination of transmission are referenced to the rising edge of PE2.

TABLE 10. TRANSMIT CONTROL TIMING SPECIFICATIONS

PARAMETER	SYMBOL	DELAY	TOLERANCE	UNITS
TX_PE to PE2	$t_{D1}$	.1	$\pm 0.1$	$\mu\text{s}$
TX_PE to PA_PE	$t_{D2}$	1	$\pm 0.1$	$\mu\text{s}$
TX_PE to TR_SW	$t_{D3}$	3	$\pm 0.1$	$\mu\text{s}$
TR_SW to TX_PE	$t_{D4}$	3	$\pm 0.1$	$\mu\text{s}$
PA_PE to TR_SW	$t_{D5}$	1	$\pm 0.1$	$\mu\text{s}$
PE2 to TX_PE	$t_{D6}$	.1	$\pm 0.1$	$\mu\text{s}$

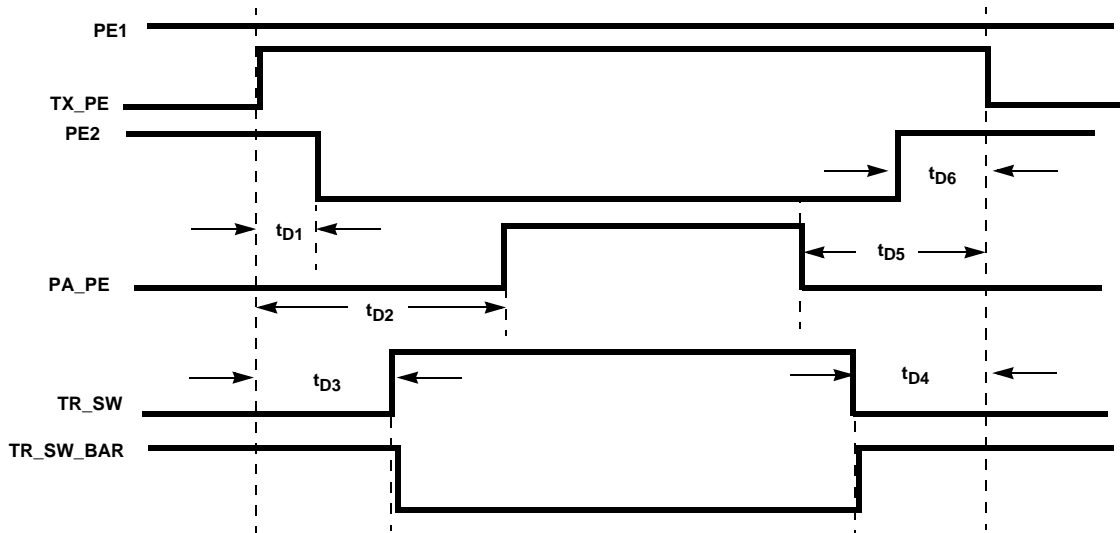

FIGURE 9. TRANSMIT CONTROL SIGNAL SEQUENCING

PE1 and PE2 encoding details are found in Table 11.

Note that during normal receive and transmit operation that PE1 is static and PE2 toggles for receive and transmit states.

**TABLE 11. POWER ENABLE STATES**

	PE1	PE2	PLL_PE
Power Down State	0	0	1
Receive State	1	1	1
Transmit State	1	0	1
PLL Active State	0	1	1
PLL Disable State	X	X	0

NOTE: PLL\_PE is controlled via the serial interface, and can be used to disable the internal synthesizer, the actual synthesizer control is an AND function of PLL\_PE, and a result of the OR function of PE1 and PE2. PE1 and PE2 will directly control the power enable functionality of the LO buffer(s)/phase shifter.

## Master Clock

### Prescaler

The ISL3874 contains a clock prescaler to provide flexibility in the choice of clock input frequencies. For 11Mb/s operation, the internal master clock, MCLK, must be between 11MHz and 16MHz. The clock generator itself requires an input from the prescaler that is at least twice the desired MCLK frequency. Thus the lowest oscillator frequency that can be used for an 11MHz MCLK is 22MHz. The prescaler can divide by integers and 1/2 steps (i.e., 1, 1.5, 2, 2.5). Another way to look at it is that the divisor ratio between the external clock source and the internal MCLK may be integers between 2 and 14.

Typically, the 44MHz baseband clock is used as the input, and the prescaler is set to divide by 2. Contact the factory for further details on setting the clock prescaler register in the ISL3874.

### Low-Frequency Crystal

The ISL3874 controller can accept the same clock signal as the PHY baseband processor (typically 44MHz), thereby avoiding the need for a separate, MAC-specific oscillator. The low-frequency oscillator is intended for use with a 32.768kHz, tuning-fork type watch crystal to permit accurate timekeeping with very low power consumption during sleep state.

If a 32.768kHz crystal is connected, the resulting LF clock is supplied to an interval timer to permit measuring sleep intervals as well as providing a programmable wake-up time. In addition, the clock generator can operate either from BBP\_CLK or (very slowly) from the LF clock. Glitch-free switching between these two clock sources, under firmware control, is provided by two, non-architectural Strobe functions ("FAST" and "SLOW"). In addition, during hardware reset, the clock generator source is set to the LF clock if no edges are detected on CLKIN for two cycles of the LF clock (roughly 61

microseconds). This allows proper initialization with omission of either clock source, since without the LF crystal attached there will not be cycles of the LF clock to activate the detection circuit. The ability to initialize the ISL3874 using the LF oscillator to generate MCLK allows the high-frequency (PHY) oscillator to be powered down during sleep state. If this is done, firmware can turn on power to the PHY oscillator upon wake-up, and use the interval timer to measure the start-up and stabilization period before switching to use CLKIN.

### Clock Generator

The ISL3874 operates with BBP\_CLK frequency of 44MHz. The MCLK prescaler generates MCLK (and QCLK) from the external clock provided at the BBP\_CLK input, or from the output of the LF oscillator. The MCLK prescaler divides the selected input clock by any integer value between 2 and 16, inclusive.

The MCLK prescaler is set to divide by 16 at hardware reset to allow initialization firmware to be executed from slow memory devices at any BBP\_CLK frequency. The MCLK prescaler generates glitch free output when the divisor is changed. This allows firmware to change the MCLK frequency during operation, which is especially useful to selectively reduce operating speed, thereby conserving power, when full speed processing is not required.

### Power On Reset Configuration

Power On Reset is issued to the ISL3874 with the GRESET pin or via the soft reset bit, SRESET, in the Configuration Option Register (COR, bit 7).

The MD[15:8] pin values are sampled during GRESET. These pins have internal 50K pull-up and pull-down resistors. External resistors (typically 10kΩ) are necessary to change the internal default setting.

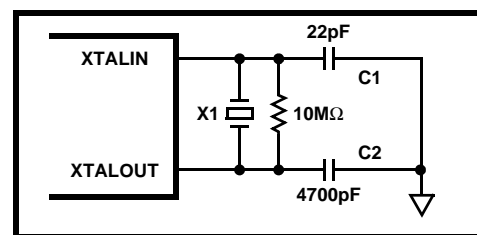

**FIGURE 10. 32.768kHz CRYSTAL**

MD[11], IDLE, has no equivalent functionality in any control register. When asserted at reset, it will inhibit firmware execution. This is used to allow the initial download of firmware in "Genesis Mode". See the Hardware Reference Manual for more details. The latch is cleared when the Software Reset, SRESET, COR(7) is active.

HRESET is connected to the PCI reset and will only reset the PCI core. GRESET can be driven by HRESET if MD13 is pulled high.

Table 12 summarizes the effect per pin. Table 13 provides the MD15 and MD14 bit values required to allow the ISL3874 to use the external Serial EEPROM bootup option.

**Baseband Processor**

The Baseband Processor operation is controlled by the ISL3874 firmware. Detailed information on programming the Baseband Processor can be obtain by contacting the factory. Internal registers and their function are provided as reference material in this data sheet.

**BBP Packet Reception**

The receive demodulator scrutinizes I and Q for packet activity. When a packet arrives at a valid signal level the demodulator acquires and tracks the incoming signal. It then sifts through the demodulator data for the Start Frame Delimiter (SFD). After SFD is detected, The BBP picks off the needed header fields from the real-time demodulated bitstream.

Assuming all is well with the header, the BBP decodes the signal field in the header and switches to the appropriate data rate. If the signal field is not recognized, or the CRC16

is in error, the demodulator will return to acquisition mode looking for another packet. If all is well with the header, and after the demodulator has switched to the appropriate data rate, then the demodulator will continue to provide data to the MAC in the ISL3874 indefinitely. The MAC terminates reception at the end of a packet.

**RX I/Q A/D Interface**

The PRISM baseband processor chip (ISL3874) includes two 6-bit Analog to Digital converters (A/Ds) that sample the balanced differential analog input from the IF down converter device (HFA3783). The I/Q A/D clock, samples at twice the chip rate with a nominal sampling rate of 22MHz.

The interface specifications for the I and Q A/Ds are listed in Table 14. The ISL3874 is designed to be DC coupled to the HFA3783.

The voltages applied to pin 16,  $V_{REF}$  and pin 21,  $I_{REF}$  set the references for the internal I and Q A/D converters. In addition, For a nominal I/Q input of 400mV<sub>P-P</sub>, the suggested  $V_{REF}$  voltage is 1.2V.

TABLE 12. INITIALIZATION STRAPPING OPTIONS ON MBUS DATA PINS

BITS	NAME	DEFAULT	FUNCTION
15:14	NVtype[1:0]	3	Indicates type of serial NV memory to be read by initialization firmware in on-chip ROM. Up to 8 NV device types can be encoded with (Strldle or NVtype). If Strldle = 0, NV memory holds a firmware image, and NVtype identifies 1 of 4 "large" (. = 128kb) types. If Strldle = 1, the NV memory just holds the CIS, and NVtype identifies 1 of 4 "small" (< = 8kb) types.
13	PCIGRst	0	Connects GRESET to HRESET internally when = 1.
12	4Wire	0	Use 4-wire interface to SRAM (CS-, OE-, WEH-, WEL-) as on HFA3841 and appropriate when using the HFA3842 with x8 SRAMs. When = 0 selects 5-wire interface for use with x16 SRAM (CS-, OE-, WE-, UBE-, LBE-).
11	Strldle	1	Start idle (wait for download from PC Card host interface).
10	Mem16	1	RAM and NV space at startup is x 16. When = 0 RAM and NV space at startup is x 8. If starting from off-chip NV memory this setting must indicate the width of the startup Flash Memory. During initialization, firmware can set separate widths or RAM and NV space in the Memory Control Register.
9	NVds	1	Disable mapping of off-chip control store to NV space (hence map off-chip control store to RAM space). When = 0 off-chip control store is mapped to NV memory.
8	ROMds	0	Disable on-chip control store ROM. When = 0 enable on-chip control store ROM.
7:0	Spare	0 x 00F	Not assigned.

TABLE 13. SERIAL EEPROM SELECTION

MD15	MD14	DEVICE TYPE	NOTES
0	0	AT45DB011	Large Serial Device used to transfer CIS information firmware to SRAM.
0	1	24C08 (Note 2)	Small Serial Device which contains only CIS information. MAC goes idle after loading CIS data and waits on the Host for further instructions.
1	X	None	Modes not supported in Firmware at this time. Consult factory for additional device types added.

NOTE:

- 2. The operating frequency of the serial port is 400kHz with a voltage of 3.3V.

TABLE 14. I, Q, A/D SPECIFICATIONS

PARAMETER	MIN	TYP	MAX
Full Scale Input Voltage ( $V_{P-P}$ )	0.90	1.00	1.10
Input Bandwidth (-0.5dB)	-	11MHz	-
Input Capacitance (pF)	-	2	-
Input Impedance (DC)	5k $\Omega$	-	-
$f_S$ (Sampling Frequency)	-	22MHz	-

### AGC Circuit

The AGC circuit as shown in Figure 11 is designed to adjust for signal level variations and optimize A/D performance for the I and Q inputs by maintaining the proper headroom on the 6-bit converters. There are two gain stages being controlled. At RF, the gain control is a 30dB step change. This RF gain control optimizes the receiver dynamic range when the signal level is high and maintains the noise figure of the receiver when it is needed most at low signal level. At IF, the gain control is linear and covers the bulk of the gain control range of the receiver.

The AGC loop is partially digital which allows for holding the gain fixed during a packet. The AGC sensing mechanism uses a combination of the I and Q A/D converters and the detected signal level in the IF to determine the gain settings. The A/D outputs are monitored in the ISL3874 for the desired nominal level. When it is reached, by adjusting the receiver gain, the gain control is locked for the remainder of the packet.

### RX\_AGC\_IN Interface

The signal level in the IF stage is monitored to determine when to impose the 30dB gain reduction in the RF stage. This maximizes the dynamic range of the receiver by keeping the RF stages out of saturation at high signal levels. When the IF circuits' sensor output reaches  $0.5V_{DD}$ , the ISL3874 comparator switches in the 30dB pad and also adds 30dB of gain to the IF AGC amplifier. This compensates the IF AGC and RSSI measures.

### TX I/Q DAC Interface

The transmit section outputs balanced differential analog signals from the transmit DACs to the HFA3783. These are DC coupled and digitally filtered.

### Test Port

The ISL3874 provides the capability to access a number of internal signals and/or data through the Test port, pins TEST 7:0. The test port is programmable through configuration register (CR34). Any signal on the test port can also be read from configuration register (CR50) via the serial control port. Additionally, the transmit DACs can be configured to show signals in the receiver via CR14. This allows visibility to analog like signals that would normally be very difficult to capture.

### Transmitter Description

The ISL3874 transmitter is designed as a Direct Sequence Spread Spectrum Phase Shift Keying (DSSS PSK) modulator. It can handle data rates of up to 11Mbps (refer to AC and DC specifications). The various modes of the modulator are Differential Binary Phase Shift Keying (DBPSK) for 1Mbps, Differential Quaternary Phase Shift Keying (DQPSK) for 2Mbps, and Complementary Code Keying (CCK) for 5.5Mbps and 11Mbps. These implement data rates as shown in Table 15. The major functional blocks of the transmitter include a network processor interface, DPSK modulator, high rate modulator, a data scrambler and a spreader, as shown in Figure 16. CCK is essentially a quadrature phase form of M-ARY Orthogonal Keying. A description of that modulation can be found in Chapter 5 of: "Telecommunications System Engineering", by Lindsey and Simon, Prentis Hall publishing.

The preamble is always transmitted as the DBPSK waveform while the header can be configured to be either DBPSK, or DQPSK, and data packets can be configured for DBPSK, DQPSK, or CCK. The preamble is used by the receiver to achieve initial PN synchronization while the header includes the necessary data fields of the communications protocol to establish the physical layer link. The transmitter generates the synchronization preamble and header and makes the DBPSK to DQPSK or CCK switchover, as required.

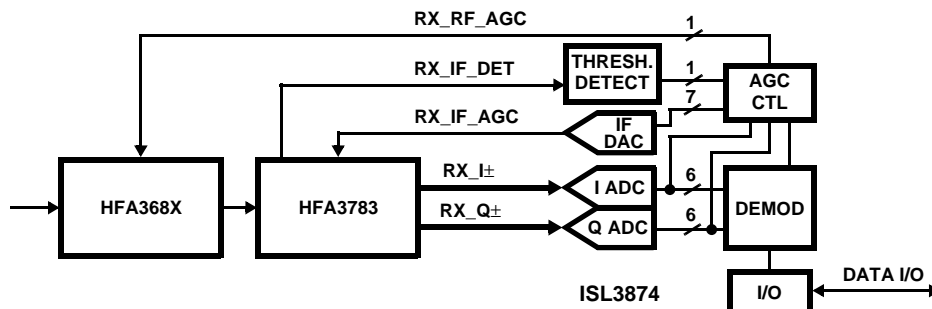

FIGURE 11. AGC CIRCUIT

For the 1 and 2Mbps modes, the transmitter accepts data from the external source, scrambles it, differentially encodes it as either DBPSK or DQPSK, and spreads it with the BPSK PN sequence. The baseband digital signals are then output to the external IF modulator.

For the CCK modes, the transmitter inputs the data and partitions it into nibbles (4 bits) or bytes (8 bits). At 5.5Mbps, it uses two of those bits to select one of 4 complex spread sequences from a table of CCK sequences and then QPSK modulates that symbol with the remaining 2 bits. Thus, there are 4 possible spread sequences to send at four possible carrier phases, but only one is sent. This sequence is then modulated on the I and Q outputs. The initial phase reference for the data portion of the packet is the phase of the last bit of the header. At 11Mbps, one byte is used as above where 6 bits are used to select one of 64 spread sequences for a symbol and the other 2 are used to QPSK modulate that symbol. Thus, the total possible number of combinations of sequence and carrier phases is 256. Of these only one is sent.

The bit rate Table 15 shows examples of the bit rates and the symbol rates and Figure 12 shows the modulation schemes.

**Header/Package Description**

The ISL3874 is designed to handle packetized Direct Sequence Spread Spectrum (DSSS) data transmissions. The ISL3874 generates its own preamble and header information. It uses two packet preamble and header configurations. The first is backwards compatible with the existing IEEE 802.11-1997 1 and 2Mbps modes and the second is the optional shortened mode which maximizes throughput at the expense of compatibility with legacy equipment.

In the long preamble mode, the device uses a synchronization preamble of 128 symbols along with a header that includes four fields. The preamble is all 1's (before entering the scrambler) plus a start frame delimiter (SFD). The actual transmitted pattern of the preamble is

TABLE 15. BIT RATE TABLE EXAMPLES FOR MCLK = 44MHz

DATA MODULATION	A/D SAMPLE CLOCK (MHz)	TX SETUP CR 5 BITS 1, 0	RX SIGNAL CR 63 BITS 7, 6	DATA RATE (Mbps)	SYMBOL RATE (MSPS)
DBPSK	22	00	00	1	1
DQPSK	22	01	01	2	1
CCK	22	10	10	5.5	1.375
CCK	22	11	11	11	1.375

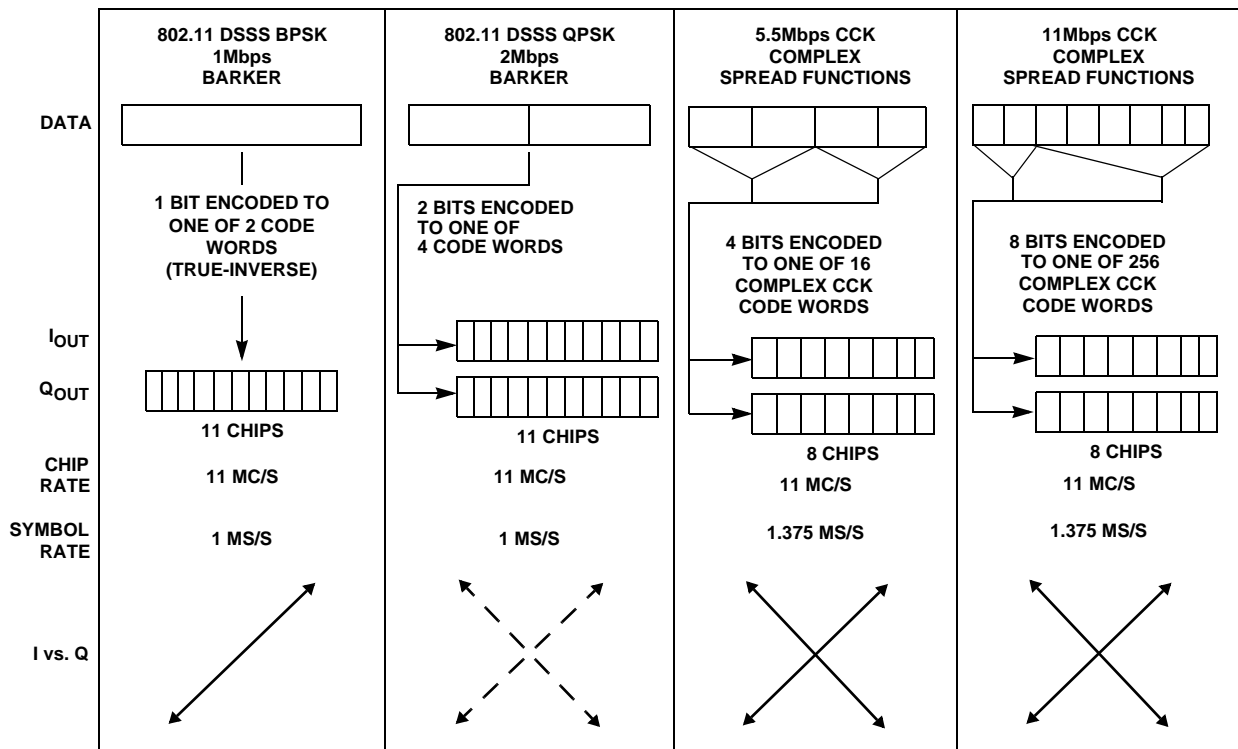

FIGURE 12. MODULATION MODES



In the short preamble mode, the modem uses a synchronization field of 56 zero symbols along with an SFD transmitted at 1Mbps. The short header is transmitted at 2Mbps. The synchronization preamble is all 0's to distinguish it from the long header mode and the short preamble SFD is the time reverse of the long preamble SFD. The duration of the short preamble and header is 96µs.

**Start Frame Delimiter (SFD) Field (16 Bits)** - This field is used to establish the link frame timing. The ISL3874 will not declare a valid data packet, even if it PN acquires, unless it detects the SFD. The ISL3874 receiver auto-detects if the packet is long or short preamble and sets SFD time-out. The timer starts counting after initialization of the de-scrambler is complete.

The four fields for the header shown in Figure 13 are:

**Signal Field (8 Bits)** - This field indicates what data rate the data packet that follows the header will be. The ISL3874 receiver looks at the signal field to determine whether it needs to switch from DBPSK demodulation into DQPSK, or CCK demodulation at the end of the preamble and header fields.

**Service Field (8 Bits)** - The MSB of this field is used to indicate the correct length when the length field value is ambiguous at 11Mbps. See IEEE STD 802.11 for definition of the other bits. Bit 2 is used by the ISL3874 to indicate that the carrier reference and the bit timing references are derived from the same oscillator (locked oscillators).

**Length Field (16 Bits)** - This field indicates the number of microseconds it will take to transmit the payload data (PSDU). The external controller (MAC) will check the length field in determining when it needs to de-assert RX\_PE.

**CCITT - CRC 16 Field (16 Bits)** - This field includes the 16-bit CCITT - CRC 16 calculation of the three header fields. This value is compared with the CCITT - CRC 16 code calculated at the receiver. The ISL3874 receiver will indicate a CCITT - CRC 16 error via CR24 bit 2 and will lower MD\_RDY and reset the receiver to the acquisition mode if there is an error.

The CRC or cyclic Redundancy Check is a CCITT CRC-16 FCS (frame check sequence). It is the ones complement of the remainder generated by the modulo 2 division of the protected bits by the polynomial:

$$x^{16} + x^{12} + x^5 + 1$$

The protected bits are processed in transmit order. All CRC calculations are made ahead of data scrambling. A shift register with two taps is used for the calculation. It is preset

to all ones and then the protected fields are shifted through the register. The output is then complemented and the residual shifted out MSB first.

The following Configuration Registers (CR) are used to program the preamble/header functions, more programming details about these registers can be found in the Control Registers section of this document:

**CR3** - Defines the short preamble length minus the SFD in symbols. The 802.11 protocol requires a setting of 56d = 38h for the optional short preamble.

**CR4** - Defines the long preamble length minus the SFD in symbols. The 802.11 protocol requires a setting of 128d = 80h for the mandatory long preamble.

**CR5 Bits 0, 1** - These bits of the register set the Signal field to indicate what modulation is to be used for the data portion of the packet.

**CR6** - The value to be used in the Service field.

**CR7 and CR8** - Defines the value of the transmit data length field. This value includes all symbols following the last header field symbol and is in microseconds required to transmit the data at the chosen data rate.

The packet consists of the preamble, header and MAC Protocol Data Unit (MPDU). The data is transmitted exactly as received from the control processor. Some dummy bits are appended to the end of the packet to ensure an orderly shutdown of the transmitter. This prevents spectrum splatter. At the end of a packet, the MAC shuts the transmitter down.

### Scrambler and Data Encoder Description

The modulator has a data scrambler that implements the scrambling algorithm specified in the IEEE 802.11 standard. This scrambler is used for the preamble, header, and data in all modes. The data scrambler is a self synchronizing circuit. It consists of a 7-bit shift register with feedback from specified taps of the register. Both transmitter and receiver use the same scrambling algorithm. The scrambler can be disabled by setting CR32 bit 2 to 1.

NOTE: Be advised that the IEEE 802.11 compliant scrambler in the ISL3874 has the property that it can lock up (stop scrambling) on random data followed by repetitive bit patterns. The probability of this happening is 1/128. The patterns that have been identified are all zeros, all ones, repeated 10s, repeated 1100s, and repeated 111000s. Any break in the repetitive pattern will restart the scrambler. To ensure that this does not cause any problem, the CCK waveform uses a ping pong differential coding scheme that breaks up repetitive 0's patterns.

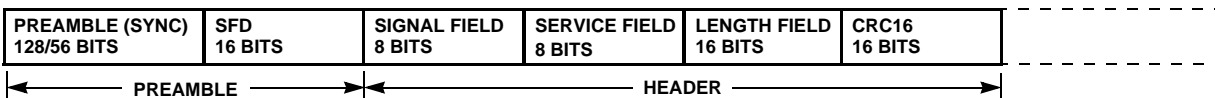

FIGURE 13. 802.11 PREAMBLE/HEADER

Scrambling is done by division with a prescribed polynomial as shown in Figure 14. A shift register holds the last quotient and the output is the exclusive or of the data and the sum of taps in the shift register. The transmit scrambler seed for the long preamble or for the short preamble can be set with CR48 or CR49.

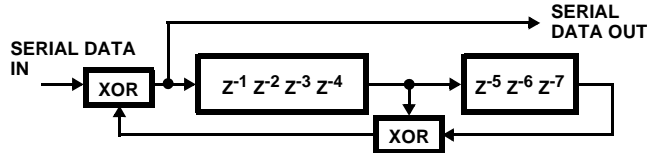

FIGURE 14. SCRAMBLING PROCESS

For the 1Mbps DBPSK data rates and for the header in all rates using the long preamble, the data coder implements the desired DBPSK coding by differential encoding the serial data from the scrambler and driving both the I and Q output channels together. For the 2Mbps DQPSK data rate and for the header in the short preamble mode, the data coder implements the desired coding as shown in the DQPSK Data Encoder table. This coding scheme results from differential coding of dibits (2 bits). Vector rotation is counterclockwise although bits 6 and 7 of configuration register CR1 can be used to reverse the rotation sense of the TX or RX signal if desired.

TABLE 16. DQPSK DATA ENCODER

PHASE SHIFT	DIBIT PATTERN (d0, d1) d0 IS FIRST IN TIME
0	00
+90	01
+180	11
-90	10

### Spread Spectrum Modulator Description

The modulator is designed to generate DBPSK, DQPSK, and CCK spread spectrum signals. The modulator is capable of automatically switching its rate where the preamble is DBPSK modulated, and the data and/or header are modulated differently. The modulator can support data rates of 1, 2, 5.5 and 11Mbps. The programming details to set up the modulator are given at the introductory paragraph of this section. The ISL3874 utilizes Quadrature (I/Q) modulation at baseband for all modulation modes.

In the 1Mbps DBPSK mode, the I and Q Channels are connected together and driven with the output of the scrambler and differential encoder. The I and Q Channels are then both multiplied with the 11-bit Barker word at the spread rate. The I and Q signals go to the Quadrature upconverter (HFA3724) to be modulated onto a carrier. Thus, the spreading and data modulation are BPSK modulated onto the carrier.

For the 2Mbps DQPSK mode, the serial data is formed into dibits or bit pairs in the differential encoder as detailed

above. One of the bits from the differential encoder goes to the I Channel and the other to the Q Channel. The I and Q Channels are then both multiplied with the 11-bit Barker word at the spread rate. This forms QPSK modulation at the symbol rate with BPSK modulation at the spread rate.

### Transmit Filter Description

To minimize the requirements on the analog transmit filtering, the transmit section shown in Figure 16 has an output digital filter. This filter is a Finite Impulse Response (FIR) style filter whose passband shape is set by tap coefficients. This filter shapes the spectrum to meet the radio spectral mask requirements while minimizing the peak to average amplitude on the output. To meet the particular spread spectrum processing gain regulatory requirements in Japan on channel 14, an extra FIR filter shape has been included that has a wider main lobe. This increases the 90% power bandwidth from about 11MHz to 14MHz. It has the unavoidable side effect of increasing the amplitude modulation, so the available transmit power is compromised by 2dB when using this filter (CR11, bit 5).

### CCK Modulation

For the CCK modes, the spreading code length is 8 complex chips and based on complementary codes. The chipping rate is 11Mchip/s. The following formula is used to derive the CCK code words that are used for spreading both 5.5 and 11Mbps:

$$c = \left\{ \begin{array}{l} e^{j(\varphi_1 + \varphi_2 + \varphi_3 + \varphi_4)}, e^{j(\varphi_1 + \varphi_3 + \varphi_4)}, e^{j(\varphi_1 + \varphi_2 + \varphi_4)}, \\ -e^{j(\varphi_1 + \varphi_4)}, e^{j(\varphi_1 + \varphi_2 + \varphi_3)}, e^{j(\varphi_1 + \varphi_3)}, -e^{j(\varphi_1 + \varphi_2)}, e^{j\varphi_1} \end{array} \right\}$$

(LSB to MSB), where  $c$  is the code word.

The terms:  $\varphi_1$ ,  $\varphi_2$ ,  $\varphi_3$ , and  $\varphi_4$  are defined below for 5.5Mbps and 11Mbps.

This formula creates 8 complex chips (LSB to MSB) that are transmitted LSB first. The coding is a form of the generalized Hadamard transform encoding where the phase  $\varphi_1$  is added to all code chips,  $\varphi_2$  is added to all odd code chips,  $\varphi_3$  is added to all odd pairs of code chips and  $\varphi_4$  is added to all odd quads of code chips.

The phase  $\varphi_1$  modifies the phase of all code chips of the sequence and is DQPSK encoded for 5.5 and 11Mbps. This will take the form of rotating the whole symbol by the appropriate amount relative to the phase of the preceding symbol. Note that the last chip of the symbol defined above is the chip that indicates the symbol's reference phase.

For the 5.5Mbps CCK mode, the output of the scrambler is partitioned into nibbles. The first two bits are encoded as differential symbol phase modulation in accordance with Table 17. All odd numbered symbols of the MPDU are given an extra 180 degree ( $\pi$ ) rotation in addition to the standard

DQPSK modulation as shown in the table. The symbols of the MPDU shall be numbered starting with "0" for the first symbol for the purposes of determining odd and even symbols. That is, the MPDU starts on an even numbered symbol. The last data dibits d2, and d3 CCK encode the basic symbol as specified in Table 18. This table is derived from the CCK formula above by setting  $\varphi_2 = (d_2 \cdot \pi) + \pi/2$ ,  $\varphi_3 = 0$ , and  $\varphi_4 = d_3 \cdot \pi$ . In the table d2 and d3 are in the order shown and the complex chips are shown LSB to MSB (left to right) with LSB transmitted first.

TABLE 17. DQPSK ENCODING TABLE

DIBIT PATTERN (d(0), d(1)) d(0) IS FIRST IN TIME	EVEN SYMBOLS PHASE CHANGE (+j $\omega$ )	ODD SYMBOLS PHASE CHANGE (+j $\omega$ )
00	0	$\pi$
01	$\pi/2$	$3\pi/2$ (- $\pi/2$ )
11	$\pi$	0
10	$3\pi/2$ (- $\pi/2$ )	$\pi/2$

TABLE 18. 5.5Mbps CCK ENCODING TABLE

d2, d3	CHIPS							
00	1j	1	1j	-1	1j	1	-1j	1
01	-1j	-1	-1j	1	1j	1	-1j	1
10	-1j	1	-1j	-1	-1j	1	1j	1
11	1j	-1	1j	1	-1j	1	1j	1

At 11Mbps, 8 bits (d0 to d7; d0 first in time) are transmitted per symbol.

The first dibit (d0, d1) encodes the phase  $\varphi_1$  based on DQPSK. The DQPSK encoder is specified in Table 17. The phase change for  $\varphi_1$  is relative to the phase  $\varphi_1$  of the preceding symbol. In the case of rate change, the phase change for  $\varphi_1$  is relative to the phase  $\varphi_1$  of the preceding CCK symbol. All odd numbered symbols of the MPDU are given an extra 180 degree ( $\pi$ ) rotation in accordance with the DQPSK modulation as shown in Table 17. Symbol numbering starts with "0" for the first symbol of the MPDU.

The data dibits: (d2, d3), (d4, d5), (d6, d7) encode  $\varphi_2$ ,  $\varphi_3$ , and  $\varphi_4$  respectively based on QPSK as specified in Table 19. Note that this table is binary, not Grey, coded.

TABLE 19. QPSK ENCODING TABLE

DIBIT PATTERN (d(i), d(i+1)) d(i) IS FIRST IN TIME	PHASE
00	0
01	$\pi/2$
10	$\pi$
11	$3\pi/2$ (- $\pi/2$ )

## TX Power Control

The transmitter power can be controlled via two registers. The first register, CR58, contains the digitized results of

power measurements by the ISL3874. By comparing this measurement to what is needed for transmit power, The MAC determines whether to raise or lower the transmit power. It does this by writing the power level desired to register CR31.

## Clear Channel Assessment (CCA) and Energy Detect (ED) Description

The Clear Channel Assessment (CCA) circuit implements the carrier sense portion of a Carrier Sense Multiple Access (CSMA) networking scheme. The Clear Channel Assessment (CCA) monitors the environment to determine when it is clear to transmit. The CCA circuit in the ISL3874 can be programmed to be a function of RSSI (energy detected on the channel), CS1, SQ1, or various combinations. The CCA is used by the Media Access Controller (MAC) in the ISL3874. The MAC decides on transmission based on traffic to send and the CCA indication. The CCA indication can be ignored, allowing transmissions independent of any channel conditions. The CCA in combination with the visibility of the various internal parameters (i.e., Energy Detection measurement results), can assist the MAC in executing algorithms that can adapt to the environment. These algorithms can increase network throughput by minimizing collisions and reducing transmissions liable to errors.

There are three measures that can be used in the CCA assessment. The receive signal strength indication (RSSI) which indicates the energy at the antenna, CS1 and carrier sense (SQ1). CS1 becomes active anytime the AGC portion of the circuit becomes unlocked, which is likely at the onset of a signal that is strong enough to support 11Mbps, but may not occur with the onset of a signal that is only strong enough to support 1 or 2Mbps. CS1 stays active until the AGC locks and a SQ1 assessment is done, if SQ1 is false, then CS1 is cleared, which deasserts CCA. If SQ1 is true, then tracking is begun, and CCA continues to show the channel busy. CS1 may occur at any time during acquisition as the AGC state machine runs asynchronously with respect to slot times.

SQ1 becomes active only when a spread signal with the proper PN code has been detected, and the peak correlation amplitude to sidelobe ratio exceeds a set threshold, so it may not be adequate in itself.

A SQ1 evaluation occurs whenever the AGC has remained locked for the entire data ingest period. When this happens, SQ1 is updated between 8 $\mu$ s and 9 $\mu$ s into the 10 $\mu$ s dwell. If CS1 is not active, two consecutive SQ1s are required to advance the part to tracking.

The state of CCA is not guaranteed from the time RX\_PE goes high until the first CCA assessment is made. At the end of a packet, after RXPE has been deasserted, the state of CCA is also not guaranteed.

The Receive Signal Strength Indication (RSSI) measurement is derived from the state of the AGC circuit. ED is the comparison



result of RSSI against a threshold. The threshold may be set to an absolute power value, or it may be set to be N dB above the measured noise floor. See CR35. The ISL3874 measures and stores the RSSI level when it detects no presence of BPSK or QPSK signals. The average value of a 256 value buffer is taken to be the noise floor. Thus, the value of the noise floor will adapt to the environment. A separate noise floor value is maintained for each antenna. An initial value of the noise floor is established within 50µs of the chip being active and is refined as time goes on. Deasserting RX\_PE does not corrupt the learned values. If the absolute power metric is chosen, this threshold is normally set to between -70dBm and -80dBm.

If desired, ED may be used in the acquisition process as well as CCA. ED may be used to mask (squell) weak signals and prevent radio reception of signals too weak to support the high data rates, signals from adjacent cells, networks, or buildings.

The Configuration registers effecting the CCA algorithm operation are summarized below (more programming details on these registers can be found under the Control Registers section of this document).

CR9(6:5) allow CCA to be programmed to be a function of ED only, the logical operation of (CS1 OR SQ1), the logical function of (ED AND (CS1 OR SQ1)), or (ED OR (CS1 OR SQ1)).

CR9(7) lets the user select from sampled CCA mode, which means CCA will not glitch, is updated once per symbol and is valid for reading at 15.8µs or 18.7µs. In non-sampled mode, CCA may change at any time, potentially several times per slot, as ED and CS1 operate asynchronously to slot times.

In a typical system CCA will be monitored to determine when the channel is clear. Once the channel is detected busy, CCA should be checked periodically to determine if the channel becomes clear. Once MD\_RDY goes active, CCA should be ignored for the remainder of the message. Failure to monitor CCA until MD\_RDY goes active (or use of a time-out circuit) could result in a stalled system as it is possible for the channel to be busy and then become clear without an MD\_RDY occurring.

## AGC Description

The AGC system consists of the 3 chips handling the receive signal, the RF to IF downconverter HFA3683, the IF to baseband converter HFA3783, and the baseband processor (BBP) section of the ISL3874. The AGC loop (Figure 11) is digitally controlled by the BBP. Basically it operates as follows:

Initially, the receiver is set for high gain. The percent of time that the A/D converters in the baseband processor are saturated is monitored along with signal amplitude and the gain is adjusted down until the amplitude is what will optimize the demodulator's performance. If the amount of saturation is great, the initial gain adjust steps are large. If the signal overload is small, they are less. When the gain is about right and the A/Ds' outputs are within the lock window

(CR19), the BBP declares AGC lock and stops adjusting for the duration of the packet. If the signal level then varies more than a preset amount (CR20, CR29), the AGC is declared unlocked and the gain again allowed to readjust.

The BBP looks for the locked state following an unlocked state (CS1) as one indication that a received signal is on the antenna. This starts the receive process of looking for PN correlation (SQ1). Once PN correlation and AGC lock are found, the processor begins acquisition.

For large signals, the power level in the RF stage output is also monitored and if it is large, the LNA stage gain is dropped. This removes 30dB of gain from the receive chain which is compensated for by replacing 30dB of gain in the IF AGC stage. There is some hysteresis in this operation and once the AGC locks, it is locked as well. This improves the receiver dynamic range.

## RX\_RF\_AGC Pad Operation

### 30dB Pad Engaging (RF Chip Low Gain)

If the AGC is not locked onto a packet, a '1' on the *ifCompDet* (see notes below) state will engage in the 30dB attenuation pad. This causes the AGC to go out of lock and also forces the attenuation accumulator to be set to the programmed value of CR27. The AGC then attempts to lock on the signal.

If the AGC is locked on a packet, *ifCompDet* is ignored.

### 30dB Pad Releasing (RF Chip High Gain)

If the AGC is not locked onto a packet and the attenuation accumulator sum falls below the programmable threshold (CR27), the pad will release. This is for the case where a noise spike kicked in the 30dB pad and the pad should release when the noise spike ends. Since the noise floor is different for different environments, it is possible that in many cases CR27's programmed value will be below the noise floor and the pad will not be removed except by RXPE going low. There is a recommended value to program CR27 (24dB), but that depends on what environment the radio is in.

During a packet (after AGC lock), the 30dB pad is held constant and the CR27 threshold is ignored.

RXPE low forces the pad to release whether in the middle of a packet or not. At the end of a packet, RXPE always goes low, forcing the pad to release.

The following notes apply:

- The attenuation accumulator is basically about equal to the current RSSI value.
- The accumulator output, after going through the interpolator lookup table, feeds the AGC D/A.
- The pad value is programmable (CR17), but is recommended to be set to 30dB.

**ifCompDet** is a signal generated in the ISL3874 from the HFA3783 chip. A '1' indicates its inputs are near saturation and it needs the RF chip to switch from high gain to low gain.

**RX\_IF\_Det** is the input to the ISL3874 chip from the HFA3783 which is transferred to **ifCompDet** on the HFA3874.

**RX\_RF\_AGC** is the output of the ISL3874 chip and '1' is high gain, '0' is low gain.

## Demodulator Description

The receiver portion of the baseband processor, performs A/D conversion and demodulation of the spread spectrum signal. It correlates the PN spread symbols, then demodulates the DBPSK, DQPSK, or CCK symbols. The demodulator includes a frequency tracking loop that tracks and removes the carrier frequency offset. In addition, it tracks the symbol timing, and differentially decodes and descrambles the data. The data is output through the RX Port to the external processor.

The PRISM baseband processor in the ISL3874 uses differentially coherent demodulation. The ISL3874 is designed to achieve rapid settling of the carrier tracking loop during acquisition. Rapid phase fluctuations are handled with a relatively wide loop bandwidth which is then stepped down as the packet progresses. Coherent processing improves the BER performance margin as opposed to differentially coherent processing for the CCK data rates.

The baseband processor uses time invariant correlation to strip the Barker code spreading and phase processing to demodulate the resulting signals in the header and DBPSK/DQPSK demodulation modes. These operations are illustrated in Figure 18 which is an overall block diagram of the receiver processor.

In processing the DBPSK header, input samples from the I and Q A/D converters are correlated to remove the spreading sequence. The peak position of the correlation pulse is used to determine the symbol timing. The sample stream is decimated to the symbol rate and corrected for frequency offset prior to PSK demodulation. Phase errors from the demodulator are fed to the NCO through a lead/lag filter to maintain phase lock. The carrier is de-rotated by the carrier tracking loop. The

demodulated data is differentially decoded and descrambled before being sent to the header detection section.

In the 1Mbps DBPSK mode, data demodulation is performed the same as in header processing. In the 2Mbps DQPSK mode, the demodulator demodulates two bits per symbol and differentially decodes these bit pairs. The bits are then serialized and descrambled prior to being sent to the output.

In the CCK modes, the receiver removes carrier frequency offsets and uses a bank of correlators to detect the modulation. A biggest picker finds the largest correlation in the I and Q Channels and determines the sign of those correlations. For this to happen, the demodulator must know the starting phase which is determined by referencing the data to the last bit of the header. Each symbol demodulated determines 1 or 2 nibbles of data. This is then serialized and descrambled before being passed to the output.

Carrier tracking is via a lead/lag filter using a digital Costas phase detector. Chip tracking in the CCK modes is chip decision directed or slaved to the carrier tracking depending on whether or not the locked oscillator design is utilized in the radio.

## Acquisition Description

A projected worst case time line for the acquisition of a signal with a short preamble and header is shown. The synchronization part of the preamble is 56 symbols long followed by a 16-bit SFD. The receiver must monitor the antenna to determine if a signal is present. The timeline is broken into 10 $\mu$ s blocks (dwells) for the scanning process. This length of time is necessary to allow enough integration of the signal to make a good acquisition decision. This worst case time line example assumes that the signal arrives part way into the first dwell such as to just barely catch detection. The signal and the scanning process are asynchronous and the signal could start anywhere. In this timeline, it is assumed that the signal is present in the first 10 $\mu$ s dwell, but was missed due to power amplifier ramp up.

Meanwhile signal quality and signal frequency measurements are made simultaneous with symbol timing measurements. A CS1 followed by SQ1 active, or two

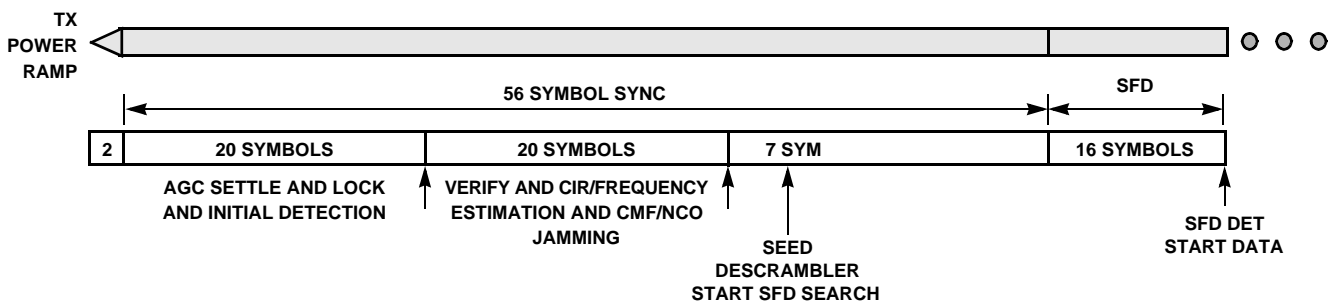

FIGURE 15. ACQUISITION TIMELINE, NON DIVERSITY

consecutive SQ1s will cause the part to finish the acquisition phase and enter the tracking phase.

Prior to initial acquisition the NCO is inactive (0Hz) and carrier phase measurement are done on a symbol by symbol basis. After acquisition, coherent DPSK demodulation is in effect. After a brief setup time as illustrated on the timeline, the signal begins to emerge from the demodulator.

It takes 7 more symbols to seed the descrambler before valid data is available. This occurs in time for the SFD to be received. At this time the demodulator is tracking and in the coherent PSK demodulation mode so it will no longer acquire new signals. If a much larger signal overrides the signal being demodulated (a collision), the demodulator will abort the tracking process and attempt to acquire the new signal. Failure to find an SFD within the SFD timeout interval will result in a receiver reset and return to acquisition mode.

### Channel Matched Filter (CMF) Description

The receive section shown in Figure 18 operates on the RAKE receiver principle which maximizes the SNR of the signal by combining the energy of multipath signal components. The RAKE receiver is implemented with a Channel Matched Filter (CMF) using a FIR filter structure with 16 taps. The CMF is programmed by calculating the Channel Impulse Response (CIR) of the channel and mathematically manipulating that to form the tap coefficients of the CMF. Thus, the CMF is set to compensate the channel characteristics that distort the signal. Since the calculation of the CIR is inaccurate at low SNR or in the presence of strong CW interference, the chip has thresholds (CR36 to CR39) that are set to substitute a default CMF shape under those conditions. This default CMF shape is designed to compensate only the known transmit and receive non linearity.

### PN Correlators Description

There are two types of correlators in the ISL3874 baseband processor. The first is a parallel matched filter correlator that correlates for the Barker sequence used in preamble, header, and PSK data modes. This Barker code correlator is designed to handle BPSK spreading with carrier offsets up to  $\pm 50$ ppm and 11 chips per symbol. Since the spreading is BPSK, the correlator is implemented with two real correlators, one for the I and one for the Q Channel. The same Barker sequence is always used for both I and Q correlators.

These correlators are time invariant matched filters otherwise known as parallel correlators. They use one sample per chip for correlation although two samples per chip are processed. The correlator despreads the samples from the chip rate back to the original symbol rate giving 10.4dB processing gain for 11 chips per symbol. While despreads the desired signal, the correlator spreads the energy of any non correlating interfering signal.

The second form of correlator is the parallel correlator bank used for detection of the CCK modulation. For the CCK modes, the 64 wide bank of parallel correlators is implemented with a Fast Walsh Transform to correlate the 4 or 64 code possibilities. This greatly simplifies the circuitry of the correlation function. It is followed by a biggest picker which finds the biggest of 4 or 64 correlator outputs depending on the rate. This is translated into 2 or 6 data bits. The detected output is then processed through the differential phase decoder to demodulate the last two bits of the symbol.

### Data Demodulation and Tracking Description (DBPSK and DQPSK Modes)

The signal is demodulated from the correlation peaks tracked by the symbol timing loop (bit sync) as shown in Figure 18. The frequency and phase of the signal is corrected using the NCO that is driven by the phase locked loop. Averaging the phase errors over 10 symbols gives the necessary frequency information for seeding the NCO operation.

### Data Decoder and Descrambler Description

The data decoder that implements the desired DQPSK coding/decoding as shown in Table 20. The data is formed into pairs of bits called dibits. The left bit of the pair is the first in time. This coding scheme results from differential coding of the dibits. Vector rotation is counterclockwise for a positive phase shift, but can be reversed with bit 7 or 6 of CR1.

For DBPSK, the decoding is simple differential decoding.

TABLE 20. DQPSK DATA DECODER

PHASE SHIFT	DIBIT PATTERN (D0, D1) D0 IS FIRST IN TIME
0	00
+90	01
+180	11
-90	10

The data scrambler and de-scrambler are self synchronizing circuits. They consist of a 7-bit shift register with feedback of some of the taps of the register. The scrambler is designed to ensure smearing of the discrete spectrum lines produced by the PN code.

One thing to keep in mind is that both the differential decoding and the descrambling cause error extension or burst errors. This is due to two properties of the processing. First, the differential decoding process causes errors to occur on pairs of symbols. When a symbol's phase is in error, the next symbol will also be decoded wrong since the data is encoded in the change in phase from one symbol to the next. Thus, two errors are made on two successive symbols. Therefore up to 4 bits may be wrong although on the average only 2 are. In QPSK mode, these may occur next to one another or separated by up

to 2 bits. In the CCK mode, when a symbol decision error is made, up to 6 bits may be in error although on average only 3 bits will be in error. Secondly, when the bits are processed by the descrambler, these errors are further extended. The descrambler is a 7-bit shift register with two taps exclusive or'ed with the bit stream. Thus, each error is extended by a factor of three. Multiple errors can be spaced the same as the tap spacing, so they can be canceled in the descrambler. In this case, two wrongs do make a right. Given all that, if a single

error is made the whole packet is discarded anyway, so the error extension property has no effect on the packet error rate. It should be taken into account if a forward error correction scheme is contemplated.

Descrambling is self synchronizing and is done by a polynomial division using a prescribed polynomial. A shift register holds the last quotient and the output is the exclusive-or of the data and the sum of taps in the shift register.

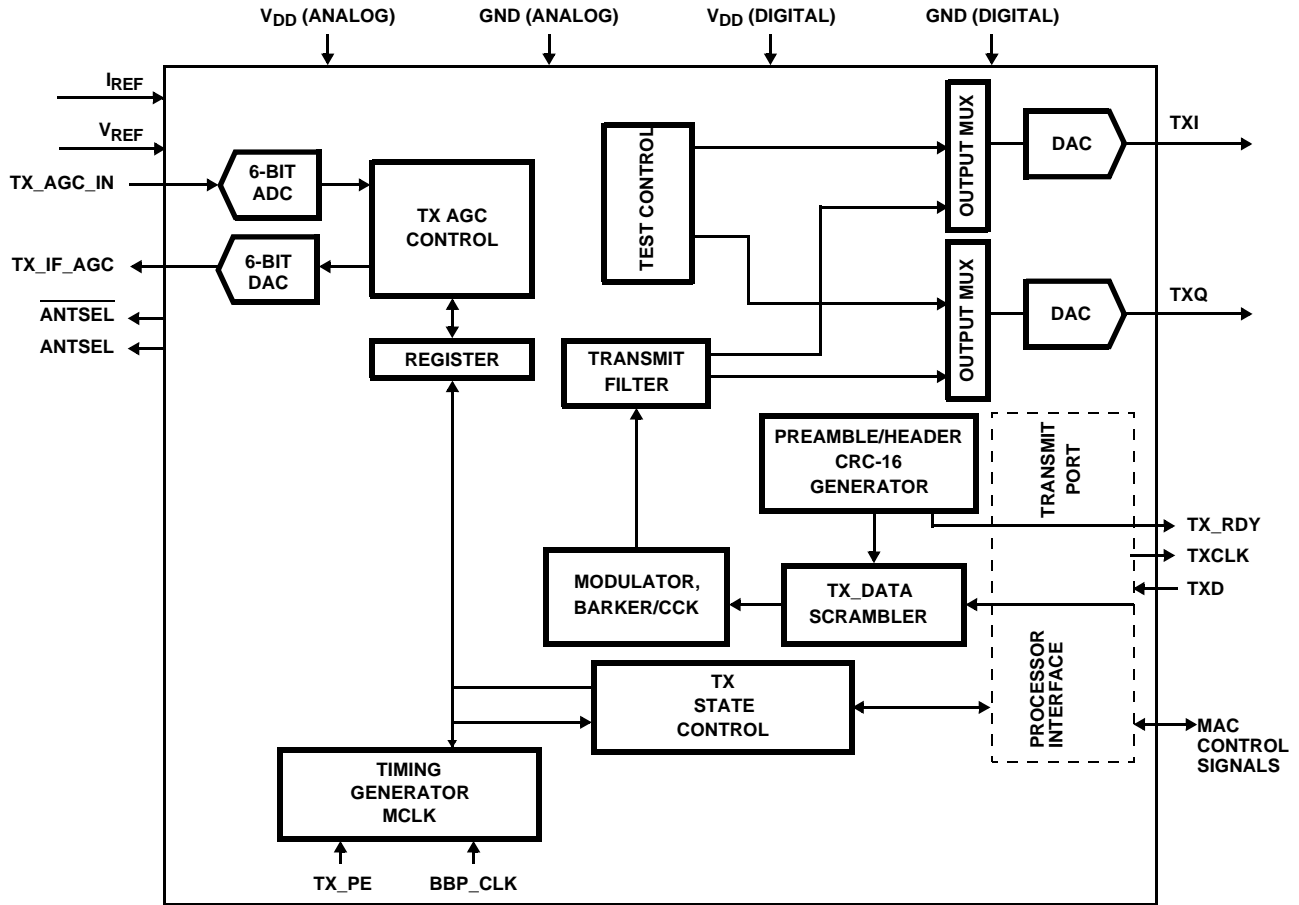

FIGURE 16. DSSS BASEBAND PROCESSOR, TRANSMIT SECTION

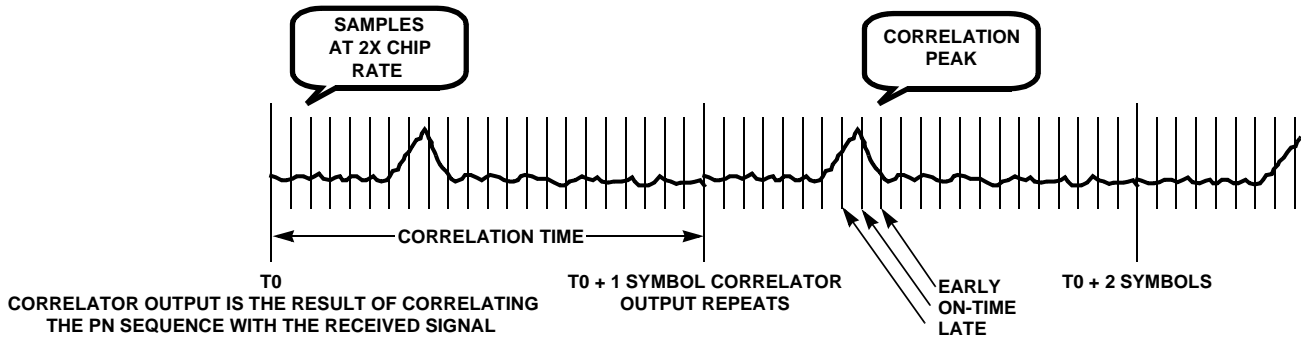

FIGURE 17. CORRELATION PROCESS

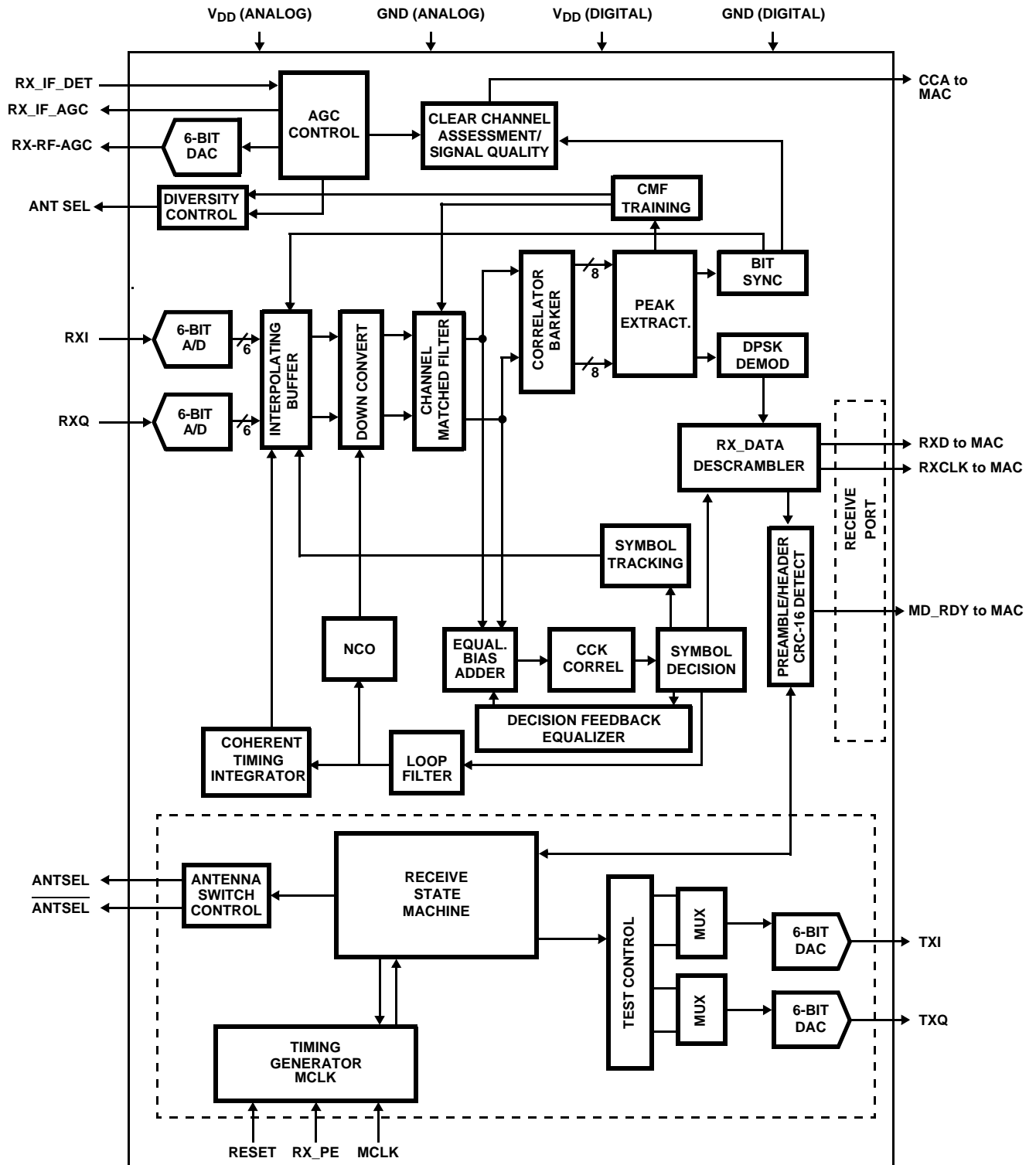

FIGURE 18. DSSS BASEBAND PROCESSOR, RECEIVE SECTION



## Data Demodulation in the CCK Modes

In this mode, the demodulator uses Complementary Code Keying (CCK) modulation for the two highest data rates. It is slaved to the low rate processor which it depends on for acquisition of initial timing and phase tracking information. The low rate section acquires the signal, locks up symbol and carrier tracking loops, and determines the data rate to be used for the data.

The demodulator for the CCK modes takes over when the preamble and header have been acquired and processed. On the last bit of the header, the phase of the signal is captured and used as a phase reference for the high rate differential demodulator.

The signal from the A/D converters is carrier frequency and phase corrected by a DESPIN stage. This removes the frequency offset and aligns the I and Q Channels properly for the correlators. The sample rate is decimated to 11MSPS for the correlators after the DESPIN since the data is now synchronous in time.

The demodulator knows the symbol timing, so the correlation is batch processed over each symbol. The correlation outputs from the correlator are compared to each other in a biggest picker and the chosen one determines 6 bits of the symbol. The QPSK phase of the chosen one determines two more bits for a total of 8 bits per symbol. Six bits come from which of the 64 correlators had the largest output and the last two are determined from the QPSK differential demod of that output. In the 5.5Mbps mode, only 4 of the correlator outputs are monitored. This demodulates 2 bits for which of 4 correlators had the largest output and 2 more for the QPSK demodulation of that output for a total of 4 bits per symbol.

## Equalizer Description

The ISL3874 employs a Decision Feedback Equalizer (DFE) to improve performance in the presence of significant multipath distortion. The DFE combats Inter Chip Interference (ICI) and Inter Symbol Interference (ISI). The equalizer is trained on the sample data collected during the first part of the acquisition after the AGC has settled and the antenna selected. The same data is used for CMF calculations and equalizer training. Once the equalizer has been set up, it is used to process the incoming symbols in a decision feedback manner. After the Fast Walsh transform is performed, the detected symbols are corrected for ICI before the bigger picker where the symbol decision process is performed. Once a symbol has been demodulated, the calculated residual energy from that symbol is subtracted from the incoming data for the next symbol. That corrects for the ISI component. The DFE is not adapted during the packet as the channel impulse response is not expected to vary significantly during that brief time. Register CR10 bits 4 and 5 can disable these equalizers separately.

## Tracking

Carrier tracking is performed on the de-rotated signal samples from the complex multiplier in a four phase Costas loop. This forms the error term that is integrated in the lead/lag filter for the NCO, closing the loop. Tracking is only measured when there is a chip transition. Note that this tracking is dependent on a positive SNR in the chip rate bandwidth.

The symbol clock is tracked by a sample interpolator that can adjust the sample timing forwards and backwards by 72 increments of 1/8th chip. This approach means that the ISL3874 can only track an offset in timing for a finite interval before the limits of the interpolator are reached. Thus, continuous demodulation is not possible.

## Locked Oscillator Tracking

Symbol tracking can be slaved to the carrier offset tracking for improved performance as long as at both the transmitting and the receiving radios, the bit clocks and carrier frequency clocks are locked to common crystal oscillators. A bit carried in the SERVICE field (bit 2) indicates whether or not the transmitter has locked clocks. When the same bit is set at the receiver (CR6, bit 2), the receiver knows it can track the bit clock by counting down the carrier tracking offset. This is much more accurate than tracking the bit clock directly. CR33, bit 6 can enable or disable this capability.

## Demodulator Performance

This section indicates the typical performance measures for a radio design. The performance data below should be used as a guide. In general, the actual performance depends on the application, interference environment, RF/IF implementation and radio component selection.

## Overall Eb/N0 Versus BER Performance

The PRISM chip set has been designed to be robust and energy efficient in packet mode communications. The demodulator uses coherent processing for data demodulation. Figures 19 and 20 show the performance of the baseband processor when used in conjunction with the HFA3783 IF and the PRISM recommended IF filters. Off the shelf test equipment are used for the RF processing. The curves should be used as a guide to assess performance in a complete implementation.

Factors for carrier phase noise, multipath, and other degradations will need to be considered on an implementation by implementation basis in order to predict the overall performance of each individual system.

Figure 19 shows the curves for theoretical DBPSK/DQPSK demodulation with coherent demodulation and descrambling as well as the PRISM performance measured for DBPSK and DQPSK. The theoretical performance for DBPSK and DQPSK are the same as shown on the diagram. Figure 20 shows the theoretical and actual

performance of the CCK modes. The losses in both figures include RF and IF radio losses; they do not reflect the ISL3874 losses alone. The ISL3874 baseband processing losses from theoretical are, by themselves, a small percentage of the overall loss.

The PRISM demodulator performs with an implementation loss of less than 4dB from theoretical in a AWGN environment with low phase noise local oscillators. For the 1 and 2Mbps modes, the observed errors occurred in groups of 4 and 6 errors. This is because of the error extension properties of differential decoding and descrambling. For the 5.5Mbps and 11Mbps modes, the errors occur in symbols of 4 or 8 bits each and are further extended by the descrambling. Therefore the error patterns are less well defined.

### Clock Offset Tracking Performance

The PRISM baseband processor is designed to accept data clock offsets of up to  $\pm 25$ ppm for each end of the link (TX and RX). This effects both the acquisition and the tracking performance of the demodulator. The budget for clock offset error is 0.75dB at  $\pm 50$ ppm. No appreciable degradation was seen for operation in AWGN at  $\pm 50$ ppm. Symbol tracking is accomplished by one of two methods. If both ends of the link employ locked oscillators for their bit timing and carrier frequency generation, symbol tracking is done by dividing down the carrier frequency offset. If either one of the ends of the link do not have locked oscillators, then symbol tracking is done by a conventional early-late chip tracking method.

### Carrier Offset Frequency Performance

The correlators used for acquisition for all modes and for demodulation in the 1 and 2Mbps modes are time invariant matched filter correlators otherwise known as parallel correlators. They use two samples per chip and are tapped at every other shift register stage. Their performance with carrier frequency offsets is determined by the phase roll rate due to the offset. For an offset of +50ppm (combined for both TX and RX) will cause the carrier to phase roll 22.5 degrees over the length of the correlator. This causes a loss of 0.22dB in correlation magnitude which translates directly to  $E_b/N_0$  performance loss. In the PRISM chip design, the carrier phase locked loop is inactive during acquisition. During tracking, the carrier tracking loop corrects for offset, so that no degradation is noted. In the presence of high multipath and high SNR, however, some degradation is expected.

### RSSI Performance

The RSSI value is reported on CR62 in hex and is linear with signal level in dB. Figure 21 shows the RSSI curve measured on a whole evaluation radio. This takes into account the full gain adjust range of all radio parts. To get signal level in dBm on a radio, simply subtract 100 from the RSSI value in decimal.

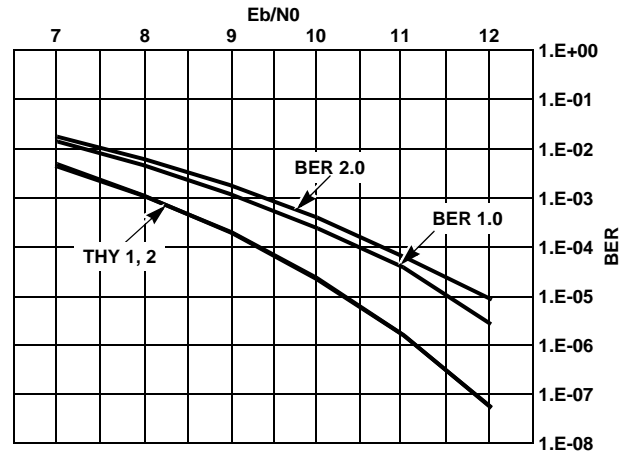

FIGURE 19. BER vs  $E_b/N_0$  PERFORMANCE FOR PSK MODES

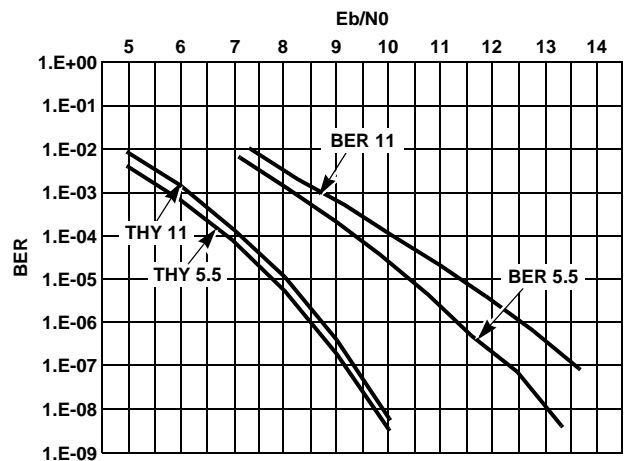

FIGURE 20. BER vs  $E_b/N_0$  PERFORMANCE FOR CCK MODES

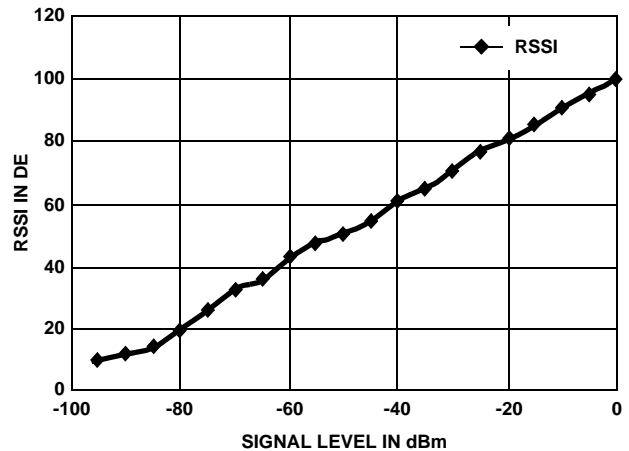

FIGURE 21. RSSI vs SIGNAL LEVEL

## Signal Quality Estimate

A signal quality measure is available on CR51 for use by the MAC. This measure is the SNR in the carrier tracking loop and can be used to determine when the demodulator is working near to the noise floor and likely to make errors. Figure 22 shows the performance of the SQ measure versus signal to noise level.

## ED Threshold

The performance of the ED threshold is shown in Figure 23. Setting this threshold will effect CCA only. Using ED as part of the CCA measure will allow deferral to large signals even if they are not correlated to the desired spread signals.

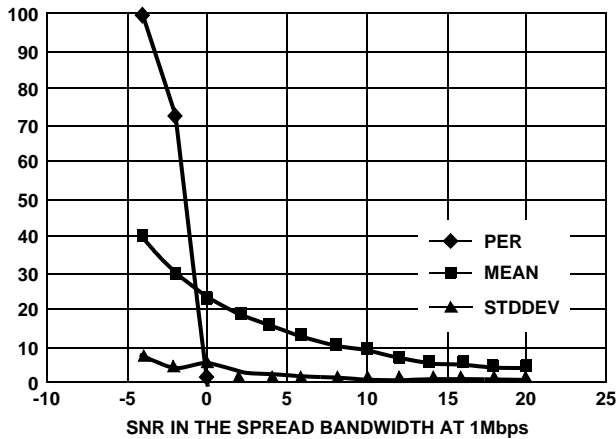

FIGURE 22. SIGNAL QUALITY MEASURE AND PER vs SNR

ED can be read from CR61 bit 4. Using ED and RSSI can assist the MAC in determining the presence of non-correlating signals such as frequency hoppers or microwave ovens. For example, the MAC can elect to try to transmit

over microwave oven interference but not count the results in rate shifting algorithms.

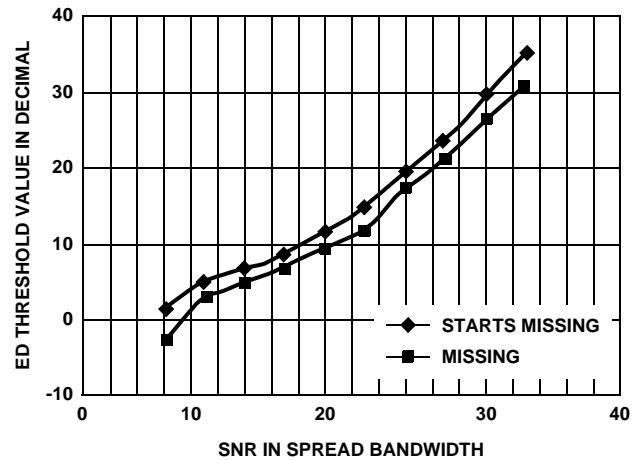

FIGURE 23. ED THRESHOLD vs SNR IN dB AT 1Mbps

## A Default Register Configuration

The registers in the ISL3874 are addressed with 7-bit numbers where the lower 1 bit of an 8-bit hexadecimal address is left as unused. This results in the addresses being in increments of 2. The data is transmitted as either DBPSK, DQPSK, or CCK depending on the configuration chosen. It is recommended that you start with the simplest configuration (DBPSK) for initial test and verification of the device and/or the radio design. The user can later modify the CR contents to reflect the system and the required performance of each specific application. The Firmware sets the registers in accordance with a \*.pda file. Be sure to consult the latest "pda" file for the device which is maintained on the Intersil WEB site.



**Plastic Ball Grid Array Packages (BGA)**

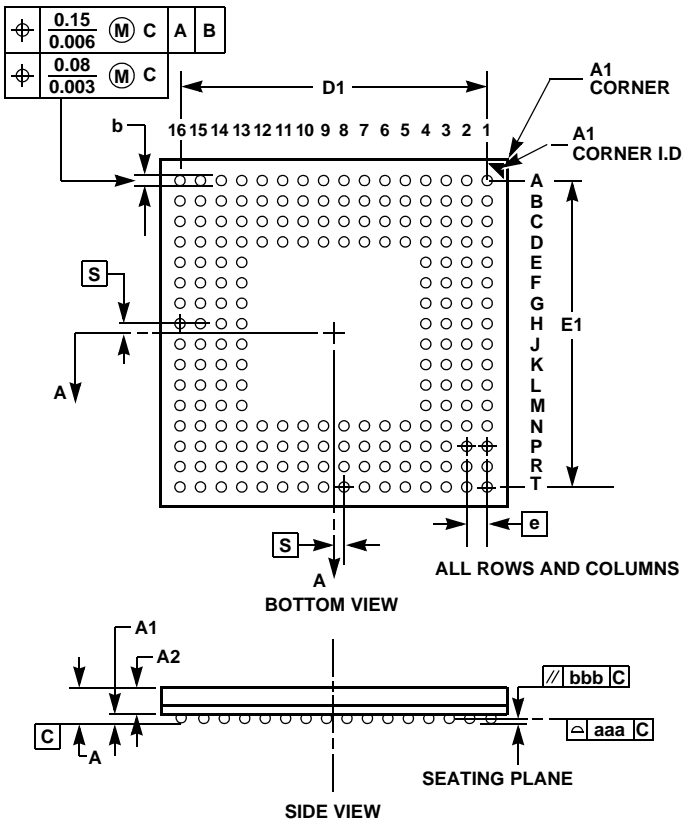
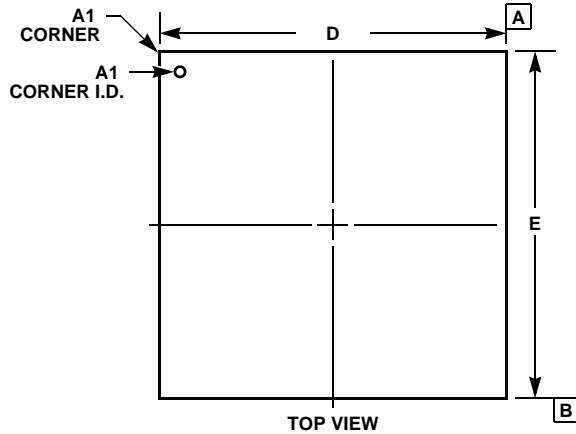

**V192.14x14**  
**192 BALL PLASTIC BALL GRID ARRAY PACKAGE**

SYMBOL	INCHES		MILLIMETERS		NOTES
	MIN	MAX	MIN	MAX	
A	-	0.059	-	1.40	-
A1	0.012	0.016	0.31	0.41	-
A2	0.033	0.039	0.83	0.99	-
b	0.016	0.020	0.41	0.51	7
D/E	0.547	0.555	13.90	14.10	-
D1/E1	0.468	0.476	11.90	12.10	-
N	192		192		-
e	0.032 BSC		0.80 BSC		-
MD/ME	16 x 16		16 x 16		3
bbb	0.004		0.10		-
aaa	0.005		0.12		-

Rev. 1 1/01

**NOTES:**

1. Controlling dimension: MILLIMETER. Converted inch dimensions are not necessarily exact.
2. Dimensioning and tolerancing conform to ASME Y14.5M-1994.
3. "MD" and "ME" are the maximum ball matrix size for the "D" and "E" dimensions, respectively.
4. "N" is the maximum number of balls for the specific array size.
5. Primary datum C and seating plane are defined by the spherical crowns of the contact balls.
6. Dimension "A" includes standoff height "A1", package body thickness and lid or cap height "A2".
7. Dimension "b" is measured at the maximum ball diameter, parallel to the primary datum C.
8. Pin "A1" is marked on the top and bottom sides adjacent to A1.
9. "S" is measured with respect to datum's A and B and defines the position of the solder balls nearest to package centerlines. When there is an even number of balls in the outer row the value is "S" = e/2.

All Intersil products are manufactured, assembled and tested utilizing ISO9000 quality systems.

Intersil Corporation's quality certifications can be viewed at website [www.intersil.com/design/quality](http://www.intersil.com/design/quality)

*Intersil products are sold by description only. Intersil Corporation reserves the right to make changes in circuit design and/or specifications at any time without notice. Accordingly, the reader is cautioned to verify that data sheets are current before placing orders. Information furnished by Intersil is believed to be accurate and reliable. However, no responsibility is assumed by Intersil or its subsidiaries for its use; nor for any infringements of patents or other rights of third parties which may result from its use. No license is granted by implication or otherwise under any patent or patent rights of Intersil or its subsidiaries.*

For information regarding Intersil Corporation and its products, see web site [www.intersil.com](http://www.intersil.com)

**Sales Office Headquarters**

**NORTH AMERICA**  
 Intersil Corporation  
 2401 Palm Bay Rd., Mail Stop 53-204  
 Palm Bay, FL 32905  
 TEL: (321) 724-7000  
 FAX: (321) 724-7240

**EUROPE**  
 Intersil SA  
 Mercure Center  
 100, Rue de la Fusee  
 1130 Brussels, Belgium  
 TEL: (32) 2.724.2111  
 FAX: (32) 2.724.22.05

**ASIA**  
 Intersil Ltd.  
 8F-2, 96, Sec. 1, Chien-kuo North,  
 Taipei, Taiwan 104  
 Republic of China  
 TEL: 886-2-2515-8508  
 FAX: 886-2-2515-8369