

DATA SHEET

For a complete data sheet, please also download:

- The IC04 LOCMOS HE4000B Logic Family Specifications HEF, HEC
- The IC04 LOCMOS HE4000B Logic Package Outlines/Information HEF, HEC

HEF4086B

gates

4-wide 2-input AND-OR-invert gate

Product specification
File under Integrated Circuits, IC04

January 1995

4-wide 2-input AND-OR-invert gate

HEF4086B
gates

DESCRIPTION

The HEF4086B is a 4-wide 2-input AND-OR-invert (AOI) gate with two additional inputs (I_8 or \bar{I}_9) which can be used as either expander or inhibit inputs by connecting them to any standard LOCMOS output. A HIGH on I_8 or a LOW on \bar{I}_9 forces the output (O) LOW independent of the other eight inputs (I_0 to I_7). The output (O) is fully buffered for highest noise immunity and pattern insensitivity of output impedance.

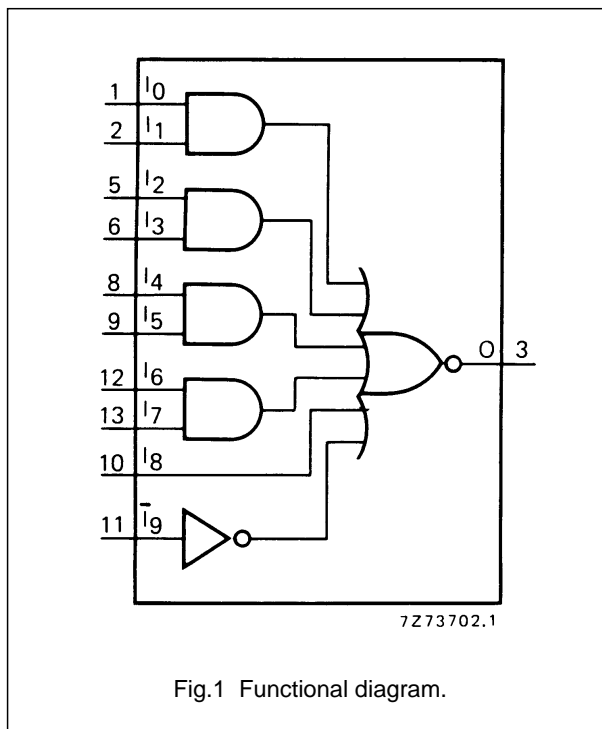

Fig.1 Functional diagram.

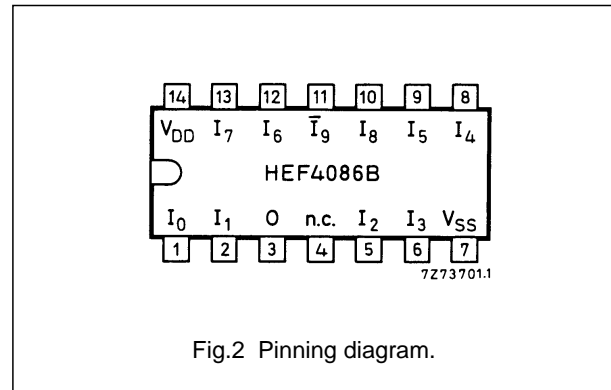

Fig.2 Pinning diagram.

HEF4086BP(N): 14-lead DIL; plastic
(SOT27-1)

HEF4086BD(F): 14-lead DIL; ceramic (cerdip)
(SOT73)

HEF4086BT(D): 14-lead SO; plastic
(SOT108-1)

(): Package Designator North America

PINNING

I_0 to I_8 gate inputs
 \bar{I}_9 gate input (active LOW)
O output (active LOW)

FAMILY DATA, I_{DD} LIMITS category GATES

See Family Specifications

4-wide 2-input AND-OR-invert gate

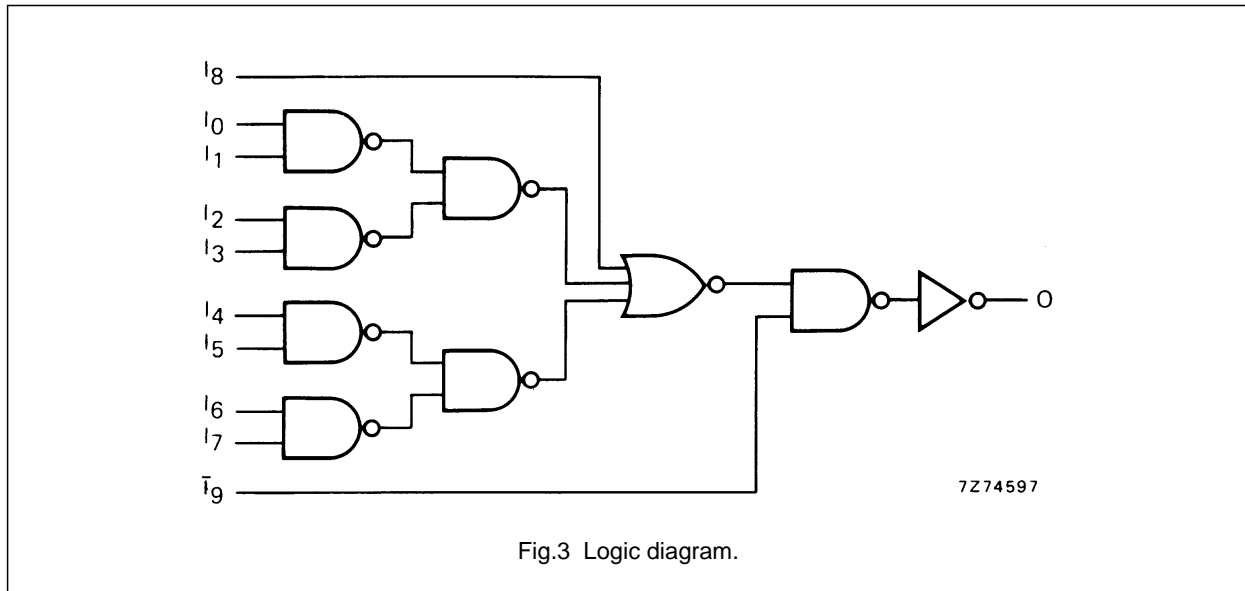
HEF4086B
gates

LOGIC EQUATION

$$O = \overline{I_0 \cdot I_1 + I_2 \cdot I_3 + I_4 \cdot I_5 + I_6 \cdot I_7 + I_8 + I_9}$$

4-wide 2-input AND-OR-invert gate

HEF4086B
gates**AC CHARACTERISTICS** $V_{SS} = 0\text{ V}$; $T_{amb} = 25\text{ °C}$; $C_L = 50\text{ pF}$; input transition times $\leq 20\text{ ns}$

	V_{DD} V	SYMBOL	TYP.	MAX.		TYPICAL EXTRAPOLATION FORMULA						
Propagation delays	5	t_{PHL}	90	180	ns	63 ns + (0,55 ns/pF) C_L						
							HIGH to LOW	10	30	65	ns	19 ns + (0,23 ns/pF) C_L
	5	t_{PLH}	80	155	ns	53 ns + (0,55 ns/pF) C_L						
							LOW to HIGH	10	30	60	ns	19 ns + (0,23 ns/pF) C_L
	5	t_{PHL}	70	140	ns	43 ns + (0,55 ns/pF) C_L						
							HIGH to LOW	10	25	55	ns	14 ns + (0,23 ns/pF) C_L
	5	t_{PLH}	55	115	ns	28 ns + (0,55 ns/pF) C_L						
							LOW to HIGH	10	20	40	ns	9 ns + (0,23 ns/pF) C_L
5	t_{PHL}	55	105	ns	28 ns + (0,55 ns/pF) C_L							
						HIGH to LOW	10	20	45	ns	9 ns + (0,23 ns/pF) C_L	
												15
5	t_{PLH}	45	90	ns	18 ns + (0,55 ns/pF) C_L							
						LOW to HIGH	10	15	35	ns	4 ns + (0,23 ns/pF) C_L	
												15
5	t_{THL}	60	120	ns	10 ns + (1,0 ns/pF) C_L							
						Output transition times HIGH to LOW	10	30	60	ns	9 ns + (0,42 ns/pF) C_L	
												15
5	t_{TLH}	60	120	ns	10 ns + (1,0 ns/pF) C_L							
						LOW to HIGH	10	30	60	ns	9 ns + (0,42 ns/pF) C_L	
												15

	V_{DD} V	TYPICAL FORMULA FOR P (μW)	
Dynamic power dissipation per package (P)	5	$525 f_i + \sum (f_o C_L) \times V_{DD}^2$	where f_i = input freq. (MHz) f_o = output freq. (MHz) C_L = load capacitance (pF) $\sum (f_o C_L)$ = sum of outputs V_{DD} = supply voltage (V)
	10	$2600 f_i + \sum (f_o C_L) \times V_{DD}^2$	
	15	$7300 f_i + \sum (f_o C_L) \times V_{DD}^2$	

4-wide 2-input AND-OR-invert gate

HEF4086B
gates

APPLICATION INFORMATION

Figure 4 shows two HEF4086B ICs connected to obtain an 8-wide 2-input AOI function. The output (O_A) of the first IC is fed directly into the \bar{I}_{9B} gate input of the second IC. Similarly, any NAND gate output can be fed directly into the \bar{I}_9 gate input to obtain a 5-wide AOI function. In addition, any AND gate output can be fed directly into the I_8 gate input with the same result.

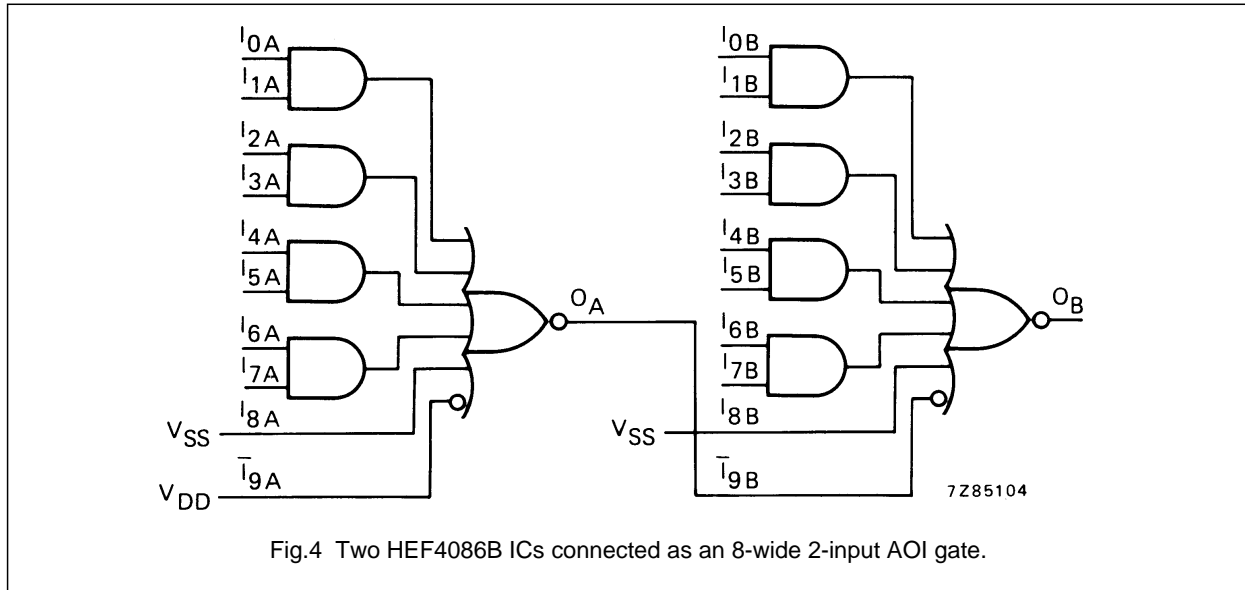

Logic equation for Fig.4:

$$O_B = \overline{I_{0A} \cdot I_{1A} + I_{2A} \cdot I_{3A} + I_{4A} \cdot I_{5A} + I_{6A} \cdot I_{7A}} + I_{0B} \cdot I_{1B} + I_{2B} \cdot I_{3B} + I_{4B} \cdot I_{5B} + I_{6B} \cdot I_{7B}$$