



CYPRESS



CY7C138AV/144AV/006AV
CY7C139AV/145AV/016AV
CY7C007AV/017AV

3.3V 4K/8K/16K/32K x 8/9
Dual-Port Static RAM

Features

- True Dual-Ported memory cells which allow simultaneous access of the same memory location
- 4K/8K/16K/32K x 8 organizations (CY7C0138AV/144AV/006AV/007AV)
- 4K/8K/16K/32K x 9 organizations (CY7C0139AV/145AV/016AV/017AV)
- 0.35-micron CMOS for optimum speed/power
- High-speed access: 20/25 ns
- Low operating power
 - Active: $I_{CC} = 115 \text{ mA}$ (typical)
 - Standby: $I_{SB3} = 10 \mu\text{A}$ (typical)
- Fully asynchronous operation
- Automatic power-down
- Expandable data bus to 16/18 bits or more using Master/Slave chip select when using more than one device
- On-chip arbitration logic
- Semaphores included to permit software handshaking between ports
- $\overline{\text{INT}}$ flag for port-to-port communication
- Pin select for Master or Slave
- Commercial and Industrial Temperature Ranges
- Available in 68-pin PLCC (all) and 64-pin TQFP (7C006AV & 7C144AV)
- Pb-Free packages available

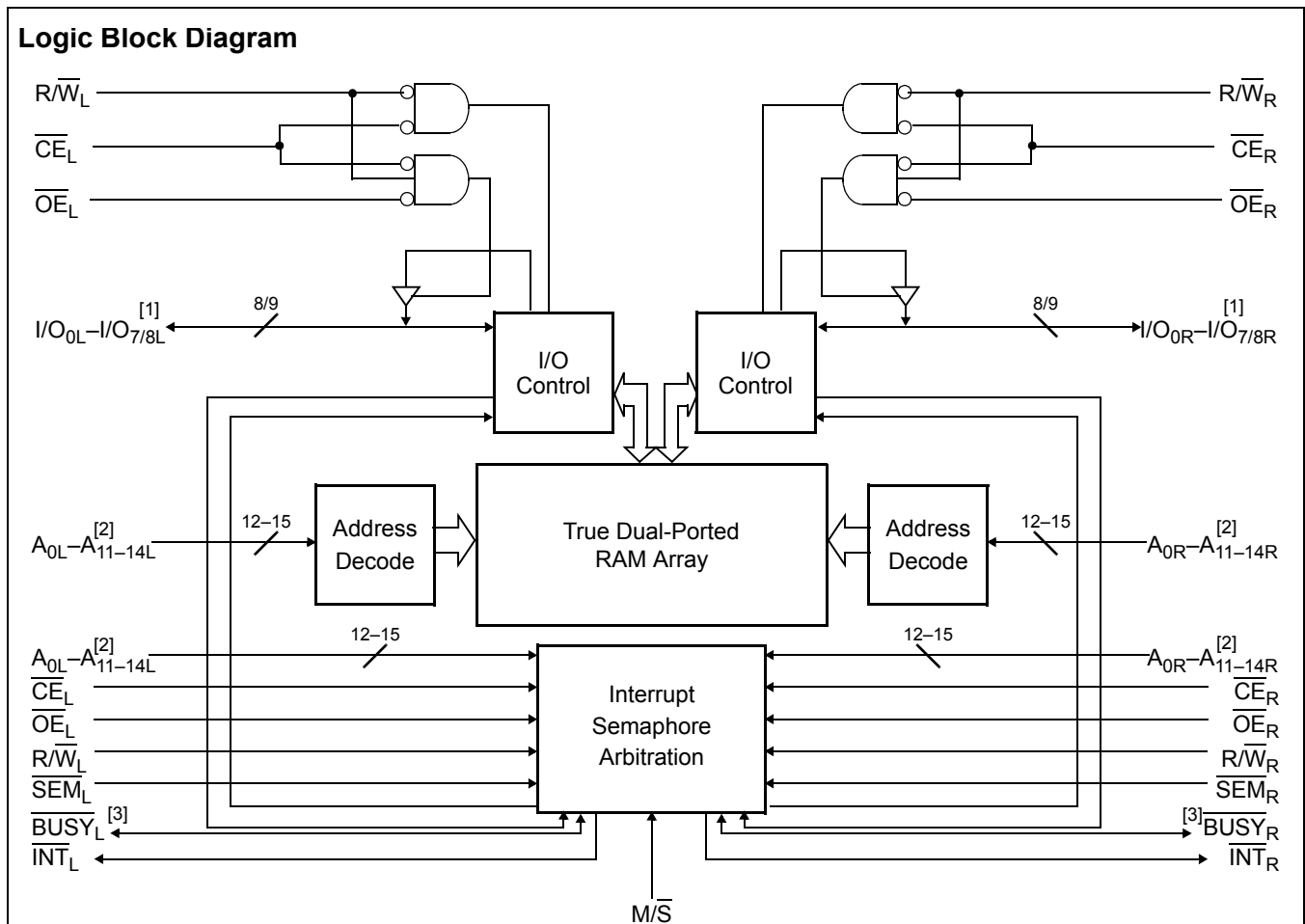

For the most recent information, visit the Cypress web site at www.cypress.com

Notes:

1. $I/O_0-I/O_7$ for x8 devices; $I/O_0-I/O_8$ for x9 devices.
2. A_0-A_{11} for 4K devices; A_0-A_{12} for 8K devices; A_0-A_{13} for 16K devices; A_0-A_{14} for 32K devices;
3. BUSY is an output in master mode and an input in slave mode.

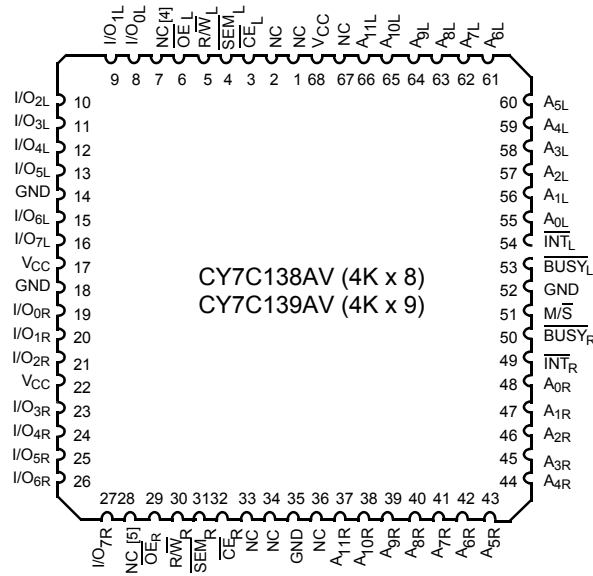
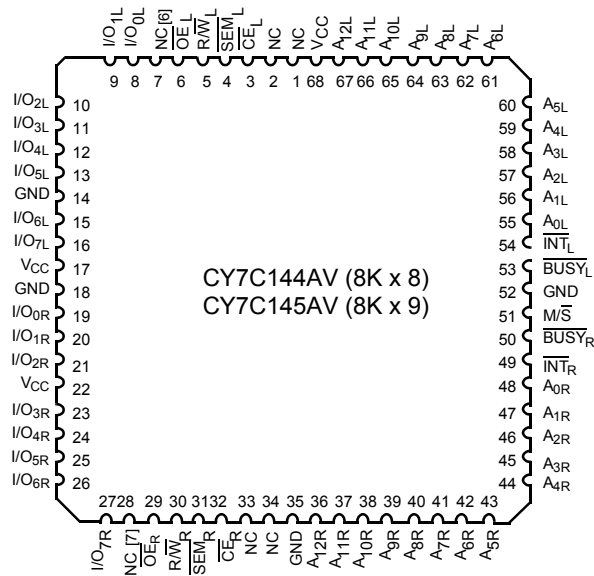
Pin Configurations
**68-Pin PLCC
 Top View**

**68-Pin PLCC
 Top View**

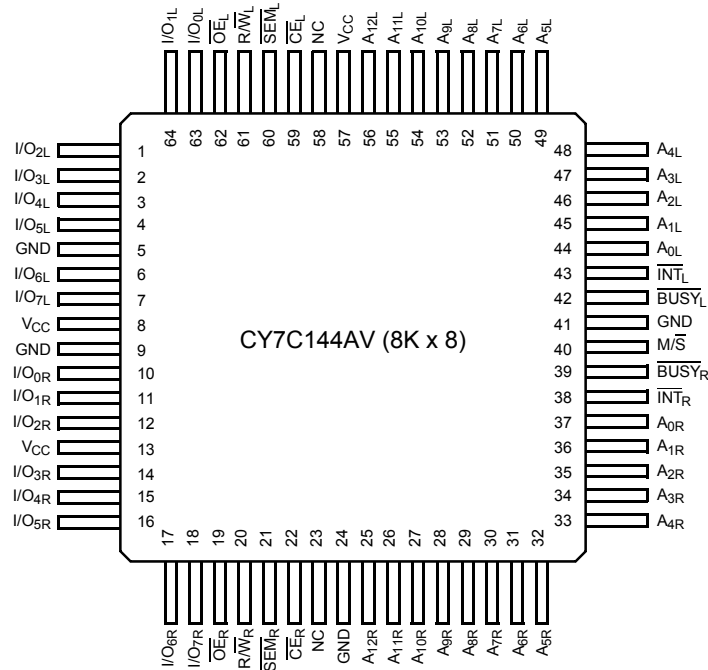
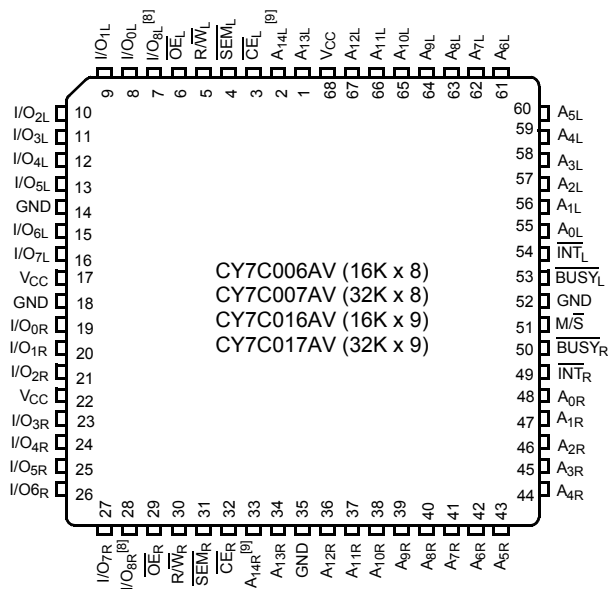
Notes:

4. I/O_{8L} on the CY7C139AV.
5. I/O_{8R} on the CY7C139AV.
6. I/O_{8L} on the CY7C145AV.
7. I/O_{8R} on the CY7C145AV.

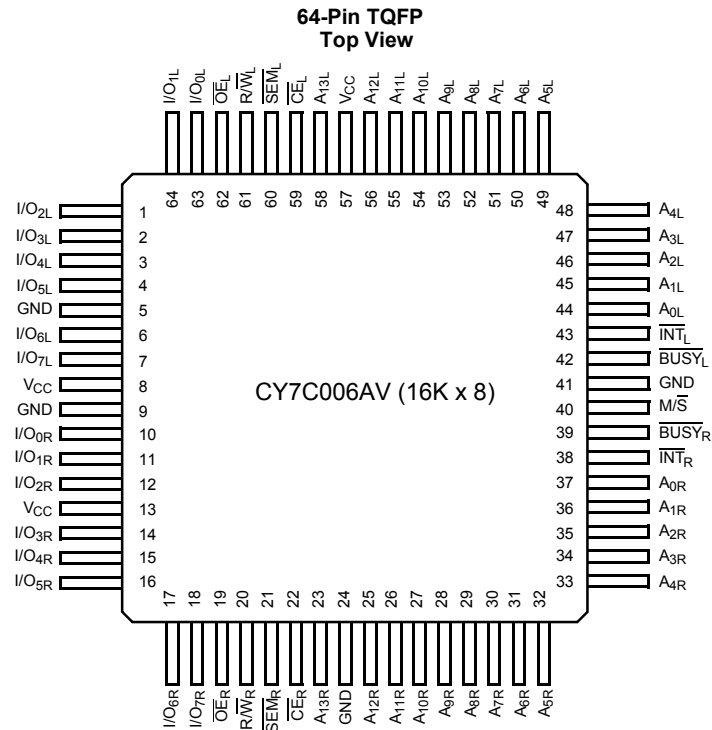
Pin Configurations (continued)
**64-Pin TQFP
Top View**

**68-Pin PLCC
Top View**

Notes:

8. I/O for CY7C016AV and CY7C017AV only. NC for other parts.
9. Address line for CY7C007AV and CY7C017AV only. NC for other parts.

Pin Configurations (continued)

Selection Guide

	CY7C138AV/144AV/006AV CY7C139AV/145AV/016AV CY7C007AV/017AV -20	CY7C138AV/144AV/006AV CY7C139AV/145AV/016AV CY7C007AV/017AV -25
Maximum Access Time (ns)	20	25
Typical Operating Current (mA)	120	115
Typical Standby Current for I_{SB1} (mA) (Both Ports TTL level)	35	30
Typical Standby Current for I_{SB3} (μ A) (Both Ports CMOS level)	10 μ A	10 μ A

Pin Definitions

Left Port	Right Port	Description
\overline{CE}_L	\overline{CE}_R	Chip Enable
R/\overline{W}_L	R/\overline{W}_R	Read/Write Enable
\overline{OE}_L	\overline{OE}_R	Output Enable
$A_{0L}-A_{14L}$	$A_{0R}-A_{14R}$	Address (A_0-A_{11} for 4K devices; A_0-A_{12} for 8K devices; A_0-A_{13} for 16K devices; A_0-A_{14} for 32K)
$I/O_{0L}-I/O_{8L}$	$I/O_{0R}-I/O_{8R}$	Data Bus Input/Output ($I/O_0-I/O_7$ for x8 devices and $I/O_0-I/O_8$ for x9)
\overline{SEM}_L	\overline{SEM}_R	Semaphore Enable
\overline{INT}_L	\overline{INT}_R	Interrupt Flag
\overline{BUSY}_L	\overline{BUSY}_R	Busy Flag
M/S		Master or Slave Select
V_{CC}		Power
GND		Ground
NC		No Connect

Architecture

The CY7C138AV/144AV/006AV/007AV and CY7C139AV/145AV/016AV/017AV consist of an array of 4K, 8K, 16K, and 32K words of 8 and 9 bits each of dual-port RAM cells, I/O and address lines, and control signals (CE, OE, R/W). These control pins permit independent access for reads or writes to any location in memory. To handle simultaneous writes/reads to the same location, a BUSY pin is provided on each port. Two interrupt (INT) pins can be utilized for port-to-port communication. Two semaphore (SEM) control pins are used for allocating shared resources. With the M/S pin, the device can function as a master (BUSY pins are outputs) or as a slave (BUSY pins are inputs). The device also has an automatic power-down feature controlled by \overline{CE} . Each port is provided with its own output enable control (OE), which allows data to be read from the device.

Functional Description

The CY7C138AV/144AV/006AV/007AV and CY7C139AV/145AV/016AV/017AV are low-power CMOS 4K, 8K, 16K, and 32K x8/9 dual-port static RAMs. Various arbitration schemes are included on the devices to handle situations when multiple processors access the same piece of data. Two ports are provided, permitting independent, asynchronous access for reads and writes to any location in memory. The devices can be utilized as standalone 8/9-bit dual-port static RAMs or multiple devices can be combined in order to function as a 16/18-bit or wider master/slave dual-port static RAM. An M/S pin is provided for implementing 16/18-bit or wider memory applications without the need for separate master and slave devices or additional discrete logic. Application areas include interprocessor/multiprocessor designs, communications status buffering, and dual-port video/graphics memory.

Each port has independent control pins: Chip Enable (\overline{CE}), Read or Write Enable (R/W), and Output Enable (\overline{OE}). Two flags are provided on each port (BUSY and INT). BUSY signals that the port is trying to access the same location currently being accessed by the other port. The Interrupt flag (INT) permits communication between ports or systems by means of a mail box. The semaphores are used to pass a flag,

or token, from one port to the other to indicate that a shared resource is in use. The semaphore logic is comprised of eight shared latches. Only one side can control the latch (semaphore) at any time. Control of a semaphore indicates that a shared resource is in use. An automatic power-down feature is controlled independently on each port by a Chip Select (CE) pin.

Read and Write Operations

When writing data must be set up for a duration of t_{SD} before the rising edge of R/W in order to guarantee a valid write. A write operation is controlled by either the R/W pin (see Write Cycle No. 1 waveform) or the CE pin (see Write Cycle No. 2 waveform). Required inputs for non-contention operations are summarized in Table 1.

If a location is being written to by one port and the opposite port attempts to read that location, a port-to-port flowthrough delay must occur before the data is read on the output; otherwise the data read is not deterministic. Data will be valid on the port t_{DD} after the data is presented on the other port.

When reading the device, the user must assert both the \overline{OE} and \overline{CE} pins. Data will be available t_{ACE} after \overline{CE} or t_{DOE} after \overline{OE} is asserted. If the user wishes to access a semaphore flag, then the SEM pin must be asserted instead of the CE pin and \overline{OE} must also be asserted.

Interrupts

The upper two memory locations may be used for message passing. The highest memory location (FFF for the CY7C138AV/9AV, 1FFF for the CY7C144AV/5AV, 3FFF for the CY7C006AV/16AV, 7FFF for the CY7C007AV/17AV) is the mailbox for the right port and the second-highest memory location (FFE for the CY7C138AV/9AV, 1FFE for the CY7C144AV/5AV, 3FFE for the CY7C006AV/16AV, 7FFE for the CY7C007AV/17AV) is the mailbox for the left port. When one port writes to the other port's mailbox, an interrupt is generated to the owner. The interrupt is reset when the owner reads the contents of the mailbox. The message is user defined.

Each port can read the other port's mailbox without resetting the interrupt. The active state of the busy signal (to a port)

prevents the port from setting the interrupt to the winning port. Also, an active busy to a port prevents that port from reading its own mailbox and, thus, resetting the interrupt to it. If an application does not require message passing, do not connect the interrupt pin to the processor's interrupt request input pin. The operation of the interrupts and their interaction with Busy are summarized in *Table 2*.

Busy

The CY7C138AV/144AV/006AV/007AV and CY7C139AV/145AV/016AV/017AV provide on-chip arbitration to resolve simultaneous memory location access (contention). If both ports' CEs are asserted and an address match occurs within t_{PS} of each other, the busy logic will determine which port has access. If t_{PS} is violated, one port will definitely gain permission to the location, but it is not predictable which port will get that permission. \overline{BUSY} will be asserted t_{BLA} after an address match or t_{BLC} after CE is taken LOW.

Master/Slave

An $\overline{M/S}$ pin is provided in order to expand the word width by configuring the device as either a master or a slave. The \overline{BUSY} output of the master is connected to the \overline{BUSY} input of the slave. This will allow the device to interface to a master device with no external components. Writing to slave devices must be delayed until after the \overline{BUSY} input has settled (t_{BLC} or t_{BLA}), otherwise, the slave chip may begin a write cycle during a contention situation. When tied HIGH, the $\overline{M/S}$ pin allows the device to be used as a master and, therefore, the \overline{BUSY} line is an output. \overline{BUSY} can then be used to send the arbitration outcome to a slave.

Semaphore Operation

The CY7C138AV/144AV/006AV/007AV and CY7C139AV/145AV/016AV/017AV provide eight semaphore latches, which are separate from the dual-port memory locations. Semaphores are used to reserve resources that are shared between the two ports. The state of the semaphore indicates that a resource is in use. For example, if the left port wants to

request a given resource, it sets a latch by writing a zero to a semaphore location. The left port then verifies its success in setting the latch by reading it. After writing to the semaphore, SEM or OE must be deasserted for t_{SOP} before attempting to read the semaphore. The semaphore value will be available $t_{SWRD} + t_{DOE}$ after the rising edge of the semaphore write. If the left port was successful (reads a zero), it assumes control of the shared resource, otherwise (reads a one) it assumes the right port has control and continues to poll the semaphore. When the right side has relinquished control of the semaphore (by writing a one), the left side will succeed in gaining control of the semaphore. If the left side no longer requires the semaphore, a one is written to cancel its request.

Semaphores are accessed by asserting \overline{SEM} LOW. The SEM pin functions as a chip select for the semaphore latches (CE must remain HIGH during SEM LOW). A_{0-2} represents the semaphore address. OE and R/W are used in the same manner as a normal memory access. When writing or reading a semaphore, the other address pins have no effect.

When writing to the semaphore, only I/O₀ is used. If a zero is written to the left port of an available semaphore, a one will appear at the same semaphore address on the right port. That semaphore can now only be modified by the side showing zero (the left port in this case). If the left port now relinquishes control by writing a one to the semaphore, the semaphore will be set to one for both sides. However, if the right port had requested the semaphore (written a zero) while the left port had control, the right port would immediately own the semaphore as soon as the left port released it. *Table 3* shows sample semaphore operations.

When reading a semaphore, all data lines output the semaphore value. The read value is latched in an output register to prevent the semaphore from changing state during a write from the other port. If both ports attempt to access the semaphore within t_{SPS} of each other, the semaphore will definitely be obtained by one side or the other, but there is no guarantee which side will control the semaphore.



Maximum Ratings^[10]

(Above which the useful life may be impaired. For user guidelines, not tested.)

Storage Temperature-65°C to +150°C
 Ambient Temperature with
 Power Applied.....-55°C to +125°C
 Supply Voltage to Ground Potential -0.5V to +4.6V
 DC Voltage Applied to
 Outputs in High Z State.....-0.5V to $V_{CC}+0.5V$
 DC Input Voltage^[11]-0.5V to $V_{CC}+0.5V$

Output Current into Outputs (LOW)..... 20 mA
 Static Discharge Voltage..... >2001V
 Latch-Up Current..... >200 mA

Operating Range

Range	Ambient Temperature	V _{CC}
Commercial	0°C to +70°C	3.3V ± 300 mV
Industrial ^[12]	-40°C to +85°C	3.3V ± 300 mV

Electrical Characteristics Over the Operating Range

Parameter	Description	CY7C138AV/144AV/006AV CY7C139AV/145AV/016AV CY7C007AV/017AV						
		-20			-25			Unit
		Min.	Typ.	Max.	Min.	Typ.	Max.	
V _{OH}	Output HIGH Voltage (V _{CC} = 3.3V)	2.4			2.4			V
V _{OL}	Output LOW Voltage			0.4			0.4	V
V _{IH}	Input HIGH Voltage	2.0			2.0			V
V _{IL}	Input LOW Voltage			0.8			0.8	V
I _{OZ}	Output Leakage Current	-10		10	-10		10	µA
I _{CC}	Operating Current (V _{CC} = Max., I _{OUT} = 0 mA) Outputs Disabled	Com'1.	120	175		115	165	mA
		Ind. ^[12]	140	195				mA
I _{SB1}	Standby Current (Both Ports TTL Level) CE _L & CE _R ≥ V _{IH} , f = f _{MAX} ^[13]	Com'1.	35	45		30	40	mA
		Ind. ^[12]	45	55				mA
I _{SB2}	Standby Current (One Port TTL Level) CE _L CE _R ≥ V _{IH} , f = f _{MAX} ^[13]	Com'1.	75	110		65	95	mA
		Ind. ^[12]	85	130				mA
I _{SB3}	Standby Current (Both Ports CMOS Level) CE _L & CE _R ≥ V _{CC} - 0.2V, f = 0 ^[13]	Com'1.	10	500		10	500	µA
		Ind. ^[12]	10	500				µA
I _{SB4}	Standby Current (One Port CMOS Level) CE _L CE _R ≥ V _{IH} , f = f _{MAX} ^[13]	Com'1.	70	95		60	80	mA
		Ind. ^[12]	80	105				mA

Capacitance^[14]

Parameter	Description	Test Conditions	Max.	Unit
C _{IN}	Input Capacitance	T _A = 25°C, f = 1 MHz, V _{CC} = 3.3V	10	pF
C _{OUT}	Output Capacitance		10	pF

Notes:

- 10. The Voltage on any input or I/O pin can not exceed the power pin during power-up.
- 11. Pulse width < 20 ns.
- 12. Industrial parts are available in CY7C007AV and CY7C017AV only.
- 13. f_{MAX} = 1/t_{RC}. All inputs cycling at f = 1/t_{RC} (except output enable). f = 0 means no address or control lines change. This applies only to inputs at CMOS level standby I_{SB3}.
- 14. Tested initially and after any design or process changes that may affect these parameters.

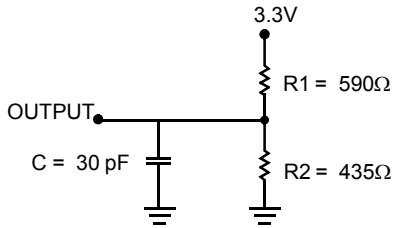
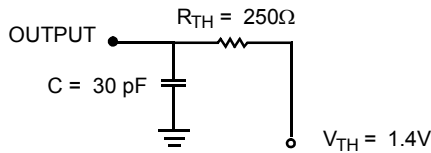
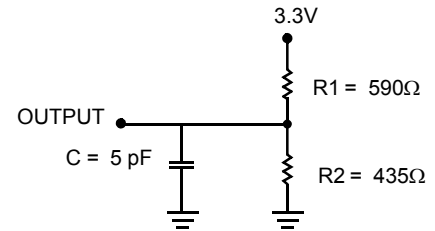
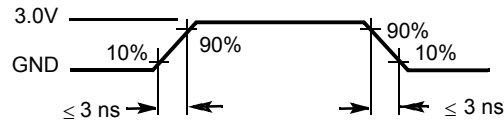
AC Test Loads and Waveforms

(a) Normal Load (Load 1)

**(b) Thévenin Equivalent (Load 1)
ALL INPUT PULSES**

**(c) Three-State Delay (Load 2)
(Used for t_{LZ} , t_{HZ} , t_{HZWE} & t_{LZWE} including scope and jig)**

Switching Characteristics Over the Operating Range^[15]

Parameter	Description	CY7C138AV/144AV/006AV CY7C139AV/145AV/016AV CY7C007AV/017AV				Unit
		-20		-25		
		Min.	Max.	Min.	Max.	
READ CYCLE						
t_{RC}	Read Cycle Time	20		25		ns
t_{AA}	Address to Data Valid		20		25	ns
t_{OHA}	Output Hold From Address Change	3		3		ns
$t_{ACE}^{[16]}$	\overline{CE} LOW to Data Valid		20		25	ns
t_{DOE}	\overline{OE} LOW to Data Valid		12		13	ns
$t_{LZOE}^{[17, 18, 19]}$	\overline{OE} Low to Low Z	3		3		ns
$t_{HZOE}^{[17, 18, 19]}$	\overline{OE} HIGH to High Z		12		15	ns
$t_{LZCE}^{[17, 18, 19]}$	\overline{CE} LOW to Low Z	3		3		ns
$t_{HZCE}^{[17, 18, 19]}$	\overline{CE} HIGH to High Z		12		15	ns
$t_{PU}^{[19]}$	\overline{CE} LOW to Power-Up	0		0		ns
$t_{PD}^{[19]}$	\overline{CE} HIGH to Power-Down		20		25	ns
WRITE CYCLE						
t_{WC}	Write Cycle Time	20		25		ns
$t_{SCE}^{[16]}$	\overline{CE} LOW to Write End	16		20		ns
t_{AW}	Address Valid to Write End	16		20		ns
t_{HA}	Address Hold From Write End	0		0		ns
$t_{SA}^{[16]}$	Address Set-Up to Write Start	0		0		ns
t_{PWE}	Write Pulse Width	16		20		ns
t_{SD}	Data Set-Up to Write End	12		15		ns

Notes:

15. Test conditions assume signal transition time of 3 ns or less, timing reference levels of 1.5V, input pulse levels of 0 to 3.0V, and output loading of the specified I_{O}/I_{OH} and 30-pF load capacitance.
16. To access RAM, $\overline{CE}=L$, $\overline{SEM}=H$. To access semaphore, $\overline{CE}=H$ and $\overline{SEM}=L$. Either condition must be valid for the entire t_{SCE} time.
17. At any given temperature and voltage condition for any given device, t_{HZCE} is less than t_{LZCE} and t_{HZOE} is less than t_{LZOE} .
18. Test conditions used are Load 3.
19. This parameter is guaranteed but not tested. For information on port-to-port delay through RAM cells from writing port to reading port, refer to Read Timing with Busy waveform.

Switching Characteristics Over the Operating Range^[15] (continued)

Parameter	Description	CY7C138AV/144AV/006AV CY7C139AV/145AV/016AV CY7C007AV/017AV				Unit
		-20		-25		
		Min.	Max.	Min.	Max.	
t_{HD}	Data Hold From Write End	0		0		ns
$t_{HZWE}^{[18, 19]}$	R/W LOW to High Z		12		15	ns
$t_{LZWE}^{[18, 19]}$	R/W HIGH to Low Z	3		3		ns
$t_{WDD}^{[20]}$	Write Pulse to Data Delay		40		50	ns
$t_{DDD}^{[20]}$	Write Data Valid to Read Data Valid		30		35	ns
BUSY TIMING^[21]						
t_{BLA}	BUSY LOW from Address Match		20		20	ns
t_{BHA}	BUSY HIGH from Address Mismatch		20		20	ns
t_{BLC}	BUSY LOW from \overline{CE} LOW		20		20	ns
t_{BHC}	BUSY HIGH from \overline{CE} HIGH		16		17	ns
t_{PS}	Port Set-Up for Priority	5		5		ns
t_{WB}	R/W HIGH after BUSY (Slave)	0		0		ns
t_{WH}	R/W HIGH after BUSY HIGH (Slave)	15		17		ns
$t_{BDD}^{[22]}$	BUSY HIGH to Data Valid		20		25	ns
INTERRUPT TIMING^[21]						
t_{INS}	\overline{INT} Set Time		20		20	ns
t_{INR}	\overline{INT} Reset Time		20		20	ns
SEMAPHORE TIMING						
t_{SOP}	SEM Flag Update Pulse (\overline{OE} or \overline{SEM})	10		12		ns
t_{SWRD}	SEM Flag Write to Read Time	5		5		ns
t_{SPS}	SEM Flag Contention Window	5		5		ns
t_{SAA}	SEM Address Access Time		20		25	ns

Data Retention Mode

The CY7C0138AV/144AV/006AV/007AV and CY7C139AV/145AV/016AV/017AV are designed with battery backup in mind. Data retention voltage and supply current are guaranteed over temperature. The following rules ensure data retention:

1. Chip enable (\overline{CE}) must be held HIGH during data retention, within V_{CC} to $V_{CC} - 0.2V$.
2. \overline{CE} must be kept between $V_{CC} - 0.2V$ and 70% of V_{CC} during the power-up and power-down transitions.
3. The RAM can begin operation $>t_{RC}$ after V_{CC} reaches the minimum operating voltage (3.0 volts).

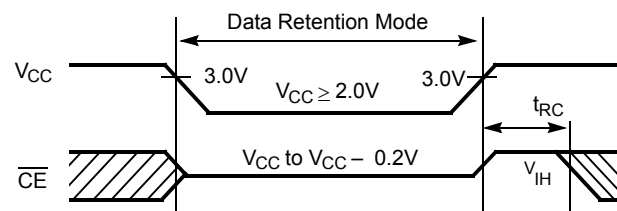
Timing

Parameter	Test Conditions ^[23]	Max.	Unit
I_{CCDR1}	@ $V_{CCDR} = 2V$	50	μA

Notes:

20. For information on port-to-port delay through RAM cells from writing port to reading port, refer to Read Timing with Busy waveform.
21. Test conditions used are Load 2.
22. t_{BDD} is a calculated parameter and is the greater of $t_{WDD} - t_{PWE}$ (actual) or $t_{DDD} - t_{SD}$ (actual).
23. $CE = V_{CC}$, $V_{in} = GND$ to V_{CC} , $T_A = 25^\circ C$. This parameter is guaranteed but not tested.

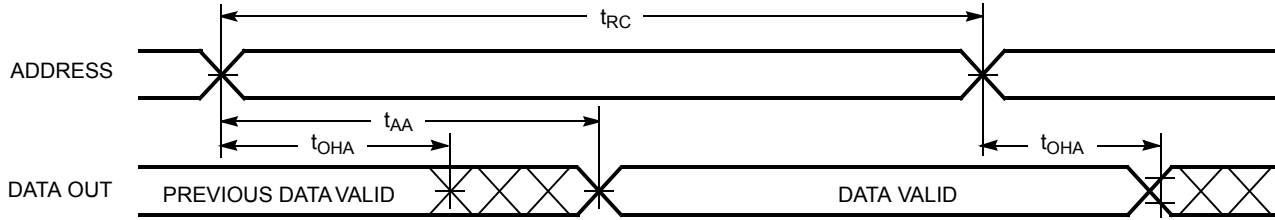
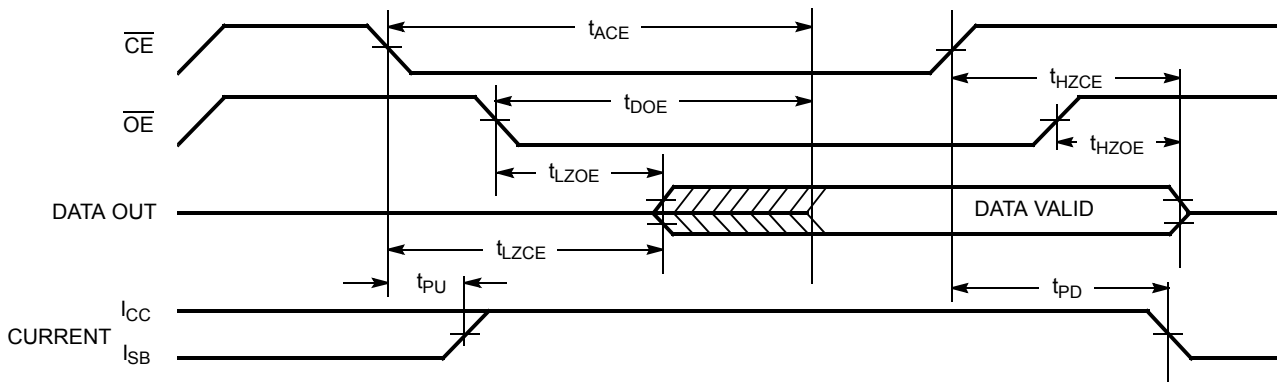
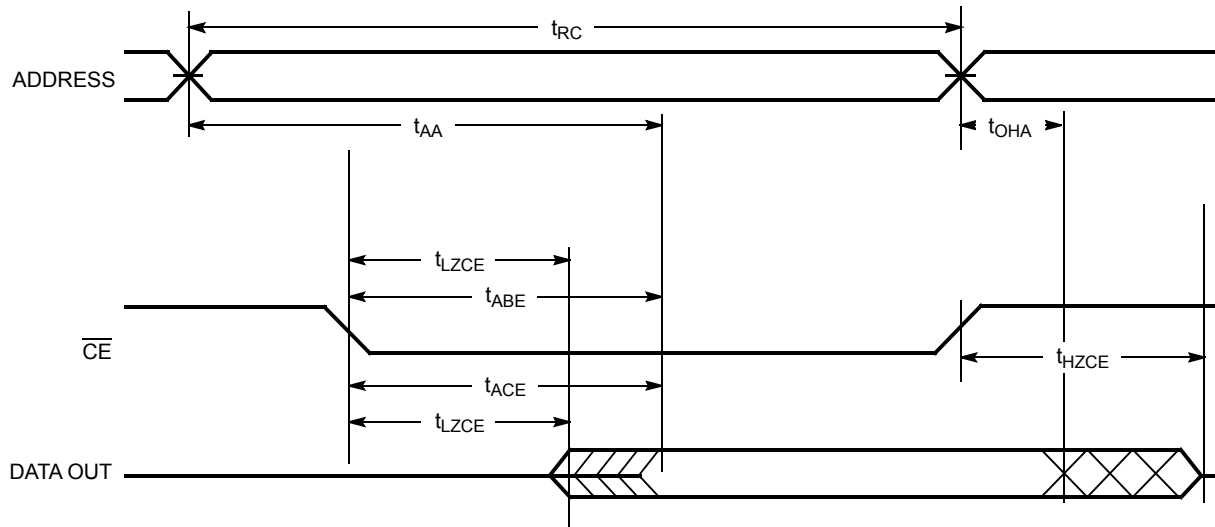
Switching Waveforms
Read Cycle No. 1 (Either Port Address Access)^[24, 25, 26]

Read Cycle No. 2 (Either Port $\overline{CE}/\overline{OE}$ Access)^[24, 27, 28]

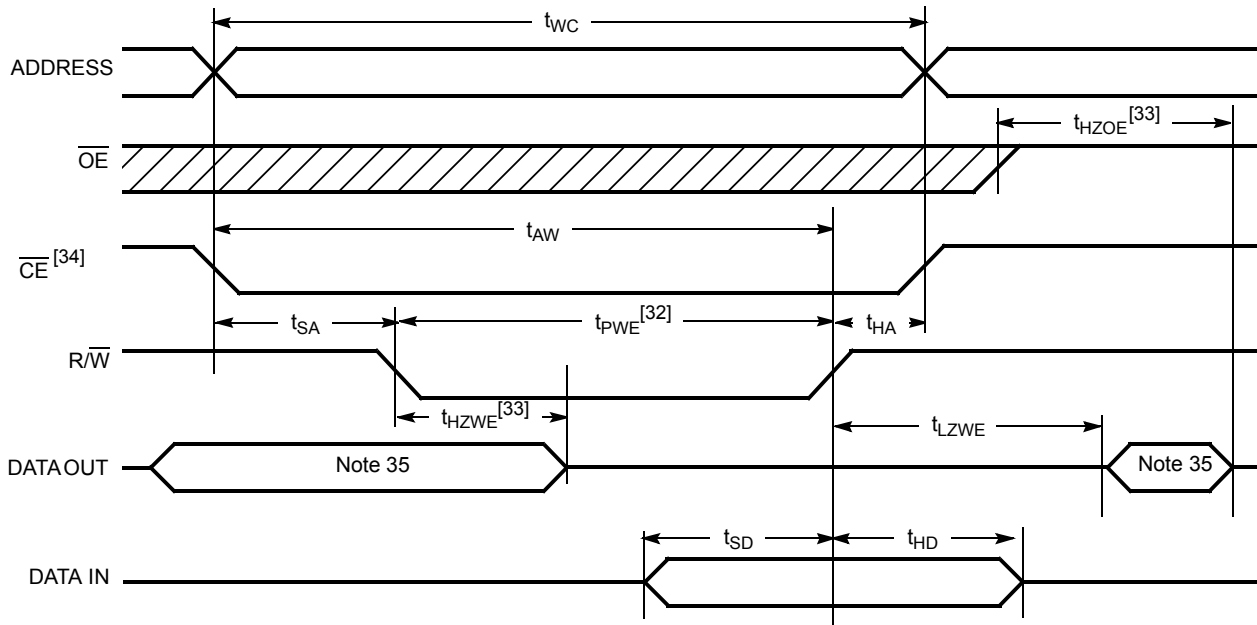
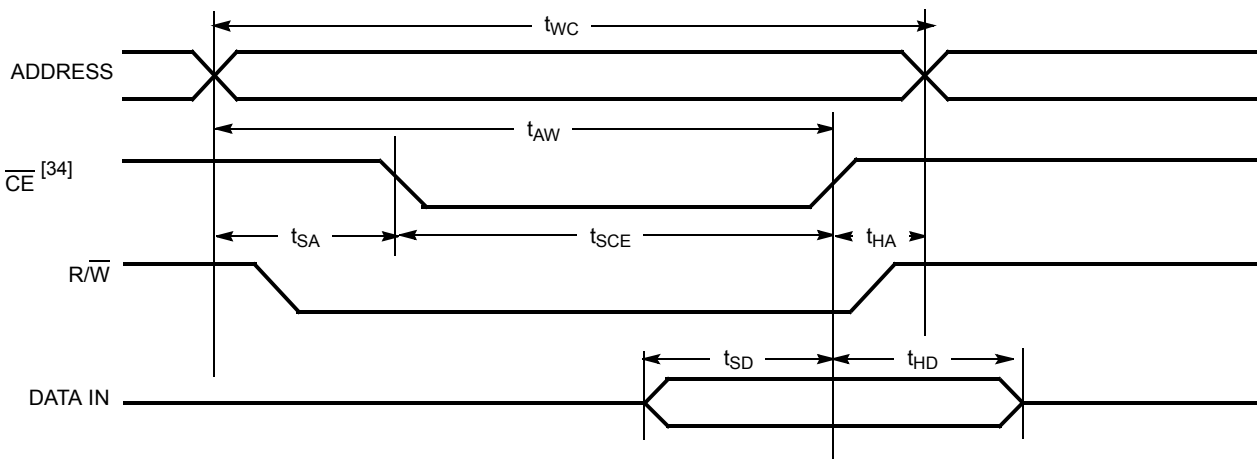
Read Cycle No. 3 (Either Port)^[24, 26, 27, 28]

Notes:

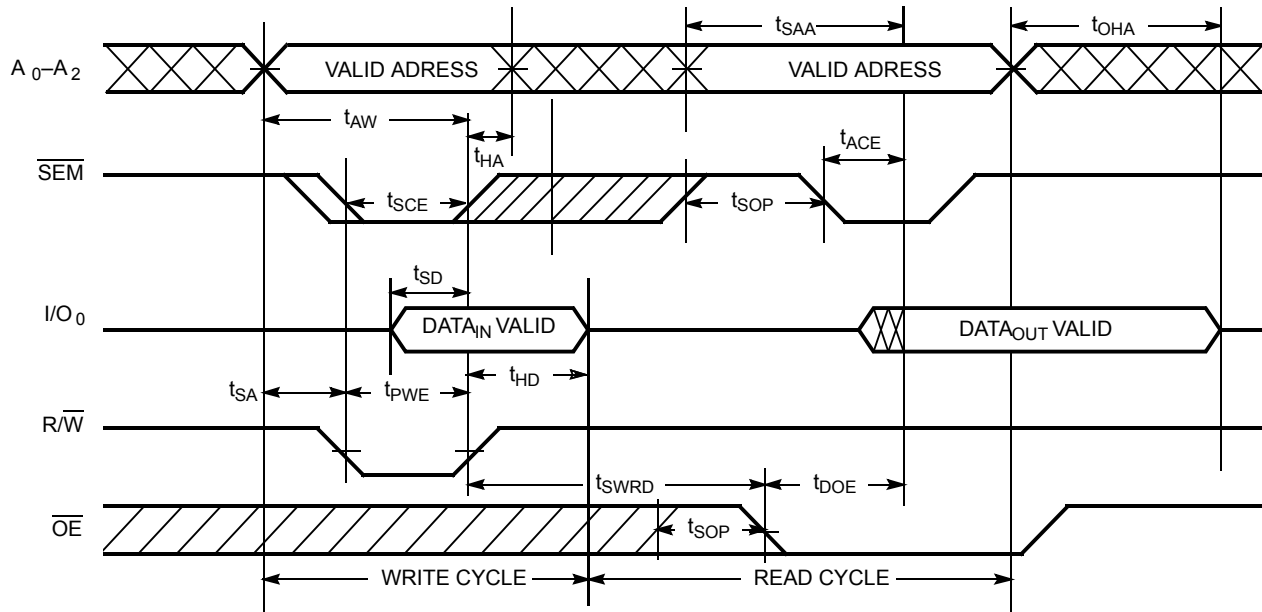
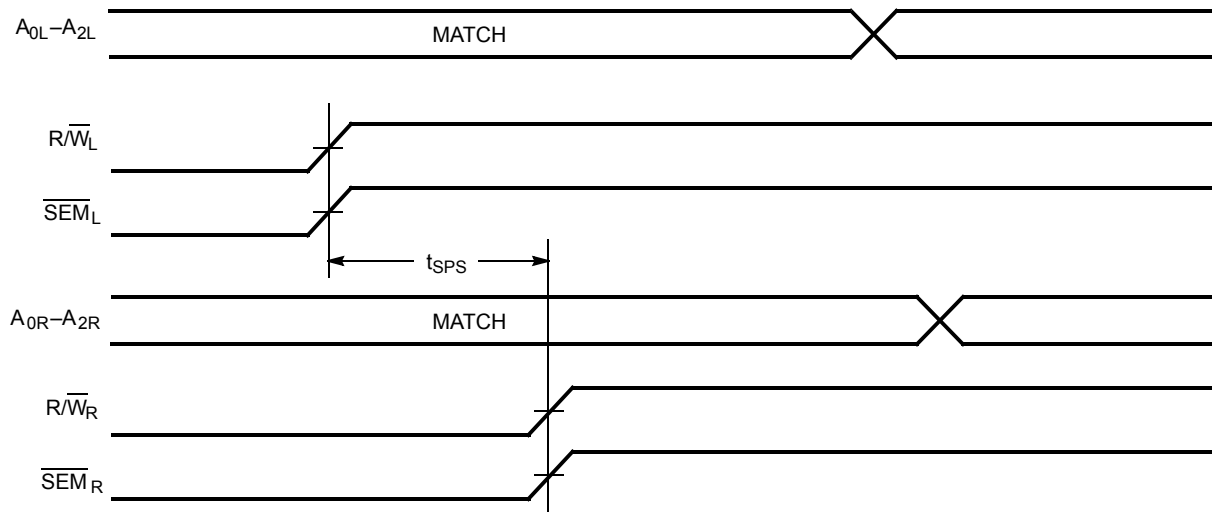
- 24. R/W is HIGH for read cycles.
- 25. Device is continuously selected $\overline{CE} = V_{IL}$. This waveform cannot be used for semaphore reads.
- 26. $OE = V_{IL}$.
- 27. Address valid prior to or coincident with \overline{CE} transition LOW.
- 28. To access RAM, $\overline{CE} = V_{IL}$, $\overline{SEM} = V_{IH}$. To access semaphore, $\overline{CE} = V_{IH}$, $\overline{SEM} = V_{IL}$.

Switching Waveforms (continued)
Write Cycle No. 1: R/W Controlled Timing^[29, 30, 31, 32]

Write Cycle No. 2: CE Controlled Timing^[29, 30, 31, 36]

Notes:

29. R/W must be HIGH during all address transitions.
30. A write occurs during the overlap (t_{SCE} or t_{PWE}) of a LOW \overline{CE} or \overline{SEM} .
31. t_{HA} is measured from the earlier of CE or R/W or (SEM or R/W) going HIGH at the end of write cycle.
32. If OE is LOW during a R/W controlled write cycle, the write pulse width must be the larger of t_{PWE} or ($t_{HZWE} + t_{SD}$) to allow the I/O drivers to turn off and data to be placed on the bus for the required t_{SD} . If OE is HIGH during an R/W controlled write cycle, this requirement does not apply and the write pulse can be as short as the specified t_{PWE} .
33. Transition is measured ± 500 mV from steady state with a 5-pF load (including scope and jig). This parameter is sampled and not 100% tested.
34. To access RAM, $CE = V_{IL}$, $SEM = V_{IH}$.
35. During this period, the I/O pins are in the output state, and input signals must not be applied.
36. If the CE or SEM LOW transition occurs simultaneously with or after the R/W LOW transition, the outputs remain in the high-impedance state.

Switching Waveforms (continued)
Semaphore Read After Write Timing, Either Side^[37]

Timing Diagram of Semaphore Contention^[38, 39, 40]

Notes:

37. CE = HIGH for the duration of the above timing (both write and read cycle).

38. I/O_{0R} = I/O_{0L} = LOW (request semaphore); CE_R = CE_L = HIGH.

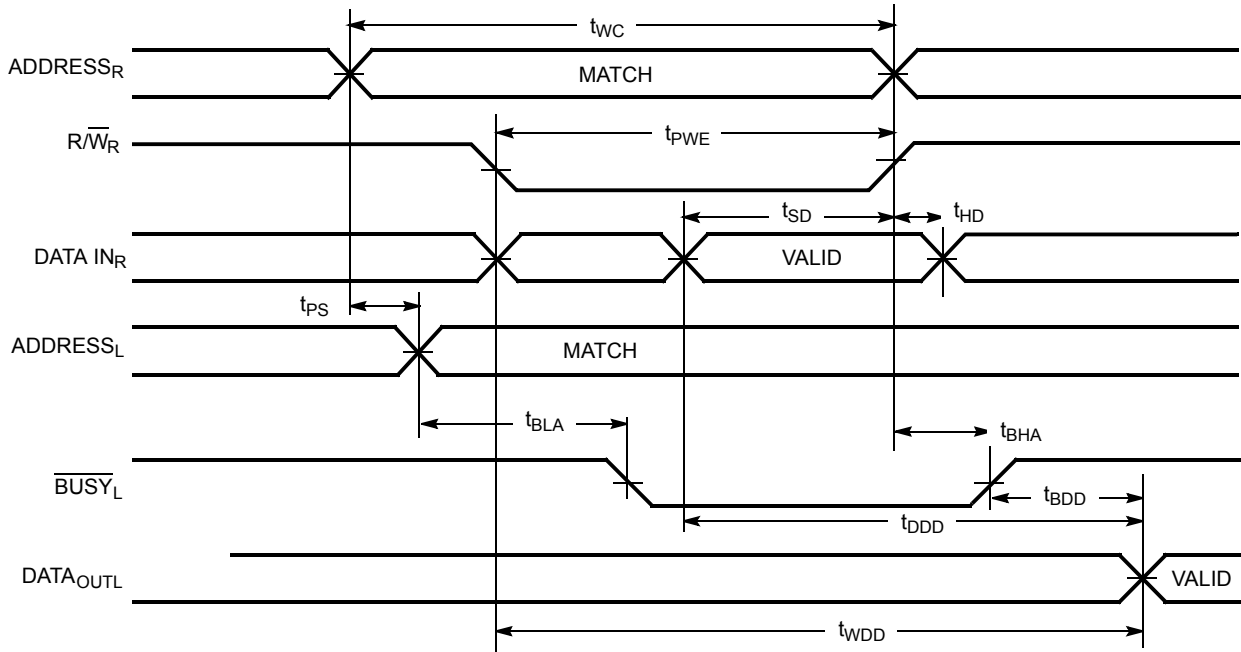
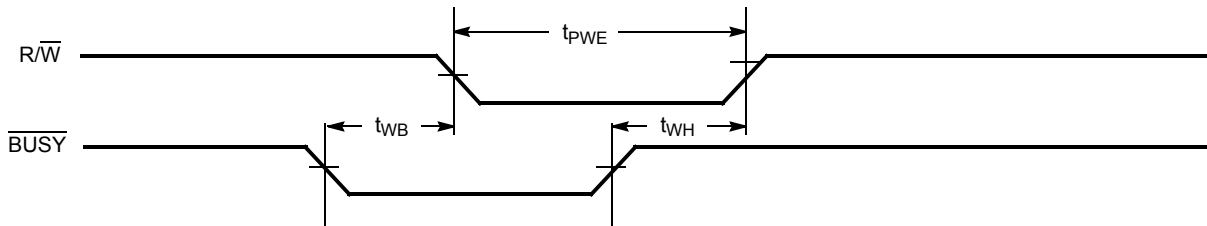
39. Semaphores are reset (available to both ports) at cycle start.

40. If t_{SPS} is violated, the semaphore will definitely be obtained by one side or the other, but which side will get the semaphore is unpredictable.

Switching Waveforms (continued)
Timing Diagram of Read with $\overline{\text{BUSY}}$ ($\overline{\text{M/S}}=\text{HIGH}$)^[41]

Write Timing with Busy Input ($\overline{\text{M/S}}=\text{LOW}$)

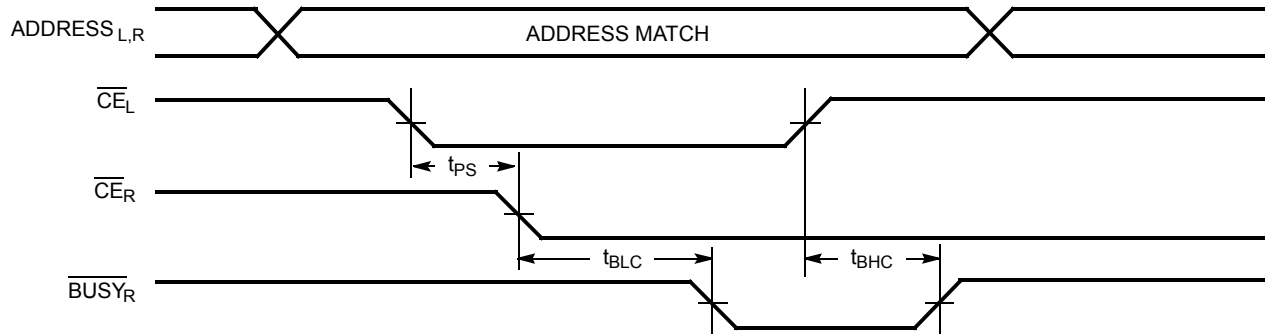
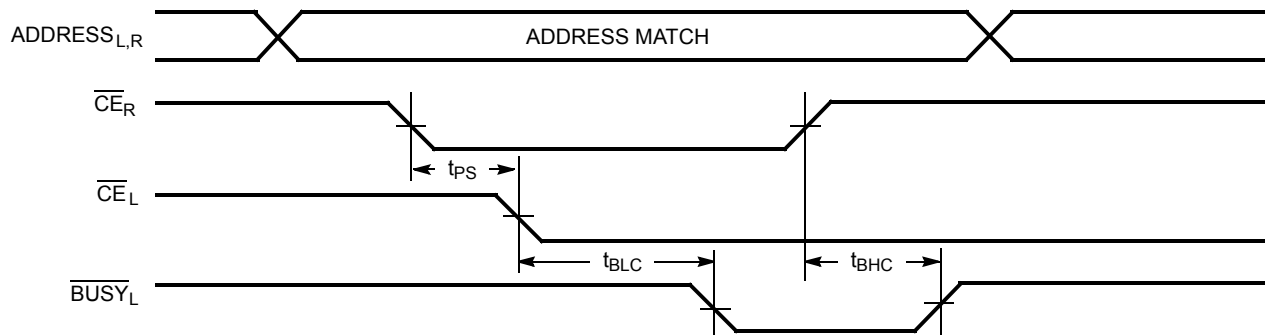
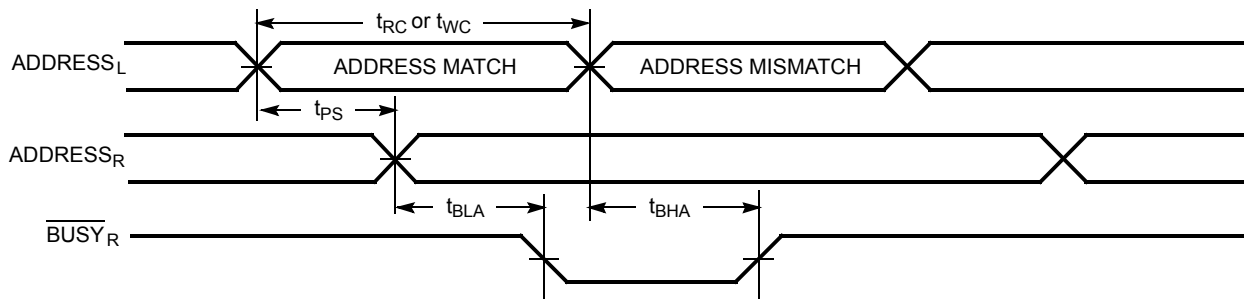
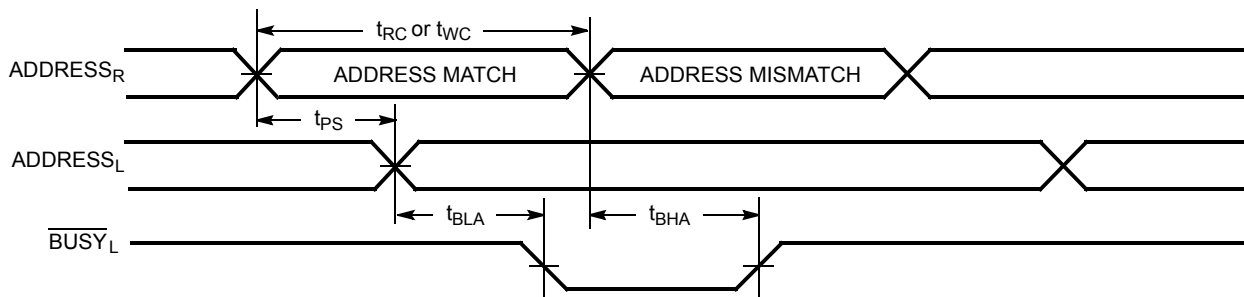
Note:
 41. $\overline{\text{CE}}_L = \overline{\text{CE}}_R = \text{LOW}$.

Switching Waveforms (continued)
Busy Timing Diagram No. 1 (\overline{CE} Arbitration)^[42]
 \overline{CE}_L Valid First:

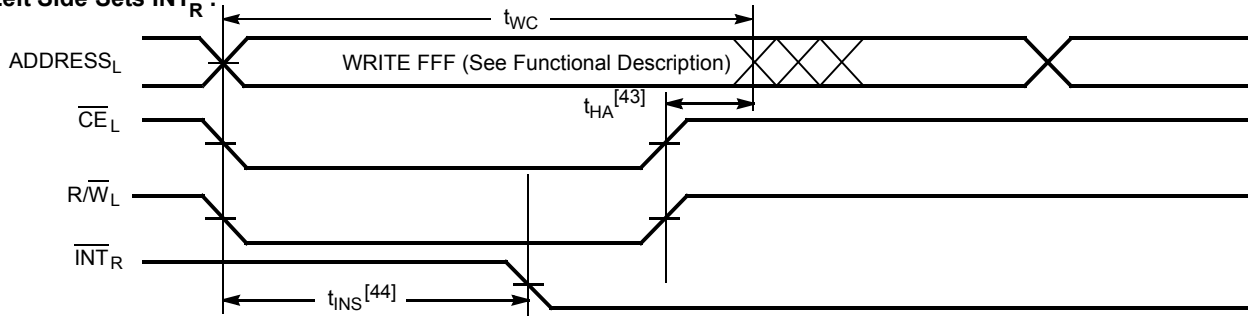
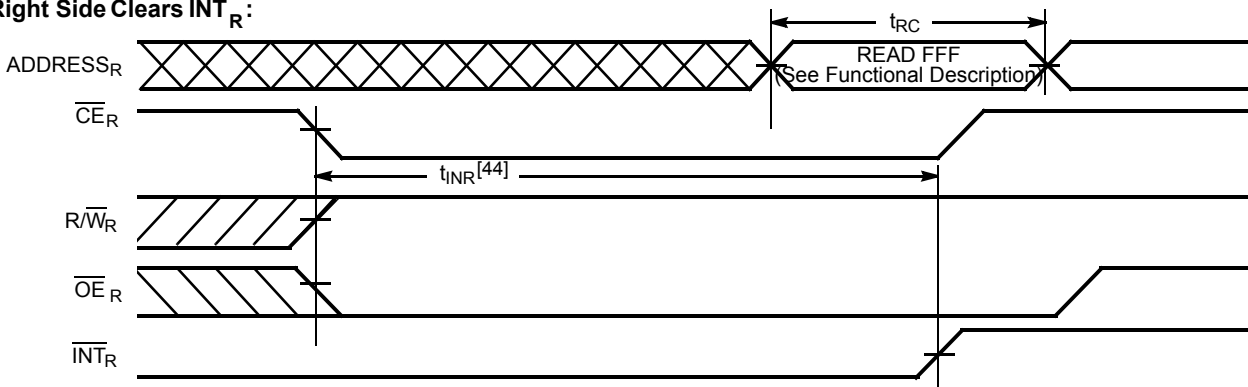
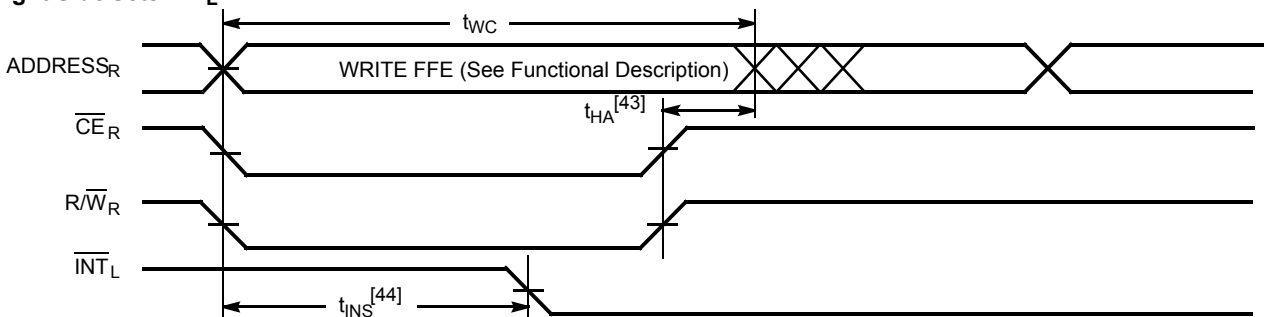
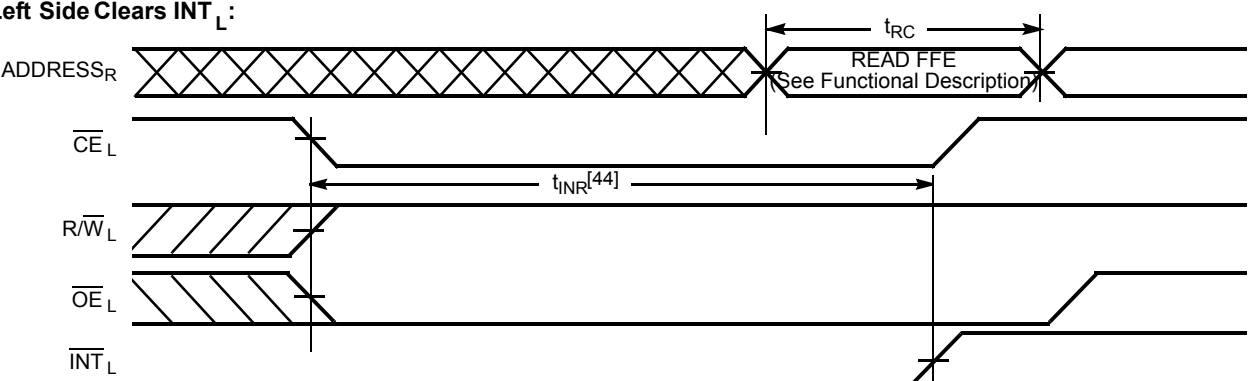
 \overline{CE}_R Valid First:

Busy Timing Diagram No. 2 (Address Arbitration)^[42]
Left Address Valid First

Right Address Valid First:

Note:

42. If t_{PS} is violated, the busy signal will be asserted on one side or the other, but there is no guarantee to which side \overline{BUSY} will be asserted.

Switching Waveforms (continued)
Interrupt Timing Diagrams
Left Side Sets \overline{INT}_R :

Right Side Clears \overline{INT}_R :

Right Side Sets \overline{INT}_L :

Left Side Clears \overline{INT}_L :

Notes:

- 43. t_{HA} depends on which enable pin (\overline{CE}_L or R/\overline{W}_L) is deasserted first.
- 44. t_{INS} or t_{INR} depends on which enable pin (\overline{CE}_L or R/\overline{W}_L) is asserted last.

Table 1. Non-Contending Read/Write

Inputs				Outputs	Operation
CE	R/W	OE	SEM	I/O ₀ -I/O ₈	
H	X	X	H	High Z	Deselected: Power-Down
H	H	L	L	Data Out	Read Data in Semaphore Flag
X	X	H	X	High Z	I/O Lines Disabled
H		X	L	Data In	Write into Semaphore Flag
L	H	L	H	Data Out	Read
L	L	X	H	Data In	Write
L	X	X	L		Not Allowed

Table 2. Interrupt Operation Example (assumes $\overline{\text{BUSY}}_L = \overline{\text{BUSY}}_R = \text{HIGH}$)

Function	Left Port					Right Port				
	R/W _L	CE _L	OE _L	A _{0L-14L}	INT _L	R/W _R	CE _R	OE _R	A _{0R-14R}	INT _R
Set Right $\overline{\text{INT}}_R$ Flag	L	L	X	FFF ^[45]	X	X	X	X	X	L ^[46]
Reset Right $\overline{\text{INT}}_R$ Flag	X	X	X	X	X	X	L	L	FFF ^[45]	H ^[47]
Set Left $\overline{\text{INT}}_L$ Flag	X	X	X	X	L ^[47]	L	L	X	1FFE ^[45]	X
Reset Left $\overline{\text{INT}}_L$ Flag	X	L	L	1FFE ^[45]	H ^[46]	X	X	X	X	X

Table 3. Semaphore Operation Example

Function	I/O ₀ -I/O ₈ Left	I/O ₀ -I/O ₈ Right	Status
No action	1	1	Semaphore free
Left port writes 0 to semaphore	0	1	Left Port has semaphore token
Right port writes 0 to semaphore	0	1	No change. Right side has no write access to semaphore
Left port writes 1 to semaphore	1	0	Right port obtains semaphore token
Left port writes 0 to semaphore	1	0	No change. Left port has no write access to semaphore
Right port writes 1 to semaphore	0	1	Left port obtains semaphore token
Left port writes 1 to semaphore	1	1	Semaphore free
Right port writes 0 to semaphore	1	0	Right port has semaphore token
Right port writes 1 to semaphore	1	1	Semaphore free
Left port writes 0 to semaphore	0	1	Left port has semaphore token
Left port writes 1 to semaphore	1	1	Semaphore free

Note:

45. See Functional Description for specific addresses by device part number.

 46. If $\overline{\text{BUSY}}_L = L$, then no change.

 47. If $\overline{\text{BUSY}}_R = L$, then no change.

Ordering Information
Package Availability Guide

Device	Organization	68-Pin PLCC	64-Pin TQFP
CY7C138AV	4K x 8	X	
CY7C139AV	4K x 9	X	
CY7C144AV	8K x 8	X	X
CY7C145AV	8K x 9	X	
CY7C006AV	16K x 8	X	X
CY7C016AV	16K x 9	X	
CY7C007AV	32K x 8	X	
CY7C017AV	32K x 9	X	

4K x8 3.3V Asynchronous Dual-Port SRAM

Speed (ns)	Ordering Code	Package Name	Package Type	Operating Range
20	CY7C138AV-20JC	J81	68-Pin Plastic Leaded Chip Carrier	Commercial
25	CY7C138AV-25JC	J81	68-Pin Plastic Leaded Chip Carrier	Commercial

4K x9 3.3V Asynchronous Dual-Port SRAM

Speed (ns)	Ordering Code	Package Name	Package Type	Operating Range
20	CY7C139AV-20JC	J81	68-Pin Plastic Leaded Chip Carrier	Commercial
25	CY7C139AV-25JC	J81	68-Pin Plastic Leaded Chip Carrier	Commercial

8K x8 3.3V Asynchronous Dual-Port SRAM

Speed (ns)	Ordering Code	Package Name	Package Type	Operating Range
20	CY7C144AV-20AC	A65	64-Pin Thin Quad Flat Pack	Commercial
	CY7C144AV-20JC	J81	68-Pin Plastic Leaded Chip Carrier	
25	CY7C144AV-25AC	A65	64-Pin Thin Quad Flat Pack	Commercial
	CY7C144AV-25AXC	A65	64-Pin Pb-Free Thin Quad Flat Pack	
	CY7C144AV-25JC	J81	68-Pin Plastic Leaded Chip Carrier	
	CY7C144AV-25JXC	J81	68-Pin Pb-Free Plastic Leaded Chip Carrier	

8K x9 3.3V Asynchronous Dual-Port SRAM

Speed (ns)	Ordering Code	Package Name	Package Type	Operating Range
20	CY7C145AV-20JC	J81	68-Pin Plastic Leaded Chip Carrier	Commercial
25	CY7C145AV-25JC	J81	68-Pin Plastic Leaded Chip Carrier	Commercial

16K x8 3.3V Asynchronous Dual-Port SRAM

Speed (ns)	Ordering Code	Package Name	Package Type	Operating Range
20	CY7C006AV-20AC	A65	64-Pin Thin Quad Flat Pack	Commercial
	CY7C006AV-20JC	J81	68-Pin Plastic Leaded Chip Carrier	
25	CY7C006AV-25AC	A65	64-Pin Thin Quad Flat Pack	Commercial
	CY7C006AV-25AXC	A65	64-Pin Pb-Free Thin Quad Flat Pack	
	CY7C006AV-25JC	J81	68-Pin Plastic Leaded Chip Carrier	



Ordering Information (continued)

16K x9 3.3V Asynchronous Dual-Port SRAM

Speed (ns)	Ordering Code	Package Name	Package Type	Operating Range
20	CY7C016AV-20JC	J81	68-Pin Plastic Leaded Chip Carrier	Commercial
25	CY7C016AV-25JC	J81	68-Pin Plastic Leaded Chip Carrier	Commercial

32K x8 3.3V Asynchronous Dual-Port SRAM

Speed (ns)	Ordering Code	Package Name	Package Type	Operating Range
20	CY7C007AV-20JC	J81	68-Pin Plastic Leaded Chip Carrier	Commercial
	CY7C007AV-20JI	J81	68-Pin Plastic Leaded Chip Carrier	Industrial
25	CY7C007AV-25JC	J81	68-Pin Plastic Leaded Chip Carrier	Commercial

32K x9 3.3V Asynchronous Dual-Port SRAM

Speed (ns)	Ordering Code	Package Name	Package Type	Operating Range
20	CY7C017AV-20JC	J81	68-Pin Plastic Leaded Chip Carrier	Commercial
	CY7C017AV-20JI	J81	68-Pin Plastic Leaded Chip Carrier	Industrial
25	CY7C017AV-25JC	J81	68-Pin Plastic Leaded Chip Carrier	Commercial

Package Diagrams

64-Lead Thin Plastic Quad Flat Pack (14 x 14 x 1.4 mm) A65
64-Lead Pb-Free Thin Plastic Quad Flat Pack (14 x 14 x 1.4mm) A65

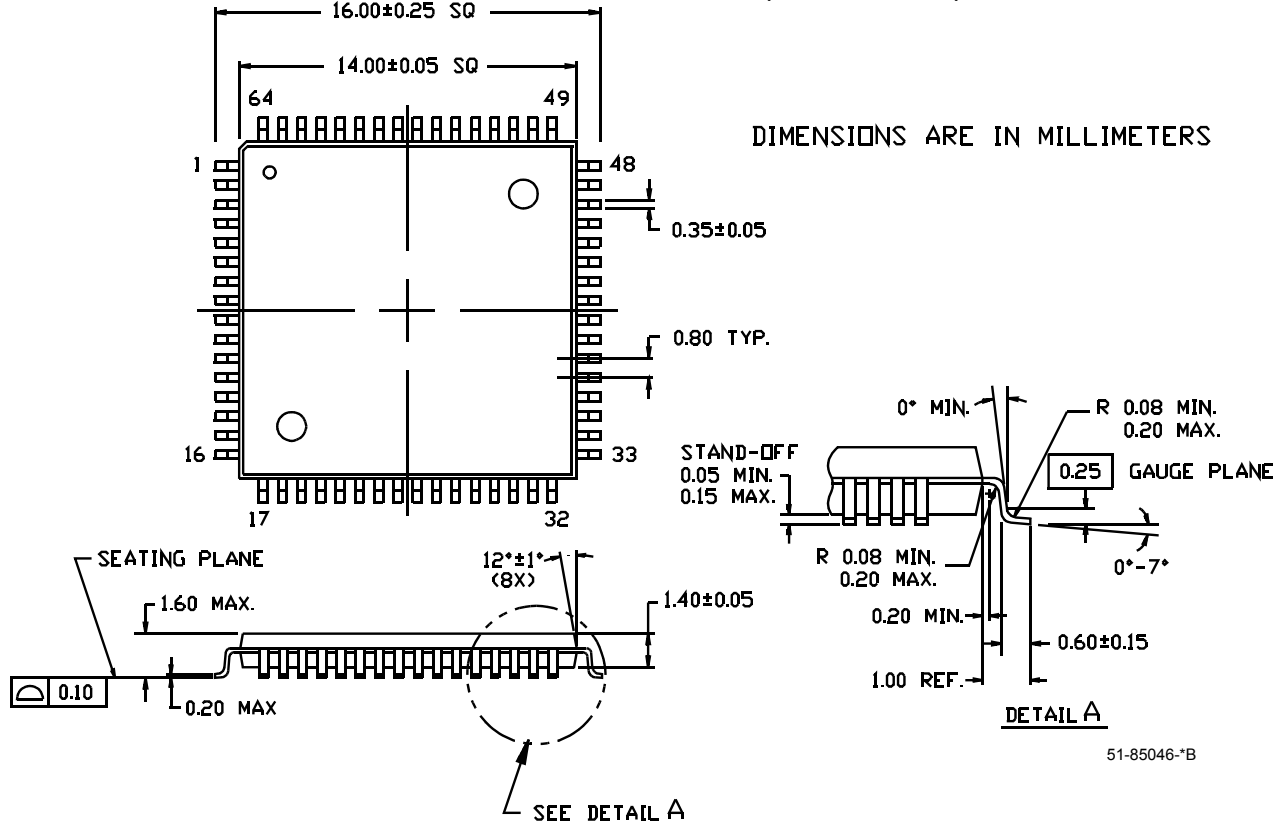

68-Lead Plastic Leaded Chip Carrier J81
68-Lead Pb-Free Plastic Leaded Chip Carrier J81

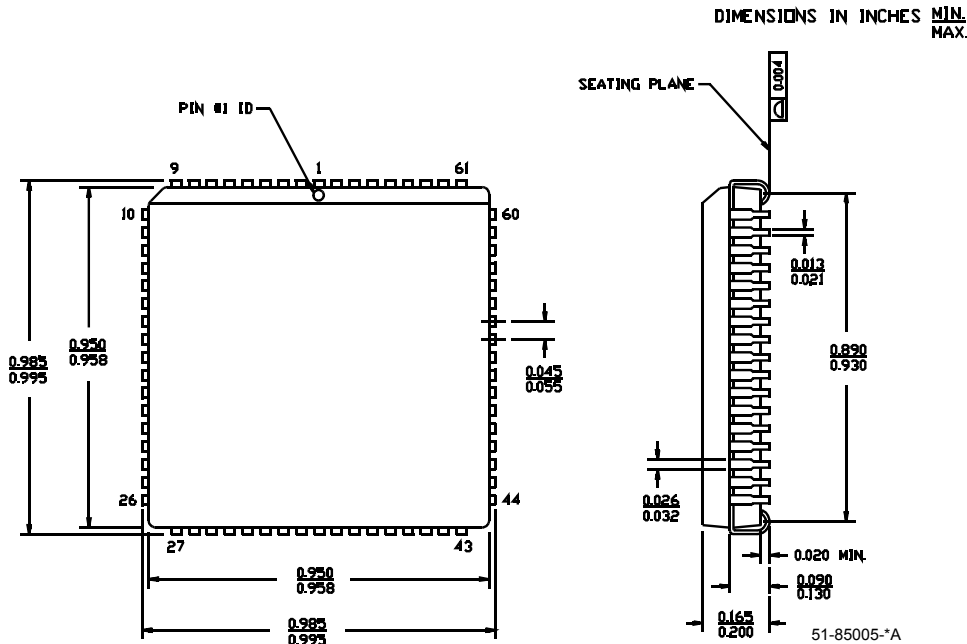

All products and company names mentioned in this document may be the trademarks of their respective holders.

Document History Page

Document Title: CY7C138AV/144AV/006AV/CY7C139AV/145AV/016AV/CY7C007AV/017AV 3.3V 4K/8K/16K/32K x 8/9 Dual Port SRAM				
Document Number: 38-06051				
REV.	ECN NO.	Issue Date	Orig. of Change	Description of Change
**	110203	12/02/01	SZV	Change from Spec number: 38-00837 to 38-06051
*A	122301	12/27/02	RBI	Power up requirements added to Maximum Ratings Information
*B	237623	See ECN	YDT	Removed cross information from features section
*C	373615	See ECN	PCX	Added Pb-Free Logo Added Pb-Free parts to ordering information: CY7C144AV-25AXC, CY7C144AV-25JXC, CY7C006AV-25AXC