



CY7C09079V/89V/99V
CY7C09179V/89V/99V

3.3V 32K/64K/128K x 8/9 Synchronous Dual-Port Static RAM

Features

- True Dual-Ported memory cells which allow simultaneous access of the same memory location
- 6 Flow-Through/Pipelined devices
 - 32K x 8/9 organizations (CY7C09079V/179V)
 - 64K x 8/9 organizations (CY7C09089V/189V)
 - 128K x 8/9 organizations (CY7C09099V/199V)
- 3 Modes
 - Flow-Through
 - Pipelined
 - Burst
- Pipelined output mode on both ports allows fast 100-MHz operation
- 0.35-micron CMOS for optimum speed/power
- High-speed clock to data access 6.5^[1]/7.5^[1]/9/12 ns (max.)
- 3.3V low operating power
 - Active= 115 mA (typical)
 - Standby= 10 μ A (typical)
- Fully synchronous interface for easier operation
- Burst counters increment addresses internally
 - Shorten cycle times
 - Minimize bus noise
 - Supported in Flow-Through and Pipelined modes
- Dual Chip Enables for easy depth expansion
- Automatic power-down
- Commercial and Industrial temperature ranges
- Available in 100-pin TQFP
- Pb-Free packages available

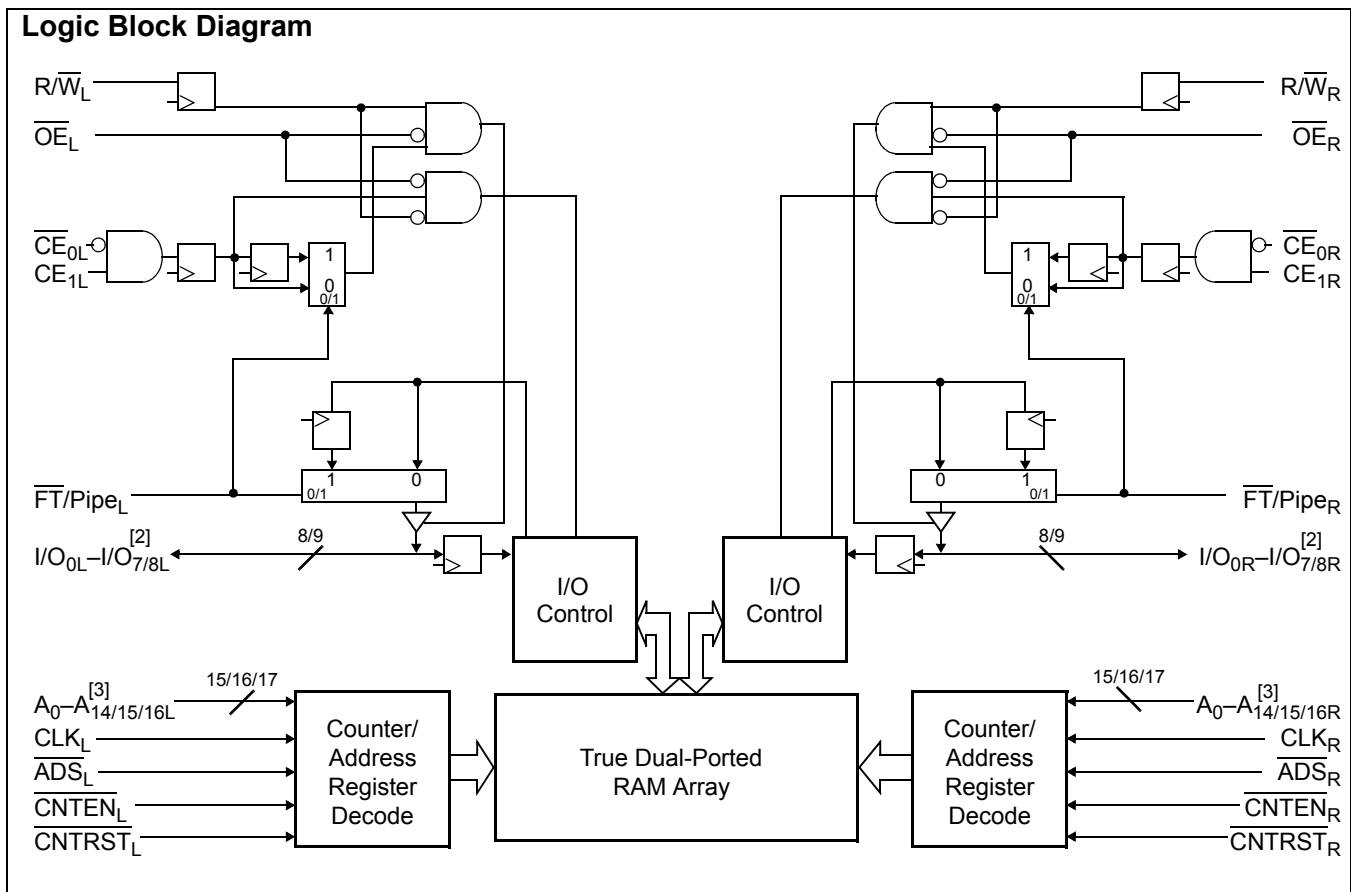

Notes:

1. See page 6 for Load Conditions.
2. I/O₀-I/O₇ for x8 devices, I/O₀-I/O₈ for x9 devices.
3. A₀-A₁₄ for 32K, A₀-A₁₅ for 64K, and A₀-A₁₆ for 128K devices.

Functional Description

The CY7C09079V/89V/99V and CY7C09179V/89V/99V are high-speed synchronous CMOS 32K, 64K, and 128K x 8/9 dual-port static RAMs. Two ports are provided, permitting independent, simultaneous access for reads and writes to any location in memory.^[4] Registers on control, address, and data lines allow for minimal set-up and hold times. In pipelined output mode, data is registered for decreased cycle time. Clock to data valid $t_{CD2} = 6.5 \text{ ns}^{[1]}$ (pipelined). Flow-through mode can also be used to bypass the pipelined output register to eliminate access latency. In flow-through mode data will be available $t_{CD1} = 18 \text{ ns}$ after the address is clocked into the device. Pipelined output or flow-through mode is selected via the FT/Pipe pin.

Each port contains a burst counter on the input address register. The internal write pulse width is independent of the LOW-to-HIGH transition of the clock signal. The internal write pulse is self-timed to allow the shortest possible cycle times.

A HIGH on \overline{CE}_0 or LOW on CE_1 for one clock cycle will power down the internal circuitry to reduce the static power consumption. The use of multiple Chip Enables allows easier banking of multiple chips for depth expansion configurations. In the pipelined mode, one cycle is required with CE_0 LOW and CE_1 HIGH to reactivate the outputs.

Counter enable inputs are provided to stall the operation of the address input and utilize the internal address generated by the internal counter for fast interleaved memory applications. A port's burst counter is loaded with the port's Address Strobe (ADS). When the port's Count Enable (CNTEN) is asserted, the address counter will increment on each LOW-to-HIGH transition of that port's clock signal. This will read/write one word from/into each successive address location until CNTEN is deasserted. The counter can address the entire memory array and will loop back to the start. Counter Reset (CNTRST) is used to reset the burst counter.

All parts are available in 100-pin Thin Quad Plastic Flatpack (TQFP) packages.

Pin Configurations

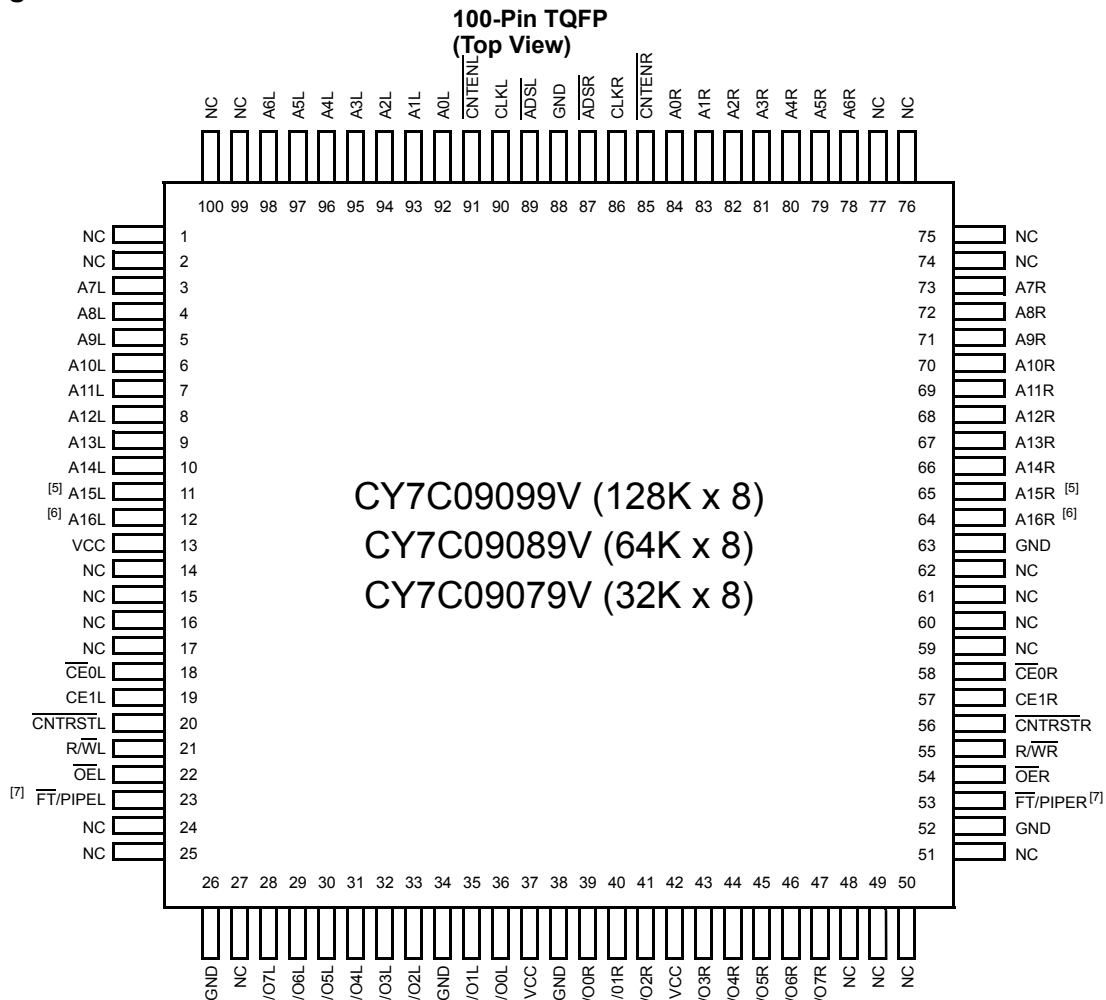

Notes:

4. When writing simultaneously to the same location, the final value cannot be guaranteed.
5. This pin is NC for CY7C09079V.
6. This pin is NC for CY7C09079V and CY7C09089V.
7. For CY7C09079V and CY7C09089V, pin #23 connected to V_{CC} is pin compatible with an IDT 5V x8 pipelined device; connecting pin #23 and #53 to GND is pin compatible with an IDT 5V x16 flow-through device.

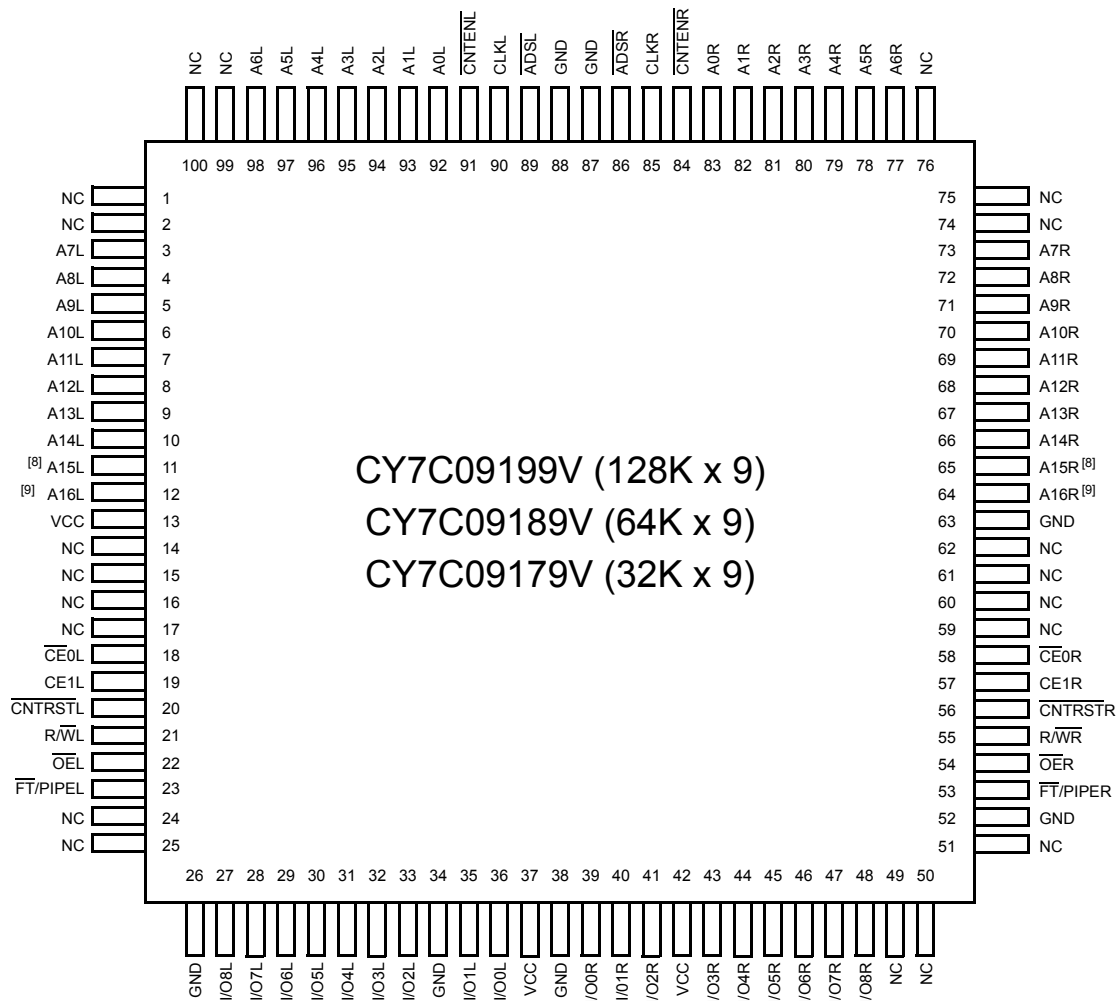
Pin Configurations (continued)
**100-Pin TQFP
(Top View)**

Selection Guide

| | CY7C09079V/89V/99V CY7C09179V/89V/99V -6 ^[1] | CY7C09079V/89V/99V CY7C09179V/89V/99V -7 ^[1] | CY7C09079V/89V/99V CY7C09179V/89V/99V -9 | CY7C09079V/89V/99V CY7C09179V/89V/99V -12 |
|---|---|---|--|---|
| f _{MAX2} (MHz) (Pipelined) | 100 | 83 | 67 | 50 |
| Max. Access Time (ns) (Clock to Data, Pipelined) | 6.5 | 7.5 | 9 | 12 |
| Typical Operating Current I _{CC} (mA) | 175 | 155 | 135 | 115 |
| Typical Standby Current for I _{SB1} (mA) (Both Ports TTL Level) | 25 | 25 | 20 | 20 |
| Typical Standby Current for I _{SB3} (μA) (Both Ports CMOS Level) | 10 μA | 10 μA | 10 μA | 10 μA |

Notes:

8. This pin is NC for CY7C09179V.

9. This pin is NC for CY7C09179V and CY7C09189V.

Pin Definitions

| Left Port | Right Port | Description |
|--------------------------------------|--------------------------------------|--|
| A _{0L} -A _{16L} | A _{0R} -A _{16R} | Address Inputs (A ₀ -A ₁₄ for 32K; A ₀ -A ₁₅ for 64K; and A ₀ -A ₁₆ for 128K devices). |
| ADS _L | ADS _R | Address Strobe Input. Used as an address qualifier. This signal should be asserted LOW to access the part using an externally supplied address. Asserting this signal LOW also loads the burst counter with the address present on the address pins. |
| $\overline{CE}_{0L}, CE_{1L}$ | $\overline{CE}_{0R}, CE_{1R}$ | Chip Enable Input. To select either the left or right port, both \overline{CE}_0 AND CE_1 must be asserted to their active states ($\overline{CE}_0 \leq V_{IL}$ and $CE_1 \geq V_{IH}$). |
| CLK _L | CLK _R | Clock Signal. This input can be free running or strobed. Maximum clock input rate is f_{MAX} . |
| CNTEN _L | CNTEN _R | Counter Enable Input. Asserting this signal <u>LOW</u> increments the <u>burst address counter</u> of its respective port on each rising edge of CLK. CNTEN is disabled if ADS or CNTRST are asserted LOW. |
| CNTRST _L | CNTRST _R | Counter Reset Input. Asserting this signal <u>LOW</u> <u>resets</u> the <u>burst address counter</u> of its respective port to zero. CNTRST is not disabled by asserting ADS or CNTEN. |
| I/O _{0L} -I/O _{8L} | I/O _{0R} -I/O _{8R} | Data Bus Input/Output (I/O ₀ -I/O ₇ for x8 devices; I/O ₀ -I/O ₈ for x9 devices). |
| \overline{OE}_L | \overline{OE}_R | Output Enable Input. This signal must be asserted LOW to enable the I/O data pins during read operations. |
| R/W _L | R/W _R | Read/Write Enable Input. This signal is asserted LOW to write to the dual port memory array. For read operations, assert this pin HIGH. |
| $\overline{FT}/PIPE_L$ | $\overline{FT}/PIPE_R$ | Flow-Through/Pipelined Select Input. For flow-through mode operation, assert this pin LOW. For pipelined mode operation, assert this pin HIGH. |
| GND | | Ground Input. |
| NC | | No Connect. |
| V _{CC} | | Power Input. |

Maximum Ratings^[10]

(Above which the useful life may be impaired. For user guidelines, not tested.)

Storage Temperature -65°C to +150°C

Ambient Temperature with Power Applied ..-55°C to +125°C

Supply Voltage to Ground Potential -0.5V to +4.6V

DC Voltage Applied to

Outputs in High Z State-0.5V to V_{CC}+0.5V

DC Input Voltage-0.5V to V_{CC}+0.5V

Output Current into Outputs (LOW)..... 20 mA

Static Discharge Voltage..... >2001V

Latch-Up Current..... >200 mA

Operating Range

| Range | Ambient Temperature | V _{CC} |
|----------------------------|---------------------|-----------------|
| Commercial | 0°C to +70°C | 3.3V ± 300 mV |
| Industrial ^[11] | -40°C to +85°C | 3.3V ± 300 mV |

Notes:

10. The Voltage on any input or I/O pin cannot exceed the power pin during power-up.

11. Industrial parts are available in CY7C09099V and CY7C09199V only.

Electrical Characteristics Over the Operating Range

| Parameter | Description | CY7C09079V/89V/99V CY7C09179V/89V/99V | | | | | | | | | | | | Unit |
|------------------|---|--|------|------|-------------------|------|------|------|------|------|------|------|------|------|
| | | -6 ^[1] | | | -7 ^[1] | | | -9 | | | -12 | | | |
| | | Min. | Typ. | Max. | Min. | Typ. | Max. | Min. | Typ. | Max. | Min. | Typ. | Max. | |
| V _{OH} | Output HIGH Voltage (V _{CC} = Min. I _{OH} = -4.0 mA) | 2.4 | | | 2.4 | | | 2.4 | | | 2.4 | | | V |
| V _{OL} | Output LOW Voltage (V _{CC} = Min. I _{OH} = +4.0 mA) | | | 0.4 | | | 0.4 | | | 0.4 | | | 0.4 | V |
| V _{IH} | Input HIGH Voltage | 2.0 | | | 2.0 | | | 2.0 | | | 2.0 | | | V |
| V _{IL} | Input LOW Voltage | | | 0.8 | | | 0.8 | | | 0.8 | | | 0.8 | V |
| I _{OZ} | Output Leakage Current | -10 | | 10 | -10 | | 10 | -10 | | 10 | -10 | | 10 | μA |
| I _{CC} | Operating Current (V _{CC} = Max. I _{OUT} = 0 mA) Outputs Disabled | Com'l. | 175 | 320 | | 155 | 275 | | 135 | 225 | | 115 | 205 | mA |
| | | Ind. ^[11] | | | | 275 | 390 | | 185 | 295 | | | | mA |
| I _{SB1} | Standby Current (Both Ports TTL Level) ^[12] CE _L CE _R ≥ V _{IH} , f = f _{MAX} | Com'l. | 25 | 95 | | 25 | 85 | | 20 | 65 | | 20 | 50 | mA |
| | | Ind. ^[11] | | | | 85 | 120 | | 35 | 75 | | | | mA |
| I _{SB2} | Standby Current (One Port TTL Level) ^[12] CE _L CE _R ≥ V _{IH} , f = f _{MAX} | Com'l. | 115 | 175 | | 105 | 165 | | 95 | 150 | | 85 | 140 | mA |
| | | Ind. ^[11] | | | | 165 | 210 | | 105 | 160 | | | | mA |
| I _{SB3} | Standby Current (Both Ports CMOS Level) ^[12] CE _L & CE _R ≥ V _{CC} - 0.2V, f = 0 | Com'l. | 10 | 250 | | 10 | 250 | | 10 | 250 | | 10 | 250 | μA |
| | | Ind. ^[11] | | | | 10 | 250 | | 10 | 250 | | | | μA |
| I _{SB4} | Standby Current (One Port CMOS Level) ^[12] CE _L CE _R ≥ V _{IH} , f = f _{MAX} | Com'l. | 105 | 135 | | 95 | 125 | | 85 | 115 | | 75 | 100 | mA |
| | | Ind. ^[11] | | | | 125 | 170 | | 95 | 125 | | | | mA |

Capacitance

| Parameter | Description | Test Conditions | Max. | Unit |
|------------------|--------------------|---|------|------|
| C _{IN} | Input Capacitance | T _A = 25°C, f = 1 MHz, V _{CC} = 3.3V | 10 | pF |
| C _{OUT} | Output Capacitance | | 10 | pF |

Note:

12. CE_L and CE_R are internal signals. To select either the left or right port, both CE₀ AND CE₁ must be asserted to their active states (CE₀ ≤ V_{IL} and CE₁ ≥ V_{IH}).

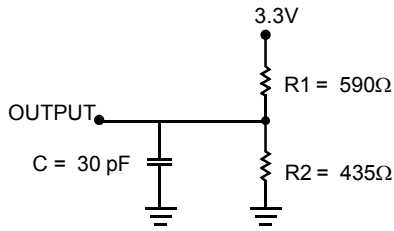
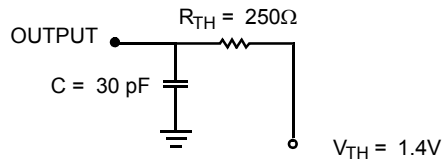
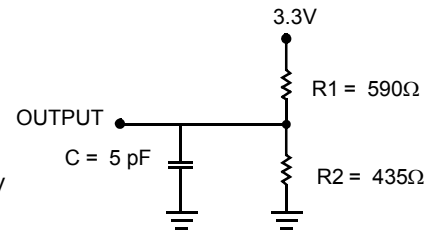
AC Test Loads

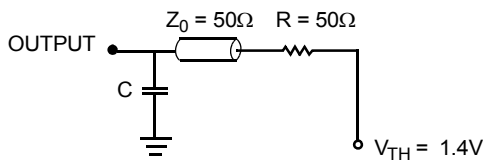
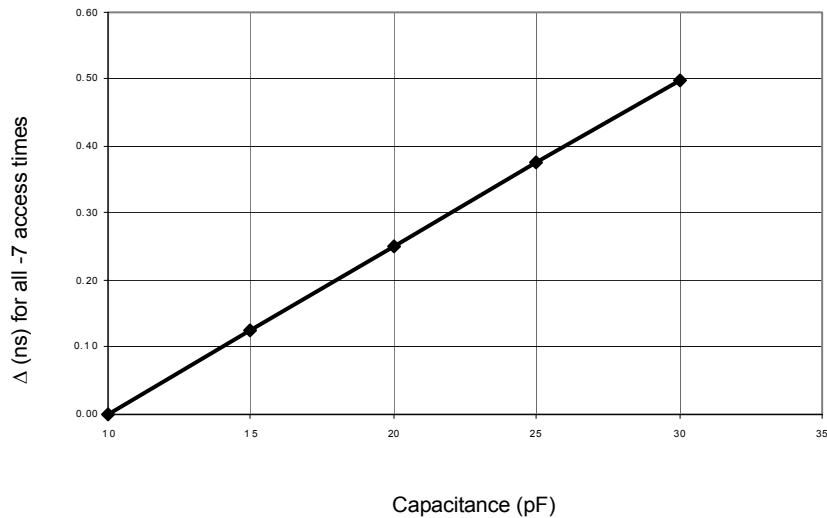
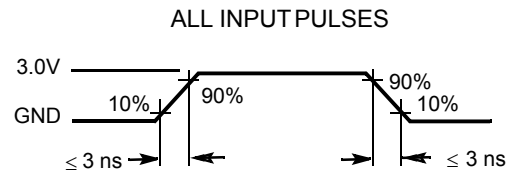
(a) Normal Load (Load 1)

(b) Thévenin Equivalent (Load 1)

(c) Three-State Delay (Load 2)
 (Used for t_{CKLZ} , t_{OLZ} , & t_{OHZ} including scope and jig)

AC Test Loads (Applicable to -6 and -7 only)^[13]

(a) Load 1 (-6 and -7 only)

(b) Load Derating Curve

Note:
 13. Test Conditions: C = 10 pF.

Switching Characteristics Over the Operating Range

| Parameter | Description | CY7C09079V/89V/99V CY7C09179V/89V/99V | | | | | | | | Unit |
|---------------------------------------|--|--|------|-------------------|------|------|------|------|------|------|
| | | -6 ^[1] | | -7 ^[1] | | -9 | | -12 | | |
| | | Min. | Max. | Min. | Max. | Min. | Max. | Min. | Max. | |
| f _{MAX1} | f _{Max} Flow-Through | | 53 | | 45 | | 40 | | 33 | MHz |
| f _{MAX2} | f _{Max} Pipelined | | 100 | | 83 | | 67 | | 50 | MHz |
| t _{CYC1} | Clock Cycle Time - Flow-Through | 19 | | 22 | | 25 | | 30 | | ns |
| t _{CYC2} | Clock Cycle Time - Pipelined | 10 | | 12 | | 15 | | 20 | | ns |
| t _{CH1} | Clock HIGH Time - Flow-Through | 6.5 | | 7.5 | | 12 | | 12 | | ns |
| t _{CL1} | Clock LOW Time - Flow-Through | 6.5 | | 7.5 | | 12 | | 12 | | ns |
| t _{CH2} | Clock HIGH Time - Pipelined | 4 | | 5 | | 6 | | 8 | | ns |
| t _{CL2} | Clock LOW Time - Pipelined | 4 | | 5 | | 6 | | 8 | | ns |
| t _R | Clock Rise Time | | 3 | | 3 | | 3 | | 3 | ns |
| t _F | Clock Fall Time | | 3 | | 3 | | 3 | | 3 | ns |
| t _{SA} | Address Set-Up Time | 3.5 | | 4 | | 4 | | 4 | | ns |
| t _{HA} | Address Hold Time | 0 | | 0 | | 1 | | 1 | | ns |
| t _{SC} | Chip Enable Set-Up Time | 3.5 | | 4 | | 4 | | 4 | | ns |
| t _{HC} | Chip Enable Hold Time | 0 | | 0 | | 1 | | 1 | | ns |
| t _{SW} | R/W Set-Up Time | 3.5 | | 4 | | 4 | | 4 | | ns |
| t _{HW} | R/W Hold Time | 0 | | 0 | | 1 | | 1 | | ns |
| t _{SD} | Input Data Set-Up Time | 3.5 | | 4 | | 4 | | 4 | | ns |
| t _{HD} | Input Data Hold Time | 0 | | 0 | | 1 | | 1 | | ns |
| t _{SAD} | ADS Set-Up Time | 3.5 | | 4 | | 4 | | 4 | | ns |
| t _{HAD} | ADS Hold Time | 0 | | 0 | | 1 | | 1 | | ns |
| t _{SCN} | CNTEN Set-Up Time | 3.5 | | 4.5 | | 5 | | 5 | | ns |
| t _{HCN} | CNTEN Hold Time | 0 | | 0 | | 1 | | 1 | | ns |
| t _{SRST} | CNTRST Set-Up Time | 3.5 | | 4 | | 4 | | 4 | | ns |
| t _{HRST} | CNTRST Hold Time | 0 | | 0 | | 1 | | 1 | | ns |
| t _{OE} | Output Enable to Data Valid | | 8 | | 9 | | 10 | | 12 | ns |
| t _{OLZ} ^[14, 15] | OE to Low Z | 2 | | 2 | | 2 | | 2 | | ns |
| t _{OHZ} ^[14, 15] | OE to High Z | 1 | 7 | 1 | 7 | 1 | 7 | 1 | 7 | ns |
| t _{CD1} | Clock to Data Valid - Flow-Through | | 15 | | 18 | | 20 | | 25 | ns |
| t _{CD2} | Clock to Data Valid - Pipelined | | 6.5 | | 7.5 | | 9 | | 12 | ns |
| t _{DC} | Data Output Hold After Clock HIGH | 2 | | 2 | | 2 | | 2 | | ns |
| t _{CKHZ} ^[14, 15] | Clock HIGH to Output High Z | 2 | 9 | 2 | 9 | 2 | 9 | 2 | 9 | ns |
| t _{CKLZ} ^[14, 15] | Clock HIGH to Output Low Z | 2 | | 2 | | 2 | | 2 | | ns |
| Port to Port Delays | | | | | | | | | | |
| t _{CWDD} | Write Port Clock HIGH to Read Data Delay | | 30 | | 35 | | 40 | | 40 | ns |
| t _{CCS} | Clock to Clock Set-Up Time | | 9 | | 10 | | 15 | | 15 | ns |

Notes:

14. Test conditions used are Load 2.

15. This parameter is guaranteed by design, but it is not production tested.

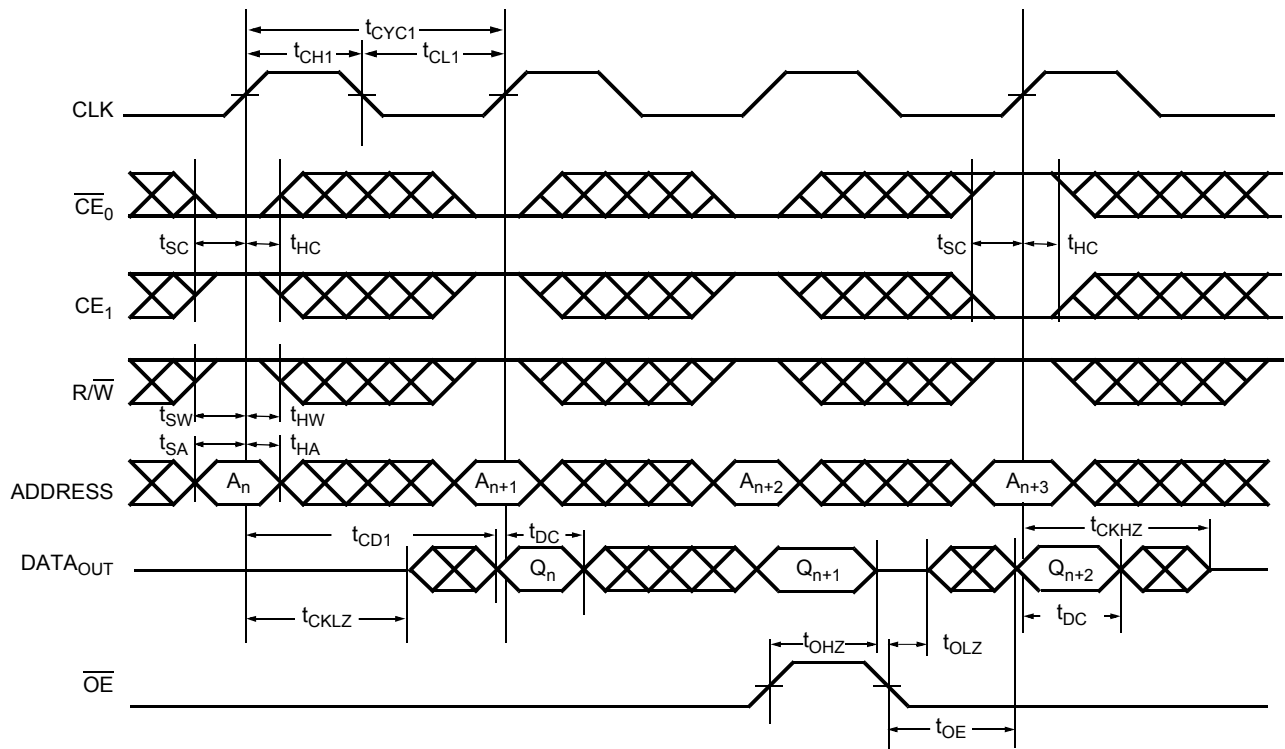
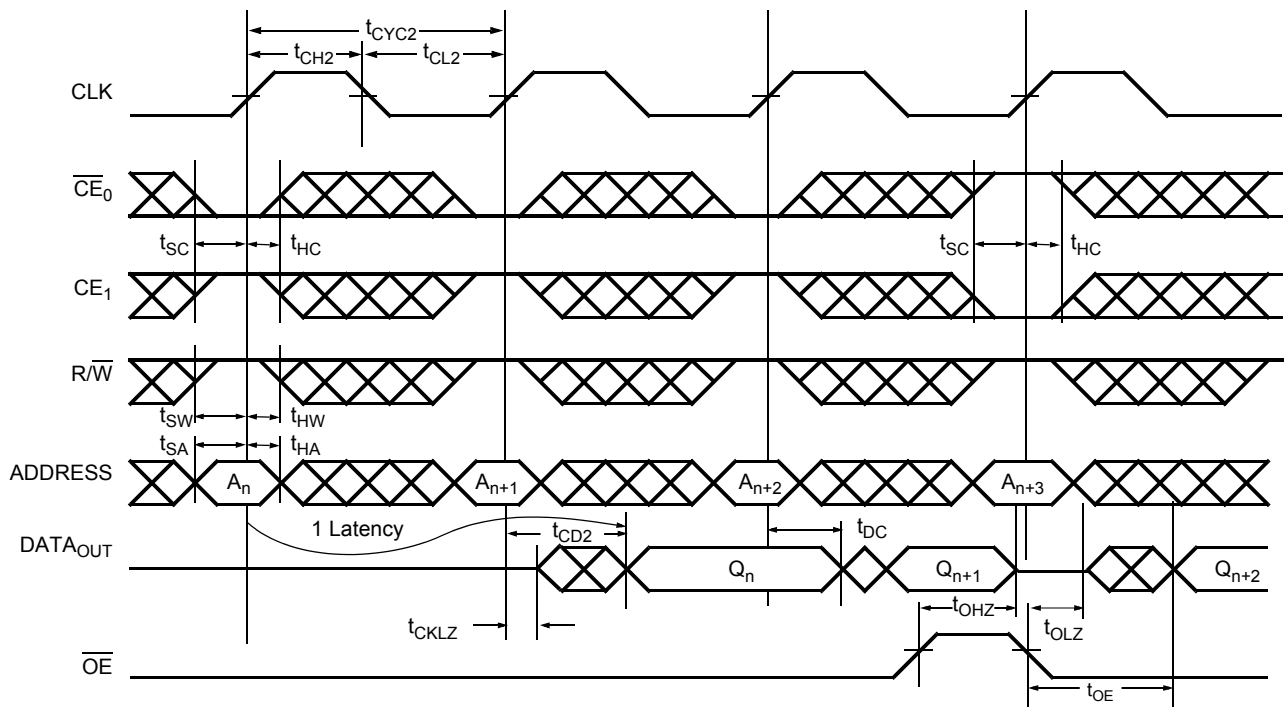
Switching Waveforms (continued)
Read Cycle for Flow-Through Output ($\overline{FT}/PIPE = V_{IL}$)^[16, 17, 18, 19]

Read Cycle for Pipelined Operation ($\overline{FT}/PIPE = V_{IH}$)^[16, 17, 18, 19]

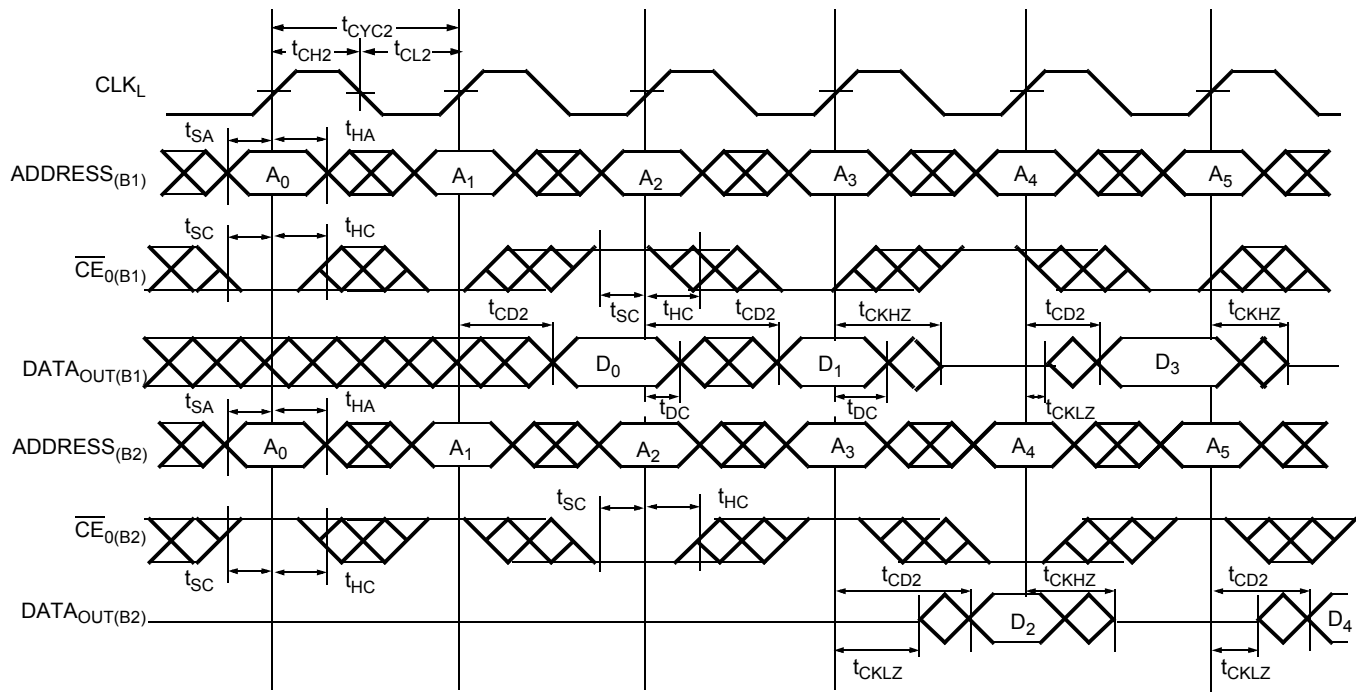
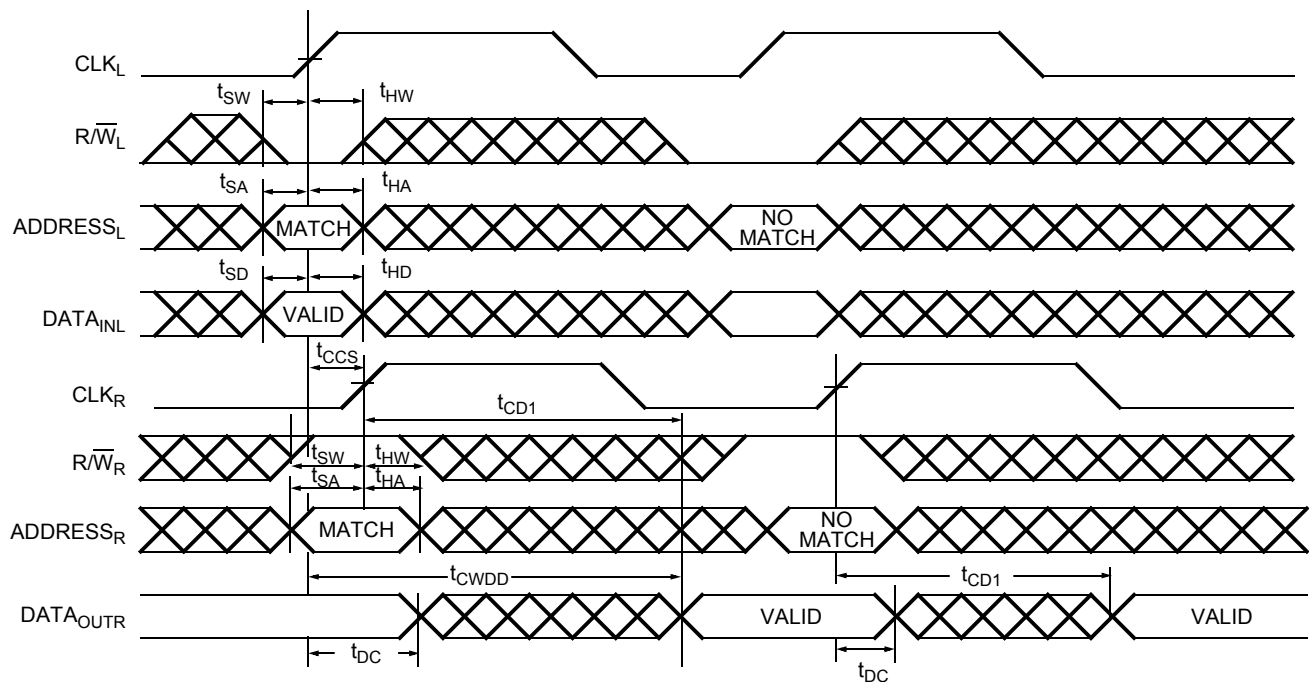
Notes:

16. \overline{OE} is asynchronously controlled; all other inputs are synchronous to the rising clock edge.
17. $ADS = V_{IL}$, $CNTEN$ and $CNTRST = V_{IH}$.
18. The output is disabled (high-impedance state) by $\overline{CE}_0 = V_{IH}$ or $CE_1 = V_{IL}$ following the next rising edge of the clock.
19. Addresses do not have to be accessed sequentially since $ADS = V_{IL}$ constantly loads the address on the rising edge of the CLK. Numbers are for reference only.

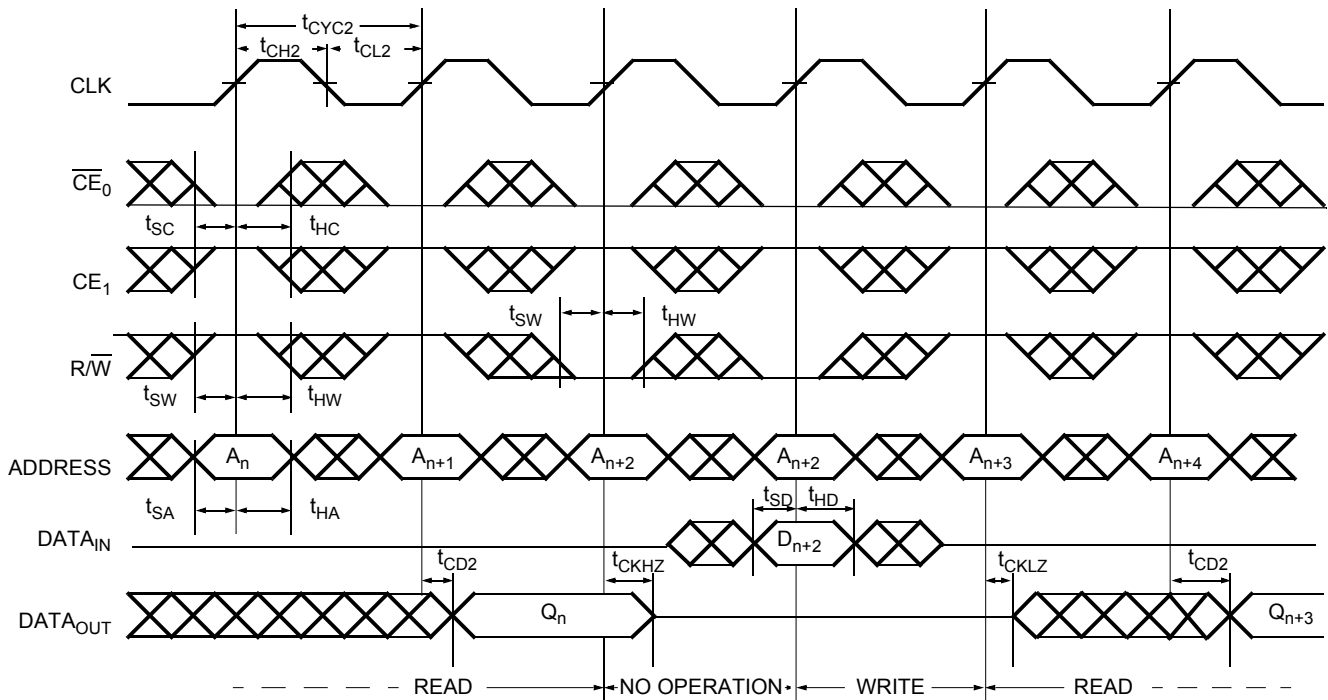
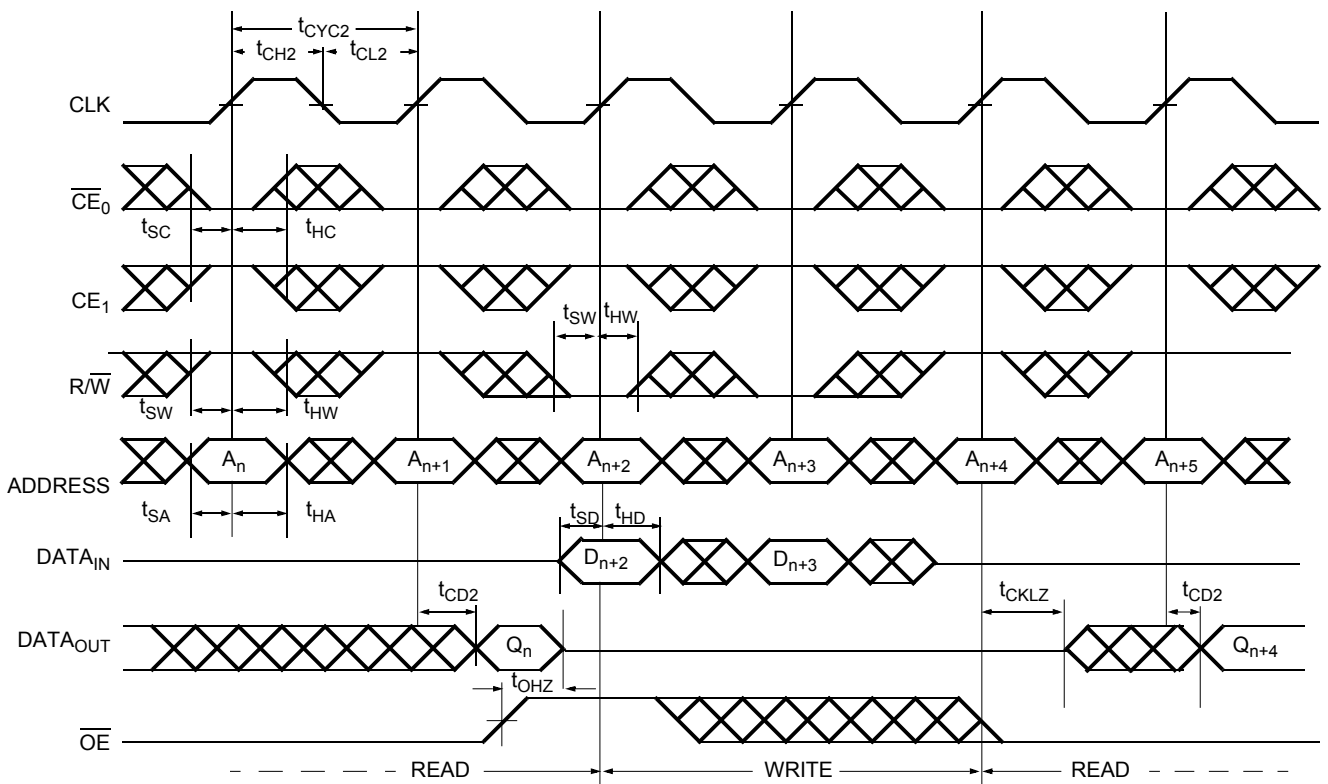
Switching Waveforms (continued)
Bank Select Pipelined Read^[20, 21]

Left Port Write to Flow-Through Right Port Read^[22, 23, 24, 25]

Notes:

20. In this depth expansion example, B1 represents Bank #1 and B2 is Bank #2; Each Bank consists of one Cypress dual-port device from this datasheet. ADDRESS_(B1) = ADDRESS_(B2).
21. OE and ADS = V_{IL}; CE_{1(B1)}, CE_{1(B2)}, R/W, CNTEN, and CNTRST = V_{IH}.
22. The same waveforms apply for a right port write to flow-through left port read.
23. CE₀ and ADS = V_{IL}; CE₁, CNTEN, and CNTRST = V_{IH}.
24. OE = V_{IL} for the right port, which is being read from. OE = V_{IH} for the left port, which is being written to.
25. If t_{CCS} ≤ maximum specified, then data from right port READ is not valid until the maximum specified for t_{CWDD}. If t_{CCS} > maximum specified, then data is not valid until t_{CCS} + t_{CD1}. t_{CWDD} does not apply in this case.

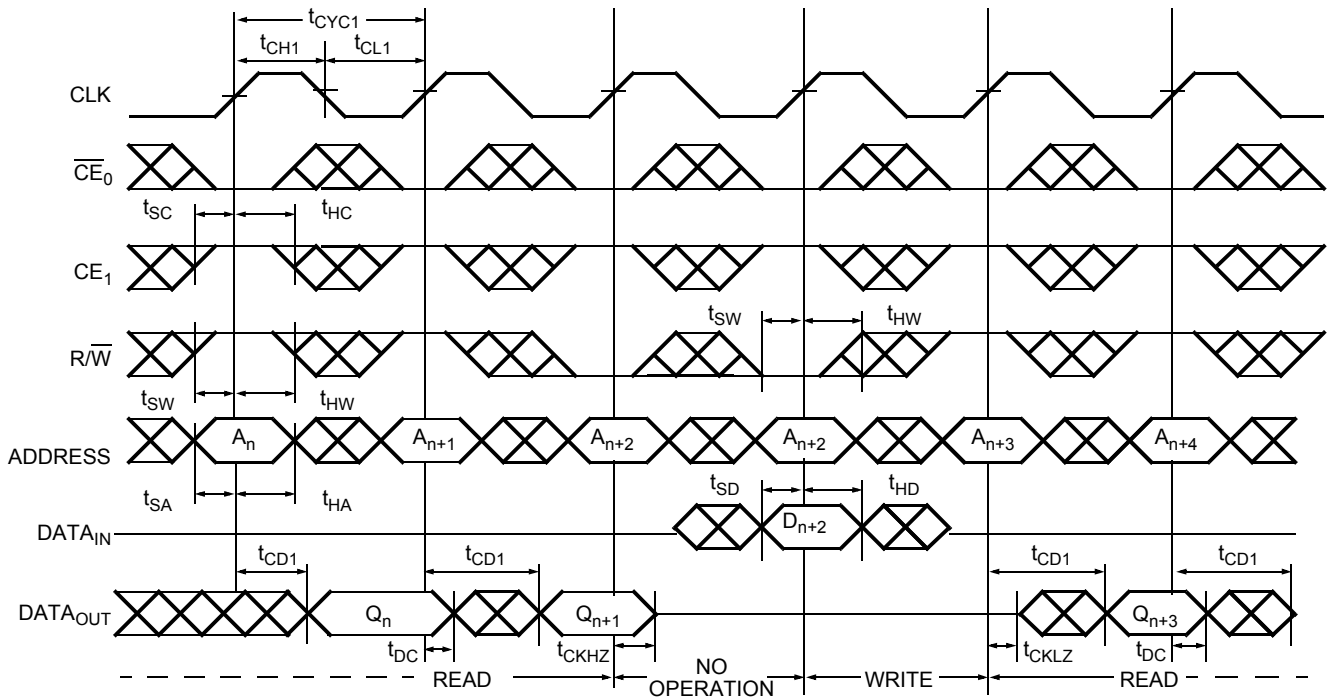
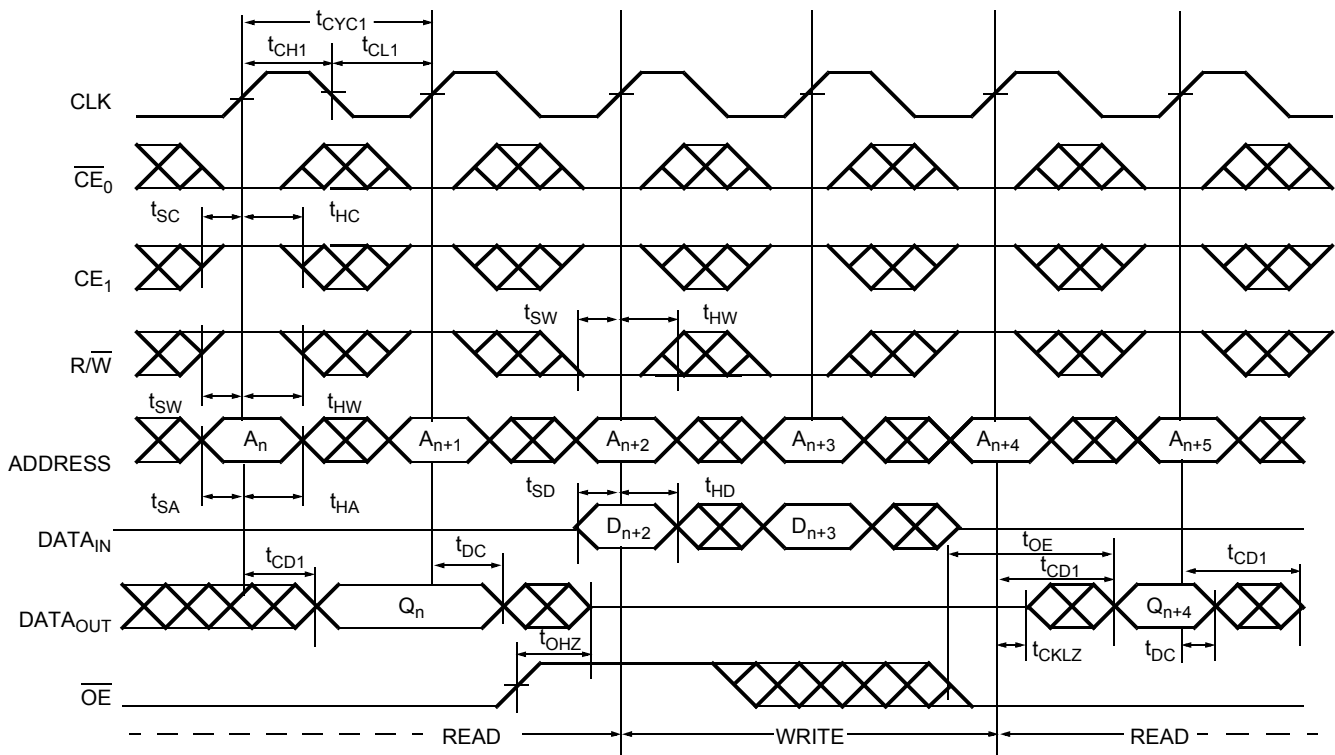
Switching Waveforms (continued)
Pipelined Read-to-Write-to-Read ($\overline{OE} = V_{IL}$)^[19, 26, 27, 28]

Pipelined Read-to-Write-to-Read (\overline{OE} Controlled)^[19, 26, 27, 28]

Notes:

- 26. Output state (HIGH, LOW, or high-impedance) is determined by the previous cycle control signals.
- 27. \overline{CE}_0 and ADS = V_{IL} ; \overline{CE}_1 , CNTEN, and CNTRST = V_{IH} .
- 28. During "No Operation", data in memory at the selected address may be corrupted and should be re-written to ensure data integrity.

Switching Waveforms (continued)
Flow-Through Read-to-Write-to-Read ($\overline{OE} = V_{IL}$)^[17, 19, 26, 27, 28]

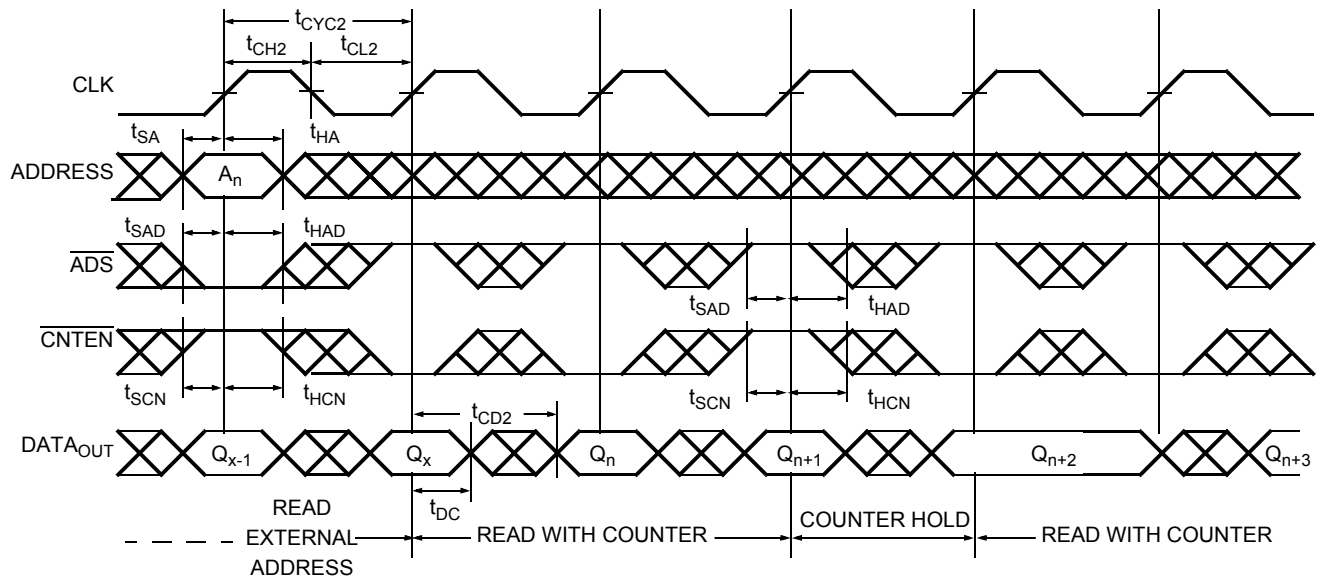
Flow-Through Read-to-Write-to-Read (\overline{OE} Controlled)^[17, 20, 26, 27, 28]

Switching Waveforms (continued)

Pipelined Read with Address Counter Advance^[29]

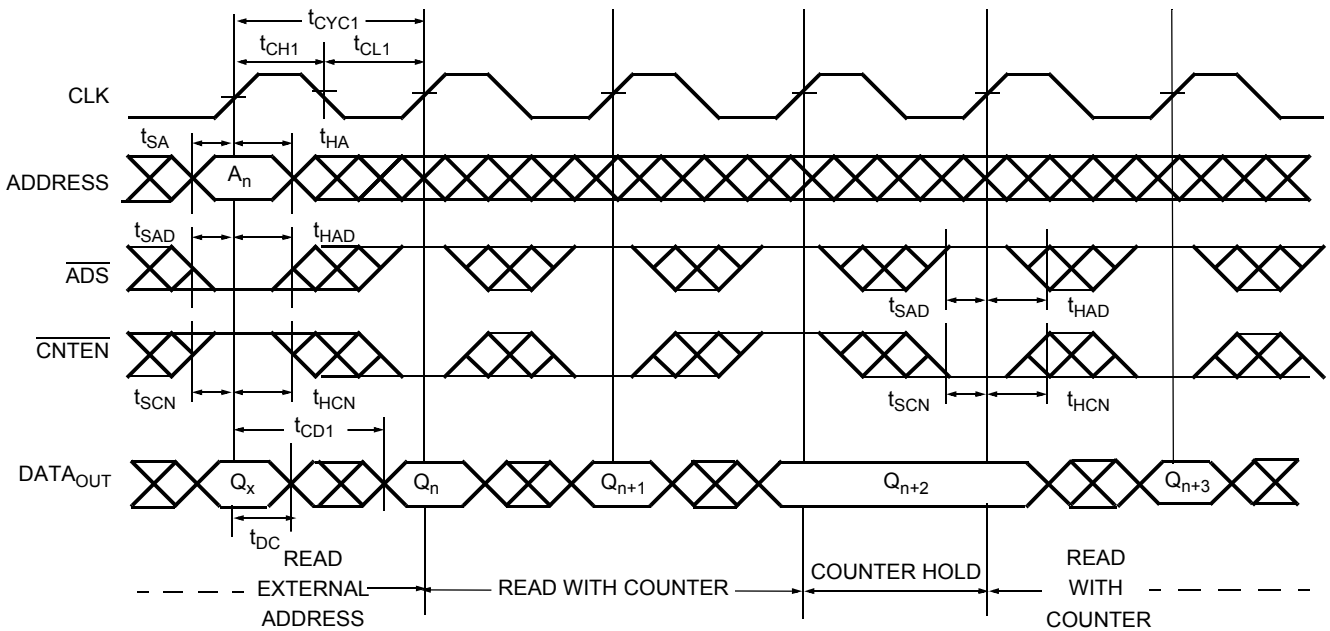

Flow-Through Read with Address Counter Advance^[29]

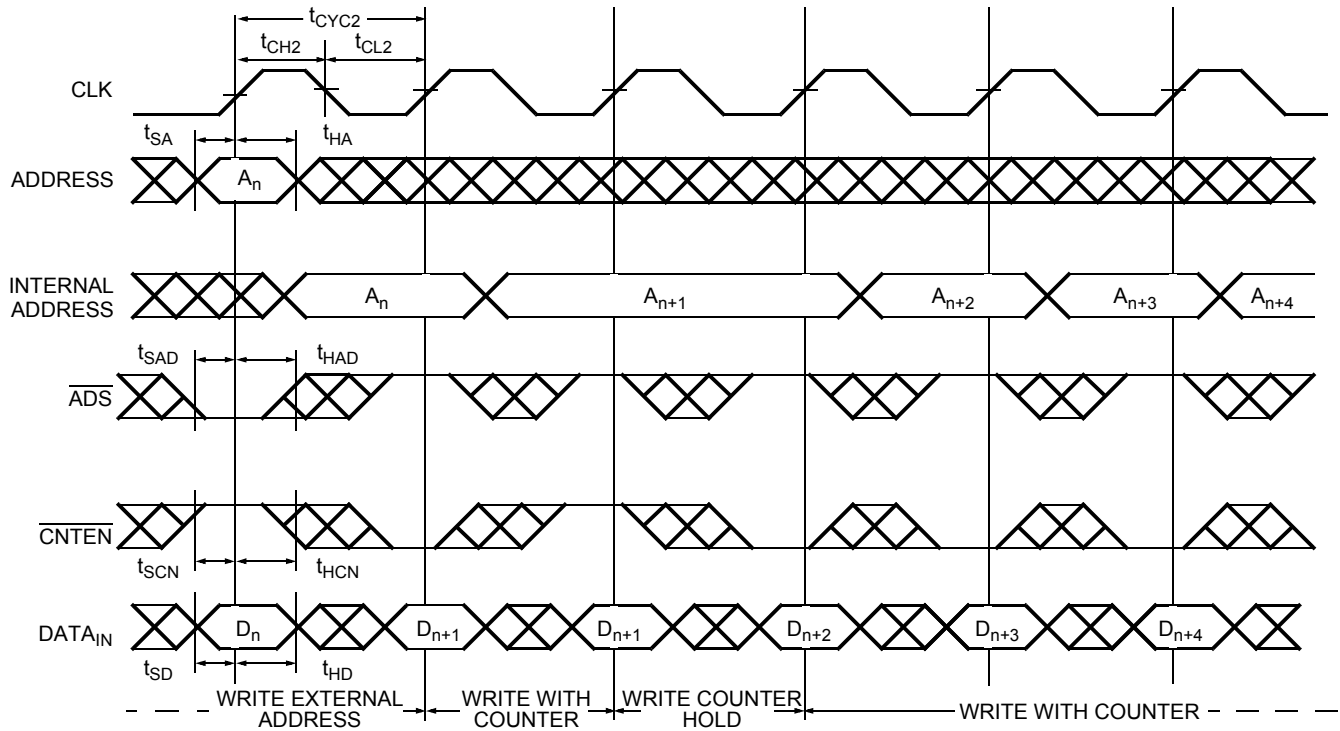

Note:
 29. \overline{CE}_0 and $\overline{OE} = V_{IL}$; CE_1 , R/W and $\overline{CNTEN} = V_{IH}$.

Switching Waveforms (continued)
Write with Address Counter Advance (Flow-Through or Pipelined Outputs)^[30, 31]

Notes:

30. \overline{CE}_0 and $R/\overline{W} = V_{IL}$; \overline{CE}_1 and $\overline{CNTEN} = V_{IH}$.

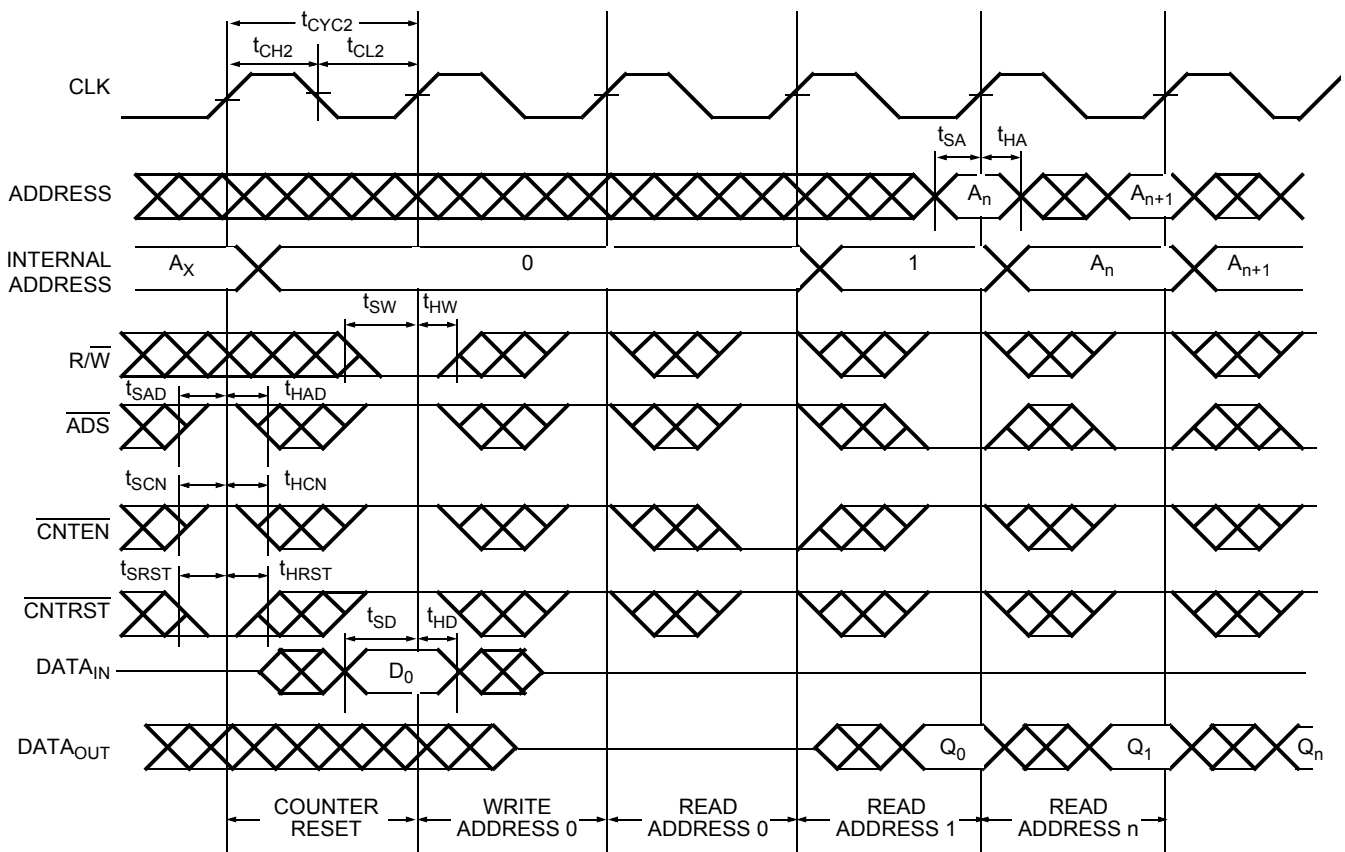



31. The "Internal Address" is equal to the "External Address" when $\overline{ADS} = V_{IL}$ and equals the counter output when $\overline{ADS} = V_{IH}$.

Switching Waveforms (continued)
Counter Reset (Pipelined Outputs)^[19, 26, 32, 33]

Notes:





32. $CE_0 = V_{IL}$; $CE_1 = V_{IH}$.

33. No dead cycle exists during counter reset. A READ or WRITE cycle may be coincidental with the counter reset.

Read/Write and Enable Operation^[34, 35, 36]

| Inputs | | | | | Outputs | Operation |
|--------|---|-----------------|-----------------|-----|------------------------------------|----------------------------|
| OE | CLK | CE ₀ | CE ₁ | R/W | I/O ₀ –I/O ₉ | |
| X |  | H | X | X | High-Z | Deselected ^[37] |
| X |  | X | L | X | High-Z | Deselected ^[37] |
| X |  | L | H | L | D _{IN} | Write |
| L |  | L | H | H | D _{OUT} | Read ^[37] |
| H | X | L | H | X | High-Z | Outputs Disabled |

Address Counter Control Operation^[34, 38, 39, 40]

| Address | Previous Address | CLK | ADS | CNTEN | CNTRST | I/O | Mode | Operation |
|----------------|------------------|---|-----|-------|--------|-----------------------|-----------|---|
| X | X |  | X | X | L | D _{out(0)} | Reset | Counter Reset to Address 0 |
| A _n | X |  | L | X | H | D _{out(n)} | Load | Address Load into Counter |
| X | A _n |  | H | H | H | D _{out(n)} | Hold | External Address Blocked—Counter Disabled |
| X | A _n |  | H | L | H | D _{out(n+1)} | Increment | Counter Enabled—Internal Address Generation |

Notes:

34. "X" = "Don't Care", "H" = V_{IH}, "L" = V_{IL}.

35. ADS, CNTEN, CNTRST = "Don't Care."

36. OE is an asynchronous input signal.

37. When CE changes state in the pipelined mode, deselection and read happen in the following clock cycle.

38. CE₀ and OE = V_{IL}; CE₁ and R/W = V_{IH}.

39. Data shown for flow-through mode; pipelined mode output will be delayed by one cycle.

40. Counter operation is independent of CE₀ and CE₁.

Ordering Information
32K x8 3.3V Synchronous Dual-Port SRAM

| Speed (ns) | Ordering Code | Package Name | Package Type | Operating Range |
|--------------------|-----------------|--------------|-----------------------------|-----------------|
| 6.5 ^[1] | CY7C09079V-6AC | A100 | 100-Pin Thin Quad Flat Pack | Commercial |
| 7.5 ^[1] | CY7C09079V-7AC | A100 | 100-Pin Thin Quad Flat Pack | Commercial |
| | CY7C09079V-7AI | A100 | 100-Pin Thin Quad Flat Pack | Industrial |
| 9 | CY7C09079V-9AC | A100 | 100-Pin Thin Quad Flat Pack | Commercial |
| 12 | CY7C09079V-12AC | A100 | 100-Pin Thin Quad Flat Pack | Commercial |

64K x8 3.3V Synchronous Dual-Port SRAM

| Speed (ns) | Ordering Code | Package Name | Package Type | Operating Range |
|--------------------|------------------|--------------|-------------------------------------|-----------------|
| 6.5 ^[1] | CY7C09089V-6AC | A100 | 100-Pin Thin Quad Flat Pack | Commercial |
| | CY7C09089V-6AXC | A100 | 100-Pin Pb-Free Thin Quad Flat Pack | Commercial |
| 7.5 ^[1] | CY7C09089V-7AC | A100 | 100-Pin Thin Quad Flat Pack | Commercial |
| 9 | CY7C09089V-9AC | A100 | 100-Pin Thin Quad Flat Pack | Commercial |
| 12 | CY7C09089V-12AC | A100 | 100-Pin Thin Quad Flat Pack | Commercial |
| | CY7C09089V-12AXC | A100 | 100-Pin Pb-Free Thin Quad Flat Pack | Commercial |

128K x8 3.3V Synchronous Dual-Port SRAM

| Speed (ns) | Ordering Code | Package Name | Package Type | Operating Range |
|--------------------|------------------|--------------|-------------------------------------|-----------------|
| 6.5 ^[1] | CY7C09099V-6AC | A100 | 100-Pin Thin Quad Flat Pack | Commercial |
| | CY7C09099V-6AXC | A100 | 100-Pin Pb-Free Thin Quad Flat Pack | Commercial |
| 7.5 ^[1] | CY7C09099V-7AC | A100 | 100-Pin Thin Quad Flat Pack | Commercial |
| | CY7C09099V-7AI | A100 | 100-Pin Thin Quad Flat Pack | Industrial |
| | CY7C09099V-7AXI | A100 | 100-Pin Pb-Free Thin Quad Flat Pack | Industrial |
| 9 | CY7C09099V-9AC | A100 | 100-Pin Thin Quad Flat Pack | Commercial |
| | CY7C09099V-9AI | A100 | 100-Pin Thin Quad Flat Pack | Industrial |
| 12 | CY7C09099V-12AC | A100 | 100-Pin Thin Quad Flat Pack | Commercial |
| | CY7C09099V-12AXC | A100 | 100-Pin Pb-Free Thin Quad Flat Pack | Commercial |

32K x9 3.3V Synchronous Dual-Port SRAM

| Speed (ns) | Ordering Code | Package Name | Package Type | Operating Range |
|--------------------|------------------|--------------|-------------------------------------|-----------------|
| 6.5 ^[1] | CY7C09179V-6AC | A100 | 100-Pin Thin Quad Flat Pack | Commercial |
| | CY7C09179V-6AXC | A100 | 100-Pin Pb-Free Thin Quad Flat Pack | Commercial |
| 7.5 ^[1] | CY7C09179V-7AC | A100 | 100-Pin Thin Quad Flat Pack | Commercial |
| 9 | CY7C09179V-9C | A100 | 100-Pin Thin Quad Flat Pack | Commercial |
| 12 | CY7C09179V-12AC | A100 | 100-Pin Thin Quad Flat Pack | Commercial |
| | CY7C09179V-12AXC | A100 | 100-Pin Pb-Free Thin Quad Flat Pack | Commercial |

64K x9 3.3V Synchronous Dual-Port SRAM

| Speed (ns) | Ordering Code | Package Name | Package Type | Operating Range |
|--------------------|------------------|--------------|-------------------------------------|-----------------|
| 6.5 ^[1] | CY7C09189V-6AC | A100 | 100-Pin Thin Quad Flat Pack | Commercial |
| | CY7C09189V-6AXC | A100 | 100-Pin Pb-Free Thin Quad Flat Pack | Commercial |
| 7.5 ^[1] | CY7C09189V-7AC | A100 | 100-Pin Thin Quad Flat Pack | Commercial |
| 9 | CY7C09189V-9AC | A100 | 100-Pin Thin Quad Flat Pack | Commercial |
| 12 | CY7C09189V-12AC | A100 | 100-Pin Thin Quad Flat Pack | Commercial |
| | CY7C09189V-12AXC | A100 | 100-Pin Pb-Free Thin Quad Flat Pack | Commercial |

128K x9 3.3V Synchronous Dual-Port SRAM

| Speed (ns) | Ordering Code | Package Name | Package Type | Operating Range |
|--------------------|------------------|--------------|-------------------------------------|-----------------|
| 6.5 ^[1] | CY7C09199V-6AC | A100 | 100-Pin Thin Quad Flat Pack | Commercial |
| | CY7C09199V-6AXC | A100 | 100-Pin Pb-Free Thin Quad Flat Pack | Commercial |
| 7.5 ^[1] | CY7C09199V-7AC | A100 | 100-Pin Thin Quad Flat Pack | Commercial |
| | CY7C09199V-7AXC | A100 | 100-Pin Pb-Free Thin Quad Flat Pack | Commercial |
| 9 | CY7C09199V-9AC | A100 | 100-Pin Thin Quad Flat Pack | Commercial |
| | CY7C09199V-9AXC | A100 | 100-Pin Pb-Free Thin Quad Flat Pack | Commercial |
| | CY7C09199V-9AI | A100 | 100-Pin Thin Quad Flat Pack | Industrial |
| | CY7C09199V-9AXI | A100 | 100-Pin Pb-Free Thin Quad Flat Pack | Industrial |
| 12 | CY7C09199V-12AC | A100 | 100-Pin Thin Quad Flat Pack | Commercial |
| | CY7C09199V-12AXC | A100 | 100-Pin Pb-Free Thin Quad Flat Pack | Commercial |

Package Diagram

100-Pin Thin Plastic Quad Flat Pack (TQFP) A100
100-Pin Pb-Free Thin Plastic Quad Flat Pack (TQFP) A100

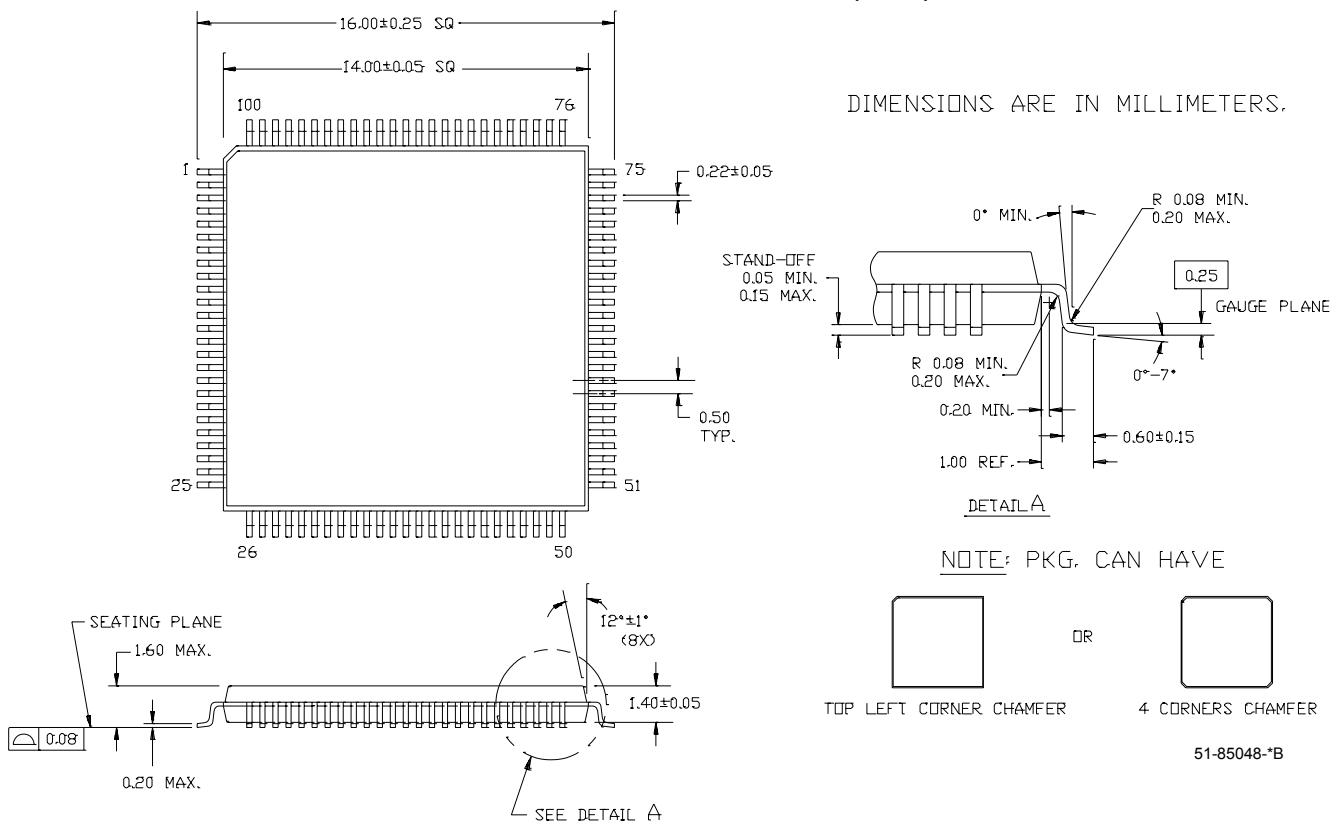

All products and company names mentioned in this document may be the trademarks of their respective holders.

Document History Page

| Document Title: CY7C09079V/89V/99V, CY7C09179V/89V/99V 3.3V 32K/64K/128K x 8/9Synchronous Dual Port Static RAM Document Number: 38-06043 | | | | |
|---|---------|------------|-----------------|---|
| REV. | ECN NO. | Issue Date | Orig. of Change | Description of Change |
| ** | 110191 | 09/29/01 | SZV | Change from Spec number: 38-00667 to 38-06043 |
| *A | 122293 | 12/27/02 | RBI | Power up requirements added to Operating Conditions Information |
| *B | 365034 | See ECN | PCX | Added Pb-Free Logo Added Pb-Free Part Ordering Information: CY7C09089V-6AXC, CY7C09089V-12AXC, CY7C09099V-6AXC, CY7C09099V-7AI, CY7C09099V-7AXI, CY7C09099V-12AXC, CY7C09179V-6AXC, CY7C09179V-12AXC, CY7C09189V-6AXC, CY7C09189V-12AXC, CY7C09199V-6AXC, CY7C09199V-7AXC, CY7C09199V-9AXC, CY7C09199V-9AXI, CY7C09199V-12AXC |