

DBL 5009B

ON-HOOK AMPLIFIER

The DBL 5009 is a monolithic integrated circuit designed for speaker amp.

FEATURES

- Operating supply voltage range : $V_{CC} = 1.5 \sim 5.0$
- Recommended operating supply voltage : $V_{CC} = 3V$
- Low quiescent current : $I_{CCQ} : 2.6mA$
- Package is compact.

APPLICATION

- Telephone set

MAXIMUM RATINGS

8DIP

Unit: mm

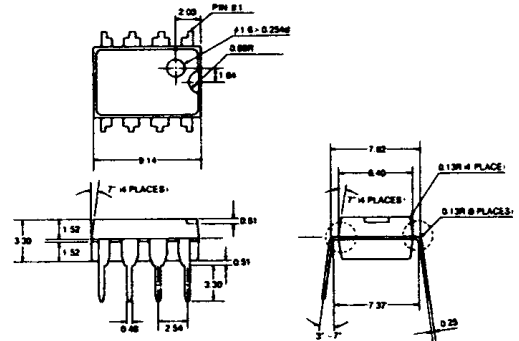

Characteristics	Symbol	Rating	Unit
Supply Voltage	V_{CC}	10	V
Power Dissipation	P_D	800	mW
Operating Temperature	T_{opr}	-12 ~ +60	°C
Storage Temperature	T_{stg}	-55 ~ +150	°C

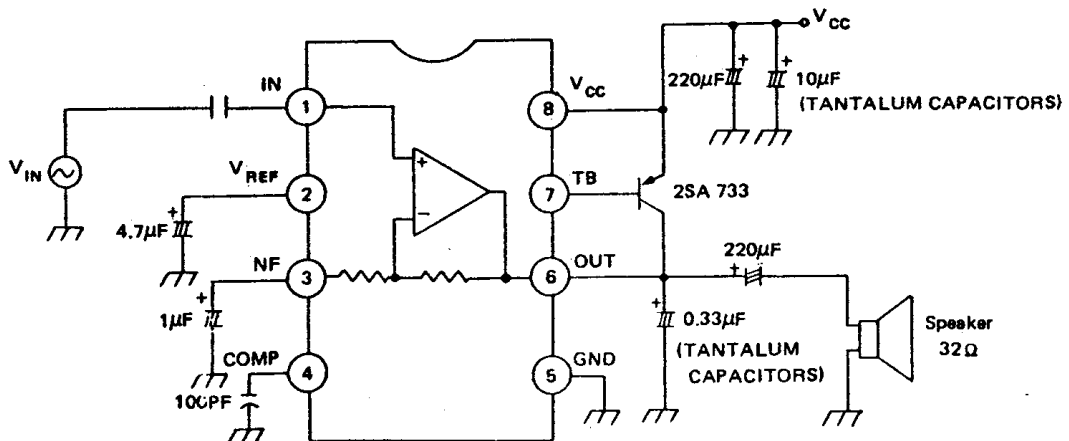

DBL 5009B

ELECTRICAL DC CHARACTERISTICS

(Pin voltage at $V_{CC}=3V$ and no input signal)

Pin No.	Symbol	Typical Value	Unit	Pin No.	Symbol	Typical Value	Unit
1	V_1	1.4	V	5	V_5	0	V
2	V_2	1.4	V	6	V_6	1.5	V
3	V_3	1.4	V	7	V_7	2.3	V
4	V_4	1.3	V	8	V_8	3.0	V

ELECTRICAL AC CHARACTERISTICS

(Unless otherwise specified, $V_{CC}=3V$, $f=1KHz$, $V_{IN}=20mV_{rms}$, $R_L=32\Omega$, $T_a=25^\circ C$)

Characteristic	Symbol	Test condition	Min.	Typ.	Max.	Unit
Quiescent Current	I_{CCO1}	$V_{CC}=2.0V$		2.0		mA
	I_{CCO2}	$V_{CC}=3.0V$		2.6		mA
	I_{CCO3}	$V_{CC}=5.0V$		3.5		mA
Close Loop Voltage Gain	G_V			27		dB
Maximum Output Voltage	V_{OM}	THD = 10 %		1.0		V_{rms}
Total Harmonic Distortion	THD	$V_{IN}=40mV_{rms}$		0.6		%
Output noise Voltage	V_{NO}	$V_{IN}=0$		200		μV_{rms}
Input Resistance	R_{IN}			15		$K\Omega$

TYPICAL PERFORMANCE CHARACTERISTICS

