

VCR standard audio signal processor BA7795LS / BA7795FS

The BA7795LS and BA7795FS are standard audio signal processor ICs. They contain a playback preamplifier, line amplifier, recording amplifier, ALC circuit, EQ switch circuit and high-voltage head switch, and provide all of the functions required for normal-audio signal processing on a single IC with a minimum number of external components required.

●Applications

Video cassette recorders and tape decks

●Features

- 1) Available in compact SZIP and SSOP-A24-pin packages.
- 2) High-with standing-voltage head switch (AC with standing voltage: Min. 80V_{P-P} (f = 70kHz)).
- 3) Simple, three-mode EQ switch built-in (BA7795LS).
- 4) Built-in LINE / TUNER selector switch.
- 5) High-performance low-noise playback amplifier.
- 6) ALC level can be varied.
- 7) ALC loop external mute eliminates audible noise at power on, and ALC attack noise.
- 8) Signal processing circuit can be constructed with the addition of just a few external components.

●Block diagram

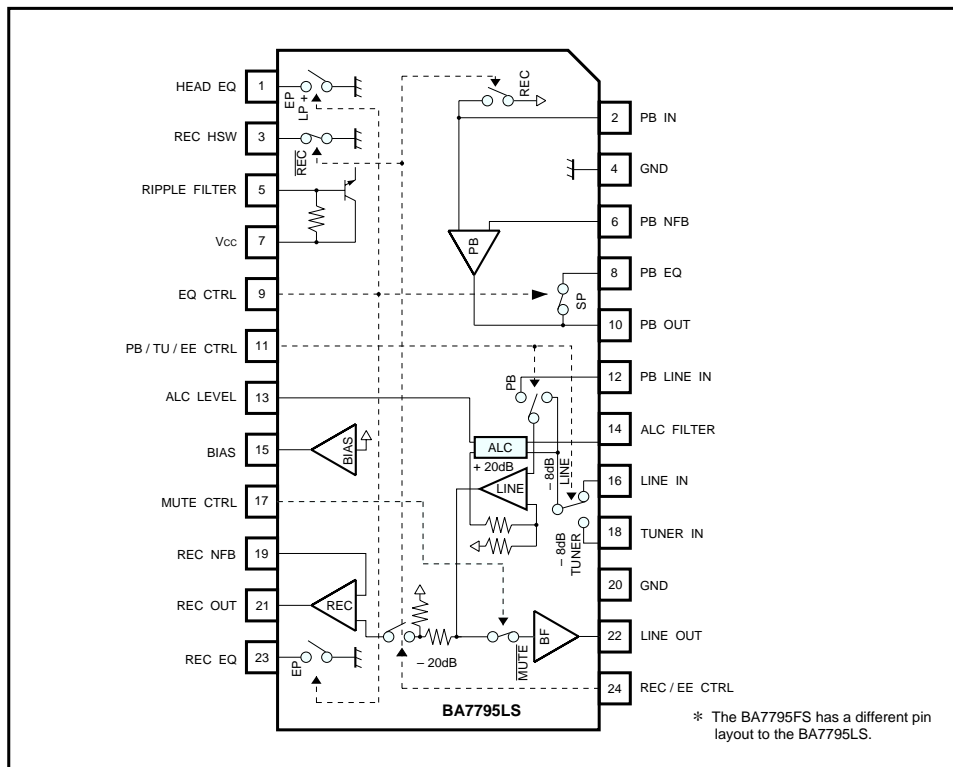

●Absolute maximum ratings (Ta = 25°C)

Parameter	Symbol	Limits	Unit
Applied voltage	V _{cc}	13	V
Power dissipation	BA7795LS	400*1	mW
	BA7795FS	800*2	
Operating temperature	T _{opr}	- 10 ~ + 65	°C
Storage temperature	T _{stg}	- 55 ~ + 125	°C

*1 Reduced by 4.0mW for each increase in Ta of 1°C over 25°C.

*2 Reduced by 8.0mW for each increase in Ta of 1°C over 25°C.

●Recommended operating conditions (Ta = 25°C)

Parameter	Symbol	Limits	Unit
Power supply voltage	V _{cc}	7.5 ~ 12.5	V

●Pin descriptions

BA7795LS Pin No.	BA7795FS Pin No.	Pin name	Function
1	7	HEAD EQ	Head resonance capacitor switch
2	8	PB IN	Playback amplifier input / playback head switch
3	9	REC HSW	High-withstanding voltage recording head switch
4	10	GND	GND (playback amplifier)
5	11	RIPPLE FILTER	Ripple filter
6	12	PB NFB	Playback amplifier feedback
7	13	V _{cc}	Power supply
8	14	PB EQ	Playback EQ switch
9	15	EQ CTRL	EQ control
10	16	PB OUT	Playback amplifier output
11	17	PB / TU / EE CTRL	PB / TU / EE control (PB / EE control)
12	18	PB LINE IN	Playback line amplifier
13	19	ALC LEVEL	ALC level setting
14	20	ALC FILTER	ALC filter time constant
15	21	BIAS	Bias
16	22	LINE IN	Line input
17	23	MUTE CTRL	MUTE control
18	24	TUNER IN	Tuner input (REC / EE control)
19	1	REC NFB	Recording amplifier feedback
20	2	GND	GND
21	3	REC OUT	Recording amplifier output
22	4	BF OUT	Line amplifier output
23	5	REC EQ	Recording EQ switch (recording EQ switch 2)
24	6	REC / EE CTRL	REC / EE control (recording EQ switch 1)

●Electrical characteristics (unless otherwise noted, $T_a = 25^\circ\text{C}$, $V_{CC} = 9\text{V}$, and $f = 1\text{kHz}$)

Parameter	Symbol	Min.	Typ.	Max.	Unit	Conditions
Quiescent current EE	I_{qEE}	6.3	8.3	10.8	mA	When no signal
Quiescent current PB	I_{qPB}	6.3	8.3	10.8	mA	When no signal
Quiescent current REC	I_{qREC}	4.9	6.4	8.4	mA	When no signal
〈Line amplifier〉						
Power supply gain (PB input)	G_{VCP}	27.0	28.0	29.0	dB	$V_o = -8\text{dBV}$
Power supply gain (LINE1, LINE2, TU inputs)	G_{VCL}	19.0	20.0	21.0	dB	$V_o = -8\text{dBV}$
Distortion	THDL	—	0.1	0.3	%	$V_o = -8\text{dBV}$, $R_L = 4.7\text{k}\Omega^{*1}$
Maximum output level	V_{OmL}	5.0	7.2	—	dBV	THD = 1%, $R_L = 4.7\text{k}\Omega^{*1}$
Output residual noise	V_{NOL}	—	-81.5	-75	dBV	$R_g = 4.7\text{k}\Omega$, DIN AUDIO
ALC level	V_{OA}	-7.0	-6.0	-5.0	dBV	$V_{IN} = -23\text{dBV}$ $R_1 / R_2 = 8.2 / 39\text{k}\Omega$
ALC distortion	THDA	—	0.18	0.5	%	$V_{IN} = -23\text{dBV}$, $R_L = 4.7\text{k}\Omega^{*1}$
Mute attenuation ratio	MT	—	-82.5	-72	dB	$V_o = 0\text{dBV}$, DIN AUDIO
〈Recording amplifier〉						
Voltage gain	G_{VCR}	19.0	20.0	21.0	dB	LINE, TUNER input→REC OUT
Distortion	THDR	—	0.03	0.3	%	$V_o = -8\text{dBV}$
Maximum output level	V_{OmR}	5.5	7.4	—	dBV	$V_o = -8\text{dBV}$, $R_L = 4.7\text{k}\Omega^{*1}$
Open loop gain	G_{VOR}	65	77	—	dB	THD = 1%, $R_L = 4.7\text{k}\Omega^{*1}$
〈Playback preamplifier〉						
Open loop gain	G_{VOP}	62	68	—	dB	
Input conversion noise	V_{NINP}	—	-122.5	-114	dBV	$R_g = 680\Omega$, DIN AUDIO
Total gain	G_{VCP-L}	56	57.5	59	dB	PB IN →BF OUT
〈Head switch〉						
PB head switch impedance	R_{PH}	—	11	20	Ω	
REC head switch impedance	R_{RH}	—	11	20	Ω	
REC head switch AC withstanding voltage	BV_{RHAC}	80	100	—	V _{P-P}	$f = 70\text{kHz}$

*1 Measured at BW = 400Hz to 30kHz.

● Input / output circuits

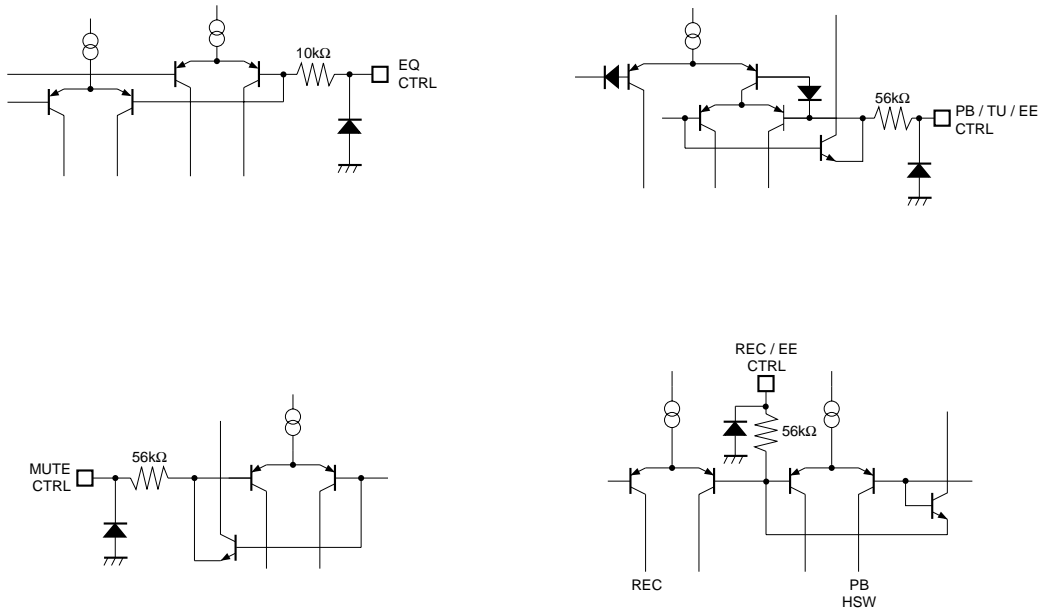
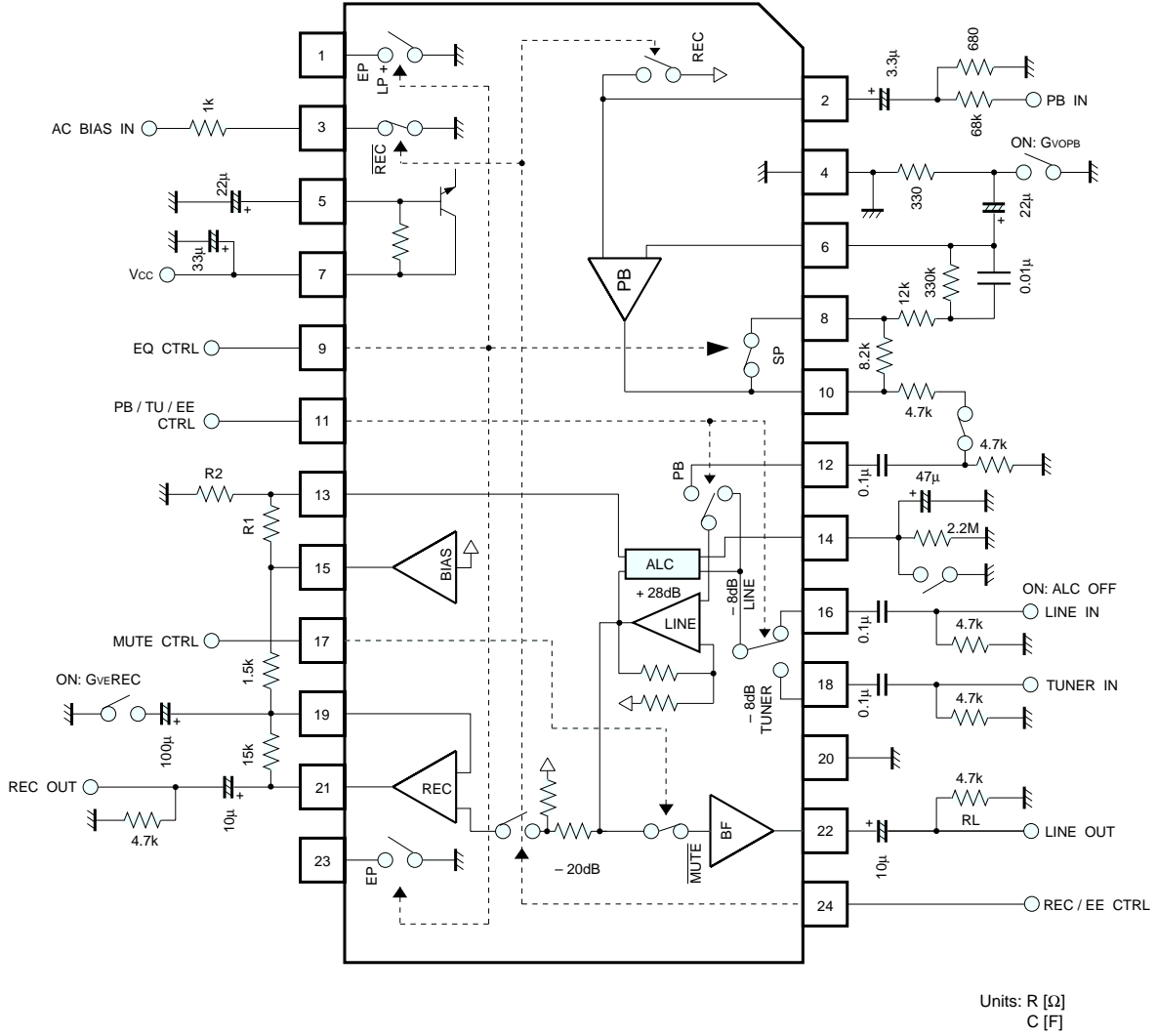

Fig. 1

● Measurement circuit

BA7795LS



* The BA7795FS has a different pin layout to the BA7795LS.

Fig. 2

●Circuit operation

(1) EE operation

The input switch is used to select the audio signal input source (LINE or TUER). This signal is amplified by the line amplifier (voltage gain: 20dB at 1kHz).

The ALC circuit controls the line amplifier output level.

The ALC level is set externally.

If mute mode is set in this state, the switch that connects the output buffer will go off, but the ALC loop will not be cut.

(2) Recoeding

In recording mode, the recording amplifier directly connected to the line amplifier operates.

The PB HEAD switch in the playback equalizer amplifier block switches on, and the signal is not input to the playback equalizer amplifier.

The line amplifier output is attenuated by 20dB before it is input to the recording amplifier, so if the feedback components are chosen to give a gain of 20dB, the same REC OUT output level as the line amplifier can be obtained.

It is also possible to switch the REC equalizer characteristic to suit the tape speed by switching the control signal to EQ CTRL. The recording amplifier gain and equalizer characteristics are set externally.

Signal flow for EE and recording operation

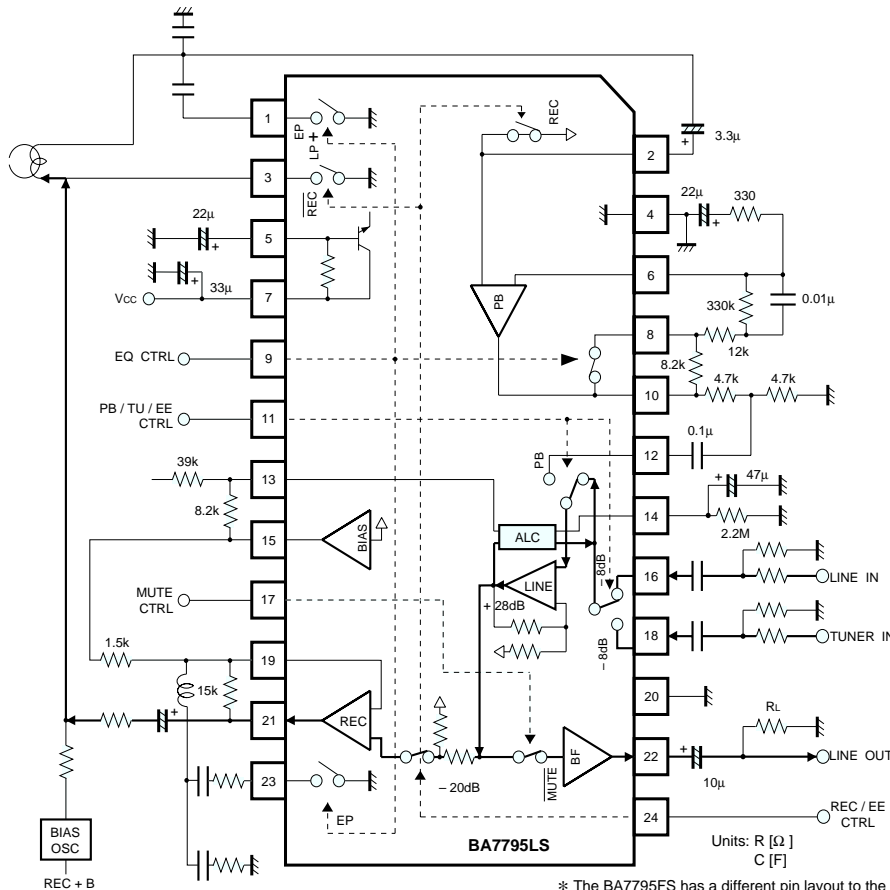

* The BA7795FS has a different pin layout to the BA7795LS.

Fig. 3 Signal flow for EE / recording

(3) Playback operation

The signal applied to PB IN is amplified by playback equalizer amplifier. At this time, the REC HEAD switch is switched on by a control signal to REC / EE, and the potential on one side of the head is fixed at GND. The playback equalizer amplifier gain and equalizer characteristics are set externally. The playback level is set by the resistor divider between PB OUT and the playback line input, The signal to the playback line input passes through the input switch, is amplified by 20dB in the line amplifier, and is output to the output buffer (the voltage

gain is different to that for the LINE input and TUNER input).

It is possible to switch between the input block head equalizer resonance point and playback equalizer characteristic using the EQ CTRL control signal.

The line output can be stopped by setting muting mode on using the MUTE CTRL signal. The ALC circuit and recording amplifier are stopped in playback mode.

Signal flow for playback operation

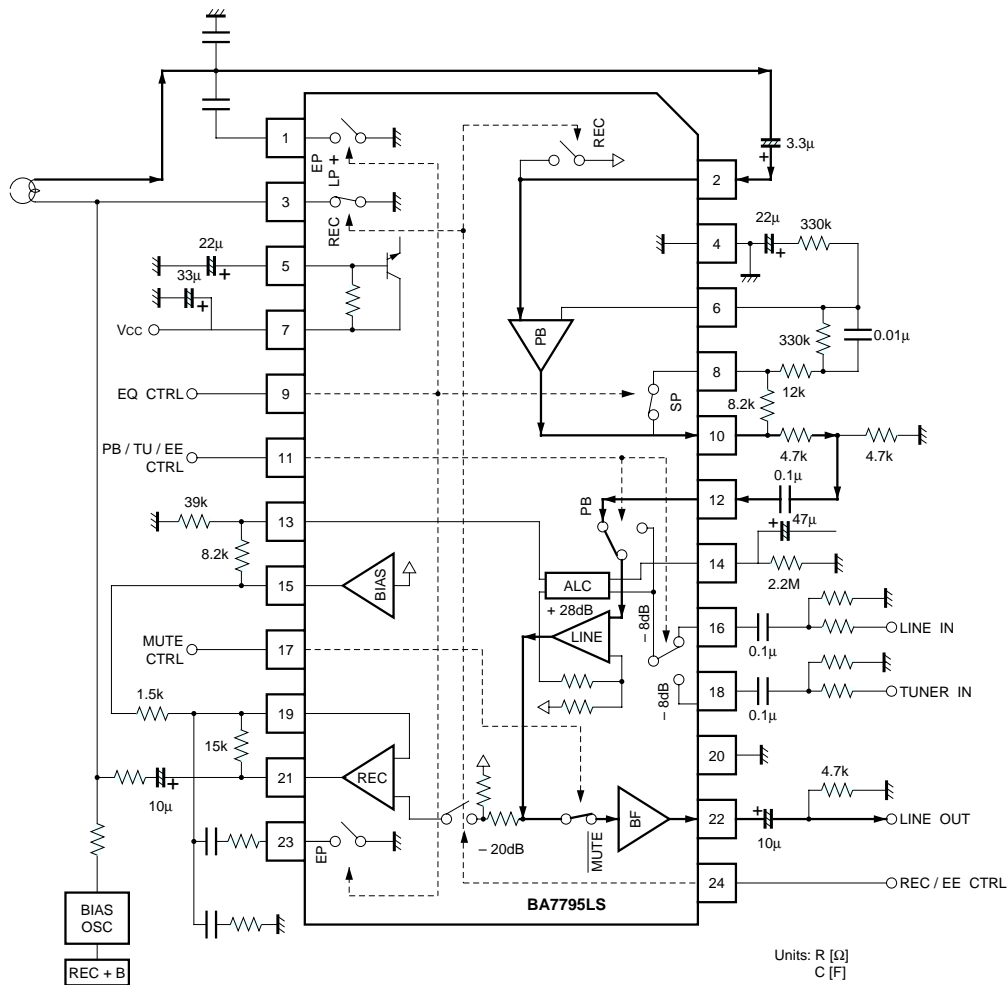

Fig. 4 Signal flow for playback

●Control mode table

(1) REC / EE CTRL, PB / TU / EE CTRL

Control pins		Mode	Function			
REC / EE	PB / TU / EE		PB HSW	REC HSW	LINE SW	REC AMP
L	L	LINE	OFF	ON	LINE	OFF
L	M	TUNER	OFF	ON	TUNER	OFF
L	H	PB	OFF	ON	PB	OFF
H	L	LINE REC	ON	OFF	LINE	ON
H	M	TUNER REC	ON	OFF	TUNER	ON
H	H	inhibit	—	—	—	—

If REC / EE CTRL is set to "M", the REC pause state is possible (REC head switch: open, REC amplifier: off).

(2) MUTE CTRL

Control pins	Mode	Function
MUTE		LINE SW
H	MUTE	OPEN
L	$\overline{\text{MUTE}}$	CLOSE

(3) EQ CTRL

Control pins	Mode		Function		
	2 MODE	3 MODE	HEAD EQ SW	PB EQ SW	REC EQ SW
L	SP	SP	OFF	CLOSE	OFF
M	—	LP	ON	OPEN	OFF
H	EP	EP	ON	OPEN	ON

The L, M and H thresholds are: L to M: 1.7V, L to H: 2.5V, and M to H: 3.3V.

●Application example (BA7795LS)

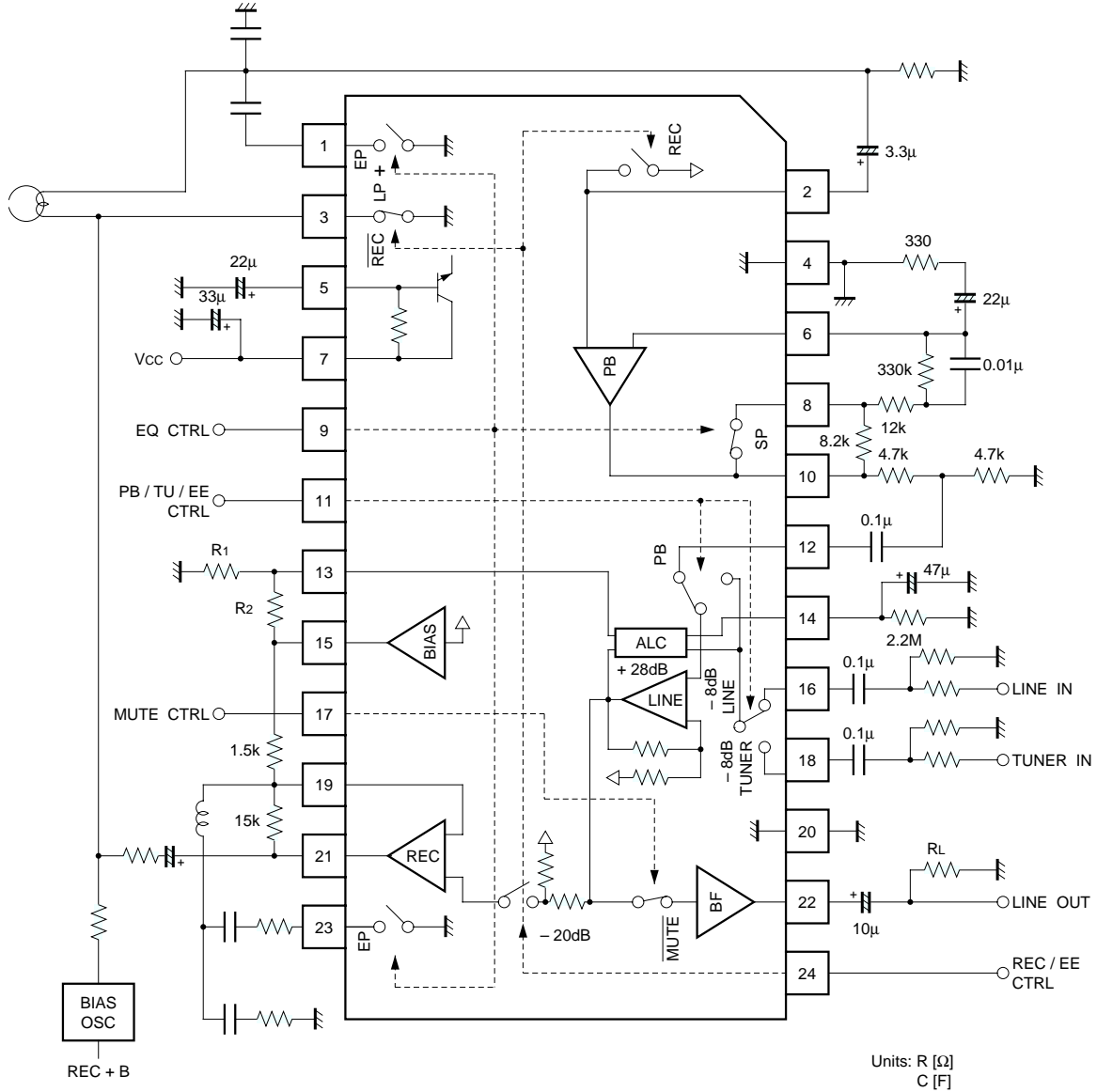

* The BA7795FS has a different pin layout to the BA7795LS.

Fig. 5

●Operation notes

(1) ALC level

Set the ALC level in the range - 8dBV to 0dBV by selecting the values of resistors R1 and R2 connected between BIAS, ALC LEVEL and GND.

The formula for approximating the value of this resistor is as follows:

$$V_{OA} = \frac{1}{\sqrt{2}} \cdot \frac{V_{CC} - 0.7}{2} \cdot \frac{R_1}{R_1 + R_2}$$

$$= \frac{1}{\sqrt{2}} \cdot \frac{R_1}{R_1 + R_2} \cdot V_{BIAS}$$

If the ALC level setting is too low, level variation will increase compared to that of the standard level ($V_{OA} = - 6dBV$), and conversely, if the level is too high, the level variation will decrease, but distortion will increase. There is almost no temperature characteristic, but the ALC level does vary with supply voltage (V_{CC}) as shown in the formula above. Use care when setting it.

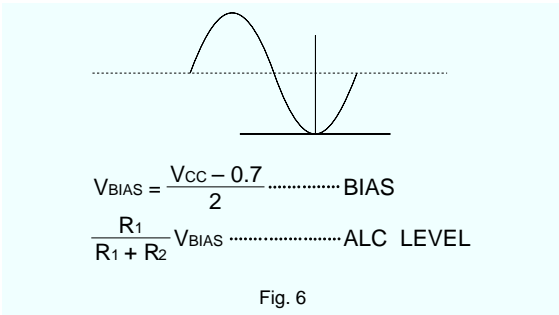

(2) Mute signal

Apply the mute signal shown below at power on and off. If the muting time is short, a pop sound will be audible, particularly when the power is switched on.

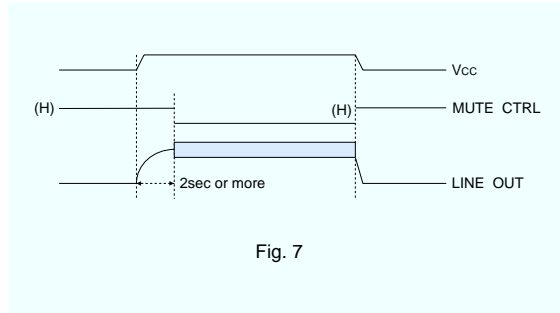

Also, be certain to apply the mute signal when switching between PB / LINE / TU. In the case of LINE / TU switching, it is possible to suppress switching noise by applying a time constant to the signal, in which case it is not necessary to apply the mute signal.

(3) Recording control

Do not switch the PB and REC modes on together. This will cause faulty operation.

(4) Line output

The line output can drive a load resistance of up to 2kΩ. Depending on the type of load, it can cause local oscillation (eg. large capacitive loads that draw large current), so caution is required. In particular, when there is a possibility that the line output will be connected to a shielded cable, or line cable, connect a resistor of about 1kΩ in series with the output so that the capacitive load is not directly coupled to the IC output terminal.

●Electrical characteristic curves

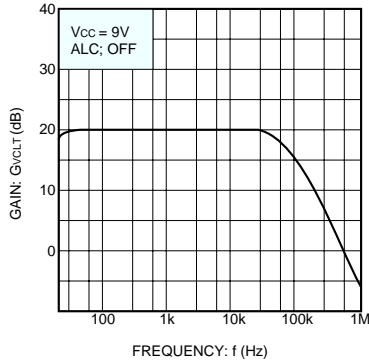

Fig. 8 Gain vs. frequency (PB amplifier)

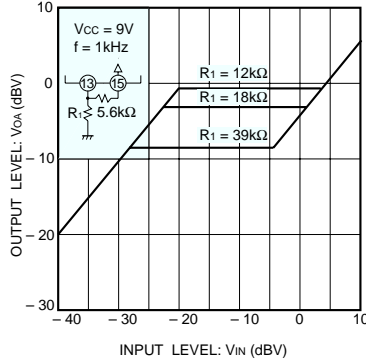

Fig. 9 Line amplifier ALC input / output characteristics

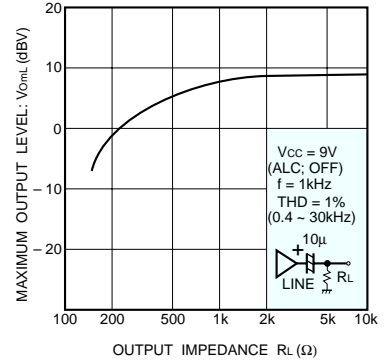

Fig. 10 Line amplifier load drive characteristics

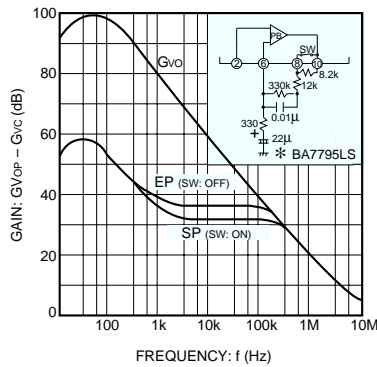

Fig. 11 Playback amplifier frequency characteristics

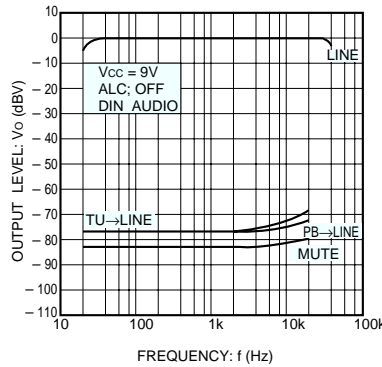

Fig. 12 Line amplifier crosstalk characteristics

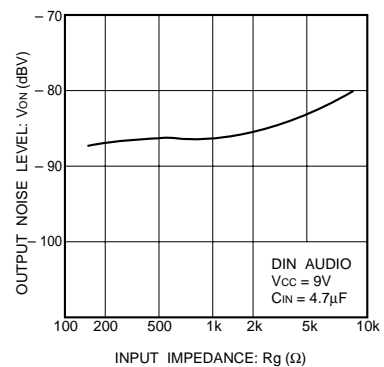

Fig. 13 Playback amplifier output noise characteristics

●External dimensions (Units: mm)

