

# 3-phase motor driver

## BA6871BS

The BA6871BS is a 3-phase, full-wave, pseudo-linear motor driver suited for VCR capstan motors. The IC has a torque ripple cancellation circuit to reduce wow and flutter, and an output transistor saturation prevention circuit that provides superb motor control over a wide range of current. The built-in motor power series regulator allows applications with low power consumption.

### ● Applications

3-phase VCR capstan motors

### ● Features

- 1) 3-phase, full-wave, pseudo-linear driver system.
- 2) High performance torque ripple cancellation circuit.
- 3) Reversal braking by detecting the motor direction.
- 4) Saturation prevention circuit for high- and low-side output transistors.
- 5) Motor power supply series regulators.
- 6) Built-in circuit for output-to-GND short-circuit detection.
- 7) Two FG amplifiers.
- 8) Available in a SDIP 32-pin power shrink package.

### ● Absolute maximum ratings (Ta=25°C)

| Parameter                | Symbol              | Limits               | Unit |
|--------------------------|---------------------|----------------------|------|
| Power supply             | V <sub>CC1</sub>    | 7                    | V    |
| Power supply             | V <sub>M</sub>      | 36                   | V    |
| Power supply             | V <sub>CC2</sub>    | 36                   | V    |
| Power supply             | AMP—V <sub>CC</sub> | 14                   | V    |
| Power dissipation        | P <sub>d</sub>      | 1700*1               | mW   |
| Operating temperature    | T <sub>opr</sub>    | −20~75               | °C   |
| Storage temperature      | T <sub>stg</sub>    | −40~150              | °C   |
| Allowable output current | I <sub>opeak</sub>  | 1.5*2                | A    |
| Input voltage            | V <sub>IN</sub>     | −0.2~V <sub>CC</sub> | V    |

\*1 Reduce power by 13.6 mW for each degree above 25 °C.

\*2 Should not exceed P<sub>d</sub>- or ASO-value.

### ● Recommended operating conditions (Ta=25°C)

| Parameter                      | Symbol              | Min. | Typ. | Max. | Unit |
|--------------------------------|---------------------|------|------|------|------|
| Operating power supply voltage | V <sub>CC1</sub>    | 4    | 5    | 6    | V    |
| Operating power supply voltage | V <sub>CC2</sub>    | 3    | —    | 32   | V    |
| Operating power supply voltage | V <sub>M</sub>      | 3    | 12   | 32   | V    |
| Operating power supply voltage | AMP—V <sub>CC</sub> | 4    | 12   | 13   | V    |

⊙ Not designed for radiation resistance

● Block diagram

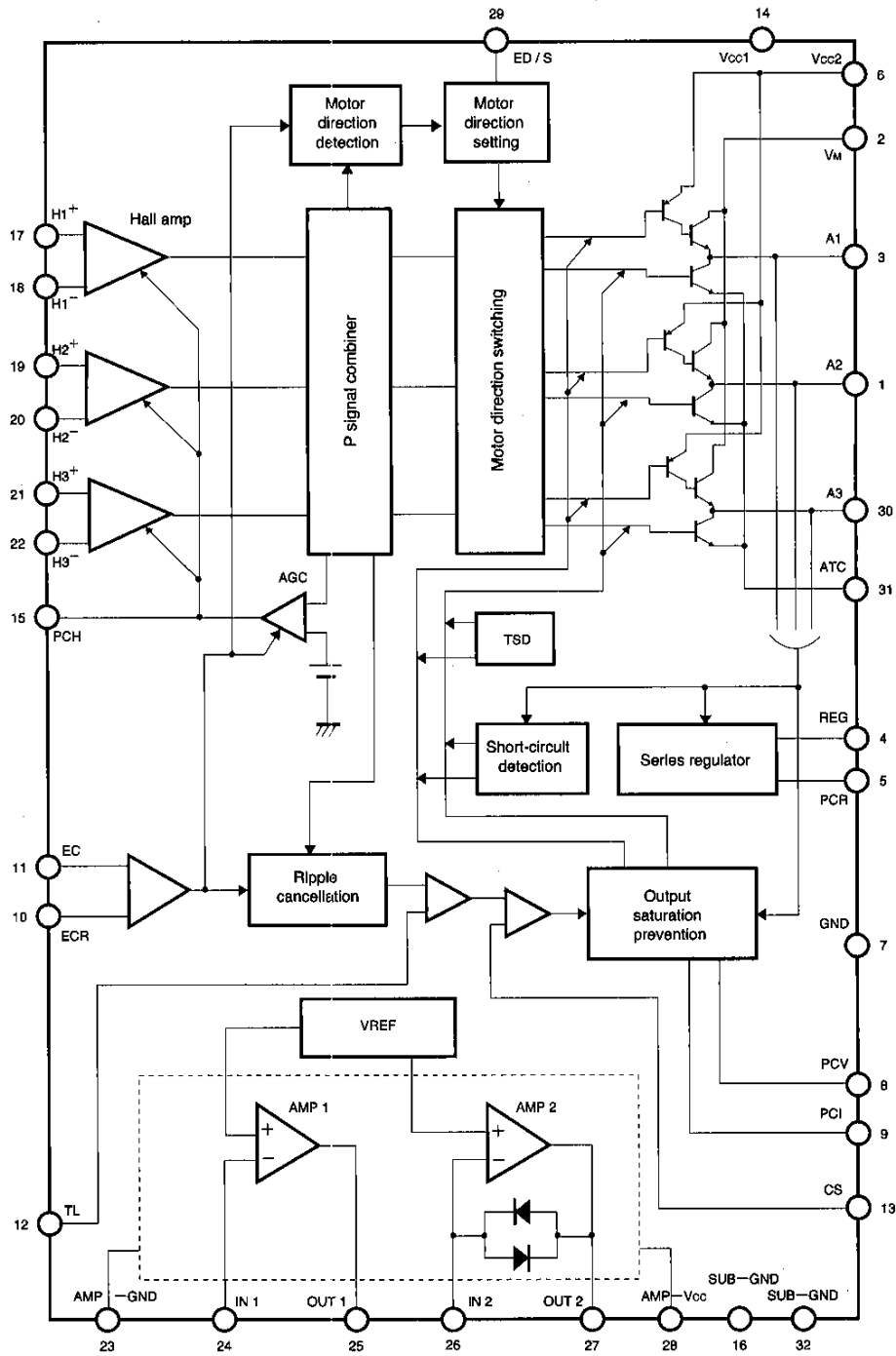

## ● Pin descriptions

| Pin No. | Pin name            | Function  | No. of I/O circuits |
|---------|---------------------|---|---------------------|
| 1       | A2                  | Motor output  | 1                   |
| 2       | V <sub>M</sub>      | Motor power supply  | 1                   |
| 3       | A1                  | Motor output  | 1                   |
| 4       | REG                 | Series regulator sink output                                  | 6                   |
| 5       | PCR                 | Series regulator phase compensation                           | 6                   |
| 6       | V <sub>cc2</sub>    | Signal power supply 2   | 1                   |
| 7       | GND                 | Signal ground pin   |                     |
| 8       | PCV                 | Phase compensation for preventing driver high-side saturation |                     |
| 9       | PCI                 | Phase compensation for preventing driver low-side saturation  |                     |
| 10      | ECR                 | Torque control reference input                                | 4                   |
| 11      | EC                  | Torque control signal input                                   | 4                   |
| 12      | TL                  | Torque limit  | 5                   |
| 13      | CS                  | Current sensing input   | 5                   |
| 14      | V <sub>cc1</sub>    | Signal power supply 1   |                     |
| 15      | PCH                 | Hall amplifier AGC phase compensation                         |                     |
| 16      | SUB—GND             | SUB ground pin, also serves as a radiation fin                |                     |
| 17      | H1 <sup>+</sup>     | Hall signal input   | 2                   |
| 18      | H1 <sup>-</sup>     | Hall signal input   | 2                   |
| 19      | H2 <sup>+</sup>     | Hall signal input   | 2                   |
| 20      | H2 <sup>-</sup>     | Hall signal input   | 2                   |
| 21      | H3 <sup>+</sup>     | Hall signal input   | 2                   |
| 22      | H3 <sup>-</sup>     | Hall signal input   | 2                   |
| 23      | AMP—GND             | FG amplifier ground pin                                       |                     |
| 24      | IN1                 | FG amplifier 1 input  | 7                   |
| 25      | OUT1                | FG amplifier 1 output   | 7                   |
| 26      | IN2                 | FG amplifier 2 input  | 7                   |
| 27      | OUT2                | FG amplifier 2 output   | 7                   |
| 28      | AMP—V <sub>cc</sub> | FG amplifier power supply                                     |                     |
| 29      | ED / S              | Forward/stop/reverse mode switching input                     | 3                   |
| 30      | A3                  | Motor output  | 1                   |
| 31      | ATC                 | Driver ground pin   | 1                   |
| 32      | SUB—GND             | SUB ground pin, also serves as a radiation fin                |                     |

● Input/output circuits

1. Driver output

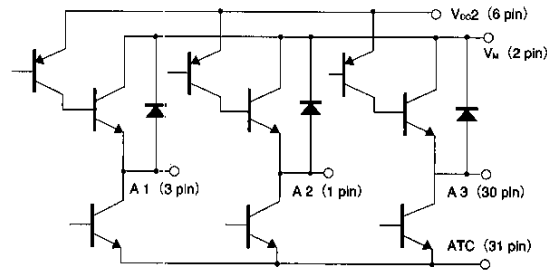

Fig. 1

2. Hall input

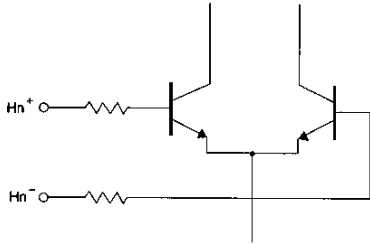

Fig. 2

3. ED/S

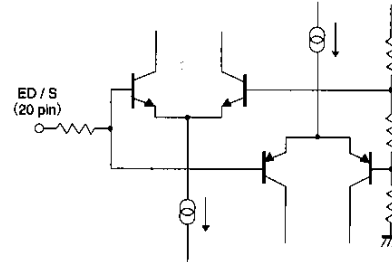

Fig. 3

4. Torque control input

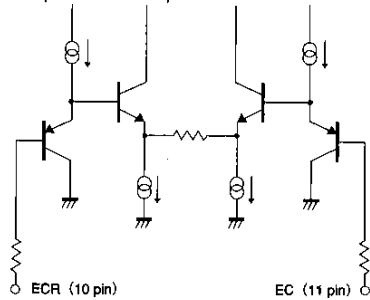

Fig. 4

5. Torque limit and current sensing

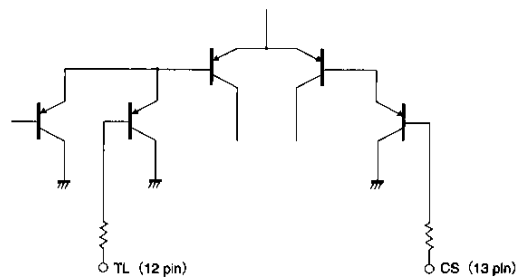

Fig. 5

6. Amplifier I/O

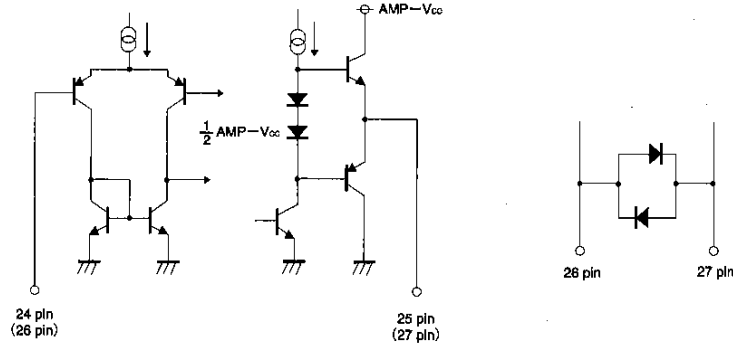

Fig. 6

●Electrical characteristics (unless otherwise noted,  $T_a=25^\circ\text{C}$ ,  $V_{CC1}=5\text{V}$ ,  $V_M=V_{CC2}=12\text{V}$ , AMP- $V_{CC}=12\text{V}$ )

| Parameter                                 | Symbol               | Min.           | Typ.           | Max.          | Unit          | Conditions   |
|---|----------------------|----------------|----------------|---------------|---------------|--|
| Circuit current                           | $I_{CC}$             | —              | 10             | 16            | mA            | $E_c=E_{CR}$ , ED/S=M, Input=L, L, H               |
| Torque control voltage                    | $E_c$                | 1              | —              | 4             | V             | $E_c$ input range                                  |
| Torque control voltage offset             | $E_{Cofs}$           | -110           | —              | +110          | mV            |  |
| Torque control dead zone                  | $E_{CDZ}$            | 50             | —              | 170           | mV            |  |
| Output idle voltage                       | $E_{Cidle}$          | —              | —              | 5             | mV            | Within the dead zone, ED/S = L                     |
| Output idle current                       | $I_{Eidle}$          | —              | —              | 2             | mA            | ED/S=M   |
| Torque control I/O gain                   | $G_{Io}$             | 0.26           | 0.32           | 0.38          | —             | $E_c=2.2\rightarrow 2.1\text{V}$ , input=(L, L, H) |
| Forward ON voltage                        | ED / F               | —              | —              | 0.9           | V             |  |
| Stop ON voltage                           | ED / S               | 1.3            | —              | 3.0           | V             |  |
| Reverse ON voltage                        | ED / R               | 3.5            | —              | —             | V             |  |
| Hall input voltage                        | $V_{HDC}$            | 1.2            | —              | 3.2           | V             |  |
| Hall input conversion offset              | $H_{Eofs}$           | -10            | —              | +10           | mV            |  |
| Hall input conversion offset differential | $\Delta H_{Eofs}$    | -15            | —              | +15           | mV            |  |
| TL-CS offset                              | TL-CS <sub>ofs</sub> | 10             | 35             | 65            | mV            |  |
| Ripple cancellation ratio                 | $V_{RCC}$            | 4.0            | 6.3            | 8.6           | %             | Input=(L, L, H) $\rightarrow$ (L, M, H)            |
| High-side output voltage                  | $V_{OH}$             | 0.9            | 1.3            | 1.70          | V             | $I_o=0.8\text{A}$                                  |
| Low-side output voltage                   | $V_{OL}$             | 0.95           | 1.3            | 1.65          | V             | $I_o=0.8\text{A}$                                  |
| Series regulator operating voltage        | $V_{REG}$            | $V_M$<br>-0.70 | $V_M$<br>-0.95 | $V_M$<br>-1.2 | V             | $E_c=1.5\text{V}$ , $V_M=V_{CC2}=15\text{V}$       |
| Series regulator current capacity         | $I_{REG}$            | 17             | 30             | —             | mA            | $E_c=0\text{V}$ , $V_{REG}=2\text{V}$              |
| Short-circuit detection operating voltage | $V_{off}$            | 60             | 90             | 120           | mV            |  |
| ~FG amplifier~                            |                      |                |                |               |               |  |
| Circuit current                           | AMP- $I_{CC}$        | —              | 1.1            | 3.0           | mA            |  |
| Bias voltage                              | $V_{BI}$             | 5.3            | 6.2            | 6.8           | V             |  |
| Input current (AMP1)                      | $I_{IN}$             | —              | 0.5            | 5.0           | $\mu\text{A}$ | $V_{IN}=1.0\text{V}$                               |
| High-side output voltage (AMP1)           | $V_{OHA}$            | —              | 1.0            | 1.5           | V             | $I_o=-0.5\text{mA}$                                |
| Low-side output voltage (AMP1)            | $V_{OLA}$            | —              | 1.0            | 1.5           | V             | $I_o=+0.5\text{mA}$                                |
| Open loop gain 1                          | $G_{V1}$             | 50             | —              | —             | dB            | $f=1\text{kHz}$                                    |
| Open loop gain 2                          | $G_{V2}$             | 28             | —              | —             | dB            | $f=20\text{kHz}$                                   |

●Circuit operation

(1) Pseudo-linear output and torque ripple cancellation

The IC generates a trapezoidal (pseudo-linear) output current, whose waveform phase is 30 degrees ahead of that of the Hall input voltage (Fig. 7).

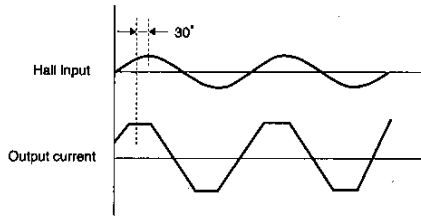

Fig. 7

The trapezoidal waveform of output current would create intermittence in the magnetic field generated by the 3-phase motor, and would result in an irregular rotation of the motor. To prevent this, the output waveform is obtained by superimposing a triangular wave on the trapezoidal wave (Fig. 7). This process is called torque ripple cancellation.

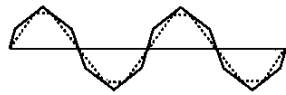

Fig. 8

(2) Torque control and reversal brake

The output current can be controlled by adjusting the voltage applied to the torque control pins (pins 10 and 11).

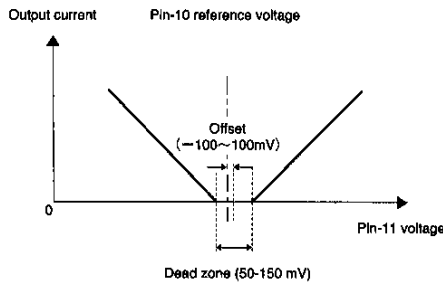

Fig. 9

These pins are the inputs to a differential amplifier. A reference voltage between 2.3~3.0V (2.5V recommended) is applied to pin 10.

A brake is applied to the motor as described in the following. When the motor is running, pin 11 is given a negative potential with respect to the reference potential. If the pin 11 potential becomes positive, the IC detects the rise of pin-11 potential above the reference potential and activates the motor direction detecting circuit.

The motor direction detecting circuit sends a signal to the motor direction setting circuit to reverse the motor direction. This causes a braking torque that depends on the pin 11 potential, so that the motor quickly reduces its speed. At the same time, the positive pin 11 potential is shifted to the reference potential, so that the motor stops smoothly.

(3) Output current sensing and torque limitation

Pin 31 is the ground pin for the output stage. To sense the output current, a resistor (0.5Ω recommended) is connected between pin 31 and the ground. The output current is sensed by applying the voltage developed across this resistor to pin 13 as a feedback.

The output current can be limited by adjusting the voltage applied to pin 12. The current is limited when pin 12 reaches the same potential as pin 13. The output current ( $I_{MAX}$ ) under this condition is given by :

$$I_{MAX} = \frac{V_{12P} - (TL - CS_{off})}{R_{31P}}$$

where  $R_{31P}$  is the value of the resistor connected between pin 31 and the ground,  $V_{12P}$  is the voltage applied to pin 12, and  $(TL - CS_{off})$  is the offset between the TL and CS pins.

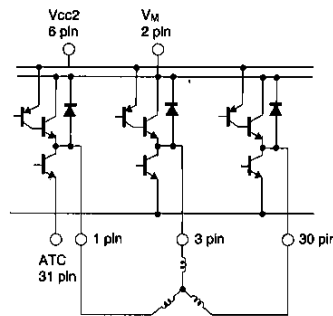

Fig.10 Output circuit

● Circuit operation

(4) Motor direction control (29 pin)

The motor mode is :

Forward when the pin 29 voltage is less than 0.9V,

Stop when the voltage is between 1.3~3.0V,

Reverse when the voltage is above 3.5V.

In the stop mode, high- and low-side output transistors are turned off, resulting in a high impedance state.

(5) Output transistor saturation prevention circuit

This circuit monitors the output voltage and maintain the operation of the output transistors below their saturation levels. Operating the transistors in the linear characteristic range provides good control over a wide range of current and good torque characteristics even during overloading.

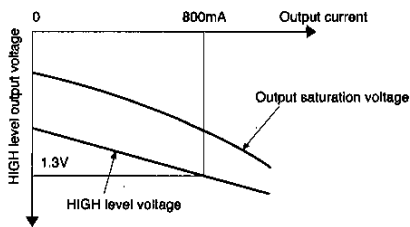

Fig.11 High level output voltage vs. output current (reference curves)

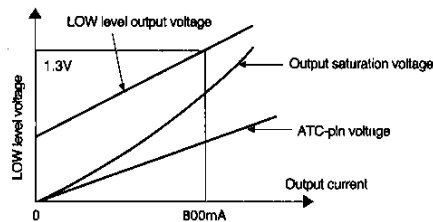

Fig.12 Low level output voltage vs. output current (reference curves)

(6) Series regulator

The BA6871BS has a series regulator output pin. The IC outputs a sink current according to the HIGH level output voltage detected.

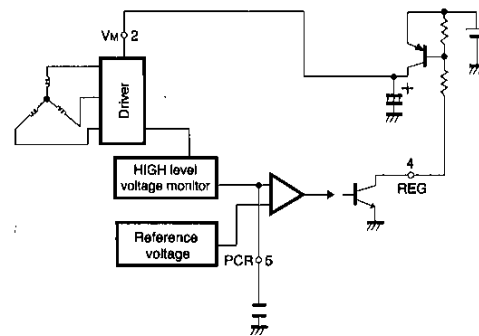

Fig.13

As shown in Fig. 13, the regulator circuit reduces the power consumed by the IC by reducing the collector-to-emitter (C-E) voltage of the driver transistors.

Nearly all the power dissipated by the IC is dissipated between the collectors and emitters of the output transistors. More power is consumed as the C-E voltage increases and as the output current increases.

The output transistor C-E voltage is equal to the difference between the supply voltage and the voltage applied to the motor. Because the voltage across the motor decreases with decreasing drive current, the C-E voltage must increase if the supply voltage is fixed.

Therefore, to improve the efficiency of the driver and to prevent the power rating of the IC being exceeded, the supply voltage must be varied in response to changes in the output current. The supply voltage is decreased at low current and increased at high current so that no excessive voltage is applied between the transistor collectors and emitters.

(7) Output-to-ground short-circuit detection

The motor output pins of the IC may be short-circuited to the ground by some fault conditions. A short-circuited output can destroy the output transistors because of excessive current, excessive voltage, or both. Even when a short-circuit condition does not completely destroy the device, it can still cause extreme overheating. To prevent this, the BA6871BS contains a short-circuit detection circuit that turns off the motor drive current if the output-to-ground potential becomes abnormally low.



● Application example

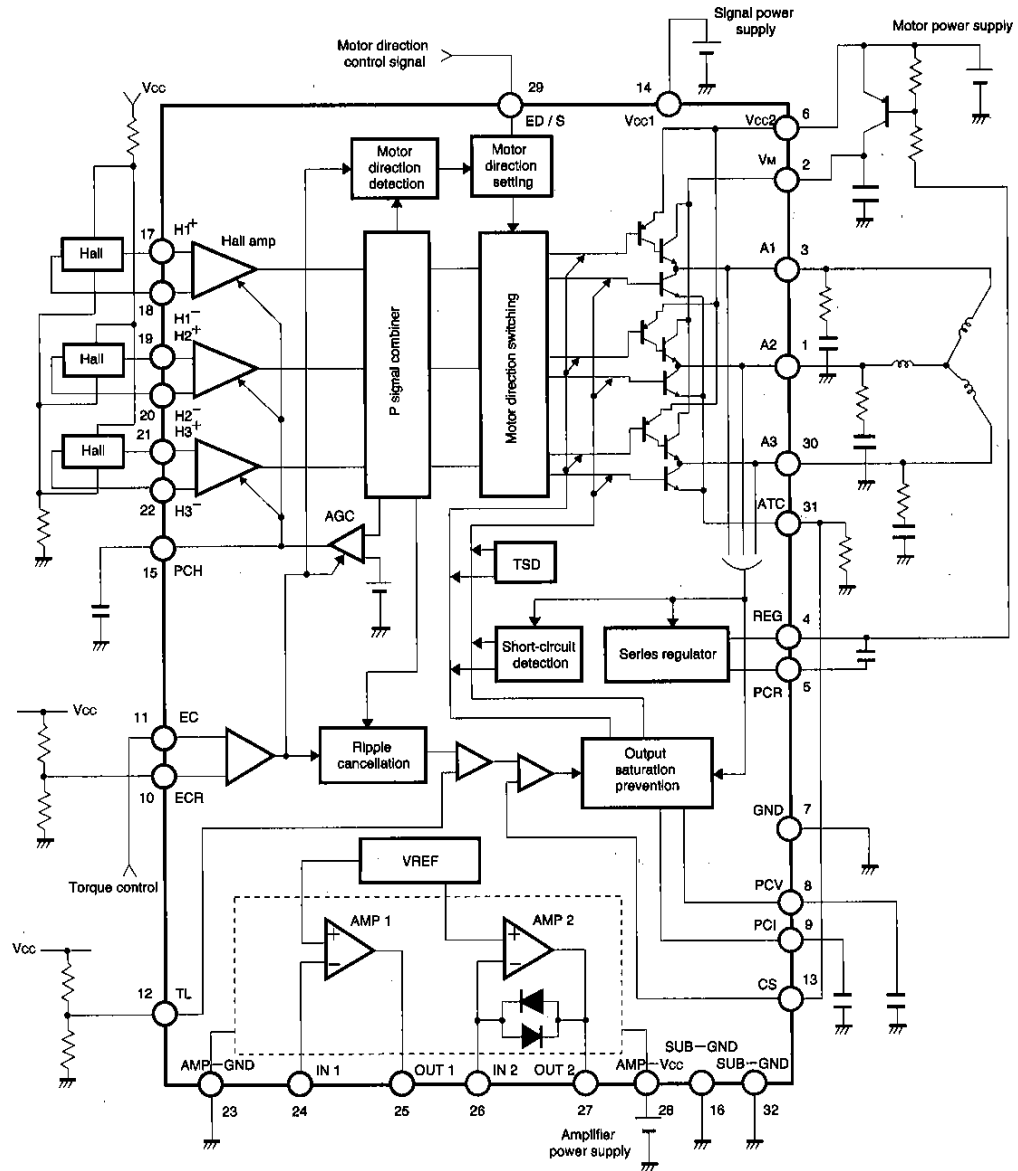

Fig.14

Three-Phase Full-Wave Motor Drivers for Capstan Motors

Motor Drivers for VCRs

● Operation notes

The BA6871BS has two thermal shutdown circuits (TSD1 and TSD2) to protect the IC. The typical shut-down temperatures are 175°C for TSD1 and 215°C for TSD2.

When the TSD1 is activated at an elevated chip temperature, the output pins (pins 1, 3, and 30) are set to the open state. TSD1 is functional against excessive power dissipation, output short-circuiting, and other irregularities in the output current, but does not work against overheating caused by high internal currents due to externally caused IC damage or pin-to-pin short-circuiting.

When TSD2 is activated at a higher chip temperature, the high- and low-side output transistors are turned on,

and the internal resistance between the motor power supply pin (2 pin) and the output ground pin (31 pin) drops to less than 3 Ω. The motor power supply current ( $I_M$ ) is then given by

$$I_M = \frac{V_M [V]}{R_M + R_{31P} + 3 [\Omega]}$$

where

$I_M$  is the motor supply current

$V_M$  is the motor supply voltage,

$R_M$  is the motor power supply output resistance,

$R_{31P}$  is the pin-31 resistance.

In your application, make sure to connect between the motor power supply and pin 2 a circuit breaker that operates at currents less than  $I_M$ .

● Electrical characteristic curves

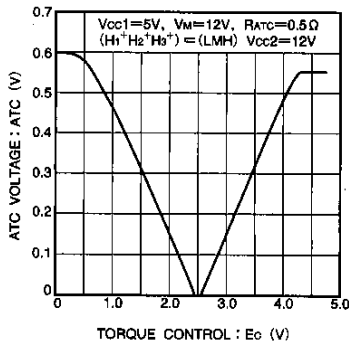

Fig.15 Output voltage vs. Torque control voltage ( I )

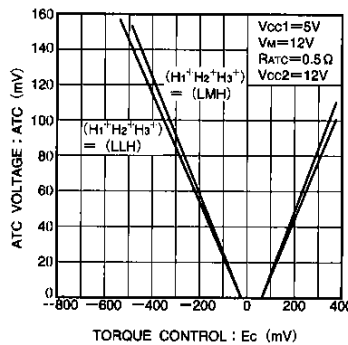

Fig.16 Output voltage vs. Torque control voltage ( II )

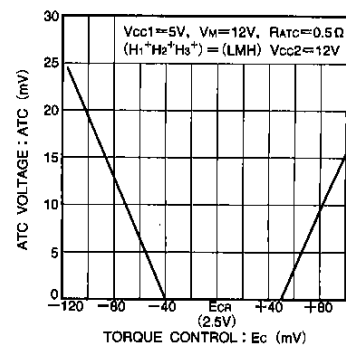

Fig.17 Output voltage vs. Torque control voltage ( III )

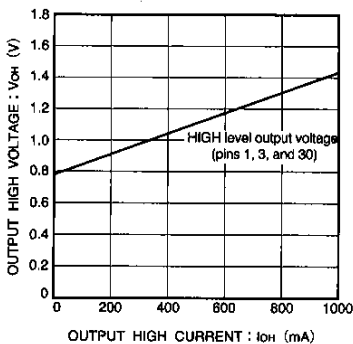

Fig.18 High level output voltage vs. High level output current

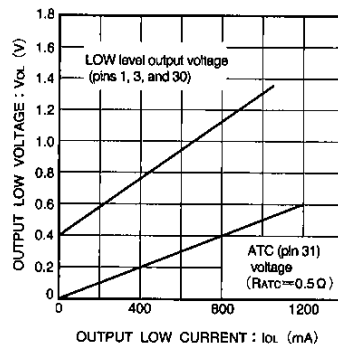

Fig.19 Low level output voltage vs. Low level output current

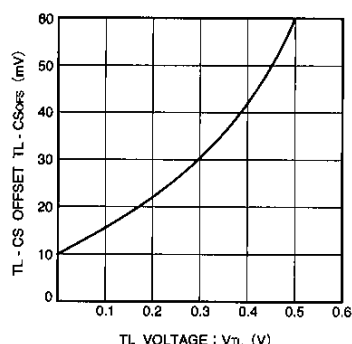

Fig.20 TL-CS offset vs. VTL voltage

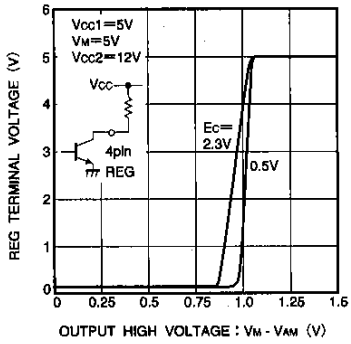

Fig.21 REG-pin voltage vs. High level output voltage

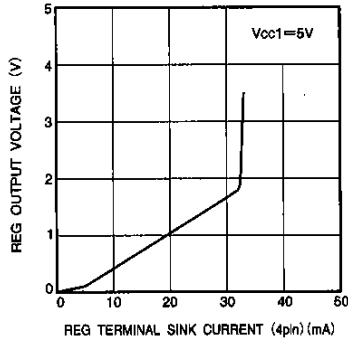

Fig.22 REG-pin output voltage vs. REG-pin sink current

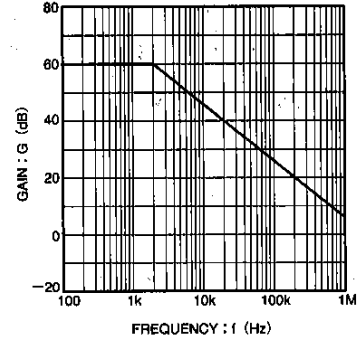

Fig.23 Gain vs. frequency for the FG amplifier

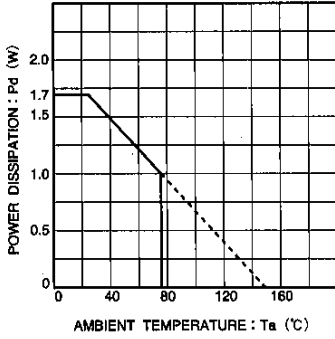

Fig.24 Power dissipation curve

● External dimensions (Units: mm)

