

4-channel BTL driver for CD players

BA6297AFP

The BA6297AFP is a 4-channel BTL driver for CD player actuators and motors. The preamplifier has both positive and negative input pins and output pins, making this IC suited to a broad range of applications.

●Applications
CD players

●Features

- 1) 4-channel BTL driver.
- 2) HSOP 28-pin package allows for miniaturization of applications.
- 3) Internal thermal shutdown.
- 4) Driver gain is adjustable with a single attached resistor.
- 5) Both positive and negative input pins, for adaptability for a wide range of inputs (including negative phase input).

●Absolute maximum ratings (Ta = 25°C)

Parameter	Symbol	Limits	Unit
Power supply voltage	V _{cc}	18	V
Power dissipation	P _d	1.7*	W
Operating temperature	T _{opr}	-40~+80	°C
Storage temperature	T _{stg}	-55~+150	°C

*Reduced by 13.6 mW for each increase in Ta of 1°C over 25°C.
When mounted on a 50 mm × 50 mm × 1.0 mm paper phenol board

●Recommended operating conditions (Ta = 25°C)

Parameter	Symbol	Min.	Typ.	Max.	Unit
Operating power supply voltage	V _{cc}	6.0	—	9.0	V

●Block diagram

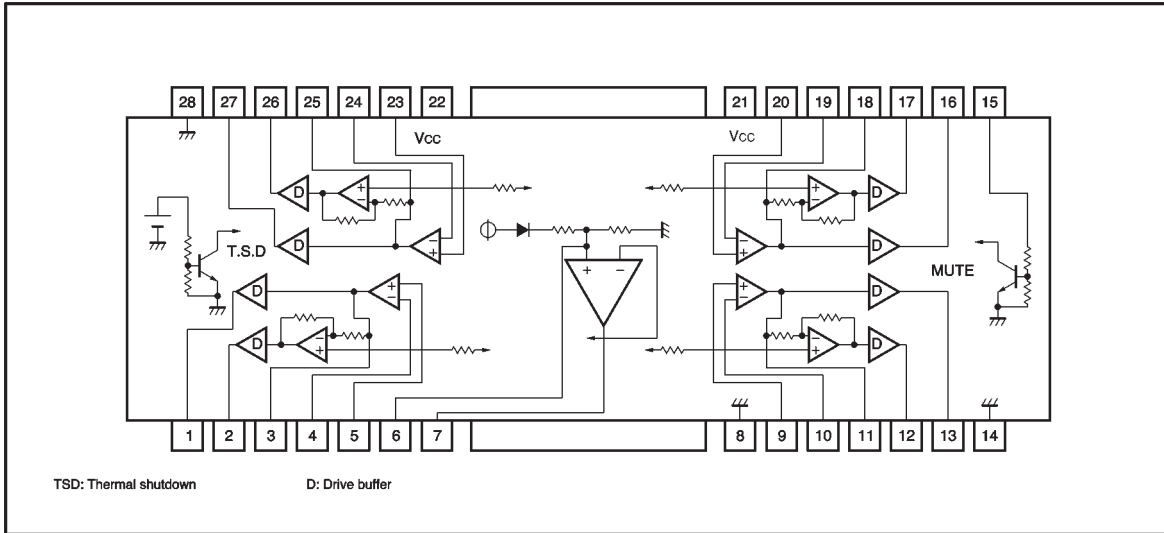

●Electrical characteristics (unless otherwise noted, $T_a = 25^\circ\text{C}$, $V_{CC} = 8\text{V}$, $f = 1\text{kHz}$, $R_L = 8\Omega$)

Parameter	Symbol	Min.	Typ.	Max.	Unit	Conditions	Measurement Circuit
Quiescent current dissipation	I_Q	6.5	11	15.5	mA	No load	Fig.5
Output offset voltage	V_{OO}	-30	-	30	mV		
Maximum output voltage, high	V_{OHD}	5.2	5.6	-	V	$V_{INDC}=1\text{V}$	
Maximum output voltage, low	V_{OLD}	-	1.3	1.55	V	$V_{INDC}=7\text{V}$	
Input bias current	I_B	-	-	300	nA		
Synchronous input voltage	V_{ICM}	1.6	-	6.8	V	Preamplifier, buffer configured	
Preamplifier V_{OH}	V_{OHP}	6.6	7.1	-	V	$V_{INDC}=\text{GND}$, $R_L=\infty$	
Preamplifier V_{OL}	V_{OLP}	-	0.8	1.3	V	$V_{INDC}=V_{CC}$, $R_L=\infty$	
Preamplifier I_{OH}	I_{OHP}	2	-	-	mA	Preamplifier output 100 Ω at GND	
Preamplifier I_{OL}	I_{OLP}	5	-	-	mA	Preamplifier output 100 Ω at V_{CC}	
Ripple rejection ratio	RR	-	70	-	dB	$V_{IN}=-20\text{dBV}$, 100Hz	
Slew rate	SR	-	2	-	V/ μs	100 kHz square wave, 3V _{P-P} output	
Bias pin voltage	V_{ref}	3.65	3.80	3.95	V		
Bias voltage variation	ΔV_{ref}	-30	-	25	mV	1 mA sink / source	
Mute-off voltage	V_{MUTE}	2.0	-	-	V		

● Electrical characteristic curves

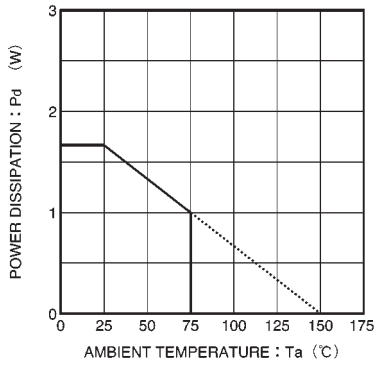

Fig. 1 Thermal derating curve

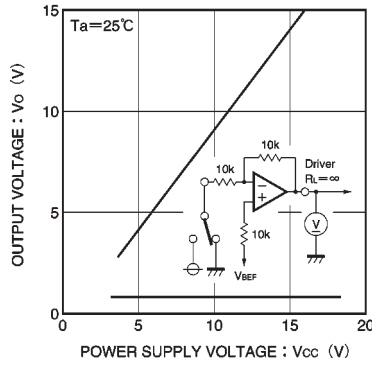

Fig. 2 Power supply voltage vs. output amplitude

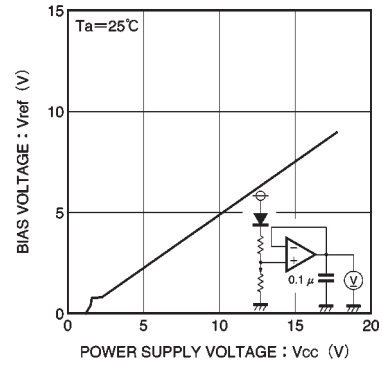

Fig. 3 Power supply voltage vs. bias pin voltage

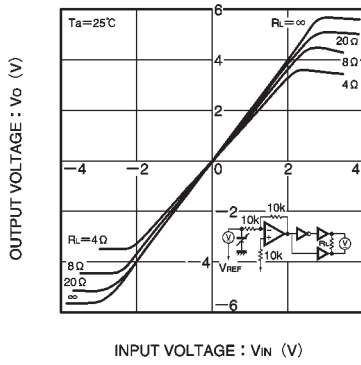

Fig. 4 Driver I / O characteristics

● Measurement circuit

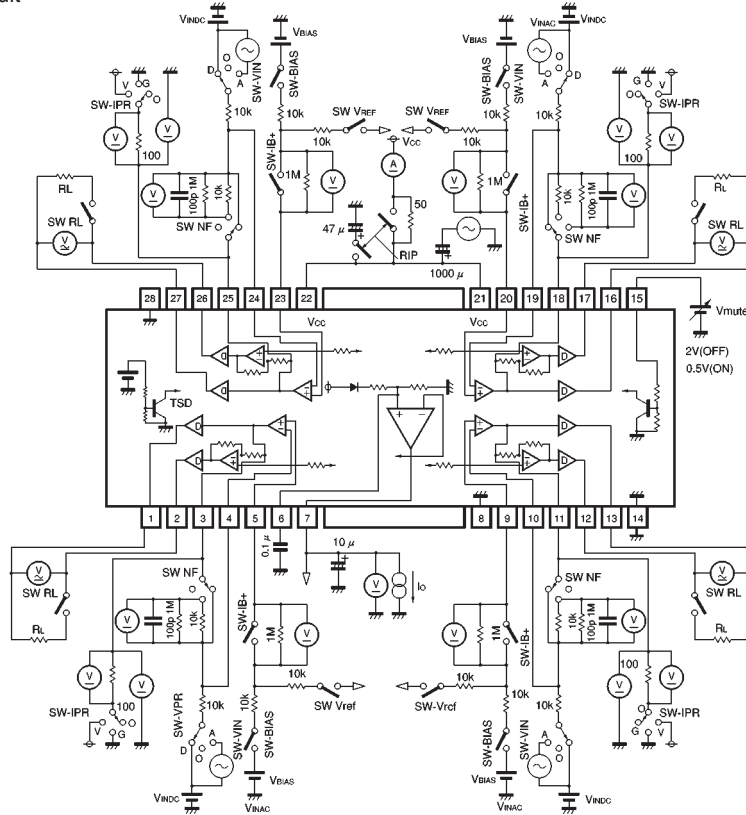

Fig.5

Table 1 Measurement circuit switch

Parameter	Switch position								Note
	V _{IN}	BIAS	V _{REF}	NF	RL	I _{PR}	I _B (+)	R _{IP}	
I _Q	D	ON	ON	10k	OFF	O	ON	ON	
V _{OO}	↓	↓	↓	↓	ON	↓	↓	↓	
V _{OHD}	↓	OFF	↓	↓	↓	↓	↓	↓	V _{INDC} =1V、7V
V _{OLD}	↓	↓	↓	↓	↓	↓	↓	↓	V _{INDC} =1V、7V
I _B	O	↓	↓	1M	OFF	↓	OFF	↓	Both pin outputs: 1 MΩ
V _{ICM}	↓	ON	OFF	SHORT	↓	↓	ON	↓	
V _{OHP}	↓	OFF	ON	10k	↓	↓	↓	↓	V _{INDC} =GND
V _{OLP}	↓	↓	↓	↓	↓	↓	↓	↓	V _{INDC} =V _{CC}
I _{OHP}	↓	↓	↓	SHORT	↓	G	↓	↓	
I _{OLP}	↓	↓	↓	↓	↓	V	↓	↓	
RR	D	ON	↓	10k	ON	O	↓	OFF	
V _{ref}	O	↓	↓	↓	↓	↓	↓	ON	
Δ V _{ref}	↓	OFF	OFF	↓	OFF	↓	↓	↓	

* Unless otherwise noted, V_{BIAS} = V_{INDC} = 2.5 V

●Circuit operation

The BA6297AFP comprises a 4-channel driver, internal bias amplifier, mute pin and thermal shutdown.

(1) Driver

The driver uses a buffer to output one of the outputs from its preamplifier with no modification, and uses an inversion amplifier to invert the other output before sending it to the driver buffer. The inversion amplifier's reference is the bias voltage generated internally (pin 7 voltage), and so the preamplifier output must make the zero level equal to the internal bias voltage. See Figs. 7 and 8 for examples.

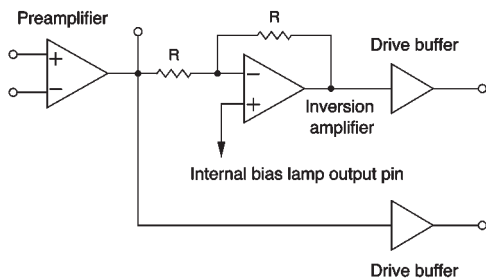

Fig. 6 Driver block

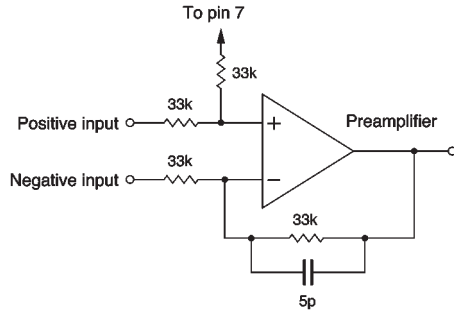

Fig. 7 Differential input

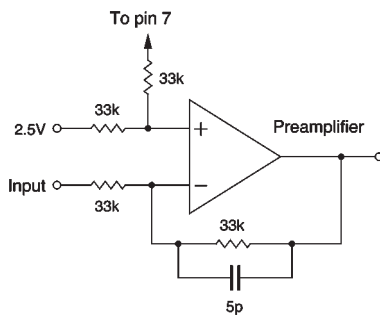

Fig. 8 Input centered on 2.5 V

(2) Internal bias amplifier

Configured as shown in Fig. 9. The internal bias voltage (V_{ref}) is calculated thus :

$$V_{ref} = \frac{V_{CC} - V_F}{2}$$

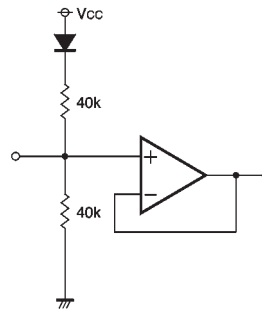

Fig. 9 Internal bias block

(3) Mute pin (pin 15)

The output current is muted when this pin receives the low level or a high impedance. Set the pin voltage at high during normal operation.

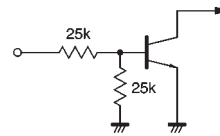

Fig. 10 The mute pin

(4) Thermal shutdown

The BA6297AFP has an internal thermal shutdown circuit. Output current is muted when the chip temperature exceeds 175°C (typically).

● Operation notes

- (1) The BA6297AFP has an internal thermal shutdown circuit. Output current is muted when the chip temperature exceeds 175°C (typically).
- (2) If the mute pin (pin 15) voltage is opened or lowered below 0.5V, the output current will be muted. Pin 2 should be pulled up above 2.0V during normal use. During muting, the output pins remain at the internal bias voltage, roughly $(V_{CC} - V_F) / 2$.

- (3) Be sure to connect the IC to a 0.1μF bypass capacitor to the power supply, at the base of the IC.
- (4) The radiating fin is connected to the packages internal GND, but should also be connected to an external ground.

● Application example

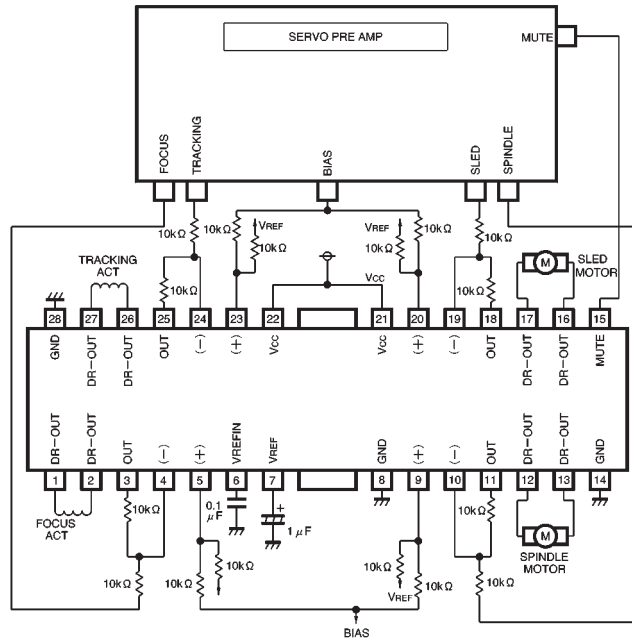

Fig. 11

● External dimensions (Units: mm)

