

4-channel BTL driver for CD players

BA5934FP

The BA5934FP is a 4-channel BTL driver developed to drive CD player motors and actuators. Perfect for compact applications with the use of the HSOP 28-pin power package.

●Applications

CD players, CD-ROM

●Features

- 1) In addition to internal drivers for the focus coil, tracking coil, and sled motor, it also contains a driver for the loading motor.
- 2) Perfect for compact applications with the use of the HSOP 28-pin power package.
- 3) Requires few external components.
- 4) Driver gain is adjustable with a single externally connected resistor.
- 5) Internal thermal shutdown circuit.
- 6) External mute pin enables the muting of the output current for channel 4.

●Absolute maximum ratings (Ta = 25°C)

Parameter	Symbol	Limits	Unit
Power supply voltage	Vcc	18	V
Power dissipation	Pd	1.7 *	W
Operating temperature	Topr	-35~+85	°C
Storage temperature	Tstg	-55~+150	°C

* When mounted on a 70mm × 70mm × 1.6mm glass epoxy board with copper foil coverage of less than 3%.
Reduced by 13.6mW for each increase in Ta of 1°C over 25°C.

●Recommended operating conditions (Ta = 25°C)

Parameter	Symbol	Min.	Typ.	Max.	Unit
Power supply voltage	Vcc	4.5	—	13.2	V

● Block diagram

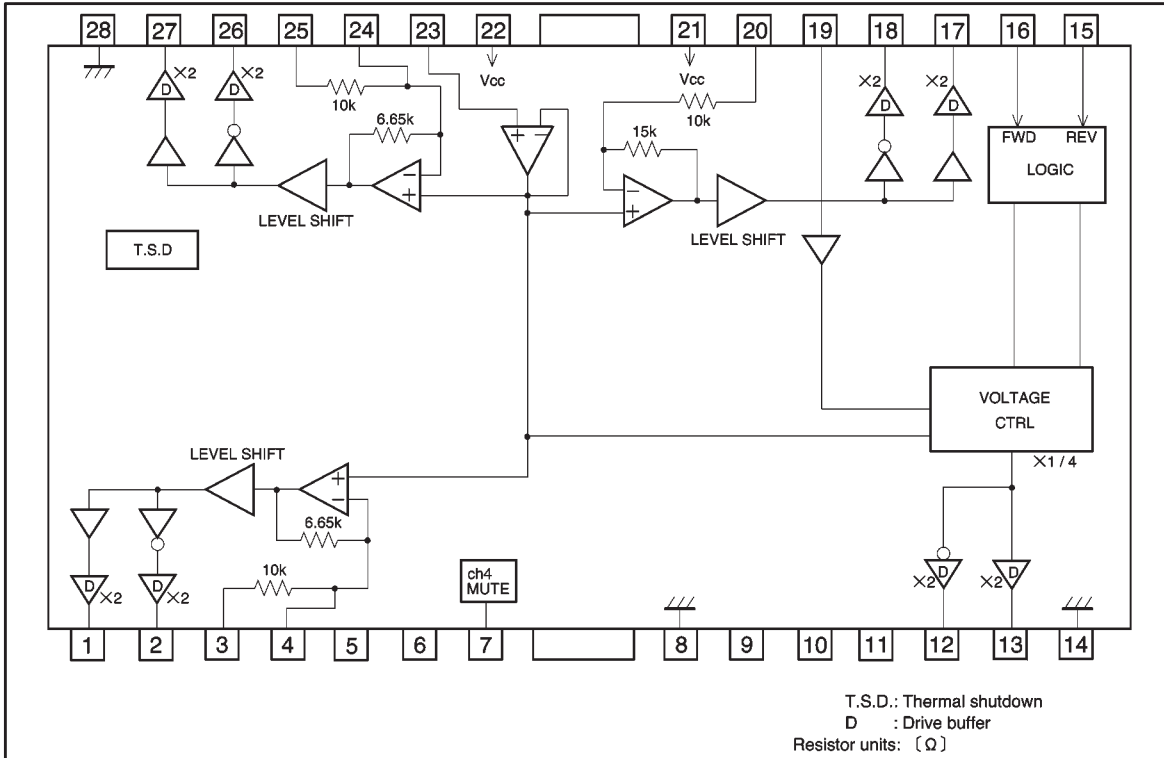

● Pin descriptions

Pin No.	Pin name	Function	Pin No.	Pin name	Function
1	OUT1-1	Channel 1 negative output	15	REV	Loading motor reverse input
2	OUT1-2	Channel 1 positive output	16	FWD	Loading motor forward input
3	IN1-1	Channel 1 input	17	OUT3-1	Channel 3 negative output
4	IN1-2	Input for channel 1 gain adjustment	18	OUT3-2	Channel 3 positive output
5	N.C.	N.C.	19	LDIN	Loading motor input
6	N.C.	N.C.	20	IN3	Channel 3 input
7	MUTE	Mute control for channel 4	21	Vcc	Vcc
8	GND	GND	22	Vcc	Vcc
9	N.C.	N.C.	23	VrefIN	Bias amplifier input
10	N.C.	N.C.	24	IN4-2	Input for channel 4 gain adjustment
11	N.C.	N.C.	25	IN4-1	Channel 4 input
12	OUT2-2	Loading motor positive output	26	OUT4-2	Channel 4 positive output
13	OUT2-1	Loading motor negative output	27	OUT4-1	Channel 4 negative output
14	GND	Substrate GND	28	GND	Substrate GND

Note 1: Positive output and negative output are the polarities with respect to the input.
 Note 2: Loading positive output and loading negative output are the polarities with respect the mode.

● Input / output circuits

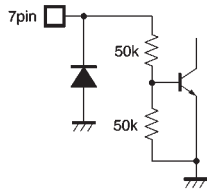
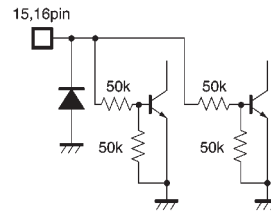
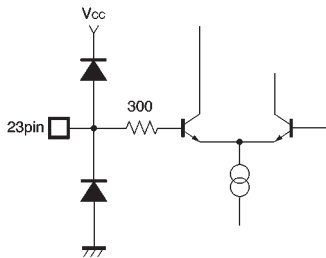
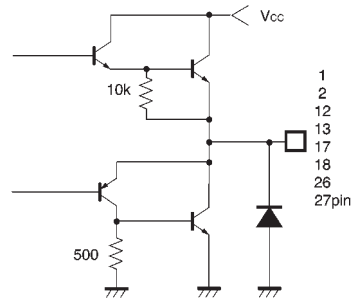
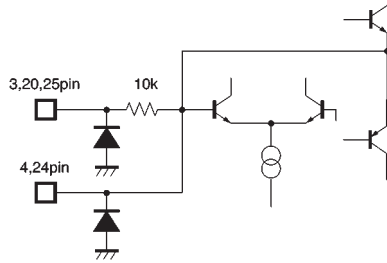

●Electrical characteristics (unless otherwise noted, Ta = 25°C, Vcc = 8V, RL = 8Ω, VBIAS = 2.5V)

Parameter	Symbol	Min.	Typ.	Max.	Unit	Conditions
Circuit current	Icc	—	6.3	9.8	mA	No load
〈All drivers except the loading driver〉						
Output offset voltage	VOO	−40	—	40	mV	ch1, ch3, and ch4 drivers
Maximum output pin-to-pin voltage 1	VOH1	4.7	5.6	—	V	VBIAS=4V, VIN=8V
Maximum output pin-to-pin voltage 2	VOH2	—	−5.6	−4.7	V	VBIAS=4V, VIN=0.7V
Closed-loop voltage gain 1	GVC1	7.4	8.4	9.4	dB	VIN=VBIAS±0.5V (ch1, 4)
Closed-loop voltage gain 2	GVC2	14.2	15.2	16.2	dB	VIN=VBIAS±0.5V (ch3)
Ripple rejection	RR	—	60	—	dB	VIN=0.1Vrms, 100Hz
Slew rate	SR	—	2.0	—	V / μs	100Hz rectangular wave, 3Vp-p output
Mute on voltage	VMON	2.0	—	—	V	
Mute off voltage	VMOFF	—	—	0.5	V	
Mute output voltage	VMO	−0.5	—	0.5	mV	tm=125 μs*3
〈Loading driver〉						
Voltage between outputs F	VOF	2.0	2.6	3.2	V	Vcc=8V, RL=8Ω, LDIN=2.5V
Voltage between outputs R	VOR	−3.1	−2.5	−1.9	V	
Output voltage range F	VOMF	2.3	3.1	—	V	Vcc=5V, RL=8Ω, LDIN=4.5V*1
Output voltage range R	VOMR	—	−3.1	−2.3	V	
Output load regulation F1	ΔVF1	—	250	500	mV	Vcc=8V, LDIN=3.0V I=100→400mA*2
Output load regulation R1	ΔVR1	—	250	500	mV	
Output load regulation F2	ΔVF2	—	600	850	mV	Vcc=5V, LDIN=OPEN I=100→400mA*2
Output load regulation R2	ΔVR2	—	600	850	mV	
Power supply voltage regulation F	ΔVFL	−500	—	500	mV	Vcc=5V→13V, RL=∞
Power supply voltage regulation R	ΔVRL	−500	—	500	mV	
Output offset voltage	VOOL	−50	—	50	mV	During braking; voltage between outputs
〈Controller FWD REV pins〉						
Input high level voltage 1	VIH1	2.0	—	—	V	FWD (16pin), REV (15pin) Voltage at input pins
Input low level voltage 1	VIL1	—	—	0.5	V	
Input high level current	IiH	—	—	500	μA	VIN=5V
Input low level current	IiL	—	—	500	μA	VIN=0V

©Not designed for radiation resistance.

*1 Even if the loading input (pin 19) LDIN is open, VOMF and VOMR remain approximately the same.

*2 ΔVF1 and ΔVR1 perform load regulation with 3.0V output without the output clipping.

In order to open the input during reduced supply voltage of 5V, ΔVF2 and ΔVR2 clip the output.
Load regulation is performed in this condition.

● Measurement circuit

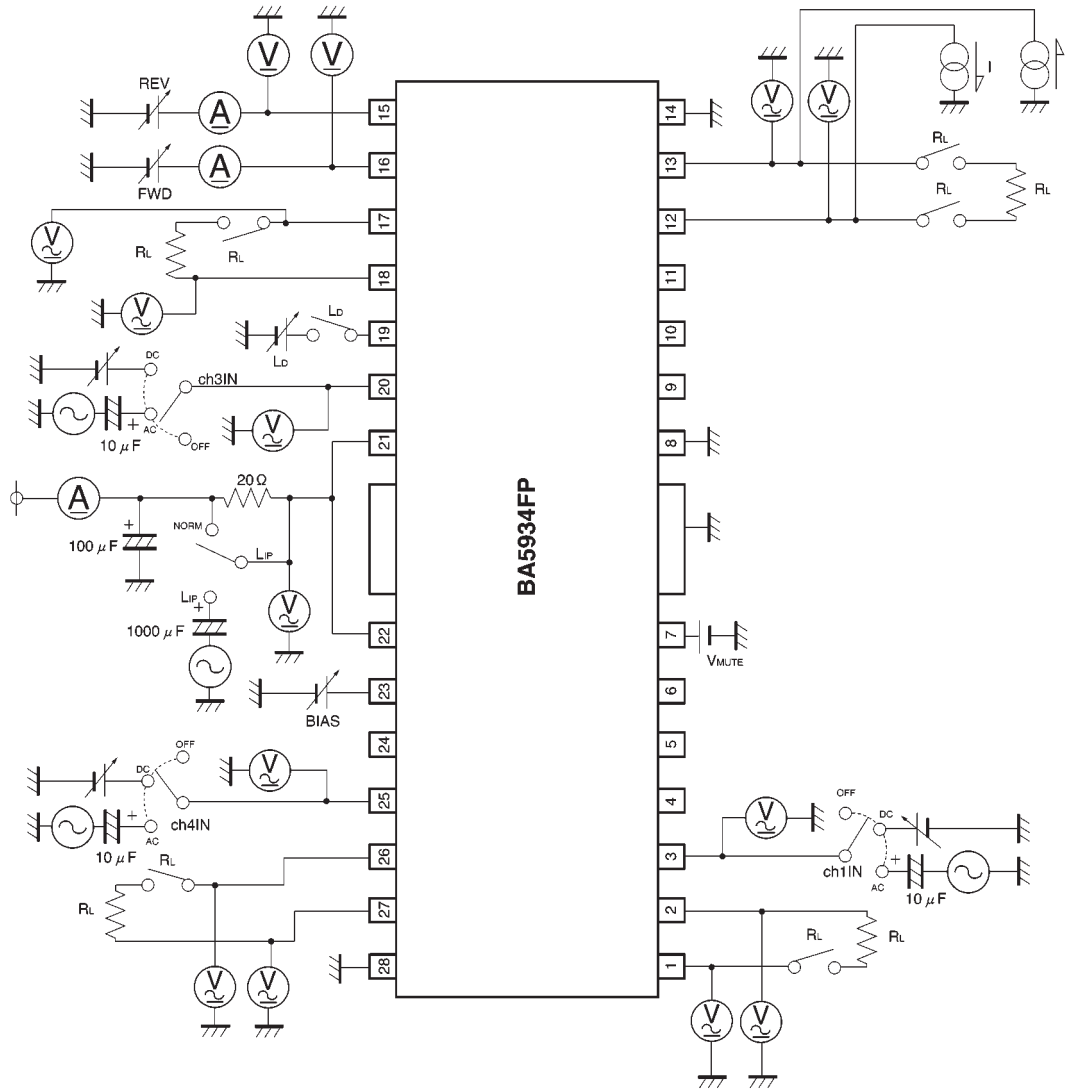

Fig.1

● Circuit operation

(1) Driver block

The input is the focus and tracking error signals from the servo pre-amplifier and the control signals for the motor system.

The input signal is normally centered at 2.5V, and at the pre-amplifier, it undergoes V/I conversion to generate the current corresponding to the input voltage. This is then passed through a resistor and sent to the internal reference voltage block.

This results in the output from the pre-amplifier being the signal at the center of the internal reference voltage. Furthermore, at the V/I conversion, forward and reverse phases are generated and the BTL output is then gained through the driver buffer.

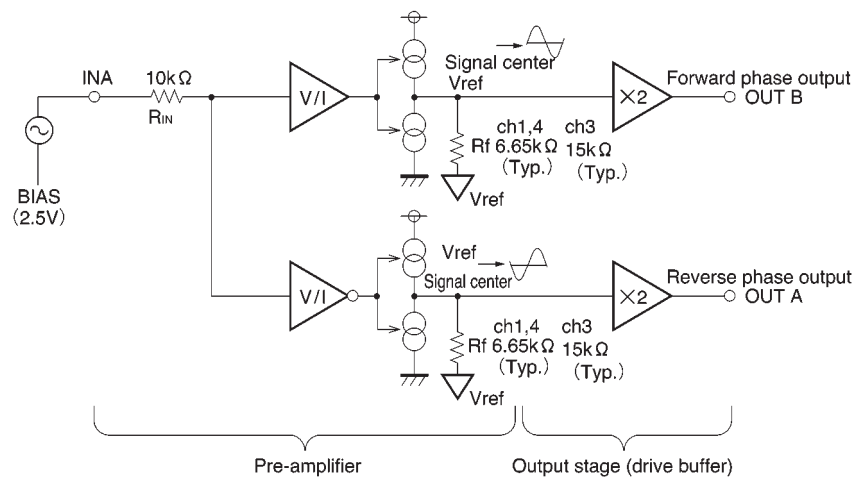

Fig.2

(2) Output mode switch for loading motor driver ($V_{CC} = 8V$)

FWD	REV	Loading output	Refer to
L	L	High impedance	Fig.3
	H	Reverse	Fig.4
H	L	Forward	Fig.5
	H	Brake	Fig.6

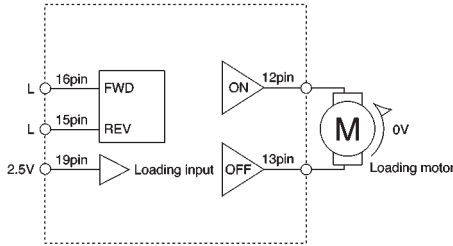

Fig.3

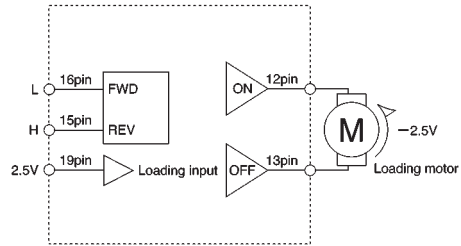

Fig.4

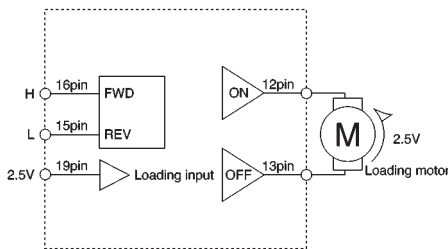

Fig.5

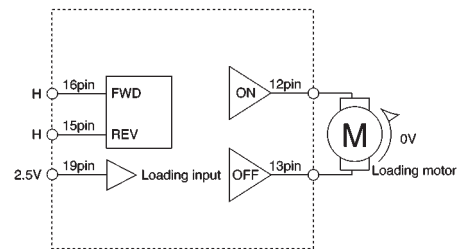

Fig.6

Note: Loading driver gain is 0dB.

(3) Voltage setting for loading motor driver (ex: forward mode)

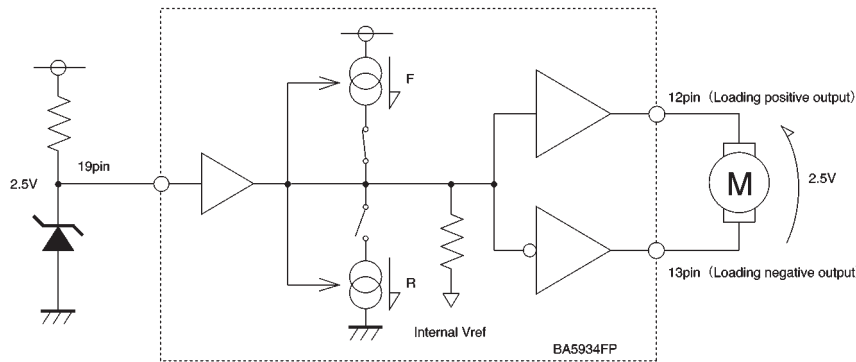

Fig.7

Input voltage=output voltage (gain 0dB)

* When setting the output voltage from the loading driver, even if an output voltage is set that exceeds the maximum output voltage with respect to the power supply voltage, the output will not exceed the maximum output voltage. If a voltage is set that is under the maximum output voltage, the example above is applicable. Also, by having the loading input (pin 19) open, the maximum output voltage with respect to the power supply voltage is output.

●Application example

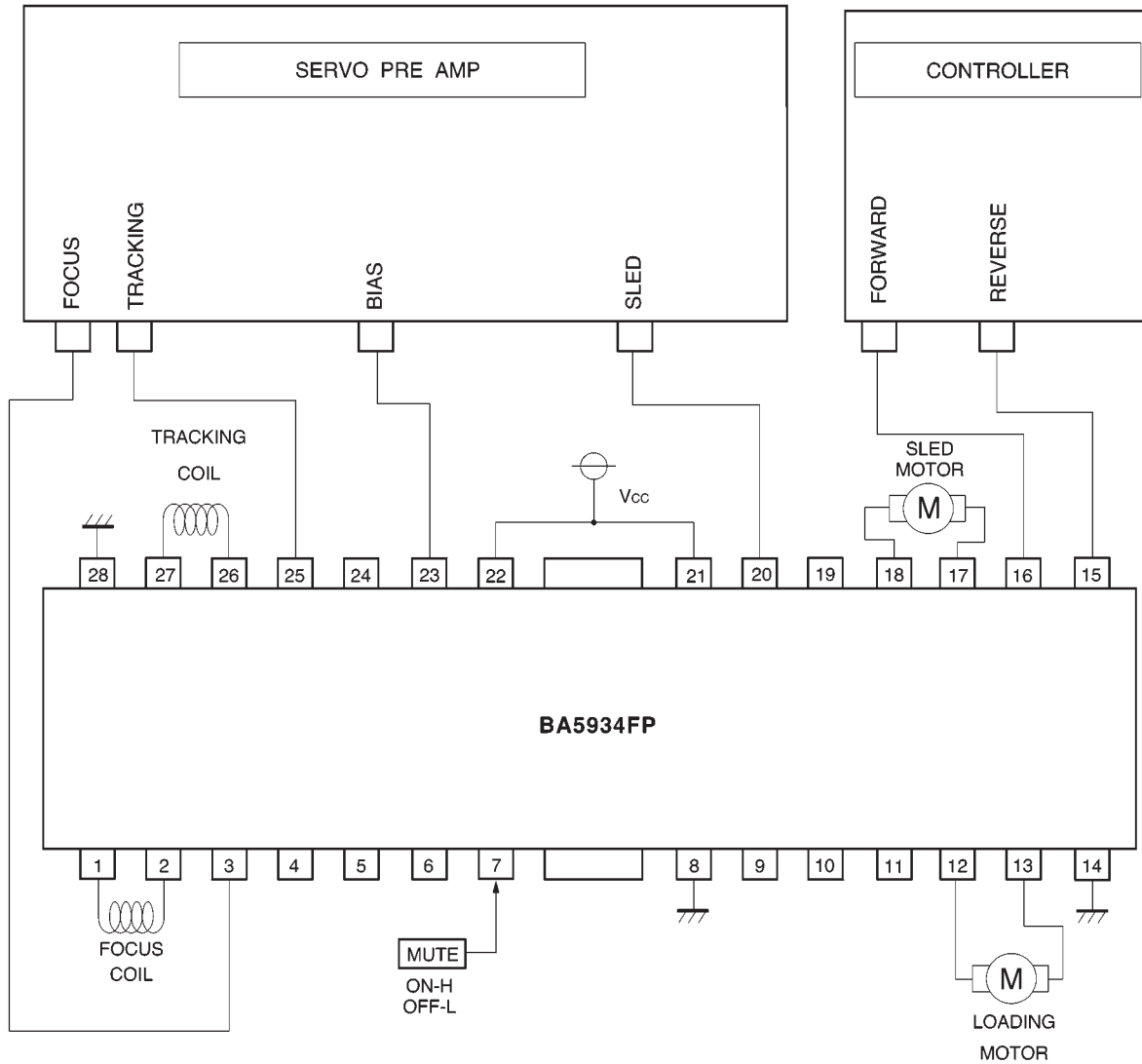

Fig.8

●Operation notes

(1) The BA5934FP contains a thermal shutdown circuit. When the chip temperature reaches 175°C (Typ.), the output current is muted.

(2) By having the mute pin (pin 7) voltage pulled up to 2.0V or greater, you can mute the output current for channels 1 and 4. For normal conditions, have pin 7 open or at 0.5V or below.

The figure below is the timing chart for the high-impedance mute.

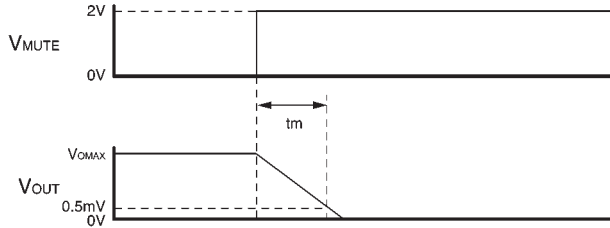

$V_{CC}=12V$
 $BIAS=2.5V$
 $V_{OUT}=V_{OMAX}$
 $R_L=8\Omega$

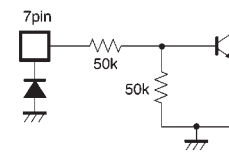

$tm \leq 125 \mu s$ *3 Equivalent circuit diagram for mute pin

(3) If the voltage of the bias pin (pin 23) drops below 1.4V (Typ.), outputs are muted. For normal conditions, have the voltage above 1.6V and below 6.5V.

(5) Connect a bypass capacitor (approx. 0.1μF) between the bases of the power supply pins of this IC.

(4) If the voltage of the thermal shutdown or bias pin drops, the mute is activated; however, in these situations, only the drivers are muted. Also, the output pin voltage becomes the internal bias voltage (approx. $(V_{CC} - VF)/2$).

(6) Even though the radiation fins are connected to ground within the package, be sure to also connect them to a ground externally as well.

●Electrical characteristic curves

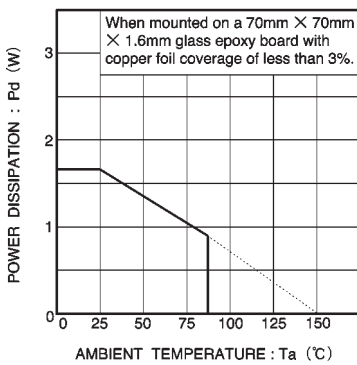

Fig.9 Thermal derating curve

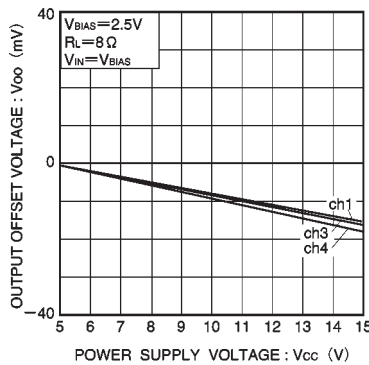

Fig.10 Power supply voltage vs. output offset voltage

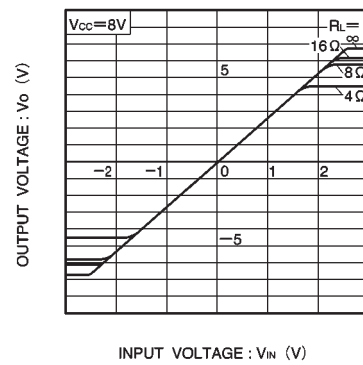

Fig.11 Channels 1 and 4 I / O characteristics (during load regulation)

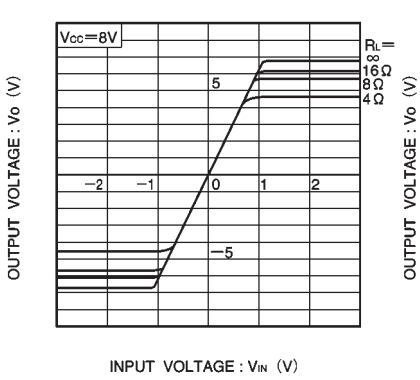

Fig.12 Channel 3 I/O characteristics (during load regulation)

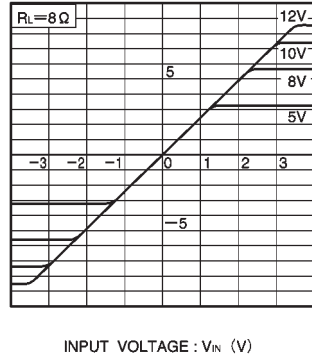

Fig.13 Channels 1 and 4 I/O characteristics (during Vcc regulation)

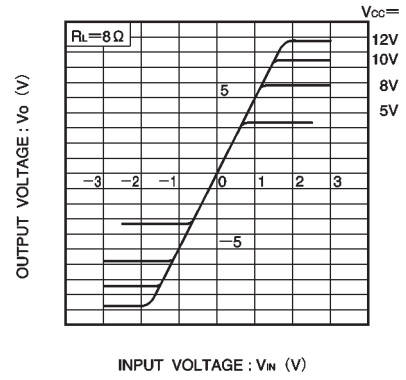

Fig.14 I/O characteristics (during Vcc regulation)

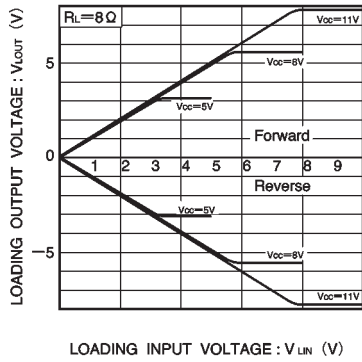

Fig.15 Loading driver I/O characteristics

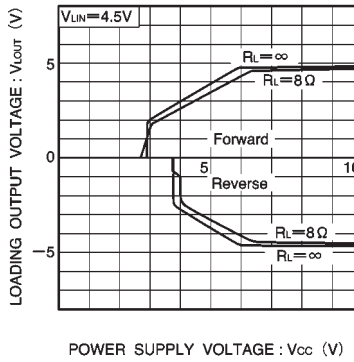

Fig.16 Loading output vs. power supply voltage

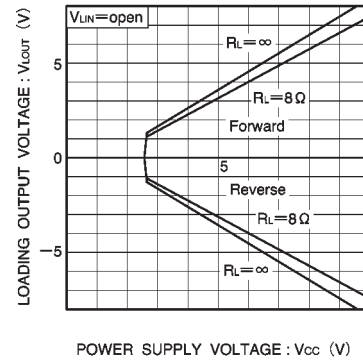

Fig.17 Loading voltage vs. power supply voltage

● External dimensions (Units: mm)

