

# BA3910B

## Power supply, standard voltage

The BA3910B is a power supply used in car audio systems.

### Features

- available in an SIP-M12 package
- multiple voltages available from the same IC
  - 5.6 V (microcontroller)
  - 8.7 V (×3; FM, AM, and COM)
- internal overflow voltage protection circuit provides protection from surges from the ACC or BACKUP supply pins
- all output circuits use a PNP transistor with a low saturation voltage
- internal output overload protection circuit prevents damage to the IC in the event the load is short circuited
- internal thermal overload also protects the IC

### Applications

- car audio systems

### Dimensions (Units : mm)

#### BA3910B (SIP-M12)

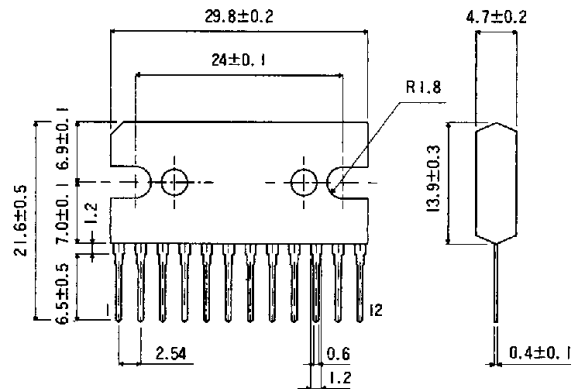

**Block diagram**

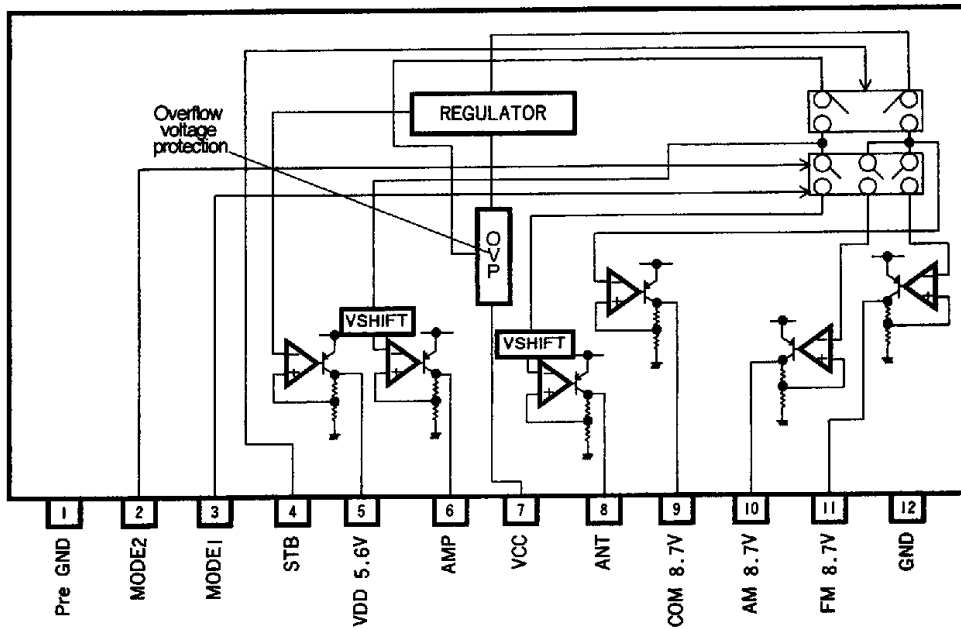

**Table 1 Pin description**

Pin no.	Pin name	Function
1	Pre GND	Small current ground
2	MODE1	AM output, ANT output rise pin
3	MODE2	FM output or AM output switch pin
4	STB	COM output, AMP output rise pin
5	VDD 5.6 V	VDD, 4.5 V output pin
6	AMP	Remote amplifier driving power supply (V <sub>CC</sub> in series)
7	VCC	Power supply pin
8	ANT	Antenna driving power supply (V <sub>CC</sub> in series)
9	COM 8.7 V	Common power supply for the power system, electronic synchronization and variable capacitance COM 8.7 V output
10	AM 8.7 V	AM reception power supply, 8.7 V
11	FM 8.7 V	FM reception power supply, 8.7 V output
12	GND	Large current system, substrate GND

**Figure 1 Input and output equivalent circuits**

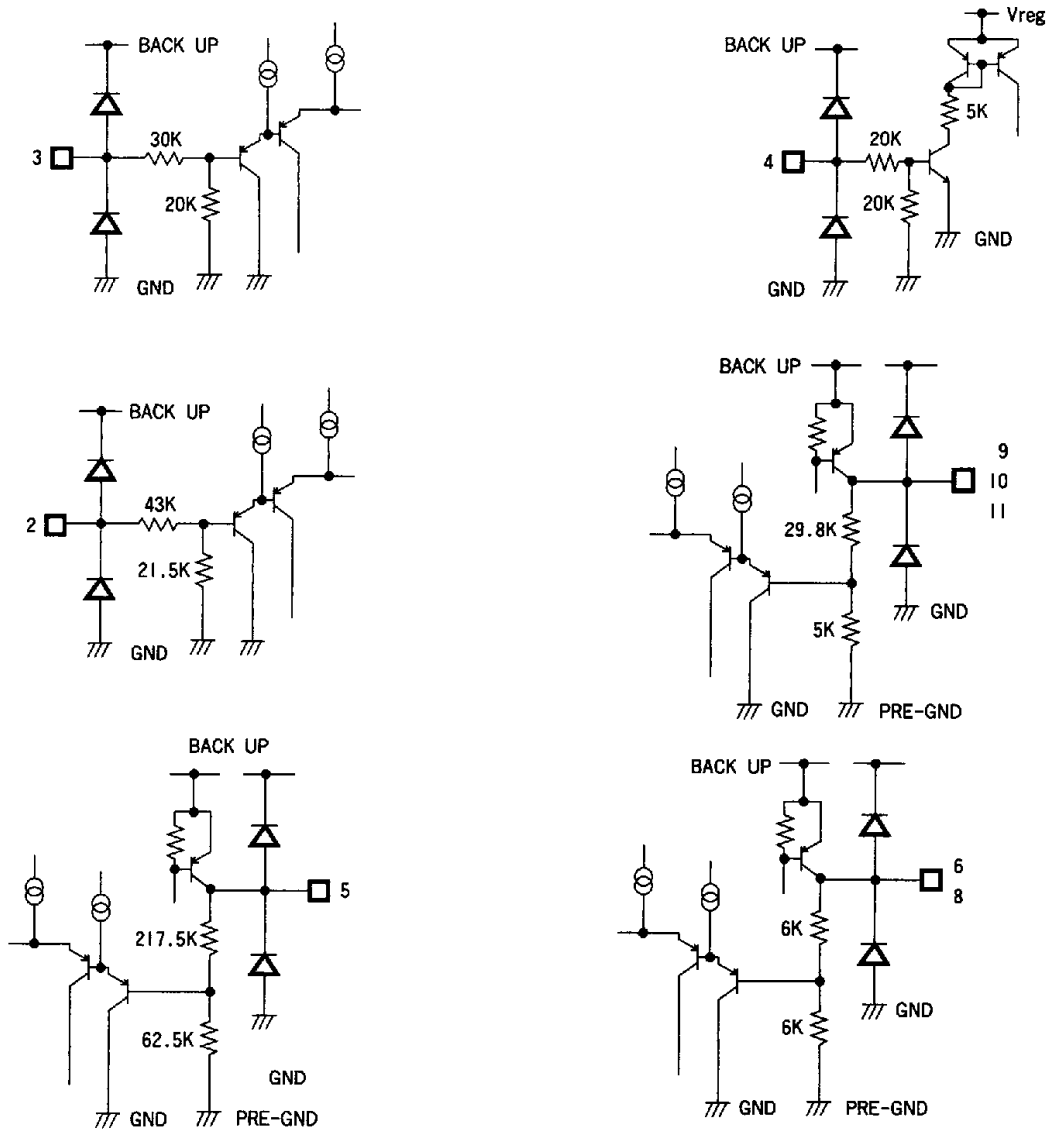

**Absolute maximum ratings ( $T_a = 25^\circ\text{C}$ )**

Parameter	Symbol	Limits	Unit	Conditions
Applied voltage	$V_{CC}$	24	V	
Power dissipation	$P_d$	3000	mW	Reduce power by 30 mW/°C for each degree above 25°C.
Peak applied voltage	$V_{CC}$ PEAK	50	V	$t_r \geq 1$ ms, maximum supply time is < 200 ms
Operating temperature	$T_{opr}$	-30 ~ +85	°C	
Storage temperature	$T_{stg}$	-55 ~ +150	°C	

**BA3910B** System power supply, BA3900 & BA3910 series

**Recommended operating conditions ( $T_a = 25^\circ\text{C}$ )**

Parameter	Symbol	Range	Unit
Power supply voltage	$V_{CC}$	10 ~ 16	V

**Electrical characteristics (unless otherwise noted,  $T_a = 25^\circ\text{C}$ ,  $V_{CC} = 13.2\text{ V}$ ) (Sheet 1 of 2)**

Parameter	Symbol	Min	Typical	Max	Unit	Conditions	Test figure
Standby circuit current	$I_{st}$		0.55	0.80	mA	Stand by pin = 0 V	2
<b>Output 1 (<math>V_{DD}</math>)</b>							
Output voltage	$V_{O1}$	5.30	5.60	5.90	V	$I_{O1} = 80\text{ mA}$	2
Line regulation	$\Delta V_{O11}$		100	200	mV	Back up= 10 ~ 16 V, $I_{O1} = 80\text{ mA}$	
Load regulation	$\Delta V_{O12}$		30	150	mV	$I_{O1} = 0 \sim 80\text{ mA}$	
Dropout voltage	$\Delta V_{O13}$		0.3	0.7	V	$I_{O1} = 80\text{ mA}$	
Output current	$I_{O1}$	100	150		mA	$V_{O1} \geq 5.3\text{ V}$	
Ripple rejection ratio	R.R <sub>1</sub>	43	47		dB	$f = 100\text{ Hz}$ , $V_{RR} = -10\text{ dBV}$	3
<b>Output 2 (COM)</b>							
Output voltage	$V_{O2}$	8.25	8.70	9.15	V	$I_{O2} = 120\text{ mA}$	2
Line regulation	$\Delta V_{O21}$		100	200	mV	$V_{CC} = 10 \sim 16\text{ V}$ , $I_{O2} = 120\text{ mA}$	
Load regulation	$\Delta V_{O22}$		50	180	mV	$I_{O2} = 0 \sim 120\text{ mA}$	
Dropout voltage	$\Delta V_{O23}$		0.4	0.7	V	$I_{O2} = 120\text{ mA}$	
Output current	$I_{O2}$	150	200		mA	$V_{O2} \geq 8.25\text{ V}$	
Ripple rejection ratio	R.R <sub>2</sub>	40	45		dB	$f = 100\text{ Hz}$ , $V_{RR} = -10\text{ dBV}$	3
<b>Output 3 (AMP)</b>							
Line regulation	$\Delta V_{O31}$		0.5	0.9	V	$I_{O3} = 400\text{ mA}$	2
Load regulation	$\Delta V_{O32}$		300	600	mV	$I_{O3} = 0 \sim 400\text{ mA}$	
Output current	$I_{O3}$	500	650		mA	$V_{O3} \geq 12.3\text{ V}$	
<b>Output 4 (ANT)</b>							
Line regulation	$\Delta V_{O41}$		0.5	0.9	V	$I_{O4} = 400\text{ mA}$	2
Load regulation	$\Delta V_{O42}$		300	600	mV	$I_{O4} = 0 \sim 400\text{ mA}$	
Output current	$I_{O4}$	500	650		V	$I_{O4} \geq 12.3\text{ V}$	

System power supply, BA3900 & BA3910 series **BA3910B**

critical characteristics (unless otherwise noted,  $T_a = 25^\circ\text{C}$ ,  $V_{CC} = 13.2\text{ V}$ ) (Sheet 2 of 2)

Parameter	Symbol	Min	Typical	Max	Unit	Conditions	Test figure
<b>Output 5 (AM)</b>							
Output voltage	$V_{O5}$	8.25	8.70	9.15	V	$I_{O5} = 120\text{ mA}$	2
Line regulation	$\Delta V_{O51}$		100	200	mV	$V_{CC} = 10 \sim 16\text{ V}$ , $I_{O5} = 120\text{ mA}$	
Load regulation	$\Delta V_{O52}$		50	180	mV	$I_{O5} = 9 \sim 120\text{ mA}$	
Output voltage	$\Delta V_{O53}$		0.4	0.7	V	$I_{O5} = 120\text{ mA}$	
Output current	$I_{O5}$	150	200		mA	$V_{O5} \geq 8.25\text{ V}$	
Common mode rejection ratio	R.R5	40	45		dB	$f = 100\text{ Hz}$ , $V_{RR} = -10\text{ dBV}$	3
<b>Output 6 (FM)</b>							
Output voltage	$\Delta V_{O6}$	8.25	8.70	9.15	V	$I_{O6} = 200\text{ mA}$	2
Line regulation	$\Delta V_{O61}$		100	200	mV	$V_{CC} = 10 \sim 16\text{ V}$ , $I_{O6} = 200\text{ mA}$	
Load regulation	$\Delta V_{O62}$		50	180	mV	$I_{O6} = 0 \sim 200\text{ mA}$	
Output voltage	$\Delta V_{O63}$		0.4	0.7	V	$I_{O6} = 200\text{ mA}$	
Output current	$I_{O6}$	250	350		mA	$V_{O6} \geq 8.25\text{ V}$	
Common mode rejection ratio	R.R6	40	45		dB	$f = 100\text{ Hz}$ , $V_{RR} = -10\text{ dBV}$	3
<b>Standby input</b>							
Standby level	$V_{th1-1}$			1.1	V		2
Wake level	$V_{th1-2}$	1.7			V		
Start current, high	$I_{in1}$	100	175	250	$\mu\text{A}$	$V_{th1} = 5\text{ V}$	
<b>SW input 2</b>							
Standby level	$V_{th2-1}$			1.6	V		2
Wake level	$V_{th2-2}$	2.4			V		
Start current, high	$I_{in2}$	40	90	140	$\mu\text{A}$	$V_{th2} = 5\text{ V}$	
<b>SW input 1</b>							
ON level	$V_{th3-1}$			1.1	V		2
ON level	$V_{th3-2}$	2.7			V		
Start current, HIGH	$I_{in3}$	50	100	150	$\mu\text{A}$	$V_{th3} = 5\text{ V}$	

**Note:** Ensure circuit output current is less than the maximum value

# BA3910B System power supply, BA3900 & BA3910 series

## Test circuits

Figure 2 Test circuit for each pin

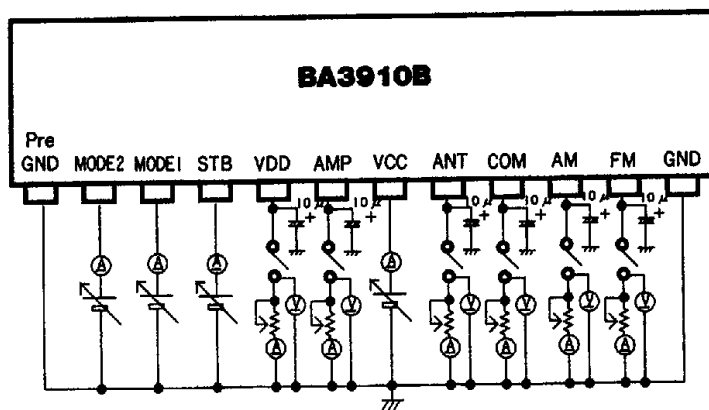
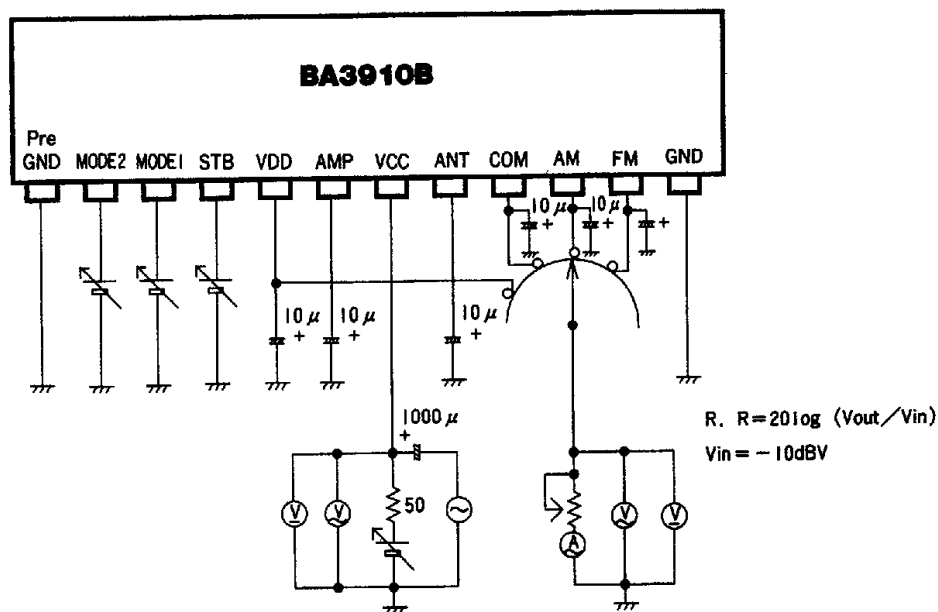
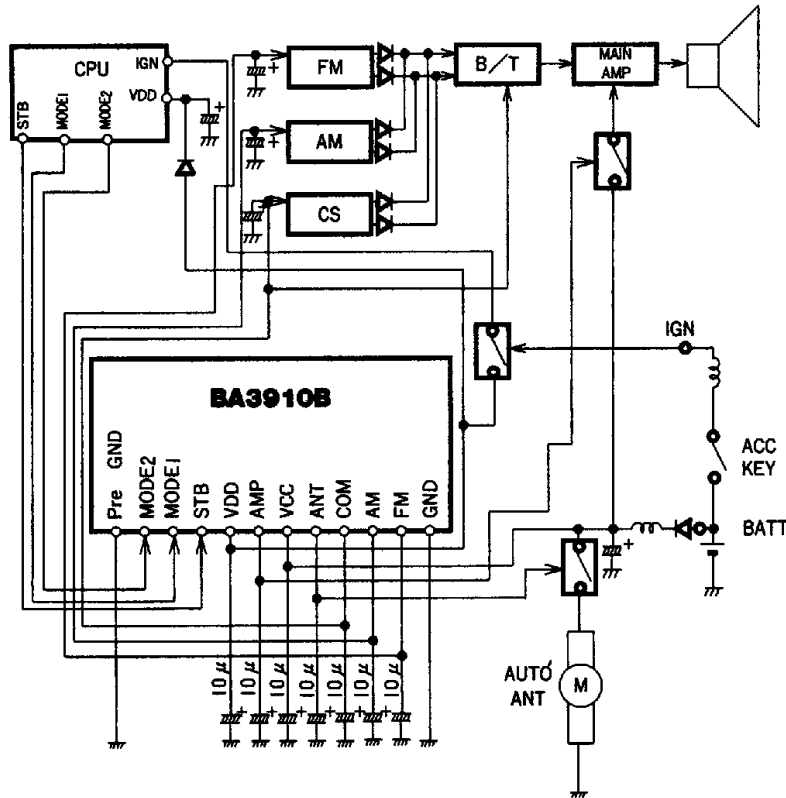

Figure 3 Ripple rejection rate test circuit



**Figure 4 Application example**



cuit operation

**Figure 5 Timing chart**

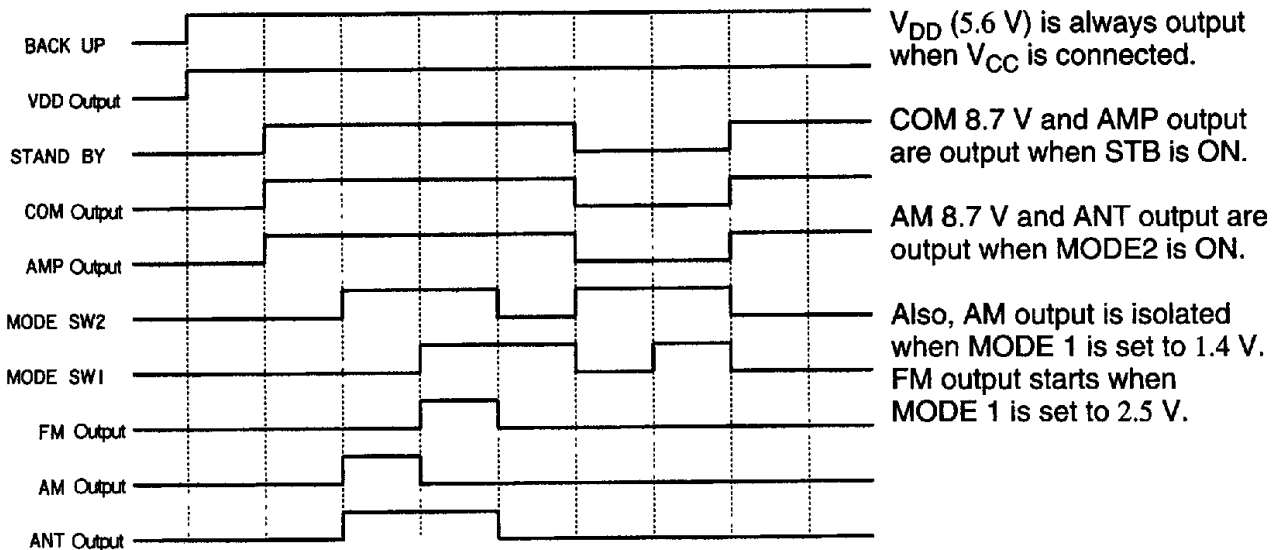
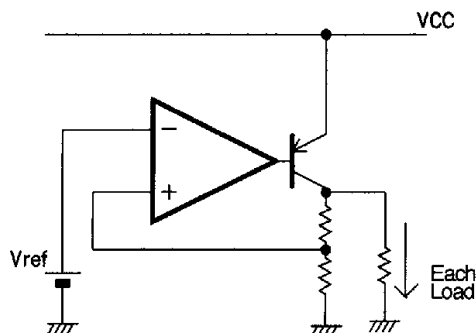

Figure 6 Determining maximum power consumption ( $P_{max}$ )



Power consumed by  $V_{DD}$  (5.6 V)

$$P_1 = (A - 5.6) \times I_1 + \left( \frac{I_1}{20} + \frac{I_1}{10} \right) A$$

Power consumed by COM8.7 V

$$P_2 = (A - 8.7) \times I_2 + \left( \frac{I_2}{30} + \frac{I_2}{10} \right) A$$

Power consumed by AMP

$$P_3 = (0.5 \times I_3) \times I_2 + \left( \frac{I_3}{100} + \frac{I_3}{10} \right) A$$

Power consumed by ANT

$$P_4 = (0.5 \times I_4) \times I_2 + \left( \frac{I_4}{100} + \frac{I_4}{10} \right) A$$

Power consumed by AM8.7 V

$$P_5 = (A - 8.7) \times I_5 + \left( \frac{I_5}{30} + \frac{I_5}{10} \right) A$$

Power consumed by FM8.7 V

$$P_6 = (A - 8.7) \times I_6 + \left( \frac{I_6}{50} + \frac{I_6}{10} \right) A$$

Power consumed internally by each circuit (circuit current  $\cong$  5 mA)

$$P_7 = V_{CC} \times \text{circuit current}$$

$P_{max} = P_1 + P_2 + P_3 + P_4 + (P_5 \text{ or } P_6, \text{ whichever is larger})$   
 where A = maximum output voltage for  $V_{CC}$

- $I_1$  = maximum output current for  $V_{SS}$
- $I_2$  = maximum output current for COM
- $I_3$  = maximum output current for AMP
- $I_4$  = maximum output current for ANT
- $I_5$  = maximum output current for AM
- $I_6$  = maximum output current for FM

## Precautions for use

### Application example

The application circuit in Figure 4 is recommended for use. Make sure to confirm the adequacy of the characteristics. When using the circuit with changes to the external circuit constants, make sure to leave an adequate margin for external components including static and transitional characteristics as well as dispersion of the IC. Note that ROHM cannot provide adequate confirmation of patents.

### Operating power supply

When operating at normal voltages and at ambient temperature, most circuit functions are guaranteed. The characteristic values cannot be absolutely guaranteed for all parameters. However, there are no sudden changes of the characteristics within these ranges.



**Voltage overload protection circuit**

The voltage overload protection circuit turns OFF the output when the potential difference between  $V_{CC}$  (pin 7) and GND (pin 12) exceeds about 26 V (at normal temperature). Make sure to use the IC within this range.

**Preventing oscillation at each output and the ripple filter capacitor**

To prevent oscillation, connect a capacitor between the  $V_{DD}$  (pin 5), AMP (pin 6), ANT (pin 8), COM (pin 9), AM (pin 10), and FM (pin 11) output pins and the GND. ROHM recommends using a tantalum capacitor with a low thermal characteristic.

**Current overload protection circuit**

A current overload protection circuit is installed on the  $V_{DD}$  (pin 5), AMP (pin 6), ANT (pin 8), COM (pin 9), AM (pin 10), and FM (pin 11) outputs based on their respective current capacity. This prevents damage to the IC in the event that the load is short circuited.

This protection circuit limits the current in the form of a "7" (see Figures 8 and 9). It is designed with a margin so that even if a large current suddenly flows through the large capacitor in the IC, the current is restricted and latching is prevented.

However, these protection circuits are only good for preventing accidental damage. Make sure your design does not cause the protection circuit to operate continuously (for instance: clamping at an output of 1 Vf or greater: below 1 Vf, the overload circuit operates). The capacitor has negative temperature characteristics.

**Thermal overload**

A thermal overload circuit is installed to prevent thermal damage. When the thermal overload circuit operates, all outputs, except  $V_{DD}$ , are put in the OFF state. When the temperature drops about 25°C, the circuit is restored.

**Circuit structure of each output**

The  $V_{DD}$  (pin 5), AMP (pin 6), ANT (pin 8), COM (pin 9), AM (pin 10), and FM (pin 11) outputs consist of PNP power transistors. A protection circuit ensures that when the  $V_{CC}$  (pin 7) voltage falls, the IC is not damaged, even if the output voltage from the external output capacitor is greater than the  $V_{CC}$  voltage.

**Grounding**

The ground shown in the application circuit has an adequately short pattern for the GND (pin 12) pin. Make sure to arrange these traces and other outputs in a pattern that prevents mutual interference.

**ASO**

Although this IC has many types of protection circuits built in, the ASO may still be exceeded under certain conditions. When ASO is exceeded, the IC will be destroyed. Be careful never to exceed the ASO.

Electrical characteristic curves

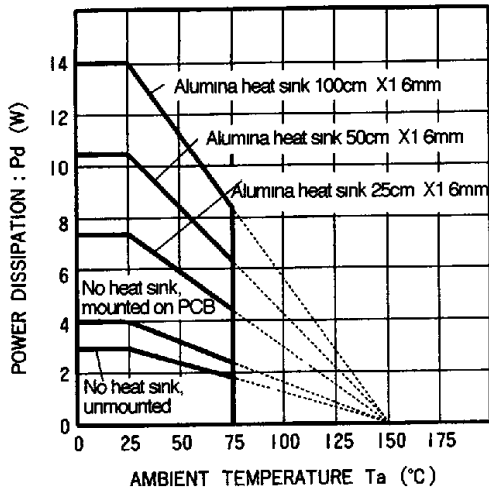

Figure 7

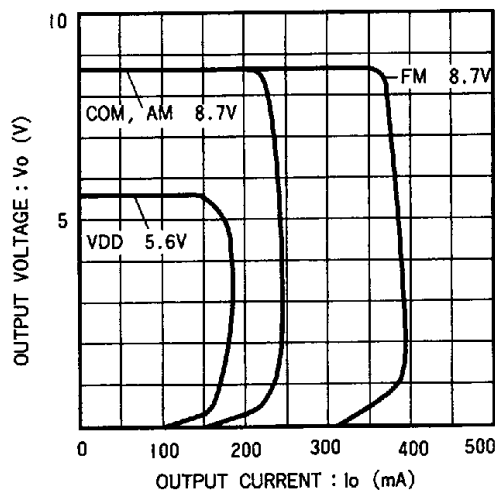
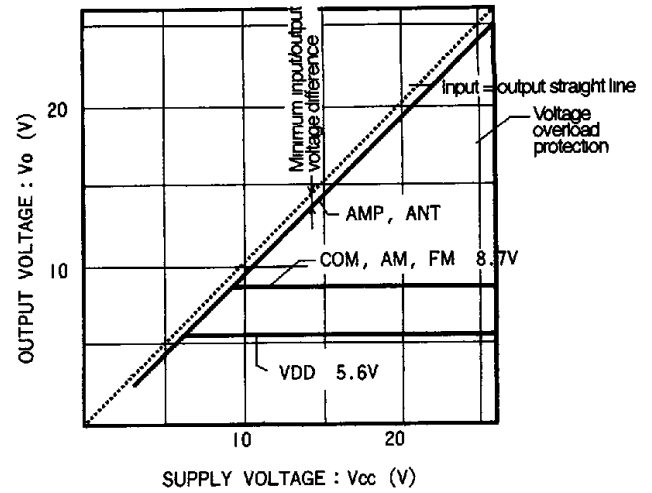

Figure 8

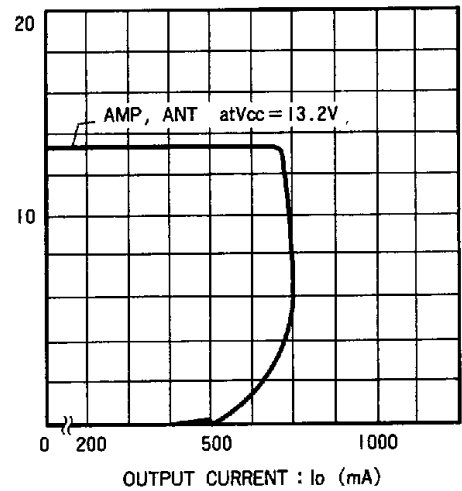

Figure 9

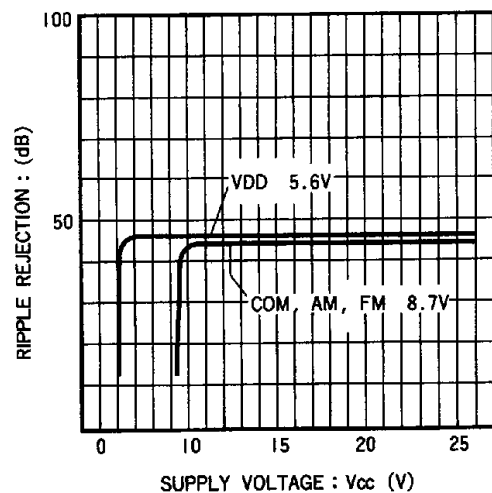

Figure 10