

# Dual recording / playback preamplifier for radio cassette recorders

## BA3420AL

The BA3420AL is dual recording/playback preamplifier for radio cassette players. It has an internal switch for switching between playback head, mic, and radio input modes, and also includes a bias oscillator and regulated voltage source for radio use.

All control is possible with one external switch, allowing designers to reduce the number of external components and the size of their set designs.

### ●Applications

Radio cassette recorders

### ●Features

- 1) Internal three-mode input/output switch for playback head, mic and radio modes.
- 2) Built-in bias oscillator and regulated voltage source for radio use.
- 3) Control of the internal switch and regulated voltage source is possible with one external switch.
- 4) Low distortion.
- 5) Low noise.

### ●Absolute maximum ratings (Ta = 25°C)

Parameter	Symbol	Limits	Unit
Power supply voltage	V <sub>CC</sub>	18	V
Power dissipation	P <sub>d</sub>	400*	mW
Operating temperature	T <sub>opr</sub>	-25~+75	°C
Storage temperature	T <sub>stg</sub>	-55~+125	°C

\* Reduced by 4.0mW for each increase in Ta of 1°C over 25°C.

### ●Recommended operating conditions (Ta = 25°C)

Parameter	Symbol	Min.	Typ.	Max.	Unit
Power supply voltage	V <sub>CC</sub>	5	—	16	V

● Block diagram

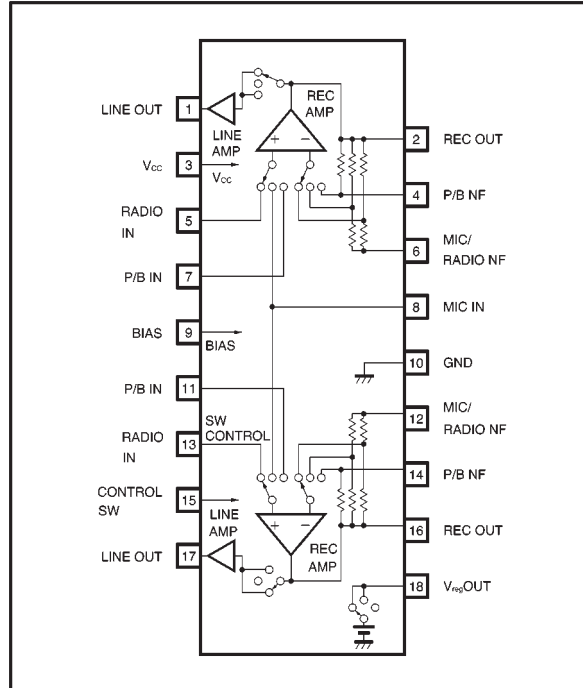

●Electrical characteristics (unless otherwise noted, Ta = 25°C, V<sub>CC</sub> = 8.0V, f = 1kHz and measurement circuit: Fig. 1)

Parameter		Symbol	Min.	Typ.	Max.	Unit	Conditions
Quiescent current		I <sub>o</sub>	—	5.1	9.0	mA	V <sub>IN</sub> =0V <sub>rms</sub> P/B Mode
Voltage gain	P / B Line Amp	G <sub>v</sub> PL	43.0	45.0	47.0	dB	R <sub>L</sub> =10kΩ, V <sub>o</sub> =0dBm
	Mic Rec Amp	G <sub>v</sub> MR	49.5	51.5	53.5	dB	R <sub>L</sub> =2kΩ, V <sub>o</sub> =0dBm
	Radio Rec Amp	G <sub>v</sub> RR	32.0	34.0	36.0	dB	R <sub>L</sub> =2kΩ, V <sub>o</sub> =0dBm
	Radio Line Amp	G <sub>v</sub> RL	17.5	19.5	21.5	dB	R <sub>L</sub> =10kΩ, V <sub>o</sub> =-15dBm
Maximum output voltage	P / B Line Amp	V <sub>o</sub> PL	1.2	1.5	—	V <sub>rms</sub>	THD=1%, R <sub>L</sub> =10kΩ
	Mic Rec Amp	V <sub>o</sub> MR	1.1	1.4	—	V <sub>rms</sub>	THD=1%, R <sub>L</sub> =2kΩ
	Radio Rec Amp	V <sub>o</sub> RR	1.4	1.7	—	V <sub>rms</sub>	THD=1%, R <sub>L</sub> =2kΩ
	Radio Line Amp	V <sub>o</sub> RL	0.25	0.3	—	V <sub>rms</sub>	THD=1%, R <sub>L</sub> =10kΩ
Input conversion noise voltage	P / B Amp	V <sub>NIN</sub> P	—	1.0	2.0	μV <sub>rms</sub>	R <sub>g</sub> =2.2kΩ, V <sub>IN</sub> =0V <sub>rms</sub> , BPF20~20kHz
	Mic Amp	V <sub>NIN</sub> M	—	1.2	2.2	μV <sub>rms</sub>	R <sub>g</sub> =2.2kΩ, V <sub>IN</sub> =0V <sub>rms</sub> , BPF20~20kHz
	Radio Amp	V <sub>NIN</sub> R	—	1.5	3.0	μV <sub>rms</sub>	R <sub>g</sub> =2.2kΩ, V <sub>IN</sub> =0V <sub>rms</sub> , BPF20~20kHz
Total harmonic distortion	P / B Line Amp	THD PL	—	0.05	0.45	%	V <sub>o</sub> =0dBm, R <sub>L</sub> =10kΩ
	Mic Rec Amp	THD MR	—	0.25	1.00	%	V <sub>o</sub> =0dBm, R <sub>L</sub> =2kΩ
	Radio Rec Amp	THD RR	—	0.25	1.00	%	V <sub>o</sub> =0dBm, R <sub>L</sub> =2kΩ
	Radio Line Amp	THD RL	—	0.04	0.45	%	V <sub>o</sub> =-15dBm, R <sub>L</sub> =10kΩ
Interchannel crosstalk level	P/B Line Amp	CT PL	—	—	-50	dBm	P/B <sub>IN</sub> =-45dBm, R <sub>L</sub> =10kΩ
	Radio Rec Amp	CT RR	—	—	-50	dBm	Radio <sub>IN</sub> =-34dBm, R <sub>L</sub> =2kΩ
	Radio Line Amp	CT RL	—	—	-50	dBm	Radio <sub>IN</sub> =-34dBm, R <sub>L</sub> =10kΩ
Inter-mode crosstalk	1	CT 1	—	-62	-49	dBm	P/B <sub>IN</sub> =-45dBm, Mic Mode RecOut
	2	CT 2	—	-110	-80	dBm	P/B <sub>IN</sub> =-45dBm, Mic Mode LineOut
	3	CT 3	—	-72	-59	dBm	P/B <sub>IN</sub> =-45dBm, Radio Mode RecOut
	4	CT 4	—	-92	-79	dBm	P/B <sub>IN</sub> =-45dBm, Radio Mode LineOut
	5	CT 5	—	-72	-59	dBm	Mic <sub>IN</sub> =-51.5dBm, P/B Mode LineOut
	6	CT 6	—	-76	-63	dBm	Mic <sub>IN</sub> =-51.5dBm, Radio Mode RecOut
	7	CT 7	—	-92	-79	dBm	Mic <sub>IN</sub> =-51.5dBm, Radio Mode LineOut
	8	CT 8	—	-72	-59	dBm	Radio <sub>IN</sub> =-34dBm, P/B Mode LineOut
	9	CT 9	—	-62	-48	dBm	Radio <sub>IN</sub> =-34dBm, Mic Mode RecOut
	10	CT 10	—	-107	-80	dBm	Radio <sub>IN</sub> =-34dBm, Mic Mode LineOut
Mic amplifier mute level		Mute	—	—	-80	dBm	Mic <sub>IN</sub> =-51.5dBm, Mic Mode LineOut
Input resistance	P/B Amp	R <sub>IN</sub> P	27	35	43	kΩ	V <sub>IN</sub> =5mV <sub>rms</sub>
	Mic Amp	R <sub>IN</sub> M	14	18	22	kΩ	V <sub>IN</sub> =1.7mV <sub>rms</sub>
	Radio Amp	R <sub>IN</sub> R	27	35	43	kΩ	V <sub>IN</sub> =17mV <sub>rms</sub>
Regulated voltage source output voltage		V <sub>regout</sub>	4.3	4.75	5.2	V	R <sub>L</sub> =50kΩ, Mic Mode
Regulated voltage source output current		I <sub>out</sub>	115	180	—	μA	R <sub>L</sub> =25kΩ, Mic Mode
Regulated voltage source temperature characteristic		ΔV <sub>reg</sub> / ΔT	—	-5.4	—	mV / °C	R <sub>L</sub> =50kΩ, Mic Mode



Item	Symbol	Condition	SW 1	SW 2	SW 3	SW 4	SW 5	SW 6	SW 7	SW 8	SW 9	SW 10	SW 11		
Interchannel crosstalk level	CT PL	P/B LineAmp	1ch→2ch	ON	P	P1	OFF	OFF	OFF	ON	OFF	ON	ON	OFF	
			2ch→1ch	ON	P	P2	OFF	OFF	OFF	OFF	OFF	ON	ON	ON	OFF
	CT RR	Radio RecAmp	1ch→2ch	ON	R	R1	ON	OFF	OFF	OFF	OFF	OFF	ON	ON	OFF
			2ch→1ch	ON	R	R2	OFF	ON	OFF	OFF	OFF	OFF	ON	ON	OFF
	CT RL	Radio LineAmp	1ch→2ch	ON	R	R1	ON	OFF	OFF	OFF	OFF	OFF	ON	ON	OFF
			2ch→1ch	ON	R	R2	OFF	ON	OFF	OFF	OFF	OFF	ON	ON	OFF
Inter-mode crosstalk level	CT 1	P / B→Mic RecOut	ON	M	P1/P2	OFF	OFF	OFF	ON/OFF	OFF/ON	ON	ON	OFF		
	CT 2	P / B→Mic LineOut	ON	M	P1/P2	OFF	OFF	OFF	ON/OFF	OFF/ON	ON	ON	OFF		
	CT 3	P / B→Radio RecOut	ON	R	P1/P2	OFF	OFF	OFF	ON/OFF	OFF/ON	ON	ON	OFF		
	CT 4	P / B→Radio LineOut	ON	R	P1/P2	OFF	OFF	OFF	ON/OFF	OFF/ON	ON	ON	OFF		
	CT 5	Mic→P/B LineOut	ON	P	M	OFF	OFF	ON	OFF	OFF	ON	ON	OFF		
	CT 6	Mic→Radio RecOut	ON	R	M	OFF	OFF	ON	OFF	OFF	ON	ON	OFF		
	CT 7	Mic→Radio LineOut	ON	R	M	OFF	OFF	ON	OFF	OFF	ON	ON	OFF		
	CT 8	Radio→P / B LineOut	ON	P	R1/R2	ON/OFF	OFF/ON	OFF	OFF	OFF	ON	ON	OFF		
	CT 9	Radio→Mic RecOut	ON	M	R1/R2	ON/OFF	OFF/ON	OFF	OFF	OFF	ON	ON	OFF		
	CT10	Radio→Mic LineOut	ON	M	R1/R2	ON/OFF	OFF/ON	OFF	OFF	OFF	ON	ON	OFF		
Mic amplifier mute level	Mute	Mic LineAmp	ON	M	M	OFF	OFF	ON	OFF	OFF	ON	ON	OFF		
Input resistance	R <sub>IN</sub> P	P / B Amp	ON	P	P1/P2	OFF	OFF	OFF	ON/OFF	OFF/ON	OFF	OFF	OFF		
	R <sub>IN</sub> M	Mic Amp	ON	M	M	OFF	OFF	ON	OFF	OFF	OFF	ON	OFF		
	R <sub>IN</sub> R	Radio Amp	ON	R	R1/R2	ON/OFF	OFF/ON	OFF	OFF	OFF	OFF	OFF	OFF		
Regulated voltage source output voltage	V <sub>reg</sub> Out	Mic Mode	ON	M	OFF	OFF	OFF	OFF	OFF	OFF	ON	ON	OFF		
Regulated voltage source output current	I <sub>out</sub>	Mic Mode	ON	M	OFF	OFF	OFF	OFF	OFF	OFF	ON	ON	ON		

●Application example 1

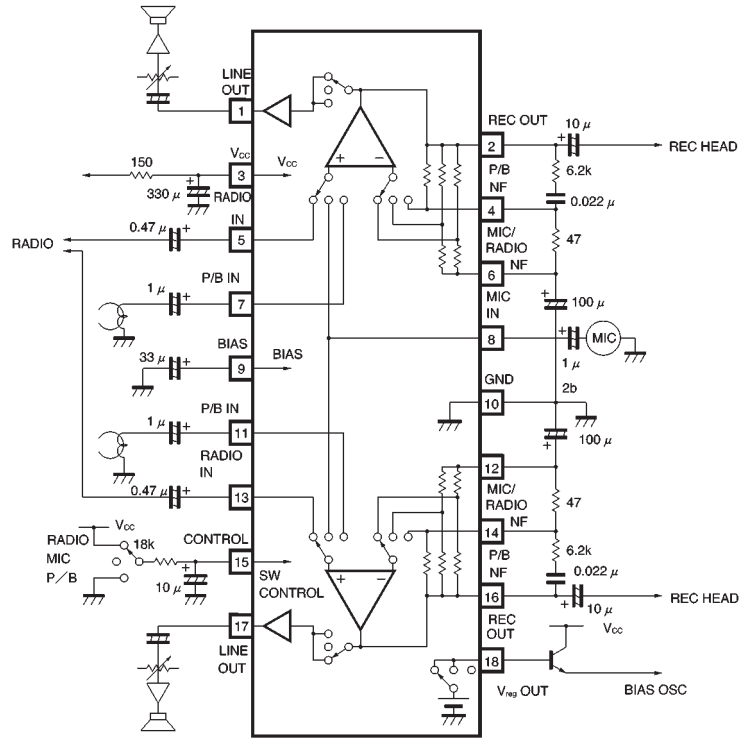

Fig. 2

●Application block diagram

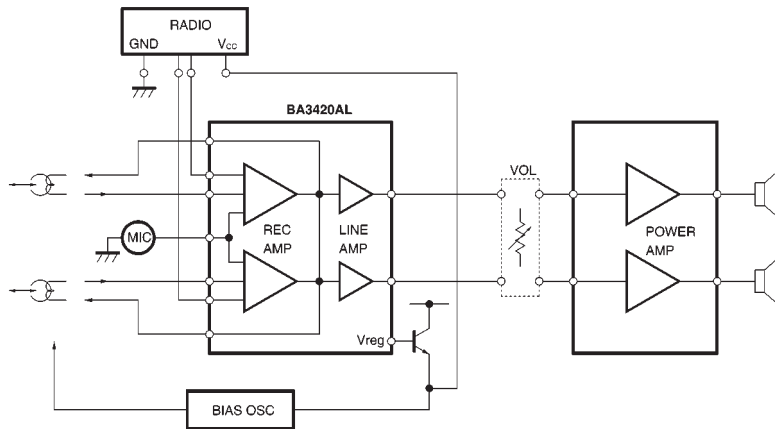
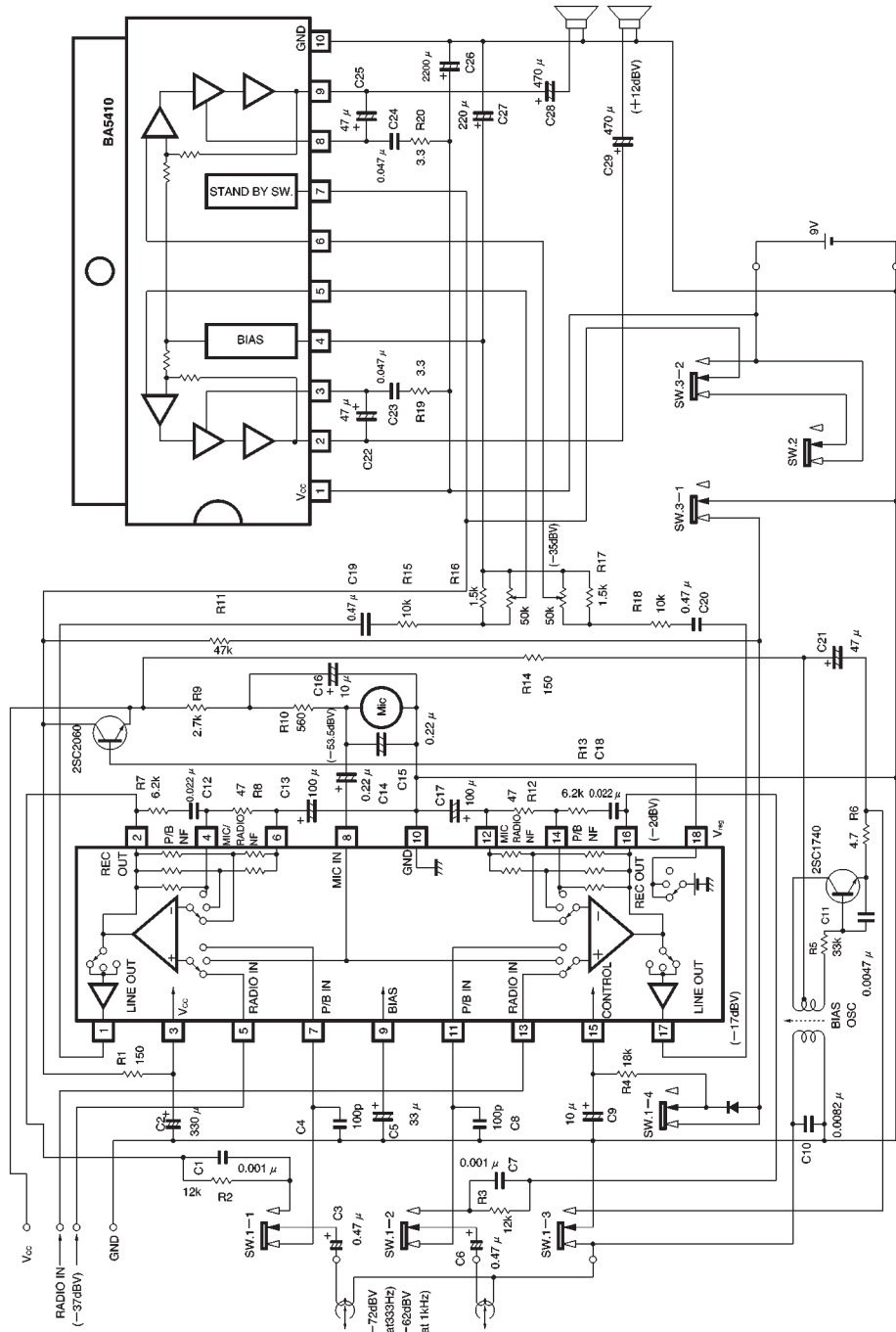

Fig. 3

●Application example 2



Note: The power amplifier used in this circuit example is the BA5410.  
 This component is no longer sold. Use this circuit diagram for reference only.

Fig. 4



●Electrical characteristics curves

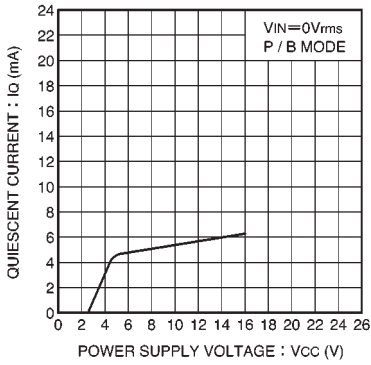

Fig. 5 Quiescent current vs. power supply voltage

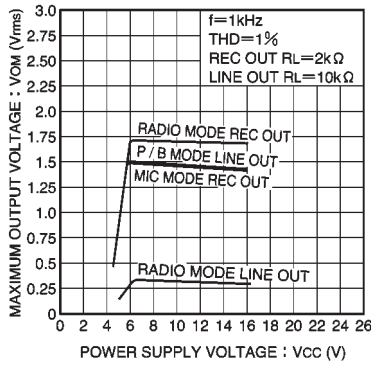

Fig. 6 Maximum output voltage vs. power supply voltage

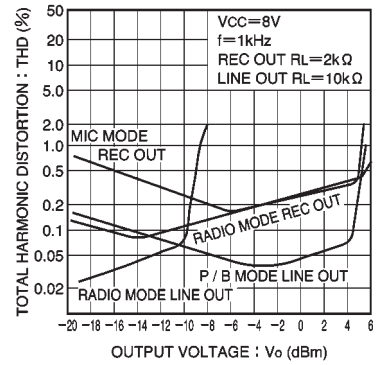

Fig. 7 Total harmonic distortion vs. output voltage

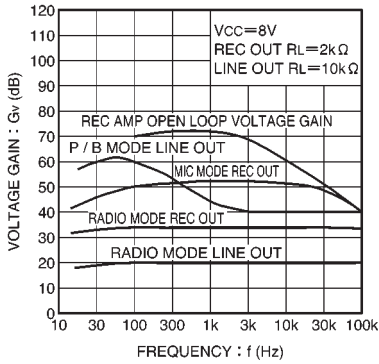

Fig. 8 Voltage gain vs. ambient temperature

●External dimensions (Units: mm)

