

The RF Line
NPN Silicon
RF Power Transistor

... designed for 12.5 volt VHF large-signal power amplifiers in commercial and industrial FM equipment.

- Compact .280 Stud Package
- Specified 12.5 V, 175 MHz Performance
 - Output Power = 15 Watts
 - Power Gain = 12 dB Min
 - Efficiency = 60% Min
- Characterized to 220 MHz
- Load Mismatch Capability at High Line and Overdrive

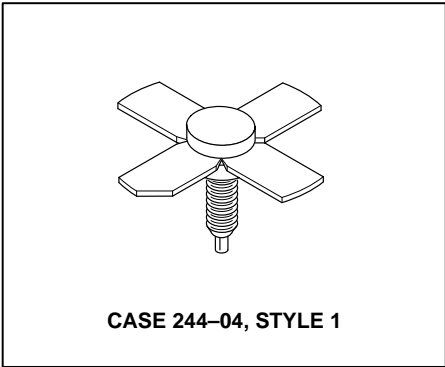
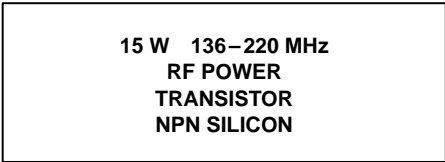

MAXIMUM RATINGS

Rating	Symbol	Value	Unit
Collector-Emitter Voltage	V _{CEO}	18	Vdc
Collector-Base Voltage	V _{CB0}	36	Vdc
Emitter-Base Voltage	V _{EBO}	4.0	Vdc
Collector Current — Continuous	I _C	2.5	Adc
Total Device Dissipation @ T _A = 25°C Derate above 25°C	P _D	40 0.23	Watts W/°C
Storage Temperature Range	T _{stg}	-65 to +150	°C
Junction Temperature	T _J	200	°C

THERMAL CHARACTERISTICS

Characteristic	Symbol	Max	Unit
Thermal Resistance, Junction to Case	R _{θJC}	4.0	°C/W

ELECTRICAL CHARACTERISTICS (T_C = 25°C unless otherwise noted.)

Characteristic	Symbol	Min	Typ	Max	Unit
----------------	--------	-----	-----	-----	------

OFF CHARACTERISTICS

Collector-Emitter Breakdown Voltage (I _C = 25 mA, I _B = 0)	V _{(BR)CEO}	18	—	—	Vdc
Collector-Emitter Breakdown Voltage (I _C = 25 mA, V _{BE} = 0)	V _{(BR)CES}	36	—	—	Vdc
Emitter-Base Breakdown Voltage (I _E = 5.0 mA, I _C = 0)	V _{(BR)EBO}	4.0	—	—	Vdc
Collector Cutoff Current (V _{CB} = 15 Vdc, I _E = 0)	I _{CB0}	—	—	1.0	mA

(continued)

ELECTRICAL CHARACTERISTICS — continued ($T_C = 25^\circ\text{C}$ unless otherwise noted.)

Characteristic	Symbol	Min	Typ	Max	Unit
ON CHARACTERISTICS					
DC Current Gain ($I_C = 500 \text{ mAdc}$, $V_{CE} = 5.0 \text{ Vdc}$)	h_{FE}	10	70	150	—
DYNAMIC CHARACTERISTICS					
Output Capacitance ($V_{CB} = 15 \text{ Vdc}$, $I_E = 0$, $f = 1.0 \text{ MHz}$)	C_{ob}	—	33	60	pF
FUNCTIONAL TESTS (Figure 1)					
Common-Emitter Amplifier Power Gain ($V_{CC} = 12.5 \text{ Vdc}$, $P_{out} = 15 \text{ W}$, $f = 175 \text{ MHz}$)	G_{pe}	12	13	—	dB
Collector Efficiency ($V_{CC} = 12.5 \text{ Vdc}$, $P_{out} = 15 \text{ W}$, $f = 175 \text{ MHz}$)	η	60	68	—	%
Load Mismatch ($V_{CC} = 15.5 \text{ Vdc}$, $P_{in} = 2.0 \text{ dB Overdrive}$, Load VSWR = 30:1)	ψ	No Degradation in Output Power			

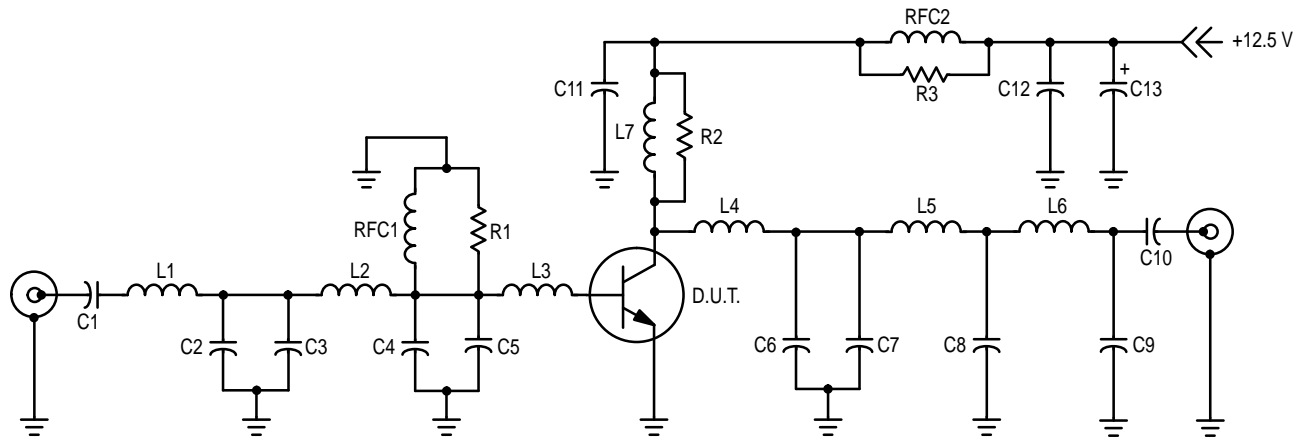

- | | |
|---|---|
| C1, C10, C11 — 1000 pF Ceramic Chip Capacitor | L3 — Copper Pad, 0.200 x 0.400 x 0.060 |
| C2 — 27 pF Mini Unelco Capacitor | L4 — 1/4" #18 AWG into 1/8" High Loop |
| C3 — 33 pF Mini Unelco Capacitor | L5 — 3 Turns #24 AWG Enameled, 3/32" ID |
| C4, C5 — 270 pF Unelco J101 Capacitor | L6 — 6 Turns #24 AWG Enameled, 3/32" ID |
| C6, C9 — 18 pF Mini Unelco Capacitor | L7 — 1-3/4" #16 AWG into 3/4" High Loop |
| C7 — 91 pF Mini Unelco Capacitor | R1 — 12 Ω , 1/2 W Carbon |
| C8 — 68 pF Mini Unelco Capacitor | R2 — 100 Ω , 1.0 W Carbon |
| C12 — 0.1 μF Monolithic Capacitor | R3 — 10 Ω , 1.0 W Carbon |
| C13 — 100 μF , 15 V Electrolytic | RFC1 — 0.15 μH Molded Choke |
| L1 — 3 Turns #18 AWG, 3/16" ID | RFC2 — Ferroxcube Choke, VK200-4B |
| L2 — 1-1/8" #18 AWG into 1/2" High Loop | |

Figure 1. Broadband Circuit

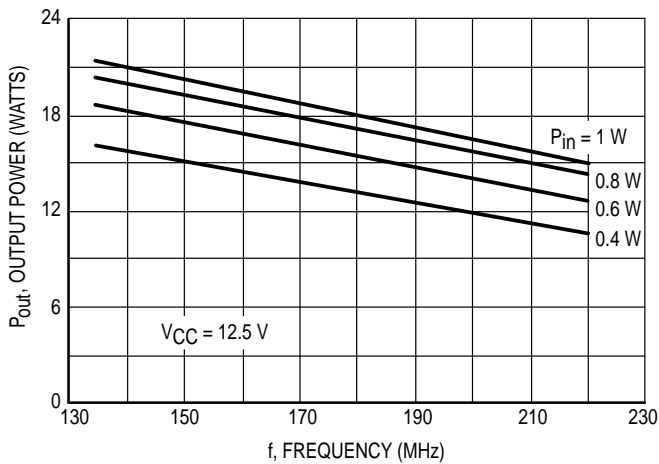

Figure 2. Output Power versus Frequency

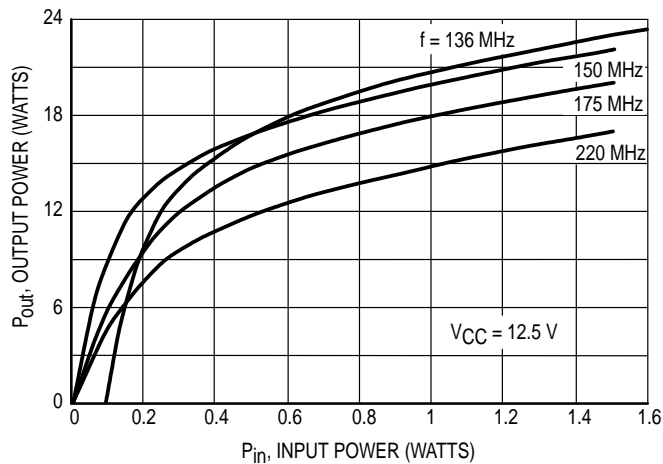

Figure 3. Output Power versus Input Power

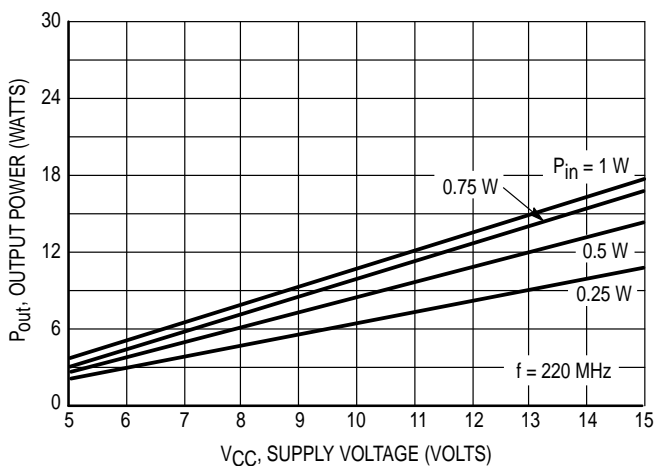

Figure 4. Output Power versus Supply Voltage

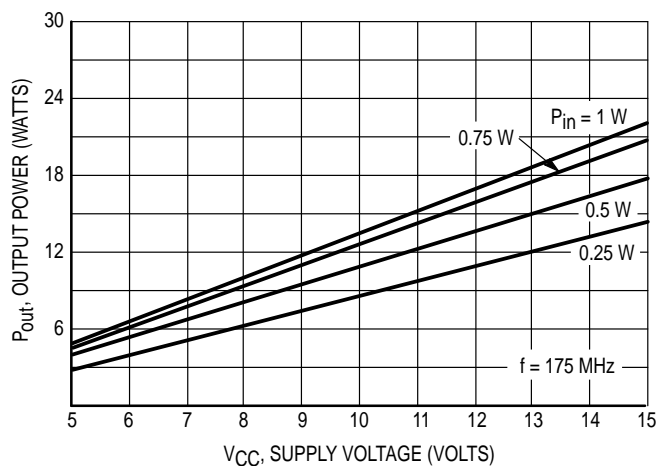

Figure 5. Output Power versus Supply Voltage

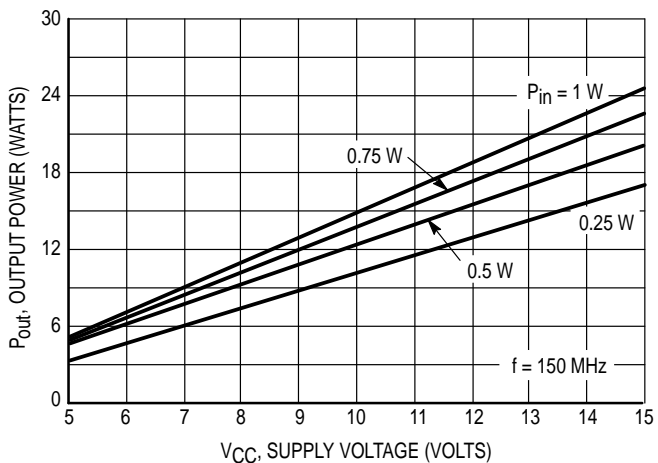

Figure 6. Output Power versus Supply Voltage

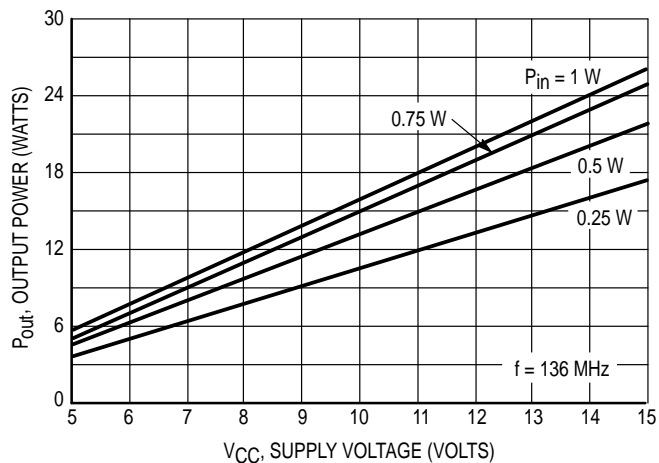

Figure 7. Output Power versus Supply Voltage

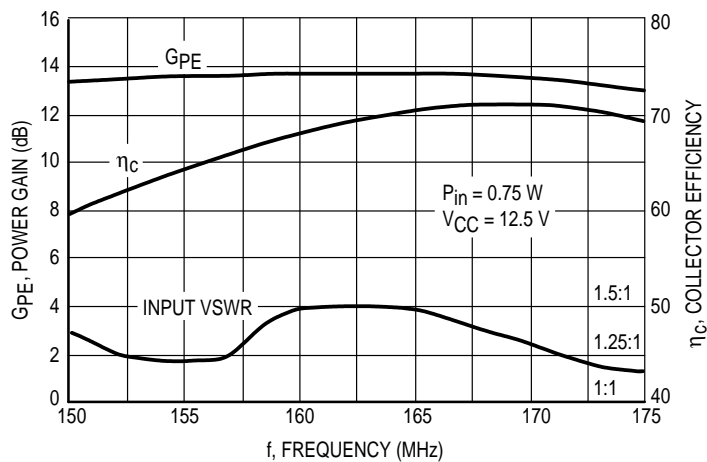
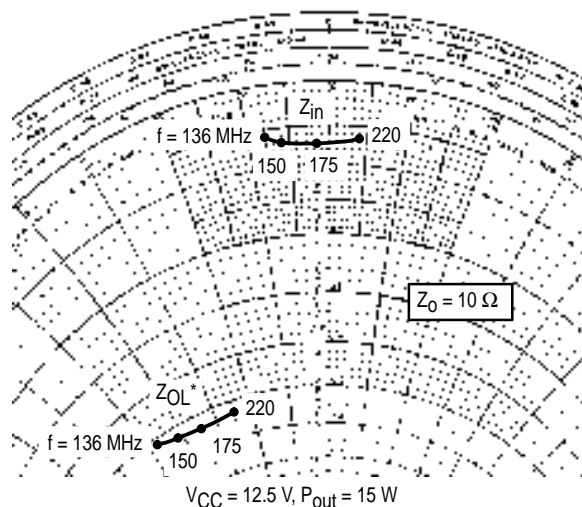

Figure 8. Typical Performance in a Broadband Circuit



f MHz	Z _{in} Ohms	Z _{OL} * Ohms
136	0.59 - j0.80	5.07 - j4.76
150	0.68 - j0.61	5.23 - j4.14
175	0.69 - j0.17	5.26 - j3.46
220	0.62 + j0.39	5.25 - j2.46

Z_{OL}* = Conjugate of the optimum load impedance into which the device output operates at a given output power, voltage and frequency.

Figure 9. Series Equivalent Impedance

PACKAGE DIMENSIONS

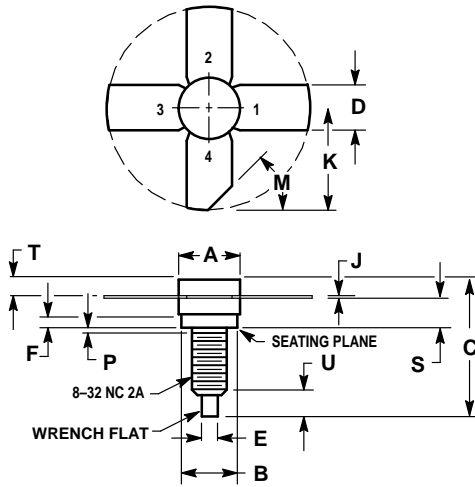

DIM	MILLIMETERS		INCHES	
	MIN	MAX	MIN	MAX
A	7.06	7.26	0.278	0.286
B	6.20	6.50	0.244	0.256
C	14.99	16.51	0.590	0.650
D	5.46	5.96	0.215	0.235
E	1.40	1.65	0.055	0.065
G	1.52	—	0.060	—
J	0.08	0.17	0.003	0.007
K	11.05	—	0.435	—
M	45° NOM		45° NOM	
P	—	1.27	—	0.050
S	3.00	3.25	0.118	0.128
T	1.40	1.77	0.055	0.070
U	2.92	3.68	0.115	0.145

STYLE 1:
 PIN 1. EMITTER
 2. BASE
 3. EMITTER
 4. COLLECTOR

**CASE 244-04
 ISSUE J**

Motorola reserves the right to make changes without further notice to any products herein. Motorola makes no warranty, representation or guarantee regarding the suitability of its products for any particular purpose, nor does Motorola assume any liability arising out of the application or use of any product or circuit, and specifically disclaims any and all liability, including without limitation consequential or incidental damages. "Typical" parameters can and do vary in different applications. All operating parameters, including "Typicals" must be validated for each customer application by customer's technical experts. Motorola does not convey any license under its patent rights nor the rights of others. Motorola products are not designed, intended, or authorized for use as components in systems intended for surgical implant into the body, or other applications intended to support or sustain life, or for any other application in which the failure of the Motorola product could create a situation where personal injury or death may occur. Should Buyer purchase or use Motorola products for any such unintended or unauthorized application, Buyer shall indemnify and hold Motorola and its officers, employees, subsidiaries, affiliates, and distributors harmless against all claims, costs, damages, and expenses, and reasonable attorney fees arising out of, directly or indirectly, any claim of personal injury or death associated with such unintended or unauthorized use, even if such claim alleges that Motorola was negligent regarding the design or manufacture of the part. Motorola and  are registered trademarks of Motorola, Inc. Motorola, Inc. is an Equal Opportunity/Affirmative Action Employer.

Literature Distribution Centers:

USA: Motorola Literature Distribution; P.O. Box 20912; Phoenix, Arizona 85036.

EUROPE: Motorola Ltd.; European Literature Centre; 88 Tanners Drive, Blakelands, Milton Keynes, MK14 5BP, England.

JAPAN: Nippon Motorola Ltd.; 4-32-1, Nishi-Gotanda, Shinagawa-ku, Tokyo 141, Japan.

ASIA PACIFIC: Motorola Semiconductors H.K. Ltd.; Silicon Harbour Center, No. 2 Dai King Street, Tai Po Industrial Estate, Tai Po, N.T., Hong Kong.



MRF2628/D

