

Features

- ST-BUS/GCI compatible switch matrix
- 64 channel non-blocking time switch
- 2 x 32 channel serial inputs and outputs
- Per-channel tristate control
- 4-pin serial microprocessor interface
- Patented message mode
- Low power consumption (10 mW)
- Single 5 volt supply

Applications

- Cost sensitive digital switching applications
- Digital key telephone systems
- GCI/ST-BUS conversion
- ST-BUS device control interface
- ISDN telephone set support circuit
- Interprocessor communication

ISSUE 6

May 1995

Ordering Information

MT8982AE	16 Pin Plastic DIP
MT8982AS	16 Pin SOIC
MT8982AN	20 Pin SSOP
-40 to +85°C	

Description

The MT8982 Small Digital Switch (MiniDX) is a non-blocking CMOS time switch with a capacity of up to 64 - 8 bit Time Division Multiplexed (TDM) encoded voice or data channels. It is a size-optimized version of MITEL's successful MT8980D Digital Switches, providing switching capability in cost sensitive applications such as telephone sets and digital key systems. The TDM interface to the device is via two pairs of 2048 kbit/s serial streams with 32 64 kbit/s channels per stream (ST-BUS). A serial microport provides access to the device for programming the required connections. The serial microport is compatible with most common microcontrollers. The unique message mode capability allows the MT8982 to act as a controller for other members of MITEL's ST-BUS family of components.

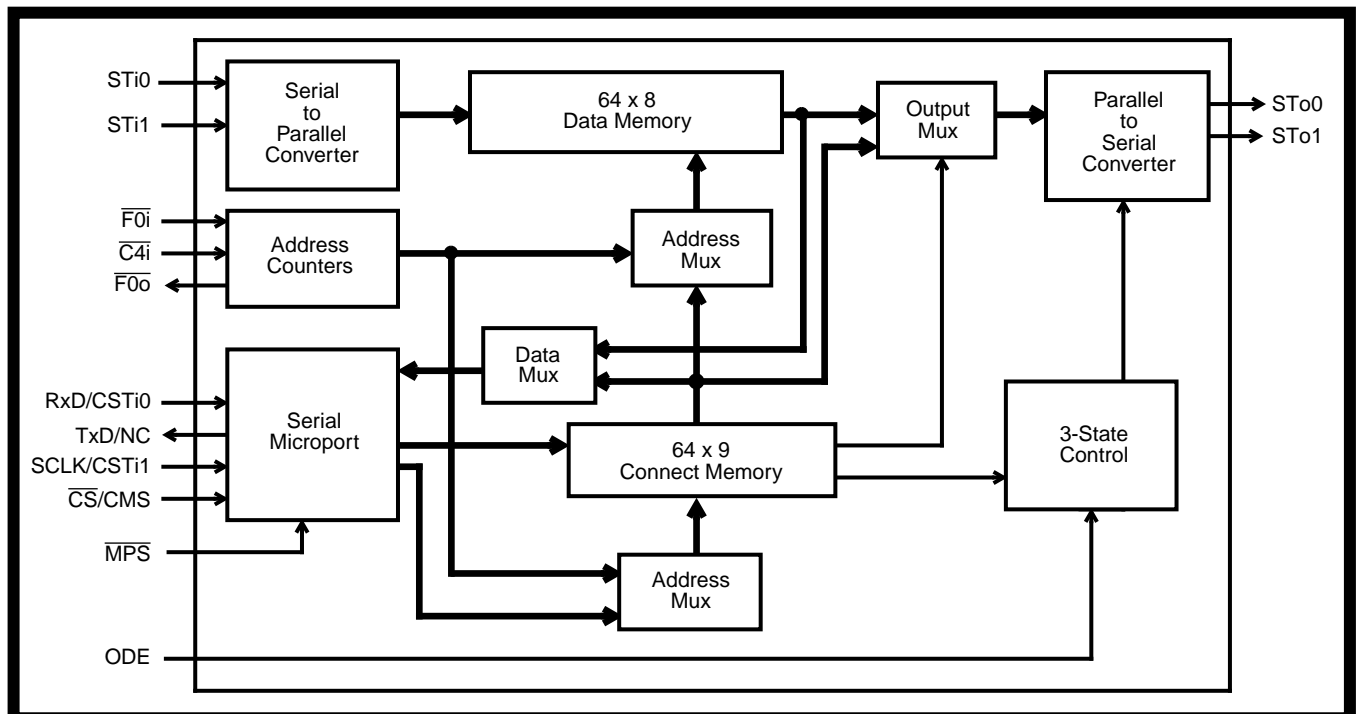

Figure 1 - Functional Block Diagram

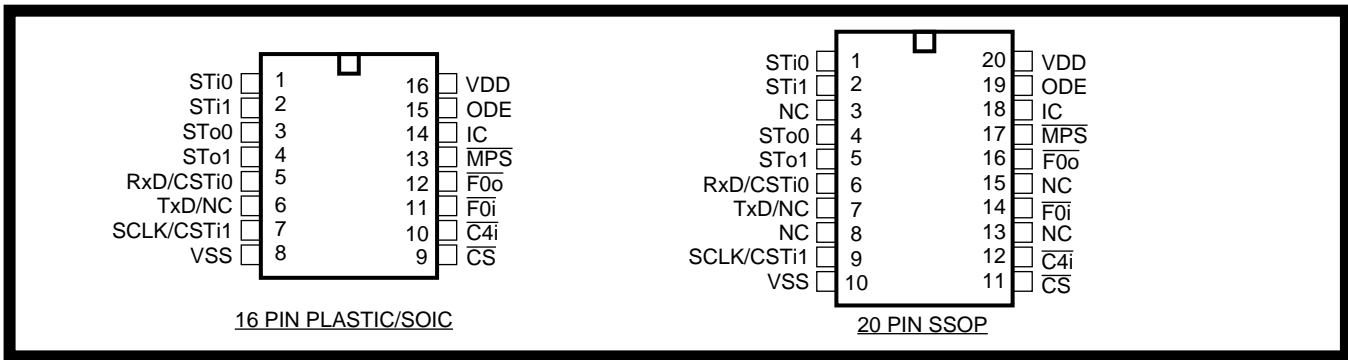

Figure 2 - Pin Connections

Pin Description

Pin #		Name	Description
16	20		
1-2	1-2	STi0- STi1	Serial TDM Input 0 and 1 (Inputs). 2048 kbit/s input data streams containing 32 8-bit channels synchronized to F0i.
3-4	4-5	STo0- STo1	Serial TDM Output 0 and 1 (Outputs). 2048 kbit/s output data streams containing 32 8-bit channels synchronized to F0i.
5	6	RxD/ CSTi0	Received Data/Control Stream Input 0 (Input). When \overline{MPS} is low, this pin receives serial microport data clocked in by the rising edge SCLK. When \overline{MPS} is high, this pin receives a 2048 kbit/s serial TDM stream containing 32 8-bit channels, which are written into the Connect Memory locations corresponding to STo0.
6	7	TxD	Transmit Data (Output). When \overline{MPS} is low, serial microport data is clocked out on this pin by the falling edge of SCLK. When \overline{MPS} is high this output is disabled.
7	9	SCLK/ CSTi1	Serial Microport Clock/Control Stream Input 1 (Input). When \overline{MPS} is low, this pin receives a clock which is used to clock data to/from a microcontroller via a serial microport. When \overline{MPS} is high, this pin receives a 2048 kbit/s serial TDM stream containing 32 8-bit channels, which are written into the Connect Memory locations corresponding to STo1.
8	10	V _{SS}	Power Input. Negative supply (ground).
9	11	\overline{CS}	Chip Select (Input). When \overline{MPS} is low, a low on this pin enables the serial microport. A high on this pin disables RxD and tristates TxD. When \overline{MPS} is high, this pin must be low.
10	12	$\overline{C4i}$	Serial TDM Clock (Input). This clock input is used to clock the TDM data into and out of the device and refreshes the internal dynamic RAM. The clock rate is 4.096 MHz and data is clocked in on the rising edge of $\overline{C4i}$ three-quarters of the way through a bit period.
11	14	$\overline{F0i}$	Frame Pulse (Input). This input is the frame synchronization pulse for the 2048 kbit/s serial TDM streams. It may be either active low straddling the frame boundary (ST-BUS) or active high at the beginning of timeslot 5 (GCI).
12	16	F0o	Frame Pulse (Output). This pin outputs a frame pulse in the opposite format to F0i (GCI or ST-BUS) delayed or advanced by five channels.
13	17	\overline{MPS}	Microport Select (Input). When this pin is held low, the serial microport is in normal mode. When this pin is high, the microport is in serial bus mode.
14	18	IC	Internal Connection. Tie to V _{SS} for normal operation.
15	19	ODE	Output Drive Enable (Input). When this pin is held high, the STo0 and STo1 output drivers function normally. When this pin is low, STo0 and STo1 are tristated. NB: When ODE is high, individual channels on STo0 and STo1 can be tristated under software control.
16	20	V _{DD}	Power Input. Positive supply.
	3,8, 13,15	NC	No Connection.

Functional Description

The MT8982 (MiniDX) provides cost effective time switching capability for small size applications utilizing up to two serial Time Division Multiplexed (TDM) streams. Each TDM stream consists of 32 64 kb/s channels, giving the MiniDX a maximum capacity of 64 channels. The input framing signal may be either a ST-BUS or a GCI frame pulse. The MT8982 will output a delayed or advanced frame pulse in the opposite format to permit conversion between the two formats.

The MiniDX can switch data from any channel in one of the two serial input TDM streams to any channel in either of the two serial output TDM streams. The microcontroller controlling the MiniDX writes to the MT8982 Connect Memory to establish the connection between the required input TDM channel and the selected output TDM channel(s). By reading the Connect Memory the microcontroller can check switched connections which have already been established.

The MiniDX can also operate in message mode where the microcontroller transmits the data on the TDM serial stream. The microcontroller writes to the MT8982 Connect Memory to transmit data on the required output TDM channels. Reading the Data Memory of the MT8982 allows the microcontroller to receive messages from TDM input channels. These operations are useful for control of other ST-BUS components or for interprocessor communication.

Hardware Description

TDM Interface

The MT8982 continuously receives TDM serial data at 2048 kbit/s through two serial inputs. These serial streams are then converted into a parallel format and stored sequentially in a 64x8 bit Data Memory. The sequential addressing is generated by an internal counter that is reset by the input 8 kHz frame pulse ($\overline{F0i}$) which marks the frame boundaries of the incoming serial data stream. This counter increments with each timeslot so that it matches the binary count of the timeslot of the incoming data. The TDM timeslot count always corresponds to the ST-BUS channel positions. An extra address bit is used to differentiate between the two input data streams.

The input 8 kHz frame pulse may be either ST-BUS or GCI formatted. A ST-BUS formatted frame pulse is an active low signal which straddles the frame boundary. It idles high the rest of the time. A GCI

formatted frame pulse is active high at the beginning of timeslot 5 (relative to the MT8982) and idles low. The MT8982 automatically determines the type of frame pulse from the level of the idle over five clock periods. A ST-BUS formatted frame pulse resets the internal address counters to zero. A GCI formatted frame pulse resets the counters to five.

$\overline{F0o}$ outputs a frame pulse in the opposite format. If $\overline{F0i}$ is a ST-BUS formatted frame pulse, $\overline{F0o}$ will be a GCI formatted frame pulse delayed by five channels after $F0i$. If $\overline{F0i}$ is a GCI formatted frame pulse, $\overline{F0o}$ will be a ST-BUS formatted frame pulse delayed by 27 channels (32-5).

During normal operation every second falling edge of the clock marks a timeslot boundary and the input data is clocked in by the rising edge, three-quarters of the way into the bit cell. The master clock must be 4.096 MHz for the $\overline{F0o}$ signal to be valid and to receive a GCI formatted $\overline{F0i}$.

Data which is output onto a TDM serial output channel may come from two sources; the Data Memory or the Connect Memory. If a channel is configured in connection mode, the source of output data is the Data Memory. If a channel is configured in message mode, the source of the output data is the Connect Memory. Data destined for a particular channel on the serial output links is read from the data or connect memory in the previous channel timeslot. This allows for delay in RAM access and parallel-to-serial conversion. Each output data channel can also be placed in tristate mode.

When an output channel is in connection mode, the TDM output data is read from a Data Memory location pointed to by an address stored in the 64x8 bit Connect Memory. The Connect Memory locations are addressed sequentially, with each location corresponding to an output TDM link/channel. In the channel time before the data is to be output, the contents of each Connect Memory location are output to the address bus of the Data Memory. The contents of the Data Memory at the selected address are then transferred to the parallel-to-serial converter. The parallel-to-serial converter outputs onto the TDM serial stream during the correct channel time. By having the output channel specify the input channel, the user can route the same input channel to several output channels. This function is useful for broadcasting or resource channel uses.

When an output channel is in message mode, the data for the output channel originates from the microcontroller. The microcontroller writes data to the Connect Memory location which corresponds to the output link and channel number. The contents of the Connect Memory are transferred directly to the serial-to-parallel converter one channel time before it is to be output. The Connect Memory data is output MSB first, repetitively once per frame, until it is changed by the microcontroller.

If the output channel is configured in tristate mode, the TDM serial stream output will be placed in high impedance during that channel time. This mode is entered by configuring the channel into connection mode and then setting the tristate control bit. All channels on both output TDM streams can be tristated by pulling pin 16 (ODE) low. This overrides the individual channel programming.

The Data and Connect Memories are dynamic memories. They are refreshed by the sequential addressing generated by $\overline{C4i}$.

Microcontroller Interface

The MT8982 is controlled via a synchronous, serial microport. The microport is compatible with Intel's MCS-51 serial port Mode 0 specifications, Motorola's Serial Peripheral Interface (SPI) specifications, and National's MicroWire specifications. The port consists of a transmit data line (TxD), a receive data line (RxD), a chip select line (\overline{CS}), and a synchronous clock input (SCLK). All memory locations and control functions on the MiniDX are accessed through this port. The microport may also be configured in serial bus mode where data is clocked into the Connect Memory in the same way as STi0 and STi1 are clocked into Data Memory.

In serial microport mode, \overline{CS} must be low to enable a microport access. SCLK clocks the serial microport data in or out through RxD and TxD, LSB first. The TxD output driver is tristated when it is inactive. This allows RxD and TxD to be connected together for a single TxD/RxD line as used in the INTEL MCS-51 microcontrollers. Figure 3 shows a serial microport access cycle.

A microport access cycle (microcycle) begins with a falling edge on \overline{CS} . Eight bits of data are clocked into RxD by the rising edge of SCLK. Two of these eight bits indicate whether the microcycle operation is a read or a write, the rest of the bits are used for addressing. These eight bits are defined as the command/ address byte (Table 1). If the microcycle operation is a write, another eight bits are clocked

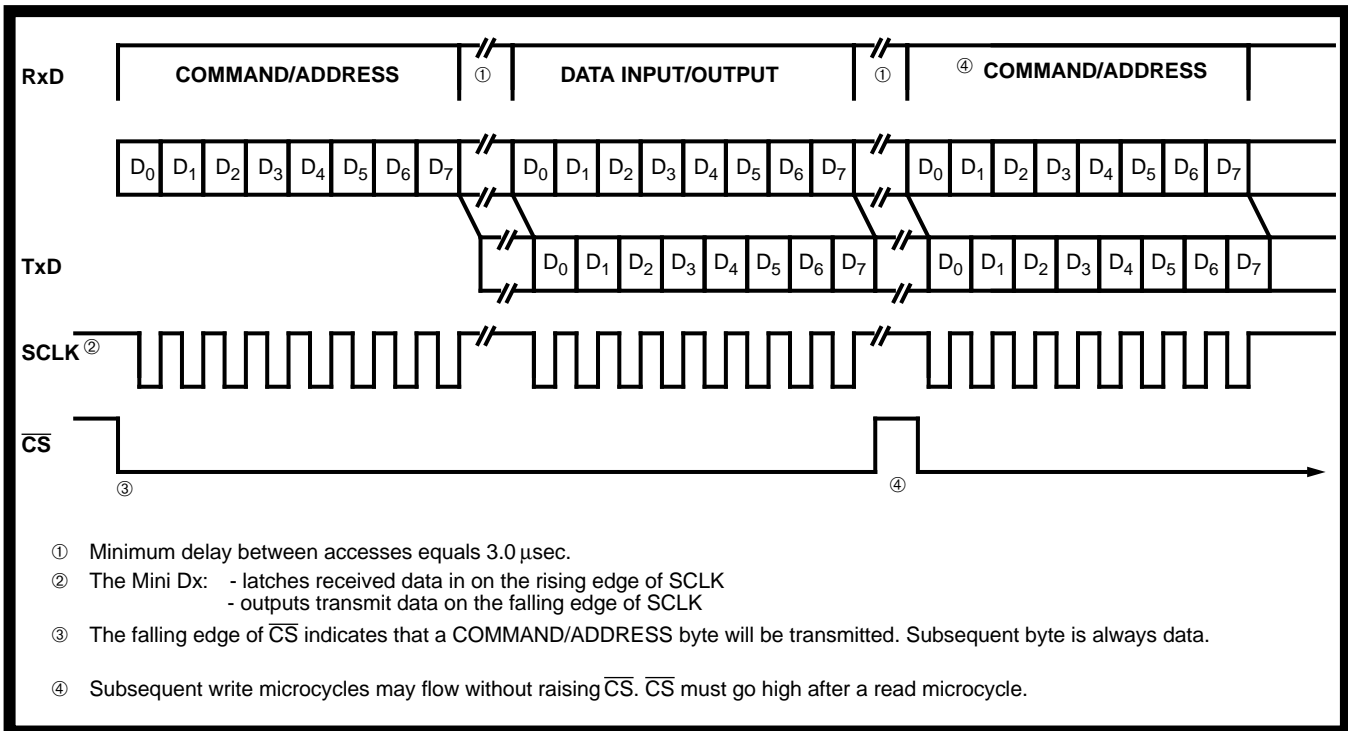

Figure 3 - Serial Microport Timing

into RxD by the rising edges of the next eight SCLK cycles. If the operation is a read, eight data bits are clocked from TxD by the falling edges of the next eight SCLK cycles. The rising edge of \overline{CS} tristates TxD after the last transmitted bit.

Successive write microcycles can take place while \overline{CS} remains low, with each microcycle following the sequence of a command/address byte followed by a data byte. \overline{CS} must go high after a read microcycle. Note that a command/address byte must always follow the high to low transition on \overline{CS} .

When the \overline{MPS} input is pulled high and the \overline{CS} input is pulled low, the microport is put into serial bus mode. Pins RxD and SCLK become CSTi0 and CSTi1, respectively, and are configured as 2048 kbit/s serial streams with 32 channels each. The frame and timeslot boundaries are determined by $\overline{F0i}$ and $\overline{C4}$. Each channel on CSTi0 and CSTi1 is stored in the connect memory address corresponding to the link and channel number. The Data Memory and the Connect Memory cannot be read when the microport is in serial bus mode.

Device Timing

During each TDM timeslot, eight read or write operations occur internally in the MT8982. These are shown in Figure 4. During the first two bit periods, data received in the previous timeslot on the two input TDM streams is loaded into the Data Memory. Bit periods 2 and 6 are serial microport access windows; data may be read from, or written to any accessible memory location. During bit periods 3 and 5, data is read from the connect memory for the next timeslot on links 0 and 1 respectively. The Data Memory locations which are addressed by the previous reads of the connect memory are accessed during bit periods 4 and 7.

When the microport is in serial bus mode, bit periods 2 and 6 have a slightly different function. Data from the previous timeslot of CSTi0 and CSTi1 respectively is written to the corresponding connect memory locations.

The transfer of information from the input TDM streams to the output TDM streams results in a delay through the MT8982. This delay is dependent only on the combination of source and destination

Bit	Name	Description								
7	Stream	Stream. This is the most significant bit of the address for the memory location that is to be accessed. It corresponds to one of the TDM serial streams (0-1).								
2-6	Ch0-Ch4	Channel 0-4. These bits are the five least significant bits of the address for the memory location that is to be accessed. The binary value of these bits correspond to a TDM channel (0-31).								
0-1	Cmd0-Cmd1	<p>Command Select 0-1. These two bits define the four command operations for the MT8982. The destination addressed by the command is defined in bits 2-7 of the Command/Address byte.</p> <p>Cmd0-Cmd1</p> <table border="0"> <tr> <td>0-0</td> <td>Read from Connect Memory.</td> </tr> <tr> <td>0-1</td> <td>Write to Connect Memory and set connection mode.</td> </tr> <tr> <td>1-0</td> <td>Read Data Memory.</td> </tr> <tr> <td>1-1</td> <td>Write to Connect Memory and set message mode.</td> </tr> </table>	0-0	Read from Connect Memory.	0-1	Write to Connect Memory and set connection mode.	1-0	Read Data Memory.	1-1	Write to Connect Memory and set message mode.
0-0	Read from Connect Memory.									
0-1	Write to Connect Memory and set connection mode.									
1-0	Read Data Memory.									
1-1	Write to Connect Memory and set message mode.									

Table 1. Command Address Byte

Bit	Name	Description
7	NA	Unused.
6	ODE	Output Drive Enable. When this bit is set, the addressed TDM channel is placed in tristate. When low, the output is enabled.
5	STi	Input Stream. This bit defines the input TDM stream from which the output data is sourced (0-1).
0-4	SC0-SC4	Source Channel 0-4. The binary value of these bits defines the input channel from which the output data is sourced (0-31).

Table 2. Connect Memory Connection Mode Data Byte

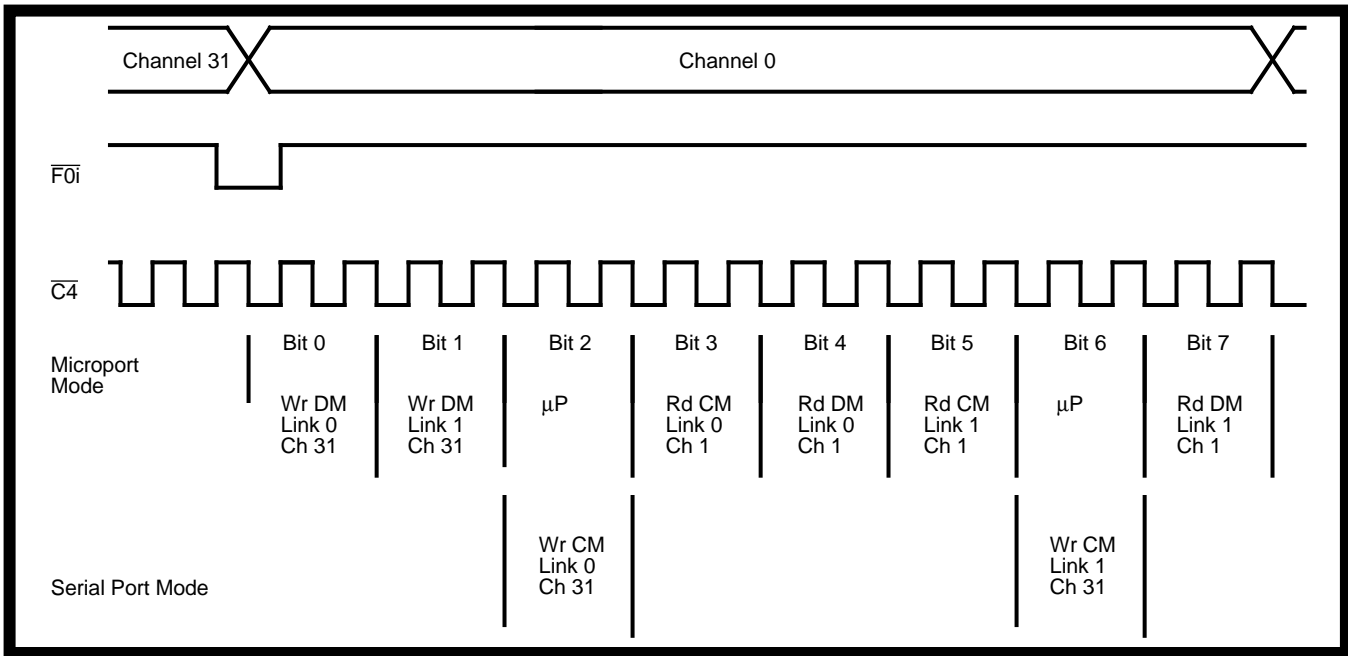

Figure 4 - Internal Memory Access Windows

channels and is not dependent on the input and output streams. The delays are given in Table 3. The maximum delay is one frame plus one channel; the minimum delay is two channels.

Input Channel	Output Channel	Delay
n	m = n, n+1	m- n + 32 channels
n	m > n+1	m- n channels
n	m < n	32- (n-m) channels

Table 3. Input Channel to Output Channel Delay Times

The following delays apply to writing data to the Connect Memory in message mode. For stream 0, data must be written to a Connect Memory location at least one timeslot before the corresponding output channel or the output data will be delayed by one frame. For stream 1, data must be written at least two timeslots before the output channel or the output data will be delayed by one frame.

Device Programming

Microport Mode

In serial microport mode, the MT8982 is programmed and read using microcycles which consist of a command/address byte followed by a data byte.

The Command/Address Byte is shown in Table 1. Bits 0 and 1 are the command bits (Cmd0-1), and are used to indicate the type of microcycle access. The microcontroller can read the Data Memory, read or write the Connect Memory, and set per-channel message or connection mode. Bits 2 to 6 of the command/address byte (Ch0-Ch4) correlate to a channel on a TDM stream (0-31). Bit 7 (STREAM) correlates to stream 0 or stream 1. These bits address the corresponding Data Memory or Connect Memory location.

The microcycle operations selected by the command/address byte are as follows:

Read Connect Memory (Cmd0-1: 0,0)

Bits 0 to 7 of the addressed Connect Memory location will be transmitted to the microcontroller in the following data byte. Depending on what the last Connect Memory write mode was, the data transmitted could be a message byte or a Connection Mode data byte.

Write Connect Memory - Set Connection Mode
(Cmd0-1: 0,1)

The corresponding output channel to the addressed Connect Memory location is configured in connection mode. The Connection Mode Data Byte (Table 2) will be received by the MT8982 in the following data byte. Bits 0 to 4 (SC0-SC4) select the source input channel for switching to this output channel. Bit 5 (STi) selects the input stream. Bit 6 (ODE) enables/disables tristate for this channel. Bit 7 is unused in connection mode.

Read Data Memory (Cmd0-1: 1,0)

The contents of the addressed Data Memory location are transmitted to the microcontroller in the following data byte.

Write Connect Memory - Set Message Mode
(Cmd0-1: 1,1)

The corresponding output channel to the addressed Connect Memory location is configured in message mode. The following data byte will be received by the MT8982 and written to the address Connect Memory location. The data byte will be output directly to the corresponding output channel.

The following example shows a typical programming sequence for the MT8982. A connection is to be made from stream 1 channel 6 to stream 0 channel 15:

- The microcontroller pulls \overline{CS} low.
- The microcontroller transmits eight clock pulses to SCLK and a Command/Address byte, HEX 3E, to RxD. The Command/Address byte addresses output channel 15, stream 0, configures that channel as connection mode and identifies the microcycle as a write to the Connect Memory.
- The microcontroller transmits another eight clock pulses to SCLK and sends the Connection Mode Data Byte, HEX 26, to RxD. The Connection Mode Data Byte addresses input channel 6, stream 1 in the Data Memory. Note that at least two microseconds must occur between the two accesses.

The connection is now complete. The microcontroller may now check that the connection is correct:

- The microcontroller transmits eight clock pulses to SCLK and a Command/Address byte, HEX 3C, to RxD. The Command/Address byte addresses output channel 15, stream 0 and identifies the microcycle as a read from the Connect Memory.
- The microcontroller transmits another eight clock pulses to SCLK. The MT8982 outputs the Connect Memory data, HEX 26, on TxD. At least two microseconds must occur between the two accesses to ensure that the MiniDX can clock out the data.
- \overline{CS} goes high to terminate the session.

This connection is only in one direction. To make a bidirectional connection the MT8982 must also be programmed to connect stream 0 channel 15 to stream 1 channel 6.

Serial Bus Mode

When the microport is in serial bus mode the MT8982 is programmed via the two ST-BUS serial streams CSTi0 and CSTi1. Each channel in these two streams is written directly into the corresponding address in the Connect Memory. The data written to the Connect Memory is always the Connection Mode Data Byte as described in Table 2. To set up a connection, the Connection Mode Data Byte is transmitted to the MT8982 on the CSTi stream and channel number which is the same as the desired STo stream and channel number. As long as the device remains in serial bus mode, the Connection Mode Data byte must be transmitted continuously, every frame, to maintain the connection.

Message mode is not available when the device is in serial bus mode. Also, neither the Connect Memory nor the Data Memory can be read while the device is in serial bus mode. MITEL's MT8980, MT9080 and MT8920 devices can all be used as programmable parallel-to-ST-BUS serial interfaces for CSTi0 and CSTi1.

Initialization

On power up the contents of the Connect Memory can be in any state. In order to prevent false programming of peripheral ST-BUS devices or false data transmission, ODE should be kept low during power up. This will keep the two TDM outputs in high impedance until the MT8982 Connect Memory is programmed.

Applications

Digital Key Telephone System

Figure 5 shows a block diagram of a Digital Key Telephone System (DKTS) implemented with the MT8982. This DKTS can support up to 64 connections organized in any combination of subscriber lines or trunks. A very small system consisting of six lines and one trunk can very easily and economically be designed on one board. The MT8982 significantly reduces the tracking and board space required for competitive switch matrices.

Distributed Switching System

The MT8982 can be used to distribute switching capability in a very large system. In Figure 6 the MT8982 is shown with the microport in serial bus mode. This allows the central microprocessor to set up and tear down connections at the remote locations by programming the remote MT8982's through their CSTi pins. A microcontroller in each remote switch would not be required.

Primary Rate Serial Controller

Figure 7 shows the MT8982 used in a primary rate serial control application. The MT8982 is used as the control interface from a microcontroller to MITEL's MH89760/790 T1 Primary Rate Interfaces using the microcontroller's serial microport. The MT8982 offloads signalling and trunk control functions from the central switch matrix leaving more capacity for switching.

ST-BUS to GCI Conversion

The MT8982 MiniDX may be used to provide a gateway between MITEL's ST-BUS family of components and an architecture which utilizes the General Circuit Interface (GCI) operating at 2048 kbit/s (Figure 8). The MT8982 performs automatic adaptation of the different frame pulse signals. The master frame pulse to the MT8982 can be supplied either by the ST-BUS or the GCI components. The MT8982 will then provide either a delayed or advanced frame pulse to the other components as shown in Figures 9 and 10.

When an ST-BUS component is supplying the master frame pulse ($\overline{F0i}$), the MiniDX will supply the output frame pulse ($\overline{F0o}$) delayed by five channels. This ensures that frame integrity is maintained between the ST-BUS and GCI components. When a GCI component supplies the master frame pulse ($\overline{F0i}$), $\overline{F0o}$ is advanced by five channels.

Figure 8 shows a block diagram of a GCI to ST-BUS conversion circuit. External inversion of the clock signal is required between the ST-BUS and GCI components because the ST-BUS and GCI master C4 clocks use different edges to mark bit boundaries.

To program a connection between a ST-BUS channel and a GCI channel, some channel conversion is necessary. Figure 11 shows the relationship between the ST-BUS basic access frame and the GCI basic access frame. Because the MT8982 shifts the GCI frame pulse (input or output) by five channels, all of the GCI channels must be incremented by five to be correctly addressed by the

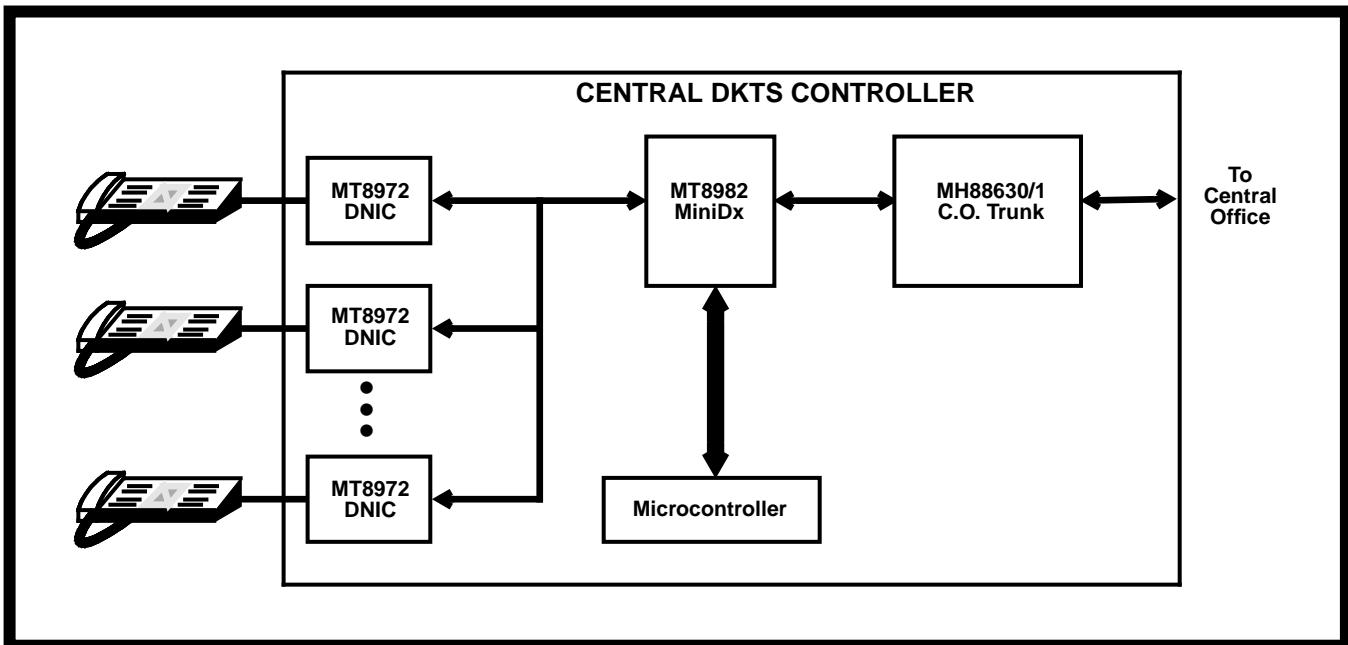

Figure 5 - Digital Key Telephone System (DKTS)

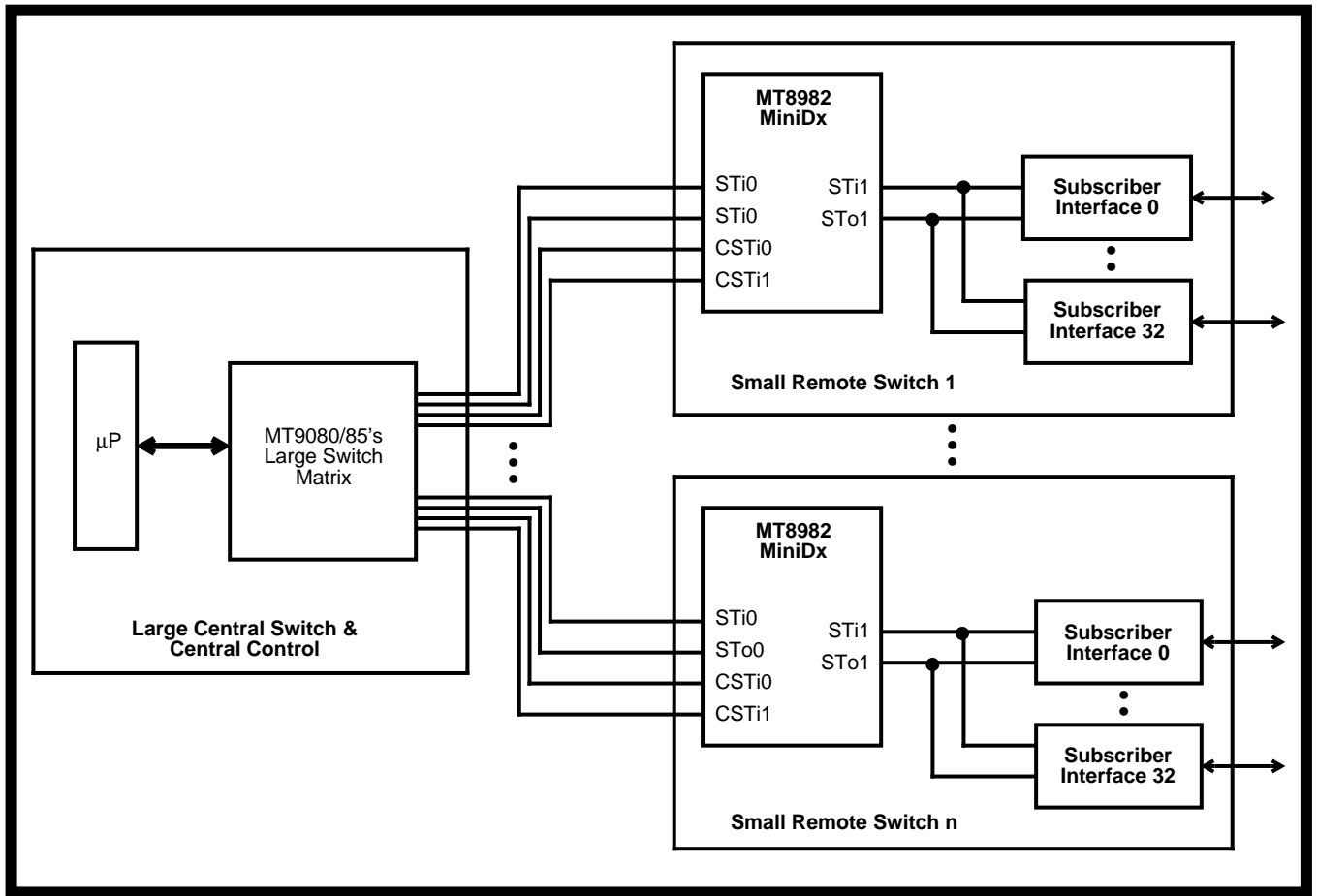

Figure 6 - Distributed Switching System

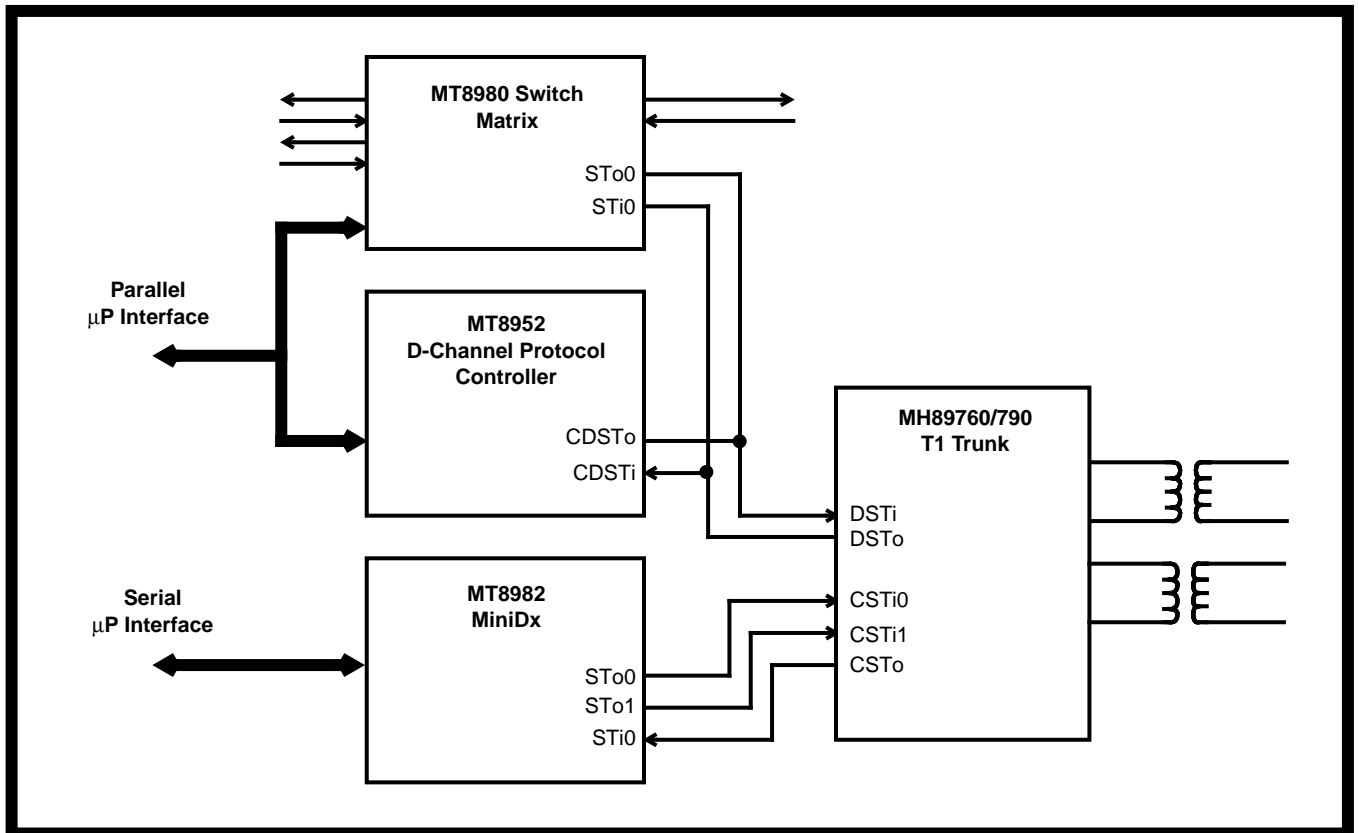

Figure 7 - Primary Rate Serial Controller

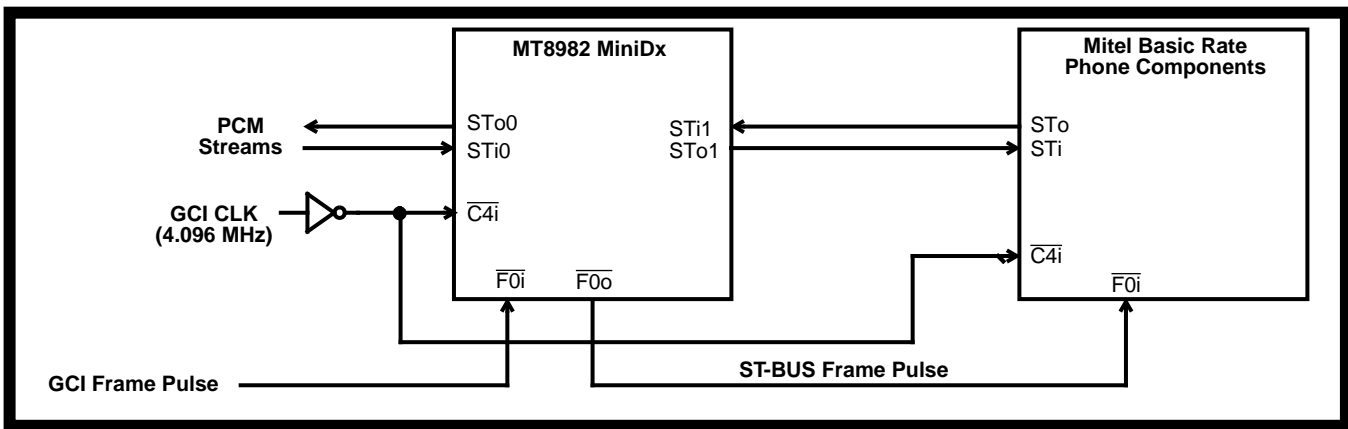

Figure 8 - GCI/ST-BUS Interface

MT8982. Therefore, to connect GCI channel B1 to ST-BUS channel B1, the MT8982 must be programmed to connect channel 5 to channel 2. The five channel offset ensures that all four basic rate channels will be switched together within one frame period, regardless which direction the data is being switched.

The five channel offset for GCI channels is required even in GCI to GCI switching systems. For example, to switch GCI channel B1 to GCI channel B2, the MT8982 must be programmed to connect channel 5 to channel 6.

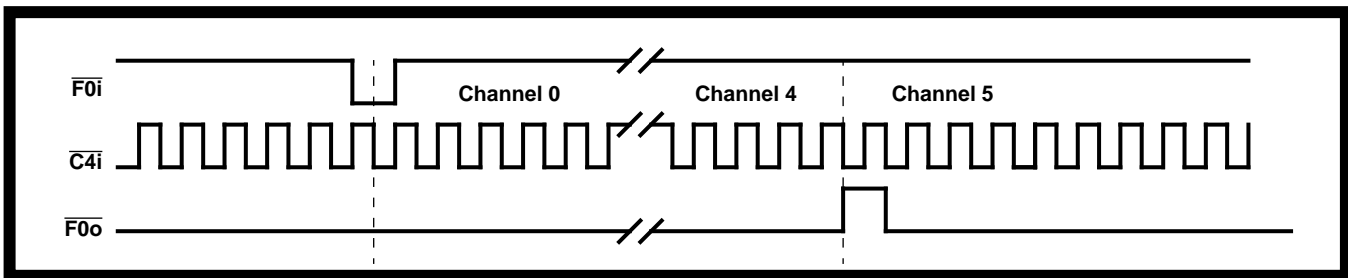

Figure 9 - ST-BUS/GCI Timing with ST-BUS as Master

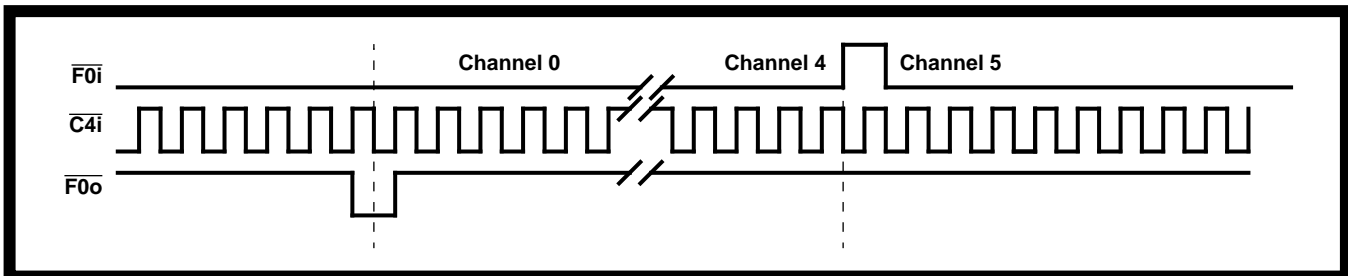

Figure 10 - ST-BUS/GCI Timing with GCI as Master

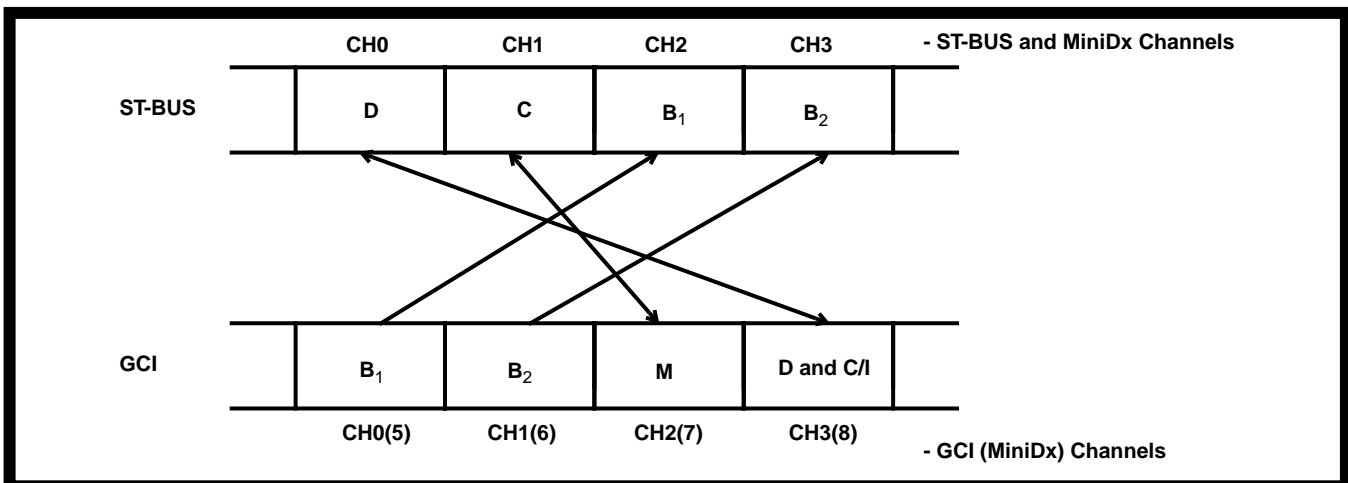

Figure 11 - Switching GCI and ST-BUS Basic Rate Access Channels

Absolute Maximum Ratings*

	Parameter	Symbol	Min	Max	Units
1	Power supply voltage $V_{DD}-V_{SS}$	$V_{DD}-V_{SS}$		6	V
2	Voltage on any pin	V_I	$V_{SS}-0.3$	$V_{DD}+0.3$	V
3	Current at any pin (other than supply)	I_O		100	mA
4	Storage temperature	T_S	-65	+150	°C
5	Package power dissipation	P_D		1000	mW

* Exceeding these values may cause permanent damage. Functional operation under these conditions is not implied.

Recommended Operating Conditions - Voltages are with respect to ground (V_{SS}) unless otherwise stated.

	Characteristics	Sym	Min	Typ [‡]	Max	Units	Test Conditions
1	Operating Temperature	T_{OP}	-40		+85	°C	
2	Power supply	V_{DD}	4.5		5.5	V	
3	Input voltage	V_I	V_{SS}		V_{DD}	V	

‡ Typical figures are at 25°C and are for design aid only: not guaranteed and not subject to production testing.

DC Electrical Characteristics - Voltages are with respect to ground (V_{SS}) unless otherwise stated.

	Characteristics	Sym	Min	Typ [‡]	Max	Units	Test Conditions
1	Operating supply voltage	V_{DD}	4.5	5.0	5.5	V	
2	Operating supply current	I_{DD}			2.0	mA	Outputs unloaded
3	Static supply current	I_{DDs}			100	μA	All inputs = V_{DD}
4	High level input	V_{IH}	2.0			V	
5	Low level input voltage	V_{IL}			0.8	V	
6	Input leakage current	I_{IH}/I_{IL}			10.0	μA	$V_{IN}=V_{SS}$ or V_{DD}
7	Low level output voltage	V_{OL}			0.4	V	$I_{OL} = 4.0$ mA
8	High level output voltage	V_{OH}	2.4			V	$I_{OH} = 2.0$ mA
9	Output low (sink) current	I_{OL}	4.0			mA	$V_{OUT}=0.4$ V
10	Output high (source) current	I_{OH}	2.0			mA	$V_{OUT}=2.4$ V, $V_{DD}=4.5$ V

‡ Typical figures are at 25°C and are for design aid only: not guaranteed and not subject to production testing.

AC Electrical Characteristics[†] - Serial Microport (see Figure 12) - Voltages are with respect to ground (V_{SS}) unless otherwise stated.

	Characteristics	Sym	Min	Typ [‡]	Max	Units	Test Conditions
1	Chip Select Setup Time	t_{CS}	5			ns	
2	RxD Input Setup Time	t_{rs}	40			ns	
3	RxD Input Hold Time	t_{rh}	0			ns	
4	TxD Output Delay	t_{td}			80	ns	$C_L=50$ pF, $R_L=1$ kΩ
5	TxD Output Tristate Delay	t_{daz}			140	ns	$C_L=50$ pF, $R_L=1$ kΩ*
6	SCLK Pulse Width High	t_{ppwh}	190			ns	
7	SCLK Pulse Width Low	t_{ppwl}	190			ns	
8	Command/Data Byte Delay Time	t_{cdbl}		2		μs	

† Timing is over recommended temperature & power supply voltages.

‡ Typical figures are at 25°C and are for design aid only: not guaranteed and not subject to production testing.

* High impedance is measured by pulling to the appropriate rail with R_L , with timing corrected to cancel time taken to discharge C_L .

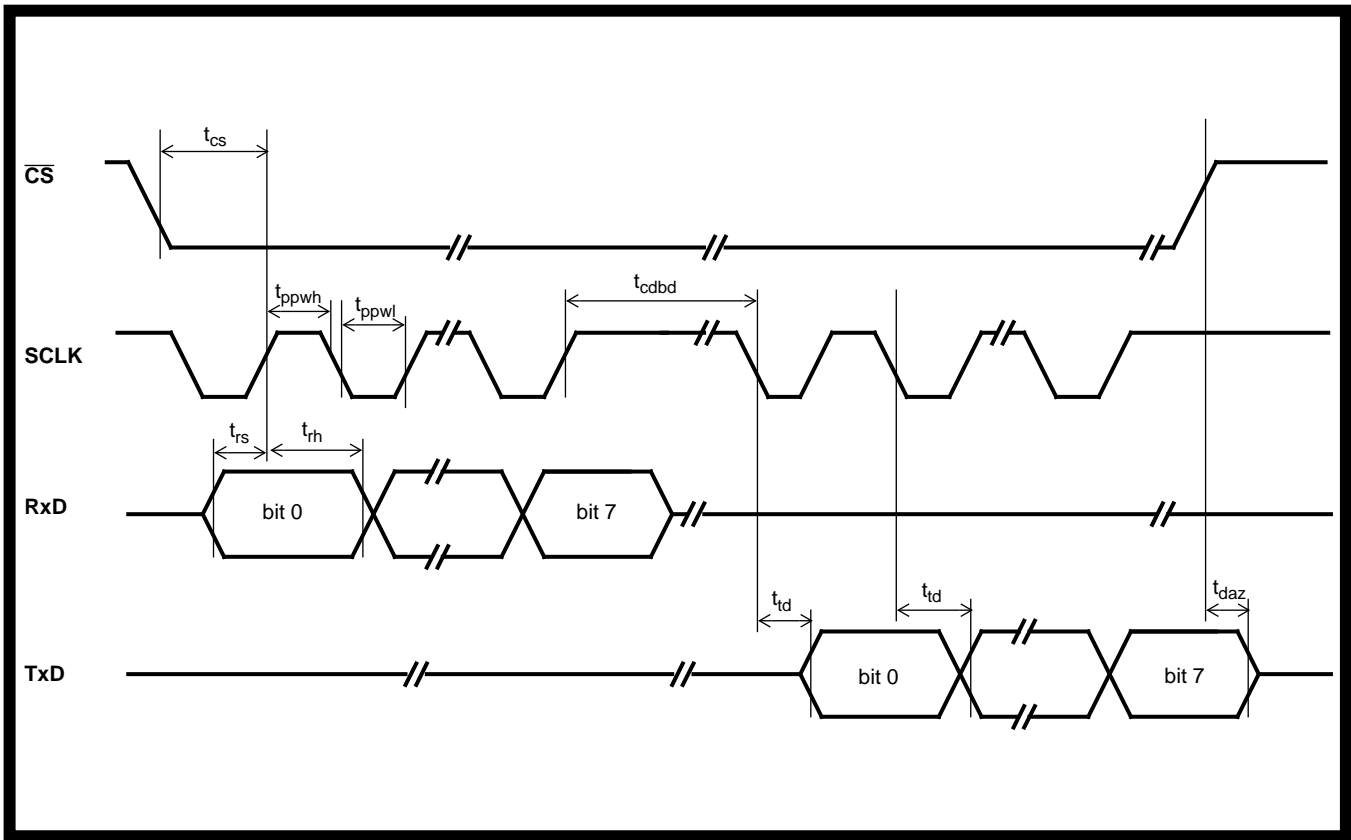

Figure 12 - Serial Microport Timing

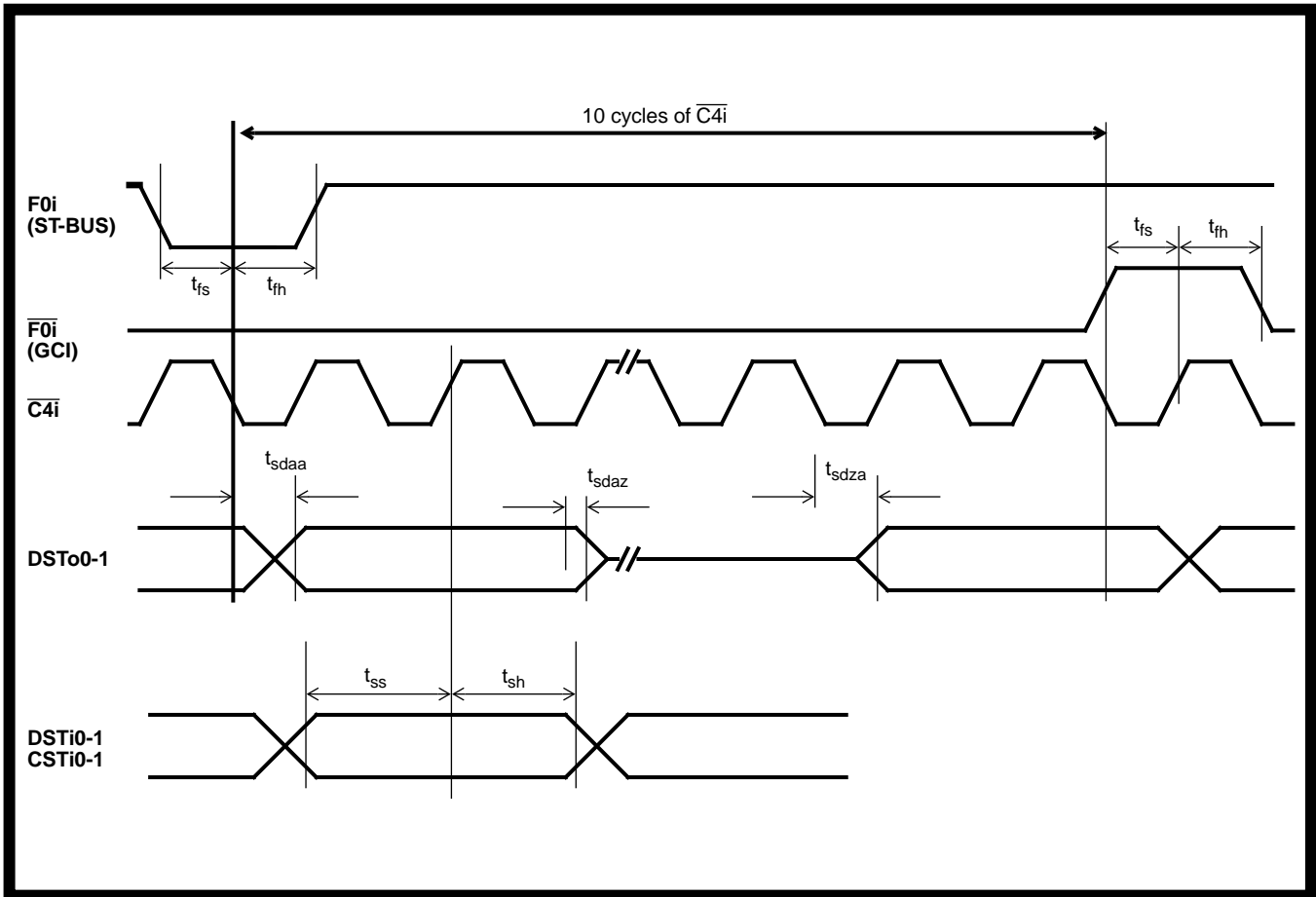

Figure 13 - TDM Bus Timing

AC Electrical Characteristics[†] - TDM Bus (See Figures 13 and 14a, 14b). Voltages are with respect to ground (V_{SS}) unless otherwise stated.

	Characteristics	Sym	Min	Typ [‡]	Max	Units	Test Conditions
1	Frame Pulse Input Setup Time	t_{fs}	10			ns	4 meg mode
2	Frame Pulse Input Hold Time	t_{fh}	5		5	ns cycles	
3	Serial Output Delay; Active to Active	t_{sdaa}			100	ns	$C_L=50pF$
4	Serial Output Delay; Active to High Z	t_{sdaz}			200	ns	$C_L=50pF$ $R_L=1k\Omega^*$
5	Serial Output Delay; High Z to Active	t_{sdza}			150	ns	$C_L=150pF$
6	Serial Input Setup Time	t_{ss}	20			ns	
7	Serial Input Hold Time	t_{sh}	10			ns	
8	Frame Pulse Output Delay	t_{fd}			70	ns	
9	ODE Low to Serial Out High Z	t_{saz}			125	ns	$C_L=50pF, R_L=1k\Omega^*$
10	ODE High to Serial Out Active	t_{sza}			50	ns	$C_L=50pF, R_L=1k\Omega$
11	C4 Clock Pulse Width Low	t_{c4l}	25	100	209	ns	$t_{c4} = 244$ ns
12	C4 Clock Pulse Width High	t_{c4h}	35	100	219	ns	$t_{c4} = 244$ ns
13	C4 Clock Period	t_{c4}	150	244		ns	

[†] Timing is over recommended temperature & power supply voltages.

[‡] Typical figures are at 25°C and are for design aid only: not guaranteed and not subject to production testing.

* High impedance is measured by pulling to the appropriate rail with R_L , with timing corrected to cancel time taken to discharge C_L .

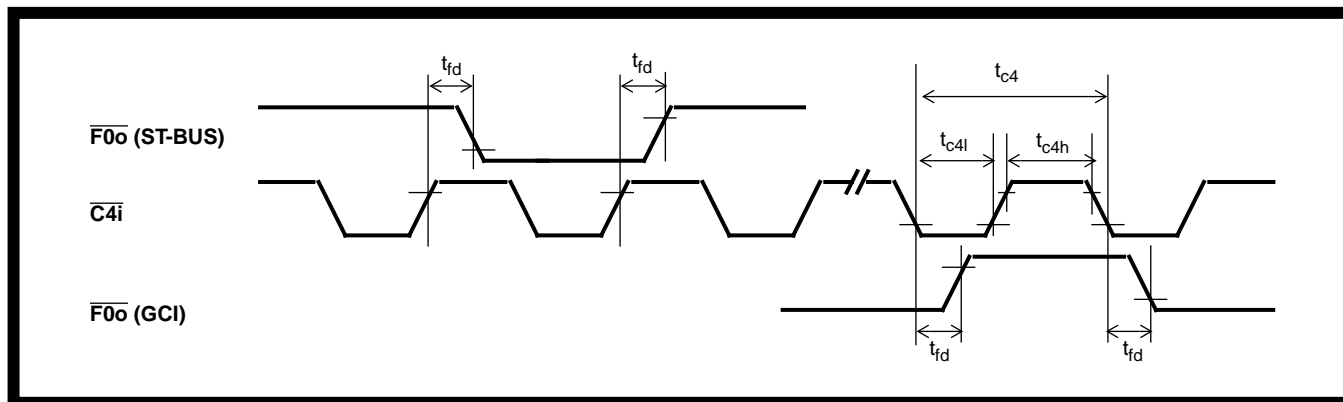

Figure 14a - TDM Bus Timing - $\overline{F0o}$ /Clock Timing

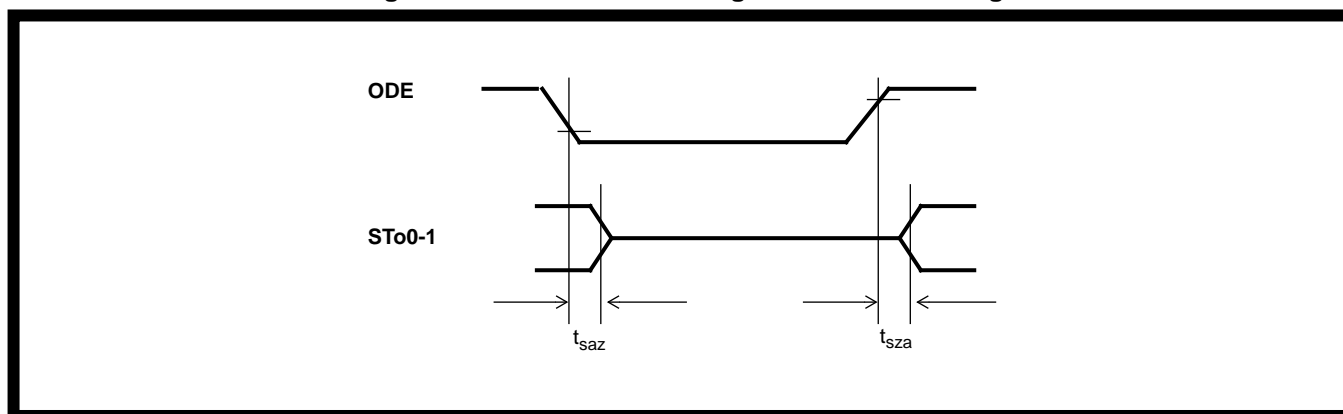
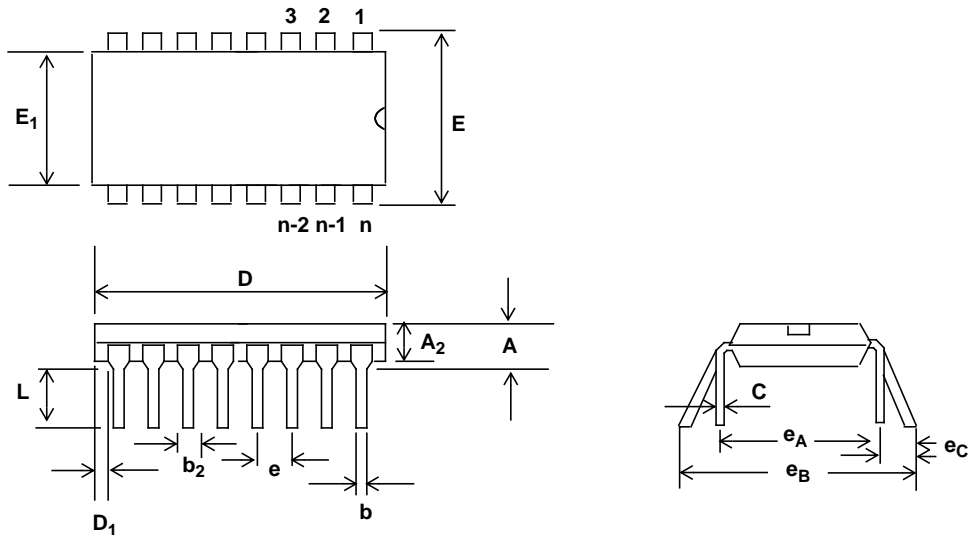

Figure 14b - ODE Timing

Notes:

Package Outlines



Notes:

- 1) Not to scale
- 2) Dimensions in inches
- 3) (Dimensions in millimeters)

Plastic Dual-In-Line Packages (PDIP) - E Suffix

DIM	8-Pin		16-Pin		18-Pin		20-Pin	
	Plastic		Plastic		Plastic		Plastic	
	Min	Max	Min	Max	Min	Max	Min	Max
A		0.210 (5.33)		0.210 (5.33)		0.210 (5.33)		0.210 (5.33)
A₂	0.115 (2.92)	0.195 (4.95)	0.115 (2.92)	0.195 (4.95)	0.115 (2.92)	0.195 (4.95)	0.115 (2.92)	0.195 (4.95)
b	0.014 (0.356)	0.022 (0.558)	0.014 (0.356)	0.022 (0.558)	0.014 (0.356)	0.022 (0.558)	0.014 (0.356)	0.022 (0.558)
b₂	0.045 (1.14)	0.070 (1.77)	0.045 (1.14)	0.070 (1.77)	0.045 (1.14)	0.070 (1.77)	0.045 (1.14)	0.070 (1.77)
C	0.008 (0.203)	0.014 (0.356)	0.008 (0.203)	0.014 (0.356)	0.008 (0.203)	0.014 (0.356)	0.008 (0.203)	0.014 (0.356)
D	0.355 (9.02)	0.400 (10.16)	0.780 (19.81)	0.800 (20.32)	0.880 (22.35)	0.920 (23.37)	0.980 (24.89)	1.060 (26.9)
D₁	0.005 (0.13)		0.005 (0.13)		0.005 (0.13)		0.005 (0.13)	
E	0.300 (7.62)	0.325 (8.26)	0.300 (7.62)	0.325 (8.26)	0.300 (7.62)	0.325 (8.26)	0.300 (7.62)	0.325 (8.26)
E₁	0.240 (6.10)	0.280 (7.11)	0.240 (6.10)	0.280 (7.11)	0.240 (6.10)	0.280 (7.11)	0.240 (6.10)	0.280 (7.11)
e	0.100 BSC (2.54)		0.100 BSC (2.54)		0.100 BSC (2.54)		0.100 BSC (2.54)	
e_A	0.300 BSC (7.62)		0.300 BSC (7.62)		0.300 BSC (7.62)		0.300 BSC (7.62)	
L	0.115 (2.92)	0.150 (3.81)	0.115 (2.92)	0.150 (3.81)	0.115 (2.92)	0.150 (3.81)	0.115 (2.92)	0.150 (3.81)
e_B		0.430 (10.92)		0.430 (10.92)		0.430 (10.92)		0.430 (10.92)
e_C	0	0.060 (1.52)	0	0.060 (1.52)	0	0.060 (1.52)	0	0.060 (1.52)

NOTE: Controlling dimensions in parenthesis () are in millimeters.

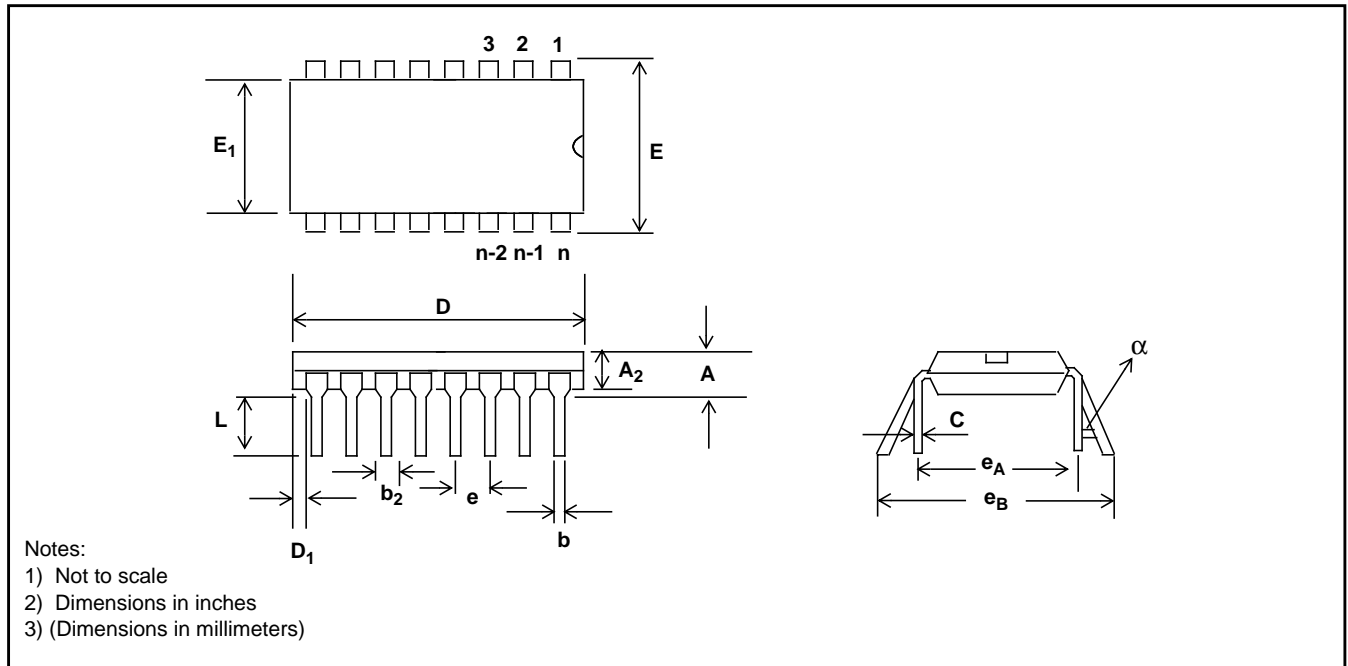

Plastic Dual-In-Line Packages (PDIP) - E Suffix

DIM	22-Pin		24-Pin		28-Pin		40-Pin	
	Plastic		Plastic		Plastic		Plastic	
	Min	Max	Min	Max	Min	Max	Min	Max
A		0.210 (5.33)		0.250 (6.35)		0.250 (6.35)		0.250 (6.35)
A₂	0.125 (3.18)	0.195 (4.95)	0.125 (3.18)	0.195 (4.95)	0.125 (3.18)	0.195 (4.95)	0.125 (3.18)	0.195 (4.95)
b	0.014 (0.356)	0.022 (0.558)	0.014 (0.356)	0.022 (0.558)	0.014 (0.356)	0.022 (0.558)	0.014 (0.356)	0.022 (0.558)
b₂	0.045 (1.15)	0.070 (1.77)	0.030 (0.77)	0.070 (1.77)	0.030 (0.77)	0.070 (1.77)	0.030 (0.77)	0.070 (1.77)
C	0.008 (0.204)	0.015 (0.381)	0.008 (0.204)	0.015 (0.381)	0.008 (0.204)	0.015 (0.381)	0.008 (0.204)	0.015 (0.381)
D	1.050 (26.67)	1.120 (28.44)	1.150 (29.3)	1.290 (32.7)	1.380 (35.1)	1.565 (39.7)	1.980 (50.3)	2.095 (53.2)
D₁	0.005 (0.13)		0.005 (0.13)		0.005 (0.13)		0.005 (0.13)	
E	0.390 (9.91)	0.430 (10.92)	0.600 (15.24)	0.670 (17.02)	0.600 (15.24)	0.670 (17.02)	0.600 (15.24)	0.670 (17.02)
E			0.290 (7.37)	.330 (8.38)				
E₁	0.330 (8.39)	0.380 (9.65)	0.485 (12.32)	0.580 (14.73)	0.485 (12.32)	0.580 (14.73)	0.485 (12.32)	0.580 (14.73)
E₁			0.246 (6.25)	0.254 (6.45)				
e	0.100 BSC (2.54)		0.100 BSC (2.54)		0.100 BSC (2.54)		0.100 BSC (2.54)	
e_A	0.400 BSC (10.16)		0.600 BSC (15.24)		0.600 BSC (15.24)		0.600 BSC (15.24)	
e_A			0.300 BSC (7.62)					
e_B				0.430 (10.92)				
L	0.115 (2.93)	0.160 (4.06)	0.115 (2.93)	0.200 (5.08)	0.115 (2.93)	0.200 (5.08)	0.115 (2.93)	0.200 (5.08)
α		15°		15°		15°		15°

Shaded areas for 300 Mil Body Width 24 PDIP only

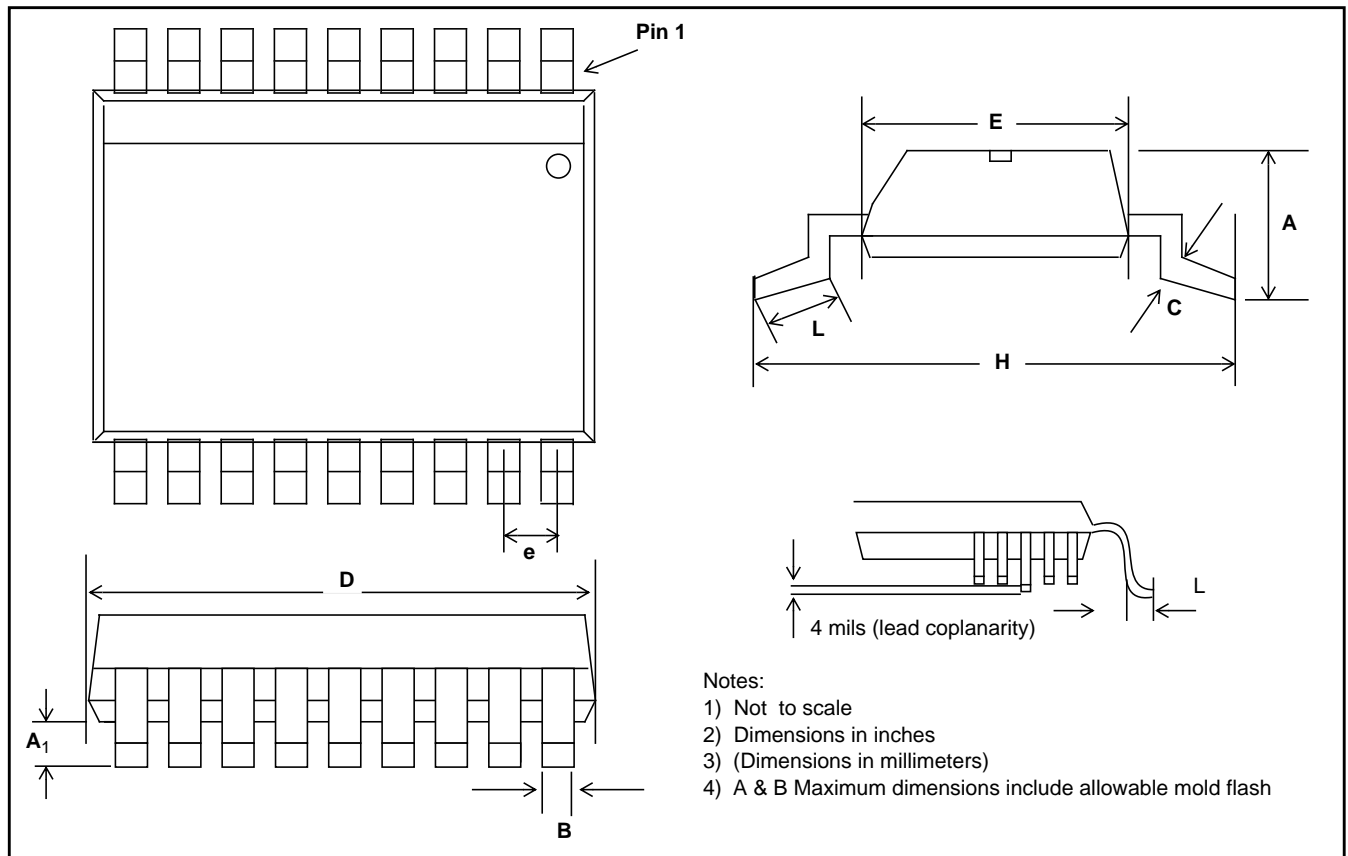

DIM	16-Pin		18-Pin		20-Pin		24-Pin		28-Pin	
	Min	Max	Min	Max	Min	Max	Min	Max	Min	Max
A	0.093 (2.35)	0.104 (2.65)	0.093 (2.35)	0.104 (2.65)	0.093 (2.35)	0.104 (2.65)	0.093 (2.35)	0.104 (2.65)	0.093 (2.35)	0.104 (2.65)
A ₁	0.004 (0.10)	0.012 (0.30)	0.004 (0.10)	0.012 (0.30)	0.004 (0.10)	0.012 (0.30)	0.004 (0.10)	0.012 (0.30)	0.004 (0.10)	0.012 (0.30)
B	0.013 (0.33)	0.020 (0.51)	0.013 (0.33)	0.030 (0.51)	0.013 (0.33)	0.020 (0.51)	0.013 (0.33)	0.020 (0.51)	0.013 (0.33)	0.020 (0.51)
C	0.009 (0.231)	0.013 (0.318)	0.009 (0.231)	0.013 (0.318)	0.009 (0.231)	0.013 (0.318)	0.009 (0.231)	0.013 (0.318)	0.009 (0.231)	0.013 (0.318)
D	0.398 (10.1)	0.413 (10.5)	0.447 (11.35)	0.4625 (11.75)	0.496 (12.60)	0.512 (13.00)	0.5985 (15.2)	0.614 (15.6)	0.697 (17.7)	0.7125 (18.1)
E	0.291 (7.40)	0.299 (7.40)	0.291 (7.40)	0.299 (7.40)	0.291 (7.40)	0.299 (7.40)	0.291 (7.40)	0.299 (7.40)	0.291 (7.40)	0.299 (7.40)
e	0.050 BSC (1.27 BSC)		0.050 BSC (1.27 BSC)		0.050 BSC (1.27 BSC)		0.050 BSC (1.27 BSC)		0.050 BSC (1.27 BSC)	
H	0.394 (10.00)	0.419 (10.65)	0.394 (10.00)	0.419 (10.65)	0.394 (10.00)	0.419 (10.65)	0.394 (10.00)	0.419 (10.65)	0.394 (10.00)	0.419 (10.65)
L	0.016 (0.40)	0.050 (1.27)	0.016 (0.40)	0.050 (1.27)	0.016 (0.40)	0.050 (1.27)	0.016 (0.40)	0.050 (1.27)	0.016 (0.40)	0.050 (1.27)

Lead SOIC Package - S Suffix

NOTES: 1. Controlling dimensions in parenthesis () are in millimeters.
2. Converted inch dimensions are not necessarily exact.

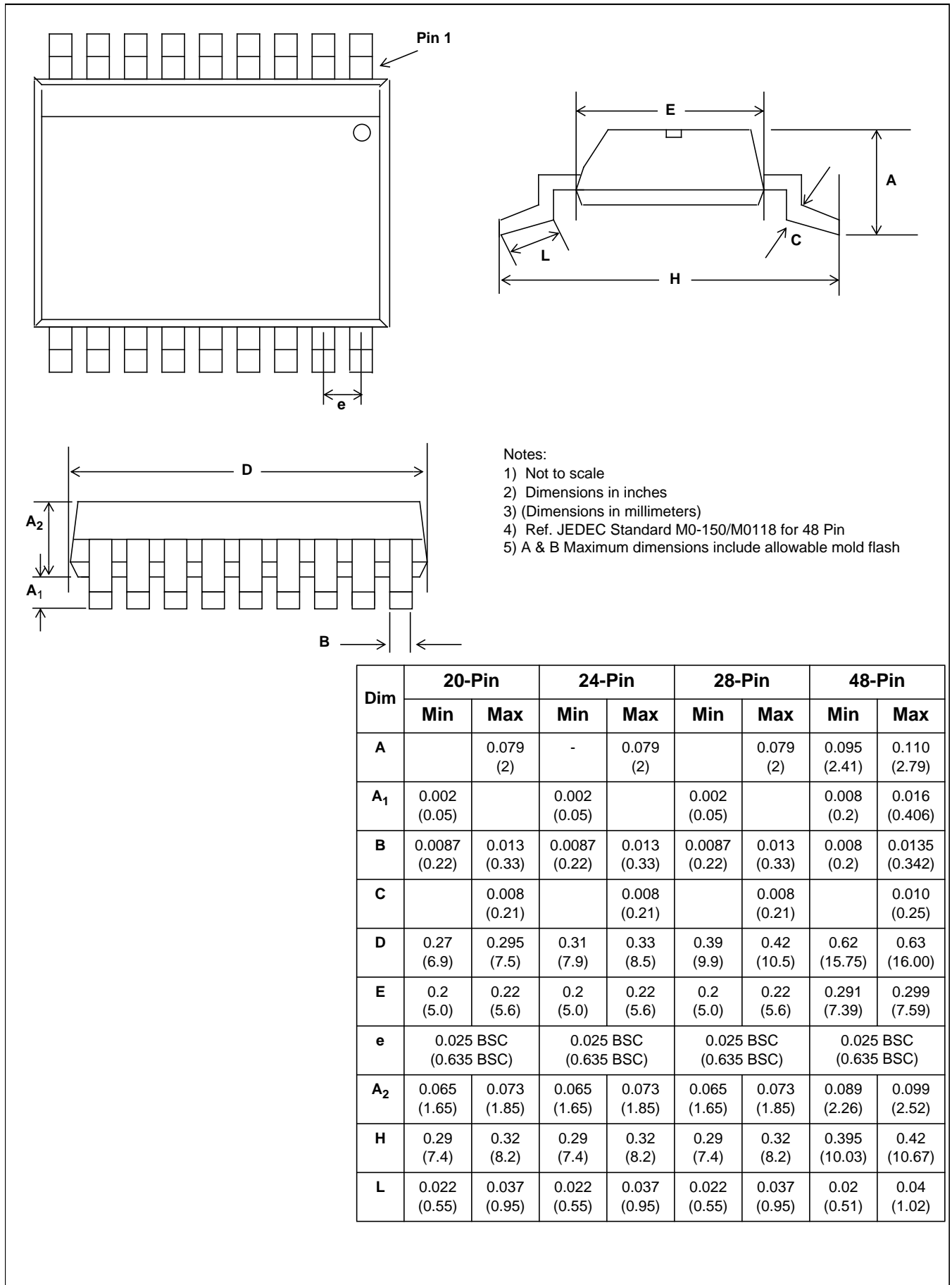

Small Shrink Outline Package (SSOP) - N Suffix



**For more information about all Zarlink products
visit our Web Site at
www.zarlink.com**

Information relating to products and services furnished herein by Zarlink Semiconductor Inc. trading as Zarlink Semiconductor or its subsidiaries (collectively "Zarlink") is believed to be reliable. However, Zarlink assumes no liability for errors that may appear in this publication, or for liability otherwise arising from the application or use of any such information, product or service or for any infringement of patents or other intellectual property rights owned by third parties which may result from such application or use. Neither the supply of such information or purchase of product or service conveys any license, either express or implied, under patents or other intellectual property rights owned by Zarlink or licensed from third parties by Zarlink, whatsoever. Purchasers of products are also hereby notified that the use of product in certain ways or in combination with Zarlink, or non-Zarlink furnished goods or services may infringe patents or other intellectual property rights owned by Zarlink.

This publication is issued to provide information only and (unless agreed by Zarlink in writing) may not be used, applied or reproduced for any purpose nor form part of any order or contract nor to be regarded as a representation relating to the products or services concerned. The products, their specifications, services and other information appearing in this publication are subject to change by Zarlink without notice. No warranty or guarantee express or implied is made regarding the capability, performance or suitability of any product or service. Information concerning possible methods of use is provided as a guide only and does not constitute any guarantee that such methods of use will be satisfactory in a specific piece of equipment. It is the user's responsibility to fully determine the performance and suitability of any equipment using such information and to ensure that any publication or data used is up to date and has not been superseded. Manufacturing does not necessarily include testing of all functions or parameters. These products are not suitable for use in any medical products whose failure to perform may result in significant injury or death to the user. All products and materials are sold and services provided subject to Zarlink's conditions of sale which are available on request.

Purchase of Zarlink's I²C components conveys a licence under the Philips I²C Patent rights to use these components in an I²C System, provided that the system conforms to the I²C Standard Specification as defined by Philips.

Zarlink, ZL and the Zarlink Semiconductor logo are trademarks of Zarlink Semiconductor Inc.

Copyright 2003, Zarlink Semiconductor Inc. All Rights Reserved.

TECHNICAL DOCUMENTATION - NOT FOR RESALE