

TOSHIBA BI-COMS INTEGRATED CIRCUIT SILICON MONOLITHIC

**T B 3 1 2 6 1 A F****RF 1CHIP IC FOR 900MHz CORDLESS TELEPHONE**

One packaging three systems PLL, IF detector, Componder.  
It is possible to reduce many external parts. This IC is  
suitable for radio section of 900MHz cordless telephone.

**FEATURES**

- Low operating voltage :  $V_{CC} = 2.7 \sim 5.5V$
- PLL operating frequency :  $f = 400 \sim 1000MHz$
- Serial control for all status
- Built-in clock output function for CPU
- Built in receiver amp
- Receiver output Level adjustment
- Variable battery alarm setting (4 thresholds)
- Built in battery saving function for intermittent receiving
- Small package: QFP52pin (0.65mm pitch)

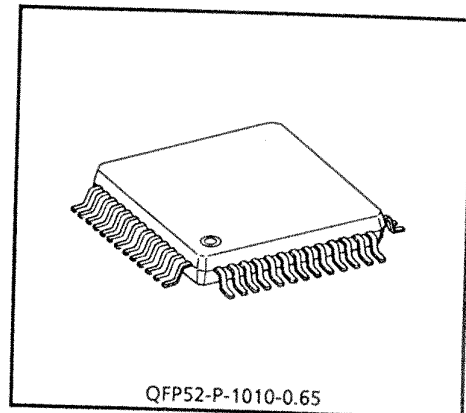

Weight : 0.45g (Typ.)



Handle with care to prevent devices from deterioration by static electricity.

980910EBA1

- TOSHIBA is continually working to improve the quality and the reliability of its products. Nevertheless, semiconductor devices in general can malfunction or fail due to their inherent electrical sensitivity and vulnerability to physical stress. It is the responsibility of the buyer, when utilizing TOSHIBA products, to observe standards of safety, and to avoid situations in which a malfunction or failure of a TOSHIBA product could cause loss of human life, bodily injury or damage to property. In developing your designs, please ensure that TOSHIBA products are used within specified operating ranges as set forth in the most recent products specifications. Also, please keep in mind the precautions and conditions set forth in the TOSHIBA Semiconductor Reliability Handbook.
- The products described in this document are subject to the foreign exchange and foreign trade laws.
- The information contained herein is presented only as a guide for the applications of our products. No responsibility is assumed by TOSHIBA CORPORATION for any infringements of intellectual property or other rights of the third parties which may result from its use. No license is granted by implication or otherwise under any intellectual property or other rights of TOSHIBA CORPORATION or others.
- The information contained herein is subject to change without notice.

BLOCK DIAGRAM

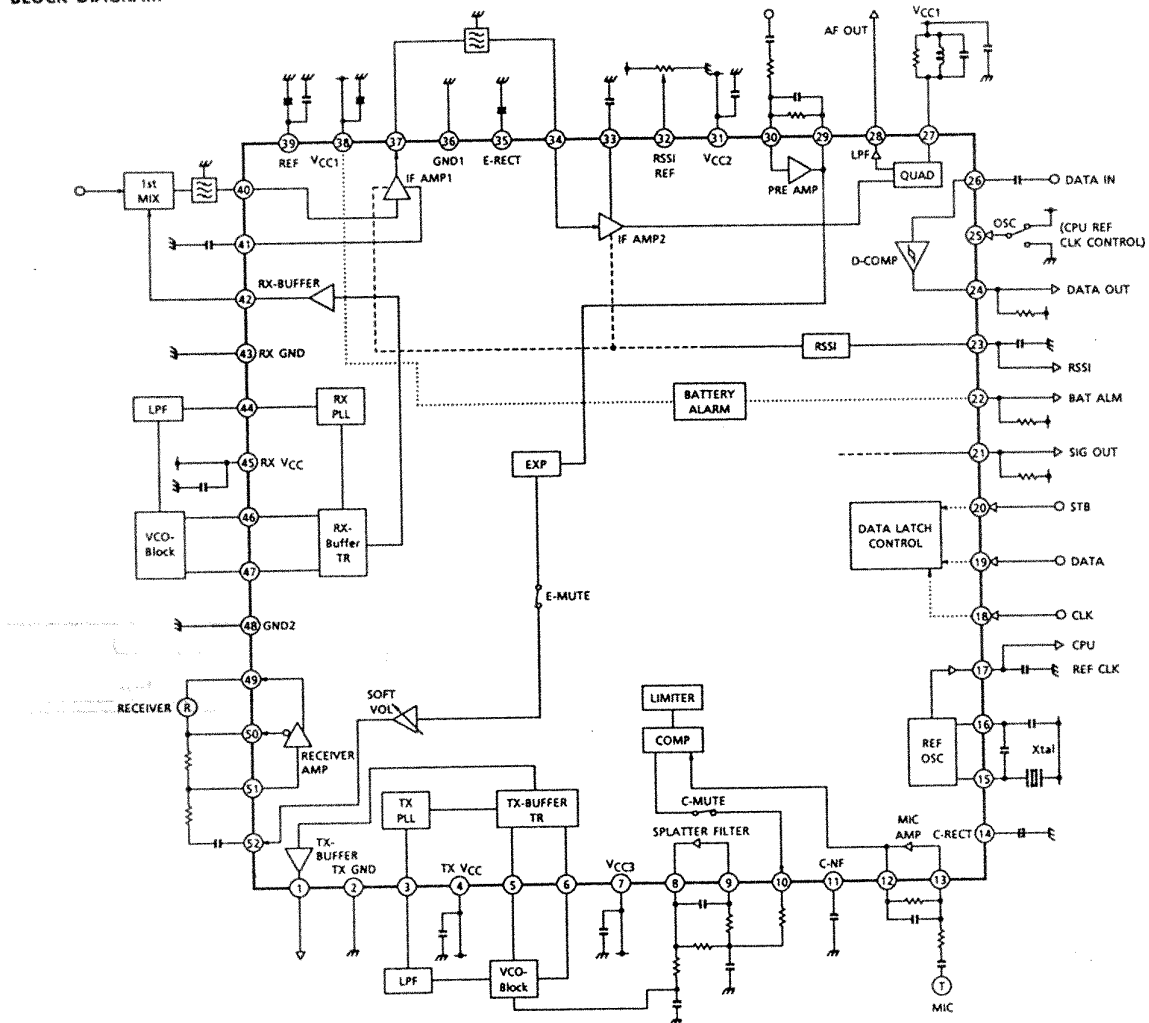

**PIN FUNCTION** (The value of resistor capacitor are typical)

PIN No.	PIN NAME	FUNCTION	INTERNAL EQUIVALENT CIRCUIT
1	TX-OUT	Output terminal of TX frequency from TX-BUFFER TRANSISTOR.	
2	TX-GND	GND terminal.	
4	TX-VCC	Power supply terminal.	
5	TX-Buffer E	Emitter terminal of TX-BUFFER TRANSISTOR.	
6	TX-Buffer B	Base terminal of TX-BUFFER TRANSISTOR.	
42	RX-OUT	Output terminal of RX frequency from RX-BUFFER TRANSISTOR.	
43	RX-GND	GND terminal.	
45	RX-VCC	Power supply terminal.	
46	RX-Buffer E	Emitter terminal of RX-BUFFER TRANSISTOR.	
47	RX-Buffer B	Base terminal of RX-BUFFER TRANSISTOR.	
3	TX-CP	Output terminal of CHARGE PUMP. CHARGE PUMP circuit outputs constant current which is varied by serial data.	
44	RX-CP	Output terminal of CHARGE PUMP. CHARGE PUMP circuit outputs constant current which is varied by serial data.	
7	VCC3	Power supply terminal.	—
8	SPLATTER-OUT	Output of Splatter Filter. And connected to Input of COMPRESSOR.	
9	SPLATTER-IN	Output of SPLATTER FILTER.	
10	COMP-OUT	Output of COMPRESSOR.	
11	C-NF	Feedback circuit of T type is formed by external capacitor with SUM AMP.	

PIN No.	PIN NAME	FUNCTION	INTERNAL EQUIVALENT CIRCUIT
12	MIC-OUT	Output of MIC AMP and connected directly to Input of COMPRESSOR.	
13	MIC-IN	Input terminal of MIC AMP.	
14	C-RECT	Connected capacitor for full-wave rectifier circuit of COMPRESSOR.	
15	REF-OSC1	REFERENCE OSCILLATOR input and output terminals.	
16	REF-OSC2	Colpitts oscillator is formed by internal emitter follower and external X'tal.	
17	OSC-OUT	Output terminal of BUFFER AMP. Output signal for MPU clock.	
18	CLK	Input terminal of clock.	
19	DATA	Input terminal of data.	
20	STB	Input terminal of strobe signal.	
21	SIG-OUT	Output terminal of detection signal. It is the open drain output.	
22	BAT-ALM	BATTERY ALARM terminals. When VCC decrease VBAT-L, this terminal outputs "H" Level. Detection voltage is controlled by data bit. This terminal is open collector output.	
23	RSSI	This terminal outputs DC voltage level according to input signal level of IF AMP. Dynamic range is around 80dB.	

PIN No.	PIN NAME	FUNCTION	INTERNAL EQUIVALENT CIRCUIT
24	DATA-OUT	Output terminal of ware from shaping circuit. This terminal is open collector output.	
25	OSC	Control terminal for REF CLK output. When voltage of this terminal is GND then whether REF CLK output or not is controlled by serial data setting, when voltage of this terminal is VCC then REF CLK always output regardless of serial data setting.	
26	D-COMP-IN	DATA COMPARATOR input terminal. This terminal input demodulated signal of DATA.	
27	QUAD	Phase shift signal input terminal of FM demodulator.	
28	AF-OUT	Demodulated signal output terminal. Carrier leak is small as LPF is built-in.	
29	PRE-OUT	Output terminal from PRE-AMP.	
30	PRE-IN	Input terminal to PRE-AMP.	
31	VCC2	Power supply terminal.	—
32	RSSI-REF	DC voltage input terminal to control detection level of RSSI COMPARATOR.	

PIN No.	PIN NAME	FUNCTION	INTERNAL EQUIVALENT CIRCUIT
33	IF2-REF	IF AMP2 input and decoupling input for bias.	
34	IF2-IN		
35	E-RECT	Terminal for rectifier of EXPANDER. Almost the same circuit as C-RECT terminal.	—
36	GND1	GND terminal.	—
37	IF-OUT	Output terminal of IF AMP.	
38	VCC1	Power supply terminal.	—
39	REF	Reference terminal through internal buffer of compander block.	—
40	IF1-IN	IF AMP1 input and decoupling input for bias.	
41	IF1-REF		
48	GND2	GND terminal.	—
49	RECEIVER 1	Receiving output for a dynamic receiver. Used for BTL output type, RO1 terminal and RO2 terminal.	
50	RECEIVER 2		
51	RECEIVER-IN		

PIN No.	PIN NAME	FUNCTION	INTERNAL EQUIVALENT CIRCUIT
52	EXP-OUT	Output of SUM amp at EXPANDER. The signal from gain cell is gained by inverted amp. The gain level can be controlled by software.	

1. General Description

TB31261F is controlled all status by serial data. This IC is included IF detector, PLL and compander. IF detector function is wideband system, dual PLL function (~1000MHz), and compander with MIC AMP and RECEIVER AMP.

POWER SUPPLY BLOCK ASSIGN

VCC1	GND1	IF-AMP1, IF-AMP2, DATA-COMP, RSSI, BATTERY-ALARM, SOFT-VOLUME, MIC-AMP, COMPRESSOR, SPLATTER-FILTER, PRE-AMP, EXPANDER, RECEIVER-AMP
VCC2		IF-AMP2, QUAD
VCC3	GND2	RX-PLL, TX-PLL, REF-OSC, DATA LATCH CONTROL
RX-VCC	RX-GND	RX-PRESCALER, RX-BUFFER, RX-BUFFER TR
TX-VCC	TX-GND	TX-PRESCALER, TX-BUFFER, TX-BUFFER TR

2. Gain Distribution for Receiving

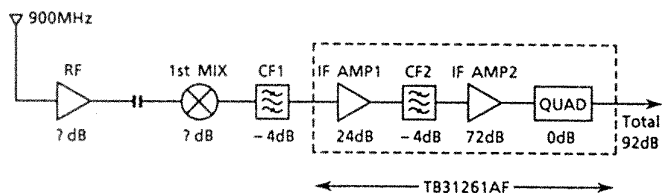

3. PLL Block

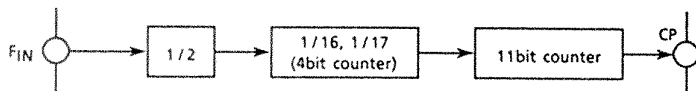

4. Data Latch Control

This block has 4 registers assigned by 2 or 3 bits CODE. DATA is read on the time of up edge of CLK. When STB receives high signal, DATA in shift register is sent into LATCH to control block which CODE indicates and the operation starts.

INPUT TIMING FOR SERIAL DATA

When both CLK "H" and DATA "L", STB "H" leads data active.

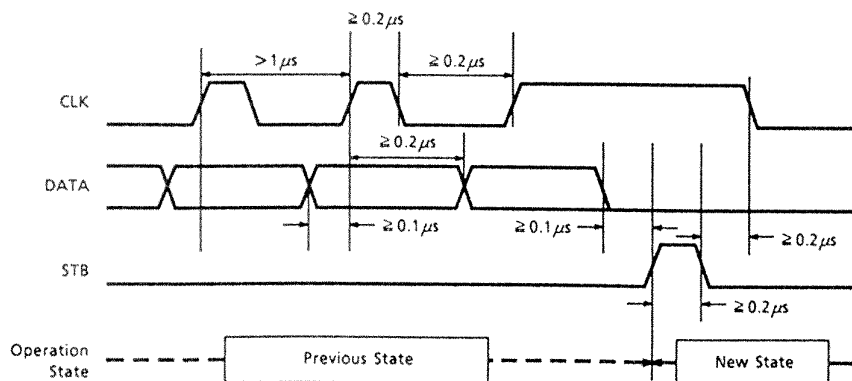



Code Assign

CODE			CONTROL BLOCK	FUNCTION
*	1	0	TX divider (18bits)	Setting frequency for TX-PLL
*	0	1	RX divider (18bits)	Setting frequency for RX-PLL
*	1	1	REF divider (12bits)	Setting phase comparison frequency
0	0	0	Option control 1	Battery save, Mute control, BAT-ALM, etc
1	0	0	Option control 2	Volume control

Serial Data Format

(1) TX DIVIDER

Swallow Counter (4bit)				Programmable Counter (11bit)											CODE		
A0	A1	A2	A3	M0	M1	M2	M3	M4	M5	M6	M7	M8	M9	M10	*	1	0

← 1st

\* Don't care

$$N = 2 \times (16M + A) \quad (480 - 65534)$$

$$A = A0 + 2A1 + 4A2 + 8A3$$

$$M = M0 + 2M1 + 4M2 + 8M3 + 16M4 + 32M5 + 64M6 + 128M7 + 256M8 + 512M9 + 1024M10$$

↑ STB

(2) RX DIVIDER

Swallow Counter (4bit)				Programmable Counter (11bit)											CODE		
A0	A1	A2	A3	M0	M1	M2	M3	M4	M5	M6	M7	M8	M9	M10	*	0	1

← 1st

\* Don't care

$$N = 2 \times (16M + A) \quad (480 - 65534)$$

$$A = A0 + 2A1 + 4A2 + 8A3$$

$$M = M0 + 2M1 + 4M2 + 8M3 + 16M4 + 32M5 + 64M6 + 128M7 + 256M8 + 512M9 + 1024M10$$

↑ STB

(3) REF DIVIDER

Programmable Counter (10bit)										CODE	
R0	R1	R2	R3	R4	R5	R6	R7	R8	R9	1	1

← 1st

$$N = R (4 - 1023)$$

$$R = R0 + 2R1 + 4R2 + 8R3 + 16R4 + 32R5 + 64R6 + 128R7 + 256R8 + 512R9$$

↑ STB

(4) Option Control 1

SIG OUT			REF	TX Control				RX Control				BAT-ALM			CODE		
TXLD	RXLD	RSSI	XOSC	RF	AF	CP	MUT	RF	AF	CP	MUTE	BA1	BA2	BA3	0	0	0

← 1st

↑ STB

## 1. Battery Saving Control

0	Operation
1	Battery Saving

BIT	CONTROL BLOCK
RX-RF	RX-PLL, RX-BUFFER TR, IF AMP, QUAD, DATA COMP, RSSI
RX-AF	PRE AMP, EXPANDER, RECEIVER AMP
TX-RF	TX-PLL, TX-BUFFER TR
TX-AF	MIC AMP, COMPRESSOR, SPLATTER-FILTER
REF-OSC	REF-OSC

## 2. Charge Pump Output Current Select

CP	Current
0	400 $\mu$ A
1	800 $\mu$ A

## 3. Mute Control

0	Operation
1	Mute On

TX-MUTE control for COMPRESSOR output.

RX-MUTE control for EXPANDER output.

## 4. BATTERY ALARM Detection Setting

This IC has 4 threshold levels for detection of battery dropping.

These threshold levels are given by below table.

BA1	BA2	BA3	DET. VOLTAGE	BAT-ALM OUTPUT	
				DET.VOL > V <sub>CC</sub>	DET.VOL < V <sub>CC</sub>
0	0	1	3.00V	H	L
0	1	0	3.15V	H	L
0	1	1	3.30V	H	L
1	0	0	3.45V	H	L
1	1	1	BS	H	

## 5. SIG OUT Selection

SIG OUT terminal generates combination states of RX and TX LOCK DETECTOR and RSSI.

IF you set plural BIT to 1, then SIG OUT is "AND" output of each FUNCTION.

0	OFF
1	OUT PUT

BIT	FUNCTION
TXLD	TX-PLL LOCK DETECTOR
RXLD	RX-PLL LOCK DETECTOR
RSSI	RSSI COMPARATOR OUTPUT

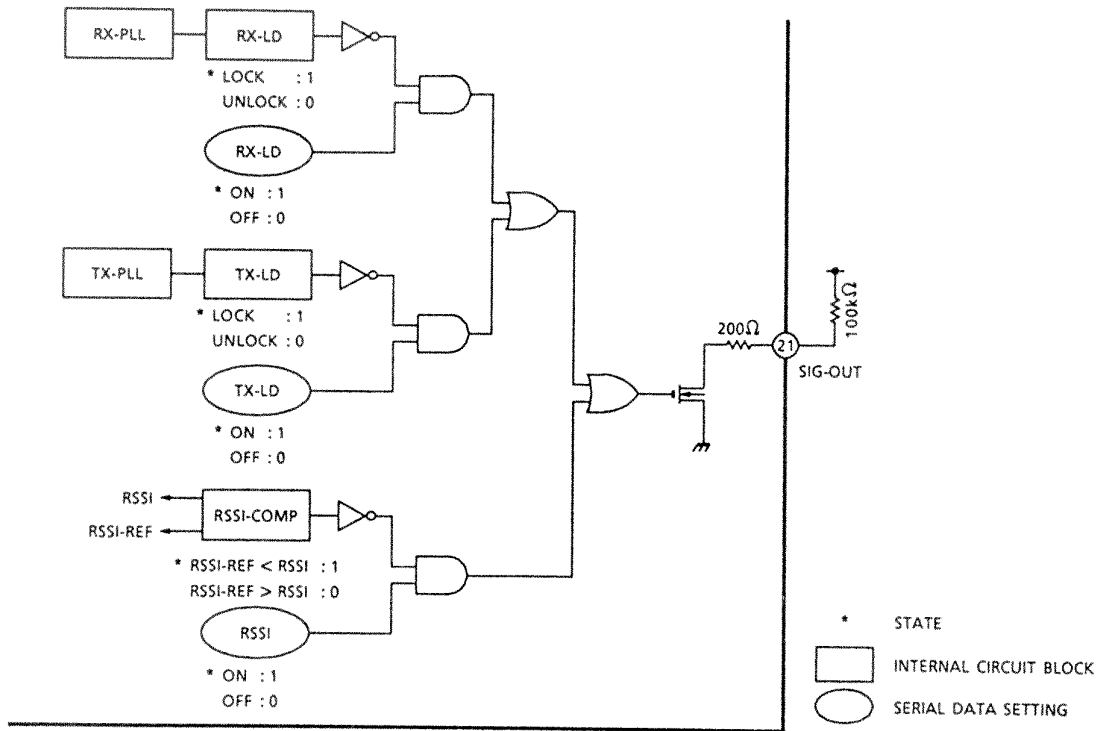

			Bit																																
INPUT	SERIAL DATA SETTING	RX-LD	0	1	0	1	0	1	0	1	0	1	0	1	0	1	0	1	0	1	0	1	0	1	0	1	0	1	0	1					
		TX-LD	0	0	1	1	0	0	1	1	0	0	1	1	0	0	1	1	0	0	1	1	0	0	1	1	0	0	1	1	0	0	1	1	
		RSSI	0	0	0	0	1	1	1	1	0	0	0	0	1	1	1	1	0	0	0	0	1	1	1	1	0	0	0	0	1	1	1	1	
	CIRCUIT STATE	RX-LD	0	0	0	0	0	0	0	1	1	1	1	1	1	1	0	0	0	0	0	0	0	0	0	0	0	0	0	0	0	0	0	0	
		TX-LD	0	0	0	0	0	0	0	0	0	0	0	0	0	0	0	0	0	0	0	0	0	0	0	0	0	0	0	0	0	0	0	0	0
		RSSI	0	0	0	0	0	0	0	0	0	0	0	0	0	0	0	0	0	0	0	0	0	0	0	0	0	0	0	0	0	0	0	0	0
OUTPUT	SIG-OUT	1	0	0	0	0	0	0	1	1	0	0	0	0	0	0	0	0	0	0	0	0	0	0	0	0	0	0	0	0	0	0	0	0	

			Bit																																	
INPUT	SERIAL DATA SETTING	RX-LD	0	1	0	1	0	1	0	1	0	1	0	1	0	1	0	1	0	1	0	1	0	1	0	1	0	1	0	1						
		TX-LD	0	0	1	1	0	0	1	1	0	0	1	1	0	0	1	1	0	0	1	1	0	0	1	1	0	0	1	1	0	0	1	1		
		RSSI	0	0	0	0	1	1	1	1	0	0	0	0	1	1	1	1	0	0	0	0	1	1	1	1	0	0	0	0	1	1	1	1		
	CIRCUIT STATE	RX-LD	0	0	0	0	0	0	0	1	1	1	1	1	1	1	0	0	0	0	0	0	0	0	0	0	0	0	0	0	0	0	0	0	0	
		TX-LD	0	0	0	0	0	0	0	0	0	0	0	0	0	0	0	0	0	0	0	0	0	0	0	0	0	0	0	0	0	0	0	0	0	0
		RSSI	1	1	1	1	1	1	1	1	1	1	1	1	1	1	1	1	1	1	1	1	1	1	1	1	1	1	1	1	1	1	1	1	1	1
OUTPUT	SIG-OUT	1	0	0	0	1	0	0	0	1	1	0	0	1	1	0	0	1	0	1	0	1	0	1	0	1	0	1	0	1	1	1	1	1	1	

(5) Option Control 2

RECEIVER OUTPUT LEVEL CONTROL

It is possible to volume control to set these bits.

And this register includes TEST bits which must be set 0 in customer side.

1.5dB steps from 0dB to -22.5dB.

Receiver Volume					CODE		
VOL1	VOL2	VOL3	VOL4	*	1	0	0

\* You have to be sure to set 0.

VOL1	VOL2	VOL3	VOL4	GAIN
0	0	0	0	0dB
0	0	0	1	-1.5dB
0	0	1	0	-3.0dB
0	0	1	1	-4.5dB
0	1	0	0	-6.0dB
0	1	0	1	-7.5dB
0	1	1	0	-9.0dB
0	1	1	1	-10.5dB
1	0	0	0	-12.0dB
1	0	0	1	-13.5dB
1	0	1	0	-15.0dB
1	0	1	1	-16.5dB
1	1	0	0	-18.0dB
1	1	0	1	-19.5dB
1	1	1	0	-21.0dB
1	1	1	1	-22.5dB

## MAXIMUM RATINGS (Ta = 25°C)

CHARACTERISTIC	SYMBOL	RATING	UNIT
Power Supply Voltage	V <sub>CC</sub>	6	V
Power Dissipation	P <sub>D</sub>	900 *1	mW
Operating Temperature	T <sub>opr</sub>	-20~70	°C
Storage Temperature	T <sub>stg</sub>	-50~150	°C

\*1 IC single unit

## ELECTRICAL CHARACTERISTICS

TOTAL CHARACTERISTIC (V<sub>CC</sub> = 3.6V, Ta = 25°C, Δf = 25kHz, f<sub>mod</sub> = 1kHz)

CHARACTERISTIC	SYMBOL	TEST CIR-CUIT	TEST CONDITION	MIN.	TYP.	MAX.	UNIT
Operating Power Supply Voltage	V <sub>CC</sub> (opr)	—	—	2.7	3.6	5.5	V
Consumption Current 1	I <sub>CC1</sub>	1	ALL ON (Not including VCO current)	12.3	24.6	33.3	mA
Consumption Current 2	I <sub>CC2</sub>	1	RX-RF ON (Not including VCO current)	7.7	11.6	15.7	mA
Consumption Current 3	I <sub>CC3</sub>	1	RX-AF ON	2.4	3.5	4.8	mA
Consumption Current 4	I <sub>CC4</sub>	1	TX-RF ON (Not including VCO current)	2.6	7.1	9.6	mA
Consumption Current 5	I <sub>CC5</sub>	1	TX-AF ON	0.8	2.1	2.9	mA
Alarm Supply Current	I <sub>CC</sub> (A)	1	RL = 100kΩ V <sub>BAT-L</sub> = 3.30V ± 1%	—	160	200	μA
Supply Current at BS	I <sub>CC</sub> (BS)	1	ALL OFF	—	0	50	μA
V <sub>REF</sub> Voltage	V <sub>REF</sub>	1	—	1.0	1.45	1.8	V
Data Input Threshold	V <sub>IH</sub>	—	—	0.8 × V <sub>CC</sub>	V <sub>CC</sub>	5.5	V
	V <sub>IL</sub>	—	—	-0.2	0	0.2 × V <sub>CC</sub>	
Data Input Current	I <sub>IH</sub>	—	V <sub>IH</sub> = V <sub>CC</sub>	—	0	1	μA
	I <sub>IL</sub>	—	V <sub>IL</sub> = GND	—	0	1	
CK Input Frequency	f <sub>CK</sub>	—	—	—	100	1000	kHz

DETECTOR SECTION (Unless Otherwise Specified,  $V_{CC} = 3.6V$ ,  $T_a = 25^\circ C$ )  
BATTERY ALARM

CHARACTERISTIC	SYMBOL	TEST CIR-CUIT	TEST CONDITION	MIN.	TYP.	MAX.	UNIT
Detection Voltage 1	V <sub>BAT-L</sub>	1	—	2.85	3.00	3.15	V
	V <sub>BAT-H</sub>		—	—	3.08	3.23	
Detection Voltage 2	V <sub>BAT-L</sub>	1	—	2.99	3.15	3.31	V
	V <sub>BAT-H</sub>		—	—	3.25	3.41	
Detection Voltage 3	V <sub>BAT-L</sub>	1	—	3.14	3.30	3.47	V
	V <sub>BAT-H</sub>		—	—	3.40	3.57	
Detection Voltage 4	V <sub>BAT-L</sub>	1	—	3.28	3.45	3.62	V
	V <sub>BAT-H</sub>		—	—	3.55	3.73	
Output Low Level Voltage	V <sub>OL1</sub>	1	I <sub>SINK</sub> = 0.1mA		0.1	0.3	V
Output Leak Current	I <sub>LEAK1</sub>	1	V <sub>ALM</sub> = 3.6V		0	5	μA

DATA COMPARATOR

CHARACTERISTIC	SYMBOL	TEST CIR-CUIT	TEST CONDITION	MIN.	TYP.	MAX.	UNIT
Minimum Detection Level	V <sub>TH1</sub>	2	f = 500Hz	—	—	50	mVrms
Output Low Level Voltage	V <sub>OL2</sub>	1	I <sub>SINK</sub> = 0.2mA	—	0.1	0.3	V
Output Leak Current	I <sub>LEAK2</sub>	1	H Level	—	0	5	μA
Duty Ratio	Duty	2	V <sub>IN</sub> (Data comparator input) = 120mVrms, "H" Level, F = 1kHz	46	—	54	%

SIG OUT DETECTION

CHARACTERISTIC	SYMBOL	TEST CIR-CUIT	TEST CONDITION	MIN.	TYP.	MAX.	UNIT
Output Low Level Voltage	V <sub>OL3</sub>	1	I <sub>SINK</sub> = 0.2mA	—	0.1	0.5	V
Output Leak Current	I <sub>LEAK3</sub>	1	SIG out off mode	—	0	5	μA

PLL SECTION (Unless Otherwise Specified,  $V_{CC} = 3.6V$ ,  $T_a = 25^\circ C$ )

CHARACTERISTIC	SYMBOL	TEST CIR-CUIT	TEST CONDITION	MIN.	TYP.	MAX.	UNIT
PLL Operating Frequency	$f_{IN}$	1	—	400	900	1000	MHz
PLL Input Sensitivity	$V_{IN}$	1	—	90	103	110	dB $\mu$ V
XIN Operating Frequency	$f_{XIN}$	1	$V_{IN} = 110dB\mu V$	2	4	24	MHz
XIN Input Sensitivity	$V_{XIN}$	1	$f_{IN} = 4MHz$	100	110	115	dB $\mu$ V
Charge Pump Output Current	$I_{CP1}$	—	$V_{CP} = 1.8V$	—	$\pm 400$	—	$\mu A$
	$I_{CP2}$	—	$V_{CP} = 1.8V$	—	$\pm 800$	—	
Charge Pump Leak Current	$I_{LEAK4}$	1	—	—	0	5	$\mu A$

RECEIVING SECTION ( $V_{CC} = 3.6V$ ,  $T_a = 25^\circ C$ ,  $\Delta f = 25kHz$ ,  $f_{mod} = 1kHz$ )

CHARACTERISTIC	SYMBOL	TEST CIR-CUIT	TEST CONDITION	MIN.	TYP.	MAX.	UNIT
12dB SINAD Sensitivity	12dB SINAD	—	INPUT 50 $\Omega$	—	13.5	—	dB $\mu$ VEMF
IF AMP1 Gain	GIF1	2	—	—	24	—	dB
IF AMP2 Gain	GIF2	—	—	—	72	—	dB
Demodulated Output level	$V_{OD}$	2	$V_{IN} (IF1) = 70dB\mu VEMF$	90	117	144	mVrms
S/N Ratio	SN	2	$V_{IN} (IF1) = 70dB\mu VEMF$	55	69.5	—	dB
AM Rejection Ratio	AMR	2	$V_{IN} (IF1) = 70dB\mu VEMF$	—	68.3	—	dB
IFAMP1 input Resistance	RIF1IN	—	IF1-IN	—	330	—	$\Omega$
IFAMP1 Output Resistance	RIF1OUT	—	IF1-OUT	—	330	—	$\Omega$
IFAMP2 Input Resistance	RIF2IN	—	IF2-IN	—	330	—	$\Omega$
RSSI Output Voltage	VRSSI1	2	$V_{IN} (IF1-IN) = 20dB\mu VEMF$	0.15	0.35	0.50	V
	VRSSI2	2	$V_{IN} (IF1-IN) = 70dB\mu VEMF$	1.36	1.70	2.06	

AUDIO SECTION (Unless Otherwise Specified,  $V_{CC} = 3.6V$ ,  $f_{in} = 1kHz$ ,  $T_a = 25^\circ C$ )  
MIC AMP + COMPRESSOR

CHARACTERISTIC	SYMBOL	TEST CIRCUIT	TEST CONDITION	MIN.	TYP.	MAX.	UNIT
COMP Input Reference Level	$V_{refC}$	2	$V_{OM} = -10dBV$	-11.3	-9.1	-7.3	dBV
COMP Output Deviation	$V_{OC}$	2	$V_{OM} = -30dBV$	-0.7	-0.1	+0.7	dB
MIC AMP Voltage Gain Setting Range	$V_{GRM}$	—		—	0	—	dB
Total Harmonic Distortion	$THD_C$	2	$V_{OM} = -10dBV$	—	0.3	1	%
Output Noise Level	$V_{NOC}$	2	Input-GND Short	—	-62	-48	dBV
Limiting Level	$V_{lim1}$	—	COMP OUT, $V_{IM} = 0dBV$	—	1.3	—	Vp-p
	$V_{lim2}$	—	MIC OUT, $V_{IM} = 0dBV$	—	2.5	—	
MUTE Output Level	$V_{MUTE}$	—	—	—	-90	—	dBV
Crosstalk EC	$CT_{EC}$	—	$V_{IP} = 0dBV$	—	-36.7	—	dBV
Attack Time	$T_{AC}$	—	$V_{IM} = -46 \rightarrow -34dBV$	—	3.5	—	ms
Recovery Time	$T_{RC}$	—	$V_{IM} = -34 \rightarrow -46dBV$	—	5.0	—	ms

PRE AMP + EXPANDER + RECEIVER AMP

CHARACTERISTIC	SYMBOL	TEST CIRCUIT	TEST CONDITION	MIN.	TYP.	MAX.	UNIT
EXP Input Reference Level	$V_{refE}$	2	$V_{OP} = -10dBV$	-13.6	-10.9	-8.0	dBV
EXP Output Deviation	$V_{OE}$	2	$V_{OP} = -35dBV$	-1.0	+0.3	+1.8	dB
RO1 Voltage Gain	$G_{RO1}$	—	$R_L = 150\Omega$	—	6	—	dB
Total Harmonic Distortion	$THD_1$	2	$R_L = 150\Omega$ , $V_{OE} = -15dBV$	—	0.65	1.5	%
Output Noise Level	$V_{NOR}$	2	Input-GND Short	—	-76	-65	dBV
Maximum Output Level	$D_R$	2	$THD = 3\%$ , $150\Omega$ load	—	2.63	—	Vp-p
MUTE Output Level	$V_{MUTE}$	—	—	—	-65	—	dBV
PRE AMP Voltage Gain Setting Range	$V_{GRp}$	—	—	0	—	20	dB
RECEIVER AMP Voltage Gain Setting Range	$V_{GRr}$	—	—	6	—	20	dB
Offset Voltage	$V_{OF2}$	1	RO1·RO2	-50	0	50	mV
Crosstalk CE	$CT_{CE}$	—	$V_{IM} = -20dBV$	—	-79	—	dB
Attack Time	$T_{AE}$	—	$V_{IP} = -18 \rightarrow -12dBV$	—	8.5	—	ms
Recovery Time	$T_{RE}$	—	$V_{IP} = -12 \rightarrow -18dBV$	—	4.5	—	ms



## FILTER AMP

CHARACTERISTIC	SYMBOL	TEST CIR-CUIT	TEST CONDITION	MIN.	TYP.	MAX.	UNIT
Voltage Gain	G5	—	—	—	0	—	dB
Maximum Output Level	DR5	—	THD = 3%	—	3	—	Vp-p
Input Bias Current	I <sub>BIAS</sub>	1	—	—	1.5	2.5	μA
Offset Voltage	V <sub>OF5</sub>	1	—	-35	0	35	mV

TEST CIRCUIT 1

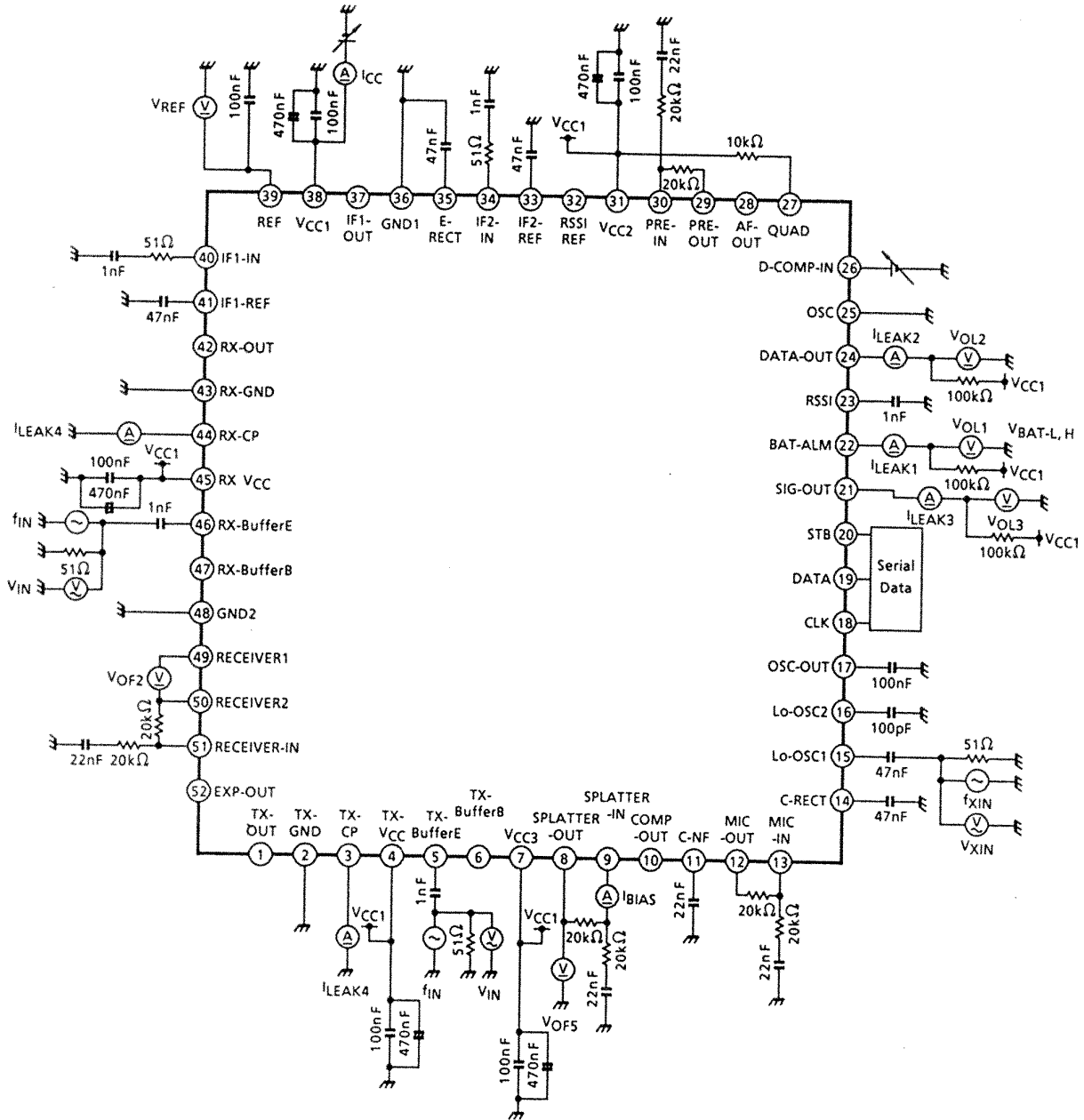

TEST CIRCUIT 2

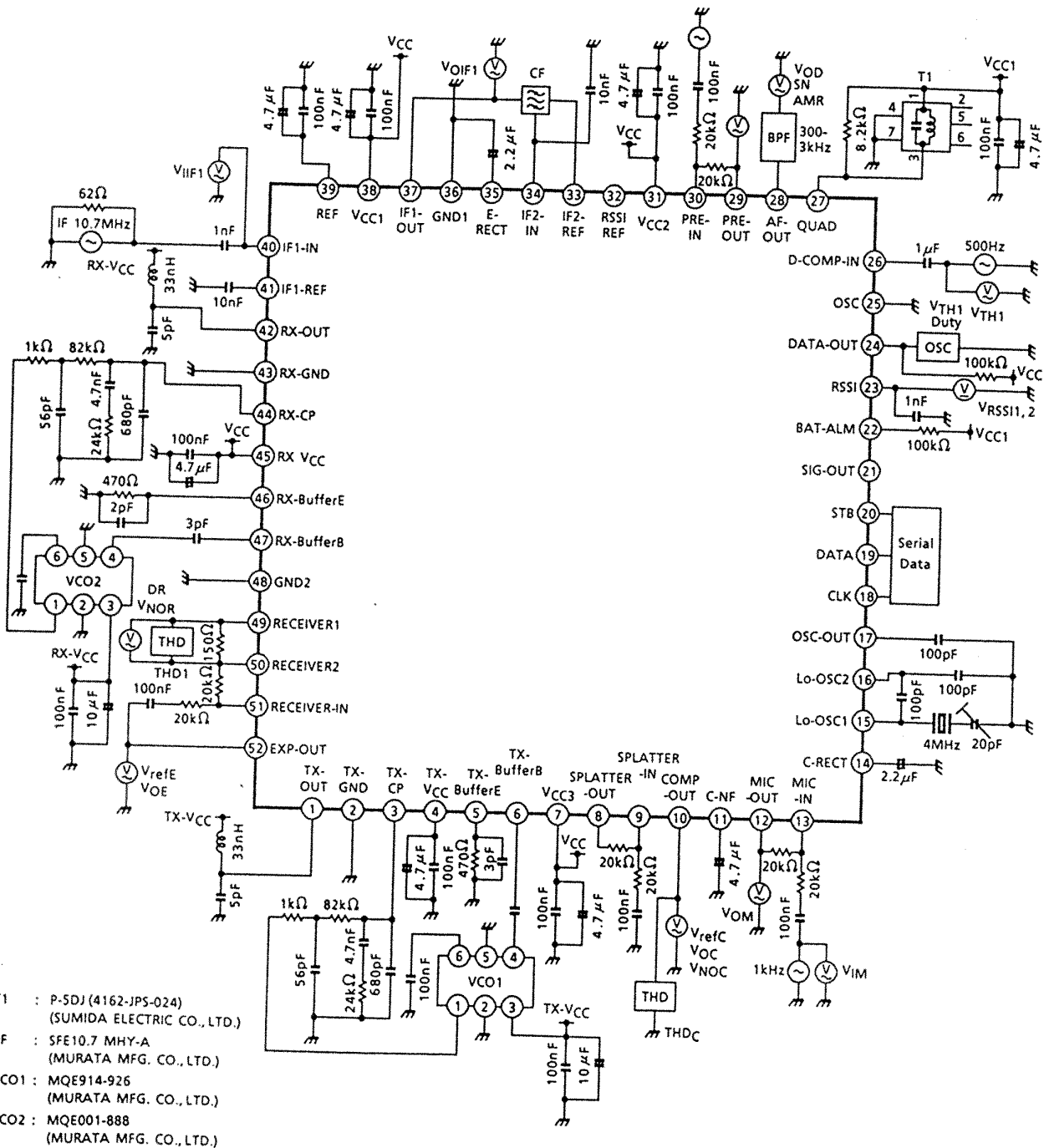

- T1 : P-5DJ (4162-JPS-024)  
(SUMIDA ELECTRIC CO., LTD.)
- CF : SFE10.7 MHY-A  
(MURATA MFG. CO., LTD.)
- VCO1 : MQE914-926  
(MURATA MFG. CO., LTD.)
- VCO2 : MQE001-888  
(MURATA MFG. CO., LTD.)

CURRENT CONSUMPTION -  
POWER SUPPLY VOLTAGE

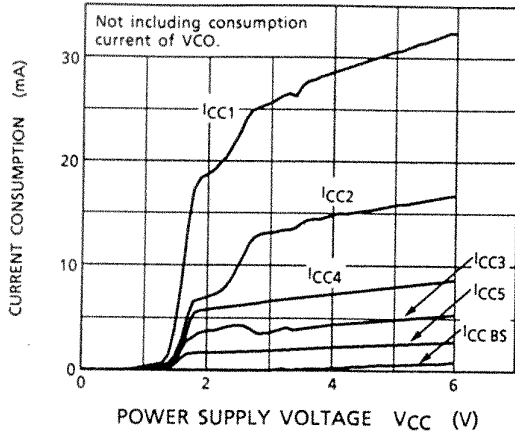

CHARGE PUMP OUTPUT CURRENT -  
CHARGE PUMP VOLTAGE RX-CP (N-CH)

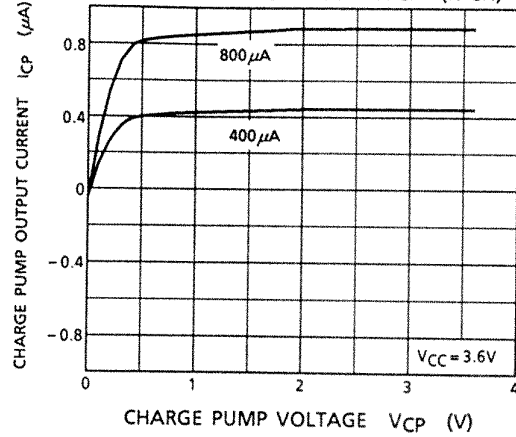

CHARGE PUMP OUTPUT CURRENT -  
CHARGE PUMP VOLTAGE RX-CP (P-CH)

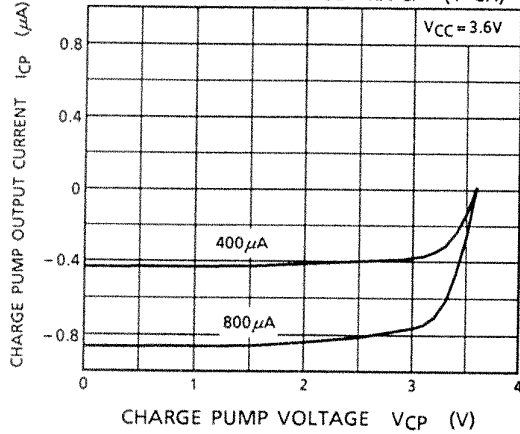

CHARGE PUMP OUTPUT CURRENT -  
CHARGE PUMP VOLTAGE TX-CP (N-CH)

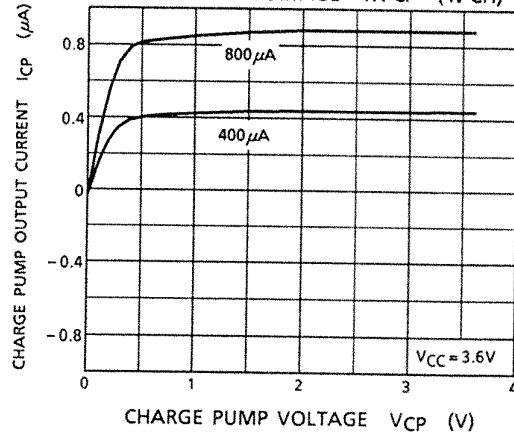

CHARGE PUMP OUTPUT CURRENT -  
CHARGE PUMP VOLTAGE TX-CP (P-CH)

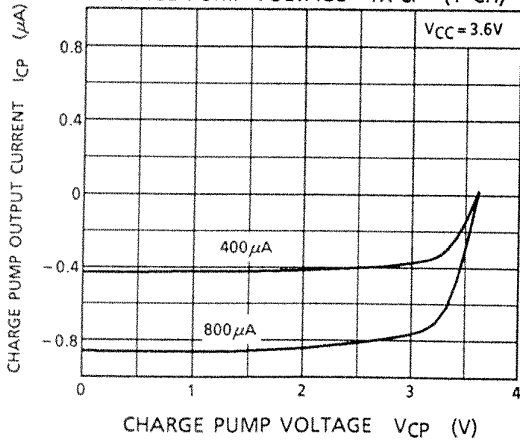

IF CHARACTERISTICS (INPUT 50Ω)

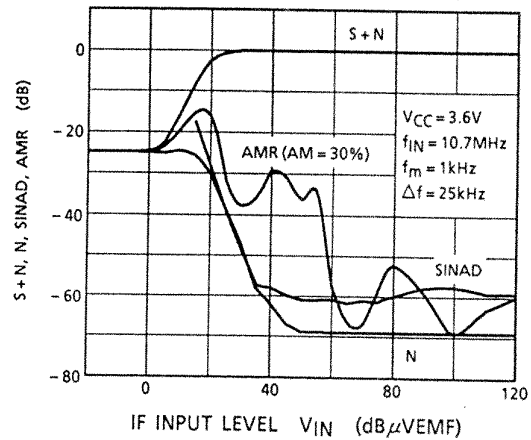

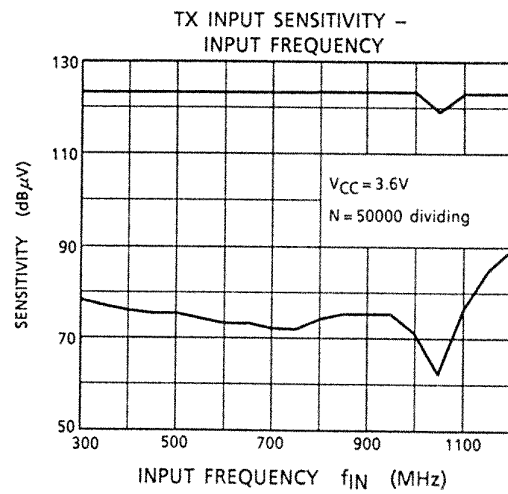
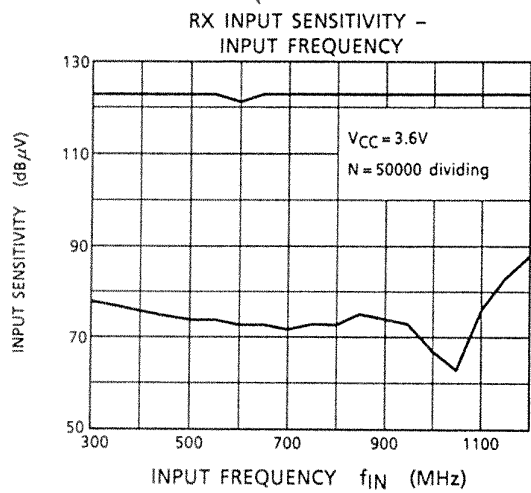
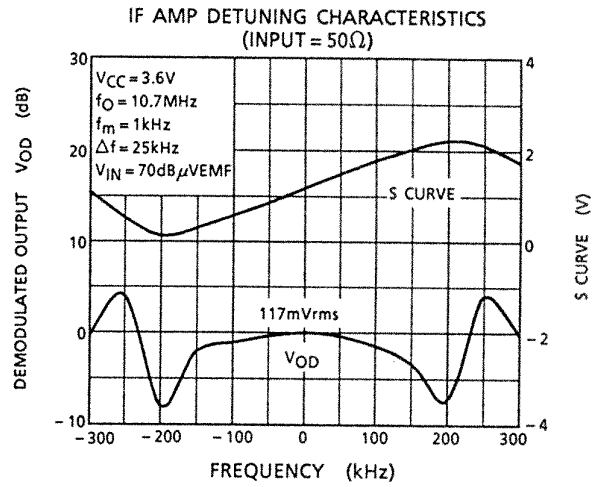
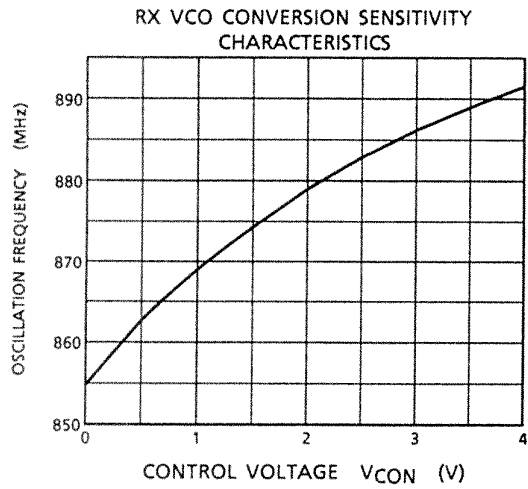
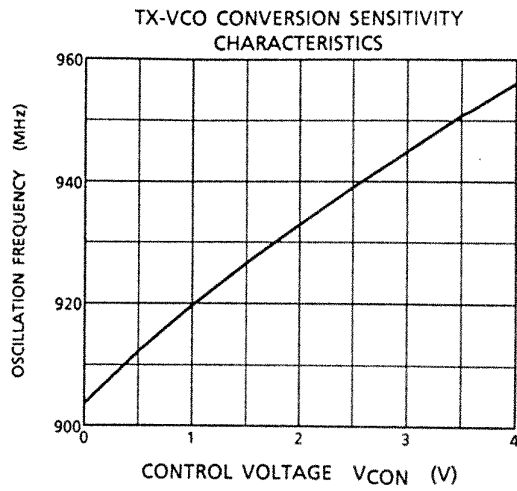
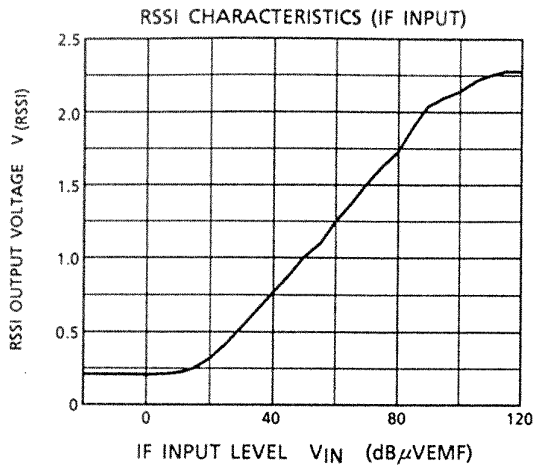

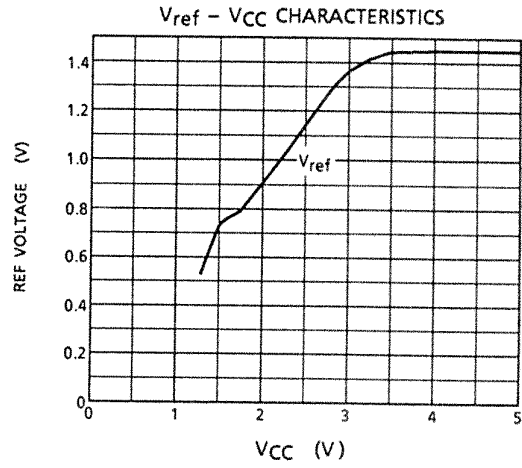
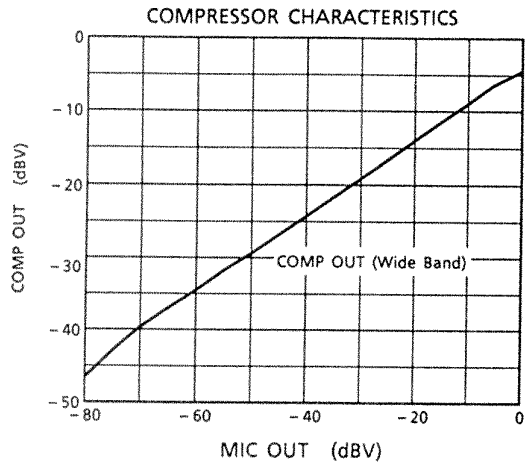
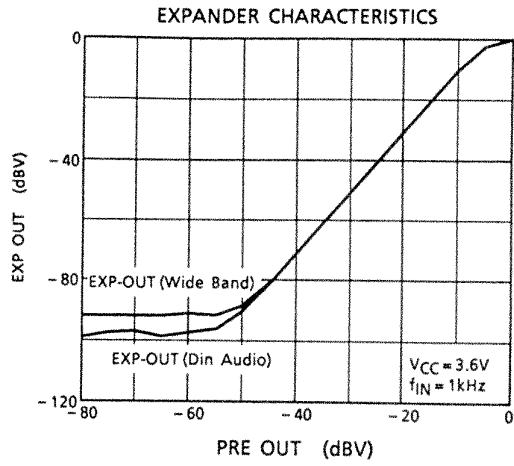
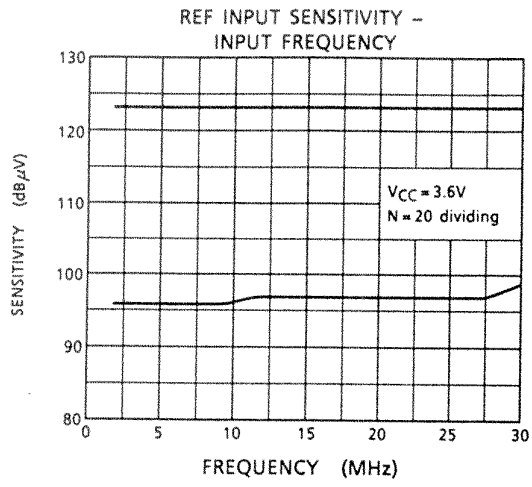

APPLICATION CIRCUIT 1

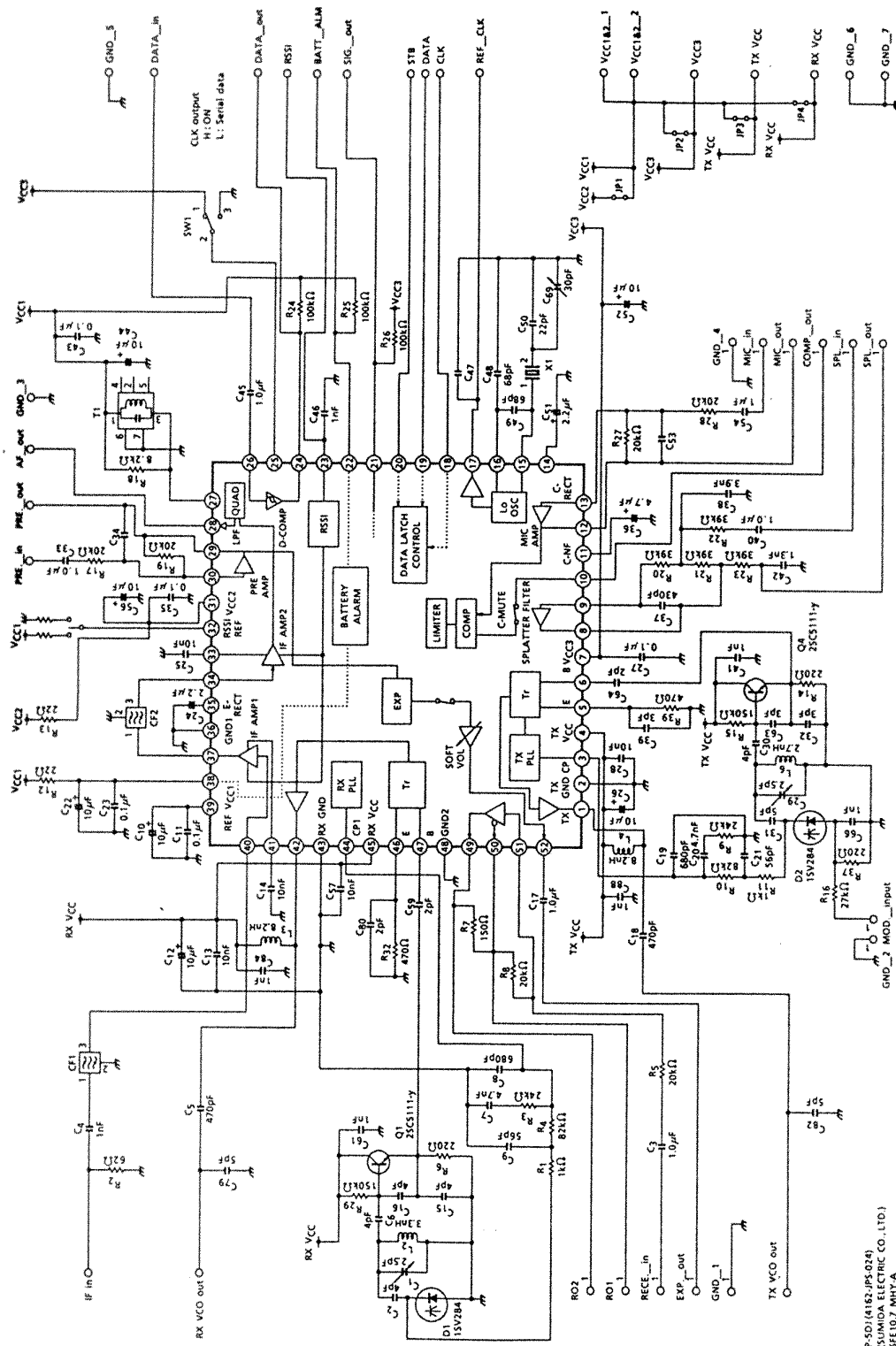

- T1 : P-30(4162-JPS-024)  
(SUMIDA ELECTRIC CO., LTD.)
- CF1, CF2 : 5F10.7 MHY-A  
(MURATA MFG. CO., LTD.)
- X1 : TR-67(NR6000)  
(TOKYO DENPA)

APPLICATION CIRCUIT 2

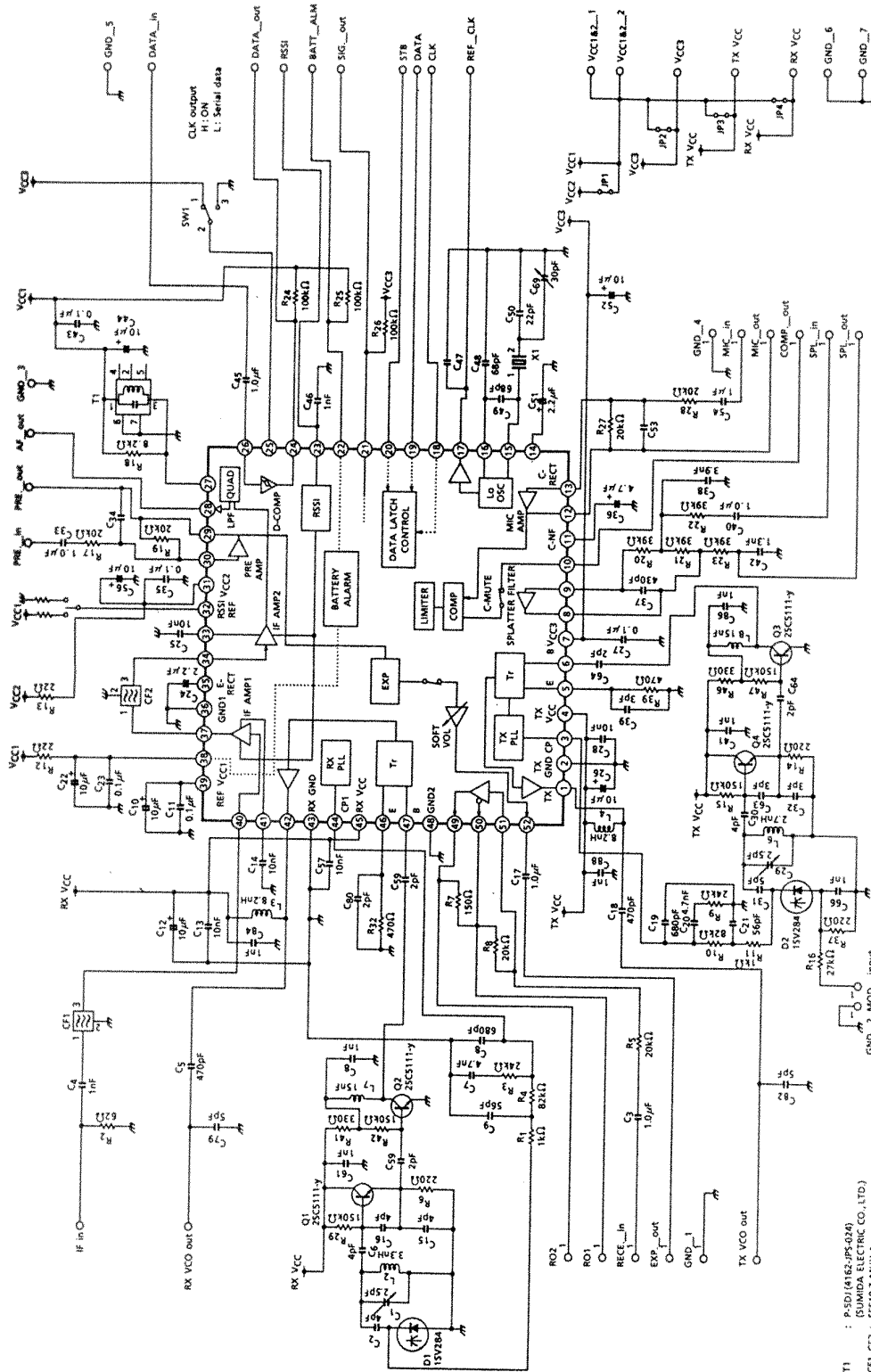

T1 : P-SD1 (4182-JPS-024)  
 (SUMIDA ELECTRIC CO., LTD.)  
 CF1, CF2 : BE10.7 MHZ-A  
 (MURATA MFG. CO., LTD.)  
 X1 : (TOKYO DENPA)



APPLICATION CIRCUIT 3

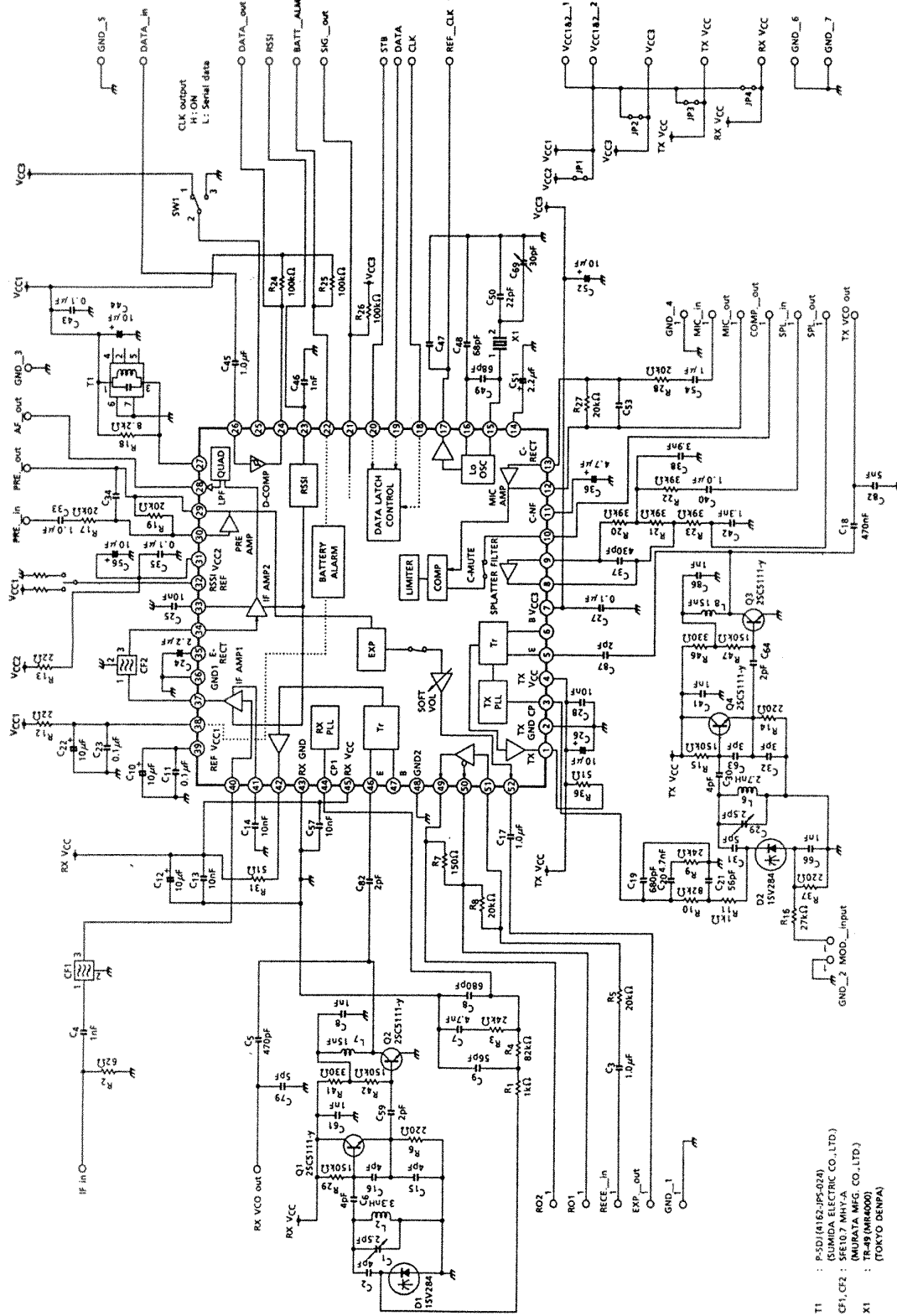

- T1 : PSDJ (R162-JPS-02A)  
(SUMIDA ELECTRIC CO., LTD.)
- CF1, CF2 : SFE10.7 MHY-A  
(MURATA MFG. CO., LTD.)
- X1 : TR-49 (MR4000)  
(TOKYO DENPA)

PACKAGE DIMENSIONS  
QFP52-P-1010-0.65

Unit : mm

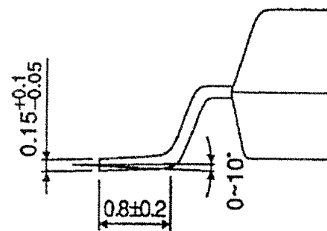
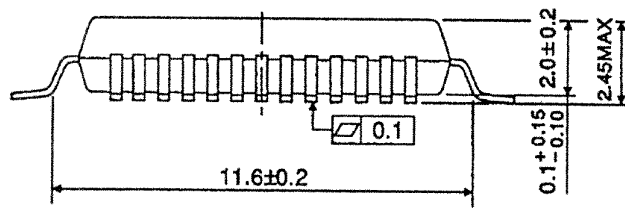
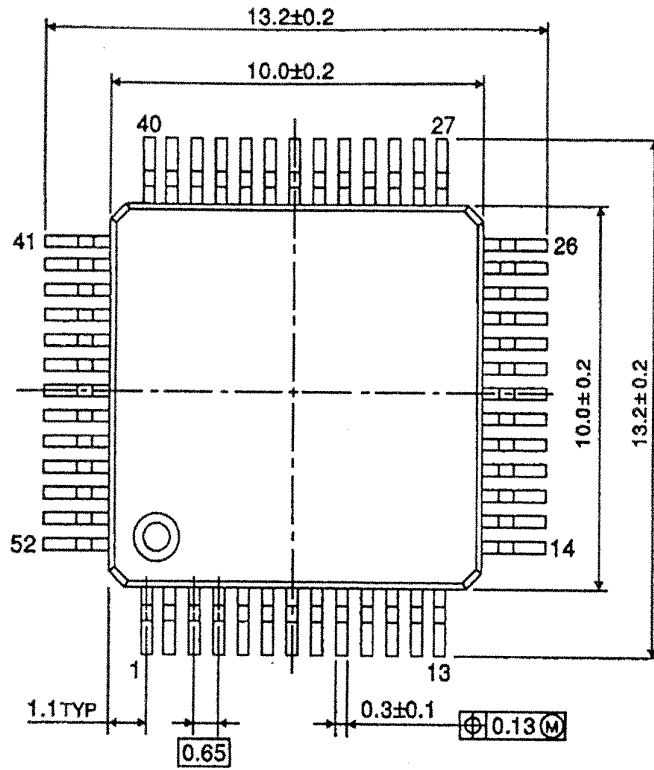

Weight : 0.45g (Typ.)