

## CONTROL CIRCUIT FOR SMPS

### GENERAL DESCRIPTION

The TDA1060 is a bipolar integrated circuit intended for the control of a switched-mode power supply. It incorporates all the control functions likely to be required in switched-mode power supplies for professional equipment.

#### Features

- Suitability for a wide range of supply voltages
- Built-in stabilized power supply for external circuitry
- Built-in temperature-compensated voltage reference
- Adjustable frequency
- Adjustable control loop sensitivity
- Adjustable pulse width
- Adjustable maximum duty factor
- Adjustable overcurrent protection limit
- Low supply voltage protection with hysteresis
- Loop fault protection
- Slow-start facility
- Feed-forward facility
- Core saturation protection facility
- Overvoltage protection facility
- Remote ON/OFF switching facility

### QUICK REFERENCE DATA

Supply voltage (voltage source)	$V_{CC}$	max.	18 V
Supply current (current source)	$I_{CC}$	max.	30 mA
Output current	$-I_{14}; I_{15}$	max.	40 mA
Stabilized voltage	$V_Z$	typ.	8,4 V
Reference voltage	$V_{ref}$	typ.	3,72 V
Output pulse repetition frequency range	$f_o$		50 Hz to 100 kHz
Operating ambient temperature range			
TDA1060; T	$T_{amb}$		-25 to + 125 °C
TDA1060A	$T_{amb}$		0 to + 70 °C
TDA1060B	$T_{amb}$		-55 to + 150 °C

### PACKAGE OUTLINES

TDA1060, TDA1060A: 16-lead DIL; plastic (SOT38).

TDA1060B: 16-lead DIL ceramic (cerdip) (SOT74).

TDA1060T: 16-lead mini-pack; plastic (SO16; SOT109A).

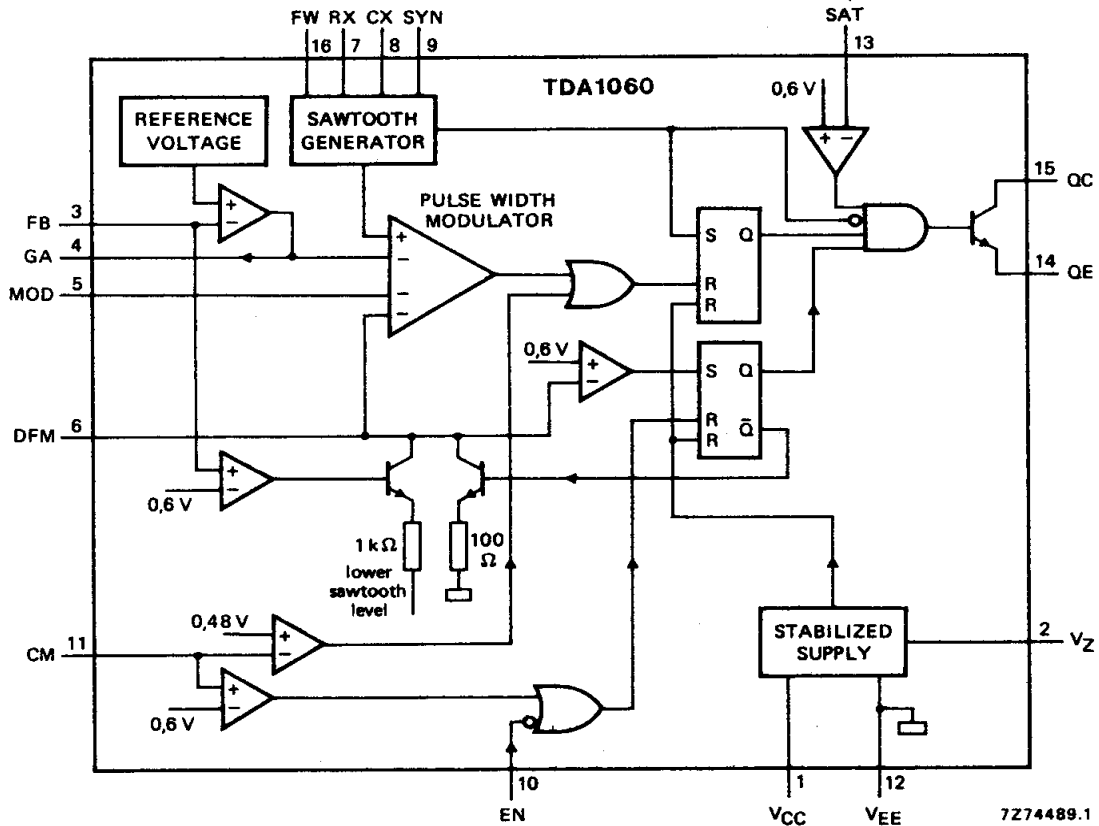

Fig. 1 Block diagram.

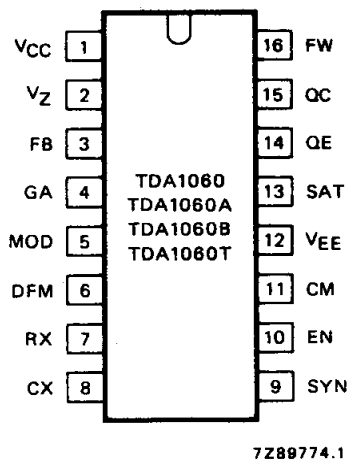

Fig. 2 Pinning diagram.

**PINNING**

- 1 VCC positive supply connection
- 2 VZ stabilized voltage output
- 3 FB feedback input
- 4 GA gain adjustment output
- 5 MOD modulation input
- 6 DFM maximum duty factor input
- 7 RX external resistor connection
- 8 CX external capacitor connection
- 9 SYN synchronization input
- 10 EN ENABLE input
- 11 CM overcurrent protection input
- 12 VEE common
- 13 SAT core saturation and overvoltage protection input
- 14 QE emitter output
- 15 QC collector output
- 16 FW feed-forward input

## FUNCTIONAL DESCRIPTION

The TDA1060 contains the control loop for a fixed-frequency pulse-duration regulated SMPS. The device works as follows. The output voltage  $V_O$  of the SMPS is sensed via a feedback network and compared with an internal reference voltage  $V_{ref}$ . Any difference between  $V_O$  and  $V_{ref}$  is amplified and fed to a pulse-width modulator (PWM), where it is compared with the instantaneous level of a ramp waveform (sawtooth) from an oscillator. The output from the PWM is a rectangular waveform synchronized with the oscillator waveform; its duty factor depends on the difference between  $V_O$  and  $V_{ref}$ . This signal drives the base of the SMPS power switching transistor so that its conduction period and hence the amount of energy transferred from the input to the output of the SMPS is controlled, resulting in a constant output voltage.

### Stabilized power supply: $V_{CC}$ and $V_Z$ (pins 1 and 2)

The circuit contains a voltage/current regulator and may be supplied either by a current source (e.g. a series resistor connected to the high voltage input of the SMPS), or a voltage source (e.g. a 12 V battery).

The stabilized voltage, typically 8,4 V, is also available at  $V_Z$ , pin 2 for supplying external circuitry, e.g. a potentiometer to adjust the maximum duty factor. This supply output is protected against short-circuits. The current drawn from this output increases the total IC supply current by the same amount.

When the supply voltage  $V_{CC}$  becomes too low, i.e.  $V_{CC} < V_Z + 0,2$  V, the circuit is automatically switched off. As soon as the supply voltage exceeds this threshold value by more than 0,2 V the circuit starts the SMPS via the slow start procedure.

### Operating frequency: RX and CX (pins 7 and 8)

The frequency of the sawtooth generator, and hence of the output pulses, is set by an external resistor R7 at RX, pin 7, and an external capacitor C8 at CX, pin 8 (see Fig. 7). The frequency may be set between 50 Hz and 100 kHz and is virtually independent of the supply voltage.

### Maximum duty factor and slow start: DFM (pin 6)

The maximum duty factor is set by the voltage on the duty factor input DFM (see Fig. 4). This voltage usually is derived from the stabilized power supply  $V_Z$ , pin 2, by an external voltage divider, see Fig. 8. As the upper and lower levels of the sawtooth waveform are set by an internal voltage divider, the accuracy of the maximum duty factor setting is determined by resistor ratios rather than by absolute values.

In case of a short-circuited feedback loop ( $V_{3-12}$  less than typ. 600 mV) the duty factor input is internally biased to the lower level of the sawtooth waveform via a resistor of typ. 1 k $\Omega$ . The maximum duty factor permitted in that case sets a maximum limit to the impedance level of the external voltage divider at pin 6.

During the flyback of the sawtooth the output pulse is inhibited. For a 1 nF capacitor C8 at pin 8 this flyback time is 1  $\mu$ s. This sets a natural limit to the duty factor.

The time constant for the slow start is determined by an external capacitor connected between the maximum duty factor input DFM and  $V_{EE}$ , pin 12, together with the impedance of the voltage divider at pin 6. This capacitor also determines the dead time before the slow start procedure for remote ON/OFF or when the current sensing voltage has exceeded 600 mV, see below.

If the DFM input is not used it should be connected to  $V_Z$  via a resistor of 5 k $\Omega$ .

**FUNCTIONAL DESCRIPTION** (continued)**Control loop sensitivity, stability, and feedback loop fault protection, FB and GA (pins 3 and 4)**

The device contains a control loop error amplifier, i.e. a differential amplifier that compares the voltage on the feedback input FB, pin 3, with the internal reference voltage. This reference voltage is a temperature-compensated voltage source based on the band-gap energy of silicon.

The control loop sensitivity is determined by the closed-loop gain  $A_f$  of the error amplifier. Normally the output from the SMPS is connected to the feedback input FB via a voltage divider and a series resistor. The closed-loop gain of the error amplifier is set by applying feedback from the gain adjustment output GA, pin 4, to the feedback input FB by a resistor R3-4, see Fig. 8.

To avoid instability a capacitor should be connected between the gain output GA and  $V_{EE}$ , pin 12. A 22 nF capacitor will cause the frequency response to fall off above 600 Hz.

The feedback input FB is internally biased to the HIGH level, this gives a protection against a feedback loop fault: an open feedback loop will make the duty factor zero.

A shorted feedback loop (feedback voltage less than typ. 600 mV) causes the maximum duty factor input DFM to be internally biased to the lower level of the sawtooth waveform via a resistor of typ. 1 k $\Omega$ , thus substantially reducing the maximum duty factor. This duty factor will then be determined by the impedance of the external voltage divider at DFM, pin 6, and the internal biasing resistor.

**Overcurrent protection input CM (pin 11)**

There are two current limits, corresponding with voltages on the overcurrent protection input CM of typ. 480 mV and 600 mV. As soon as the voltage on this input exceeds 480 mV, the running output pulse is immediately terminated; the next pulse starts normally at the next period. If the voltage exceeds 600 mV, the output pulses are inhibited for a certain dead time, during which the slow start capacitor at pin 6 is unloaded. After this the circuit starts again with the slow start procedure.

If the overcurrent protection input CM is not used, it should be connected to  $V_{EE}$ , pin 12.

**Feed-forward input FW (pin 16)**

The feed-forward input FW can be connected to an external voltage divider from the input voltage of the SMPS, see Fig. 8. It has the effect of varying the supply voltage of the sawtooth generator with respect to the stabilized voltage. When the voltage on the feed-forward input increases, the upper level of the sawtooth is also increased. Since neither the voltage level that sets the maximum duty factor nor the feedback voltage are influenced by the feed-forward, the duty factor reduces (see Fig. 6). This can therefore compensate for mains voltage variations.

If feed-forward is not required the feed-forward input FW should be connected to  $V_{EE}$ , pin 12.

**Synchronization input SYN (pin 9)**

The frequency of the sawtooth waveform, and hence of the output pulses, can be synchronized via the TTL compatible synchronization input SYN. The synchronizing frequency must be lower than the oscillator free-running frequency. When the synchronization input is LOW the sawtooth generator is stopped; it starts again when the input goes HIGH. Synchronization pulses do not influence the slope of the sawtooth, and hence not the width of the output pulses, they only change their separation in time.

For free-running operation it is advisable to connect the synchronization input SYN to  $V_Z$ , pin 2.

**Core saturation and overvoltage protection input SAT (pin 13)**

To obtain a protection against core saturation, especially during transient conditions, the output transformer of the SMPS has to be fitted with a winding serving as a current sensor. Its output voltage is rectified and fed to the SAT input.

This core saturation protection may be combined with an overvoltage protection. To this end a portion of the SMPS output voltage is also fed to the SAT input either via a voltage divider or via a suitable regulator diode (zener diode). The output pulses are inhibited as long as the voltage on this input exceeds the threshold voltage, typ. 600 mV.

The voltage at the SAT input does not influence the frequency of the sawtooth generator and hence not of the output pulses.

If none of these protection facilities are used, the SAT input should be connected to  $V_{EE}$ , pin 12.

**Remote ON/OFF switching: ENABLE input EN (pin 10)**

The output pulses can be switched on and off by applying logic levels to the TTL compatible ENABLE input. A LOW level causes immediate inhibition of the output pulses, a subsequent HIGH level switches the circuit on with the slow-start procedure.

If this facility is not required, EN should be connected to  $V_Z$ , pin 2.

**Modulation input MOD (pin 5)**

The duty factor of the output pulses may be reduced below the value resulting from the voltages on the maximum duty factor input DFM and the gain adjust output GA by applying a lower voltage to the modulation input MOD. This input may be used with an external control loop, e.g. for constant-current control, or to obtain a fold-back characteristic.

If the modulation input is not used, it should be connected to  $V_Z$ , pin 2.

**Output QC and QE (pins 13 and 14)**

To avoid double pulses that might occur at an excessively low mains voltage or an excessively high output current the output is preceded by a latch. The two outputs offer a choice of output current polarity, QC giving a positive current, i.e. a current flowing into the output, and QE giving a negative current, a current flowing out of the output. The two connections have the additional advantage that the relatively large output currents do not flow through the  $V_{CC}$  and  $V_{EE}$  connections, where they could induce noise.

**RATINGS**

Limiting values in accordance with the Absolute Maximum System (IEC 134)

Supply voltage range (voltage source)	$V_{CC}$	-0,5 to + 18 V
Supply current (current source)	$I_{CC}$	max. 30 mA
Feed-forward input voltage range		
$V_{CC} < 24$ V	$V_{16-12}$	0 to $V_{CC}$ V
$V_{CC} > 24$ V	$V_{16-12}$	0 to 24 V
Input voltage range (all other inputs)	$V_I$	0 to $V_Z$ V
Emitter output voltage range	$V_{14-12}$	0 to 5 V
Collector output voltage range	$V_{15-12}$	0 to $V_{CC}$ V
Output current		
d.c. (see Figs 3a, c and e)	$-I_{14}; I_{15}$	max. 40 mA
peak; $t = \text{max. } 1 \mu\text{s}$ ; duty factor $d < 10\%$	$-I_{14}; I_{15}$	max. 200 mA
Storage temperature range		
TDA1060; T	$T_{stg}$	-55 to + 150 °C
TDA1060A	$T_{stg}$	-55 to + 150 °C
TDA1060B	$T_{stg}$	-55 to + 150 °C
Operating ambient temperature range		
TDA1060; T	$T_{amb}$	-25 to + 125 °C
TDA1060A	$T_{amb}$	0 to + 70 °C
TDA1060B	$T_{amb}$	-55 to + 150 °C
Power dissipation (see Figs 3b, d and f)	$P_{tot}$	max. 1 W

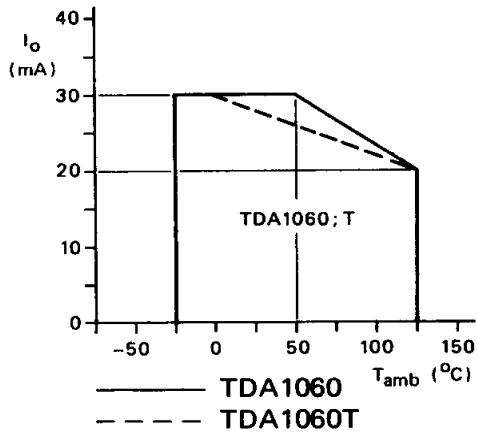

(a)

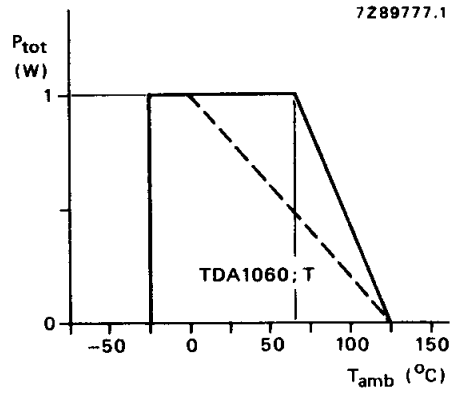

(b)

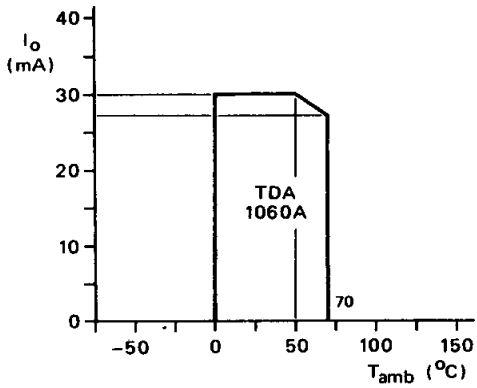

(c)

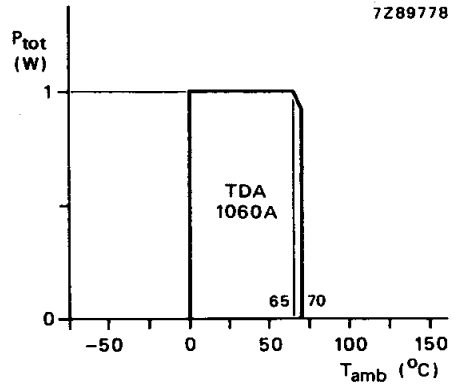

(d)

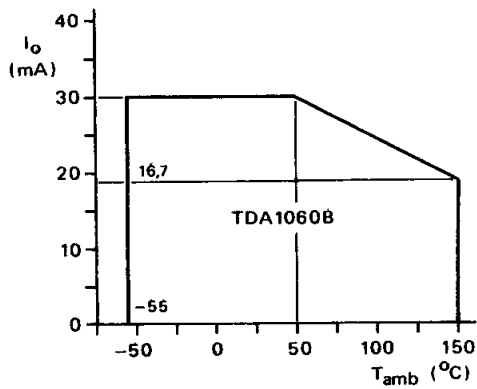

(e)

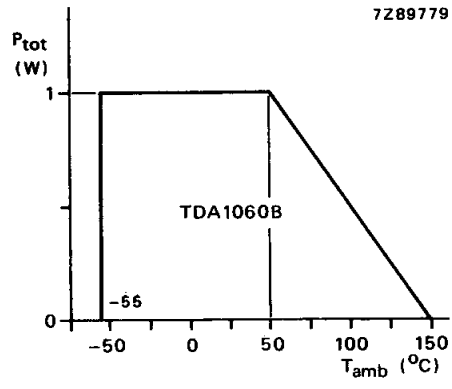

(f)

Fig. 3 Output current and power dissipation derating curves.

## CHARACTERISTICS

$V_{CC} = 12\text{ V}$ ;  $T_{amb}$  = operating ambient temperature range, unless otherwise specified.

parameter	symbol	min.	typ.	max.	unit
<b>Operating ambient temperature range</b>					
TDA1060; T	$T_{amb}$	-25	—	125	$^{\circ}\text{C}$
TDA1060A	$T_{amb}$	0	—	70	$^{\circ}\text{C}$
TDA1060B	$T_{amb}$	-55	—	150	$^{\circ}\text{C}$
<b>Supply <math>V_{CC}</math> (pin 1)</b>					
Supply voltage					
at $I_{CC} = 15\text{ mA}$					
TDA1060; T	$V_{CC}$	18,5	23	27	V
TDA1060A	$V_{CC}$	18,5	23	27	V
TDA1060B	$V_{CC}$	18	23	27,5	V
at $I_{CC} = 30\text{ mA}$					
TDA1060; T	$V_{CC}$	19,5	24	29	V
TDA1060A	$V_{CC}$	19,5	24	29	V
TDA1060B	$V_{CC}$	19	24	29,5	V
Supply current; $R7 = 25\text{ k}\Omega$ ; duty factor $\delta = 50\%$ ; $I_Z = 0$ ; at $T_{amb} = 25\text{ }^{\circ}\text{C}$					
over ambient temperature range	$I_{CC}$	2,5	—	10	mA
	$I_{CC}$	2,5	—	15	mA
Threshold voltage of low supply voltage protection at $T_{amb} = 25\text{ }^{\circ}\text{C}$					
	$V_{CC}$	8,85	—	10,8	V
Variation with temperature					
	$-\Delta V_{CC}/\Delta T$	—	7,5	—	mV/K
Hysteresis of low supply voltage protection					
	$\Delta V_{CC}$	—	500	—	mV
<b>Stabilized supply output <math>V_Z</math> (pin 2)</b>					
Output voltage at $T_{amb} = 25\text{ }^{\circ}\text{C}$					
	$V_Z$	7,5	8,4	9	V
Variation with temperature					
	$\Delta V_Z/\Delta T$	-1,5	—	+1,5	mV/K
Output current					
	$-I_Z$	—	—	5	mA
<b>Feedback input FB (pin 3)</b>					
Input voltage, feedback operation					
	$V_{3-12}$	2	—	$V_Z - 1$	V
Input current at $V_{3-12} = 2\text{ V}$					
	$-I_3$	1,5	12	35	$\mu\text{A}$
Internal reference voltage, measured at pin 3; pins 3 and 4 interconnected and grounded via a 100 nF capacitor; $T_{amb} = 25\text{ }^{\circ}\text{C}$					
	$V_{ref}$	3,42	3,72	4,03	V
Variation with temperature					
	$\frac{\Delta V_{ref}/V_{ref}}{\Delta T}$	—	0,01	—	%/K
Variation with supply voltage					
	$\frac{\Delta V_{ref}}{\Delta V_{CC}}$	—	0,8	—	mV/V



parameter	symbol	min.	typ.	max.	unit
Long-term variation with time	$\pm \Delta V_{ref}/\Delta t$	—	2	—	$\mu\text{V}/\text{h}$
Threshold voltage of feedback loop short-circuit protection at $T_{amb} = 25^\circ\text{C}$	$V_{3-12}$	470	600	720	mV
Variation with temperature	$\frac{\Delta V_{3-12}/V_{3-12}}{\Delta T}$	—	0,01	—	%/K
<b>Gain adjustment output GA (pin 4)</b>					
Open-loop gain, pin 3 to pin 4	$A_o$	—	60	—	dB
External feedback resistance	$R_{3-4}$	10	—	—	k $\Omega$
<b>Modulator input MOD (pin 5)</b>					
Input current at $V_{5-12} = 2\text{ V}$ ; $V_{4;6-12} > 2\text{ V}$	$-I_5$	—	—	5	$\mu\text{A}$
<b>Maximum duty factor input DFM (pin 6)</b>					
Input voltage for limiting the duty factor to 50%; $f_o = 20$ to $50\text{ kHz}$ ; $V_{16-12} = 0\text{ V}$	$V_{6-12}$	—	$0,42V_Z$	—	V
Input current at $V_{6-12} = 2\text{ V}$	$-I_6$	—	—	6	$\mu\text{A}$
Capacitor discharge current during fault condition	$I_6$	2,5	—	—	mA
Minimum output OFF time at $C7 = 1,8\text{ nF}$	$t_{off}$	—	1	—	$\mu\text{s}$
Variation of max. duty factor with tempera- ture at $f_o = 20\text{ kHz}$ and $\delta_{max} = 50\%$	$\Delta\delta_{max}/\Delta T$	—	0,02	—	%/K
Internal biasing resistor to $V_{EE}$ at $V_{3-12} = 0\text{ V}$	$R_{6-12}$	0,75	1	1,25	k $\Omega$
<b>Synchronization input SYN (pin 9)</b>					
Input voltage, sawtooth ON	$V_{IH}$	2	—	$V_Z$	V
sawtooth OFF: TDA1060; TDA1060A; TDA1060T	$V_{IL}$	0	—	0,8	V
TDA1060B	$V_{IL}$	0	—	0,6	V
Input current at $V_{9-12} = 0\text{ V}$	$-I_{IL}$	20	—	120	$\mu\text{A}$
<b>External resistor connection RX (pin 7)</b>					
External frequency adjustment resistor	$R_7$	5	—	40	k $\Omega$
<b>External capacitor connection CX (pin 8)</b>					
Sawtooth, upper level at $V_{16-12} = 0\text{ V}$	$V_{8-12}$	—	5,7	—	V
lower level	$V_{8-12}$	—	1,3	—	V
Oscillator frequency $R_7 = 6,4\text{ k}\Omega$ , $C_8 = 6,4\text{ nF}$	$f_{osc}$	—	30,5	—	kHz
Output pulse repetition frequency range	$f_o$	0,05	—	100	kHz
Variation with temperature	$\frac{\Delta f_o/f_o}{\Delta T}$	—	0,03	—	%/K

## CHARACTERISTICS (continued)

parameter	symbol	min.	typ.	max.	unit
<b>Feed-forward input FW (pin 16)</b>					
Input voltage for $V_{CC} < 24$ V	$V_{16-12}$	0	—	$V_{CC}$	V
for $V_{CC} > 24$ V	$V_{16-12}$	0	—	24	V
Input current at $V_{16-12} = 16$ V; $V_{CC} = 18$ V; $T_{amb} = 25$ °C	$I_{16}$	—	—	5	$\mu$ A
Frequency variation with input voltage at $V_{16-12} > 8$ V	$\frac{\Delta f_o/f_o}{\Delta V_{16-12}}$	—	1	—	%/V
<b>Overcurrent protection input CM (pin 11)</b>					
Input voltage	$V_{11-12}$	0	—	$V_Z$	V
Input threshold voltage for single pulse inhibit (current limit mode); $T_{amb} = 25$ °C	$V_{T1}$	400	—	500	mV
Ratio of threshold voltages for shot down/ slow start and for single pulse inhibit	$V_{T2}/V_{T1}$	—	1,25	—	
Threshold variation with temperature	$\Delta V/\Delta T$	—	125	—	$\mu$ V/K
Input current at $V_{11-12} = 250$ mV	$-I_{11}$	—	—	10	$\mu$ A
Turn-off delay, $I_{15} = 40$ mA; $V_{11-12} = 1,2 \times V_{T1}$	$t_d$	—	—	1,0	$\mu$ s
<b>Core saturation and overvoltage protection input SAT (pin 13)</b>					
Input voltage	$V_{13-12}$	0	—	$V_Z$	V
Input threshold voltage at $T_{amb} = 25$ °C	$V_{13-12}$	470	600	720	mV
Threshold variation with temperature	$\Delta V/\Delta T$	—	125	—	$\mu$ V/K
Input current at $V_{13-12} = 250$ mV	$-I_{13}$	—	—	7	$\mu$ A
<b>ENABLE input EN (pin 10)</b>					
Input voltage ON	$V_{IN}$	2	—	$V_Z$	V
OFF: TDA1060; TDA1060A; TDA1060T	$V_{IL}$	0	—	0,8	V
TDA1060B	$V_{IL}$	0	—	0,6	V
Input current at $V_{10-12} = 0$ V	$-I_{IL}$	20	—	120	$\mu$ A
<b>Outputs QC and QE (pins 14 and 15)</b>					
Output current	$-I_{14}; I_{15}$	40	—	—	mA
Emitter output voltage	$V_{14-12}$	—	—	5	V
Collector output voltage at $V_{14-12} = 0$ V; $I_{15} = 40$ mA	$V_{15-14}$	—	—	500	mV

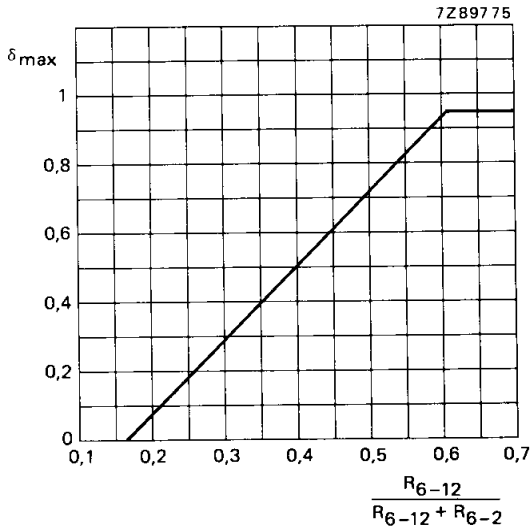

Fig. 4 Maximum duty factor  $\delta_{max}$  as a function of the voltage divider ratio at the duty factor input DFM.

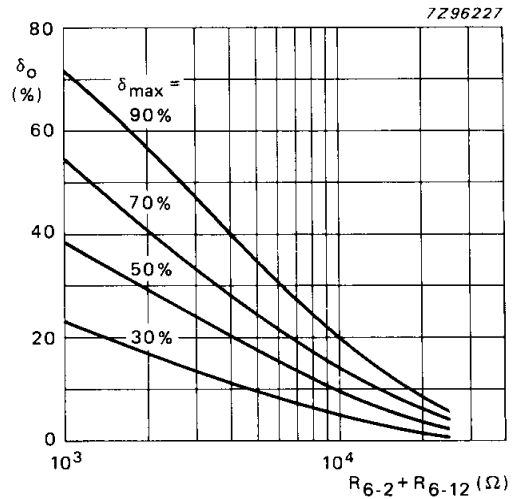

Fig. 5 Soft-start minimum duty factor ( $\delta_0$ ) as a function of  $R_{6-2}$  and  $R_{6-12}$ .

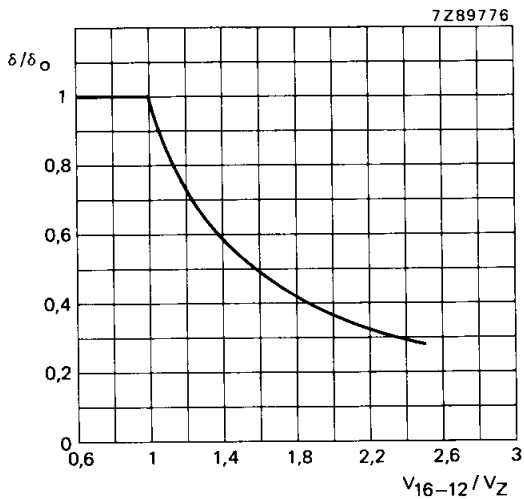

Fig. 6 Feed-forward regulation characteristic. Duty factor  $\delta$  as a function of the voltage  $V_{16-12}$  on the feed-forward input FW.  $\delta_0$  is the duty factor for  $V_{16-12} \leq V_Z$ .

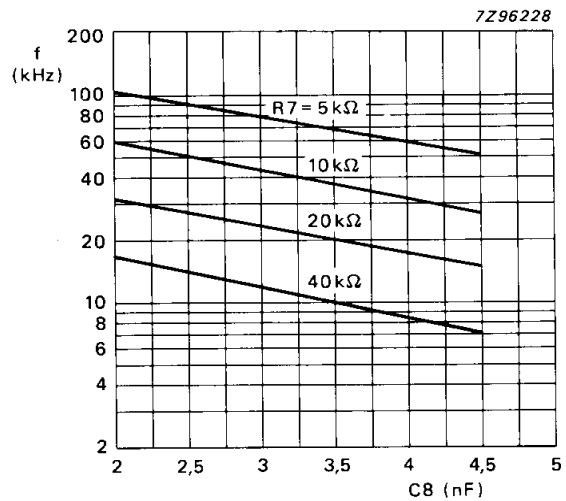

Fig. 7 Typical frequency as a function of  $C_8$  ( $R_7$  as parameter).

APPLICATION INFORMATION

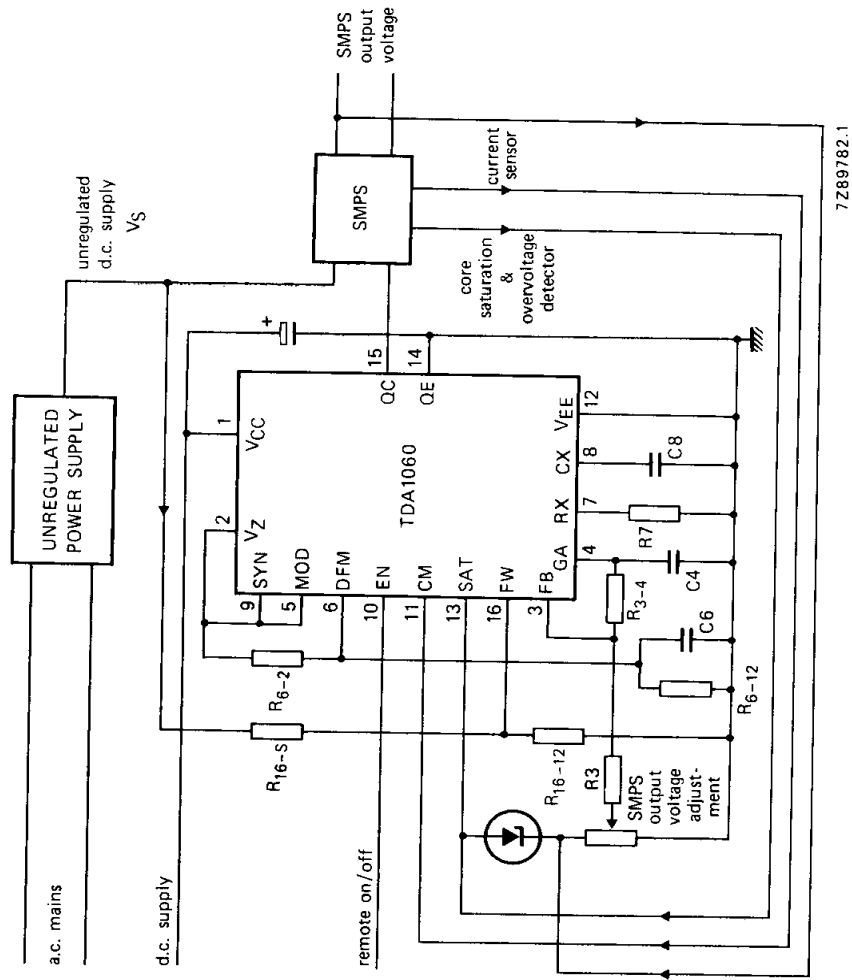
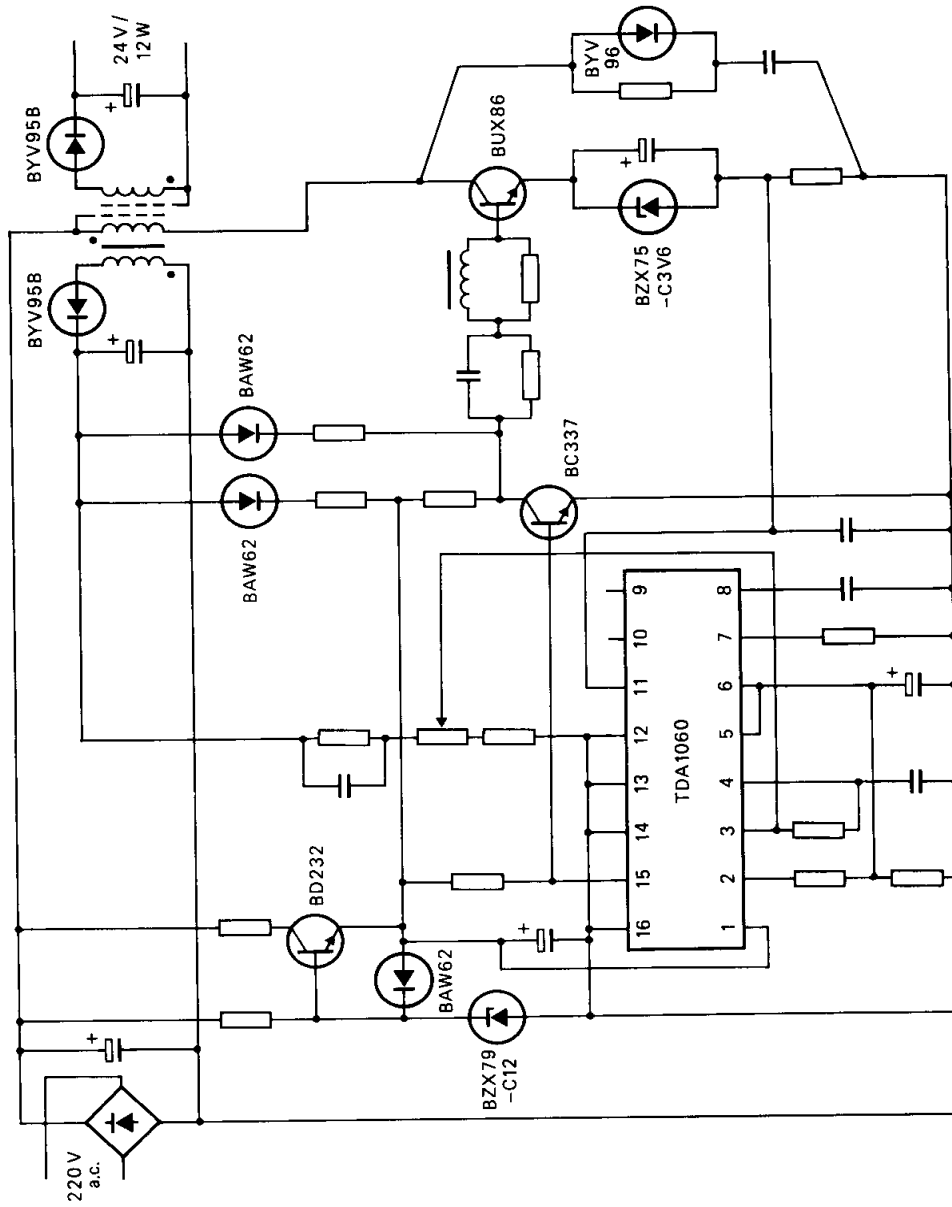
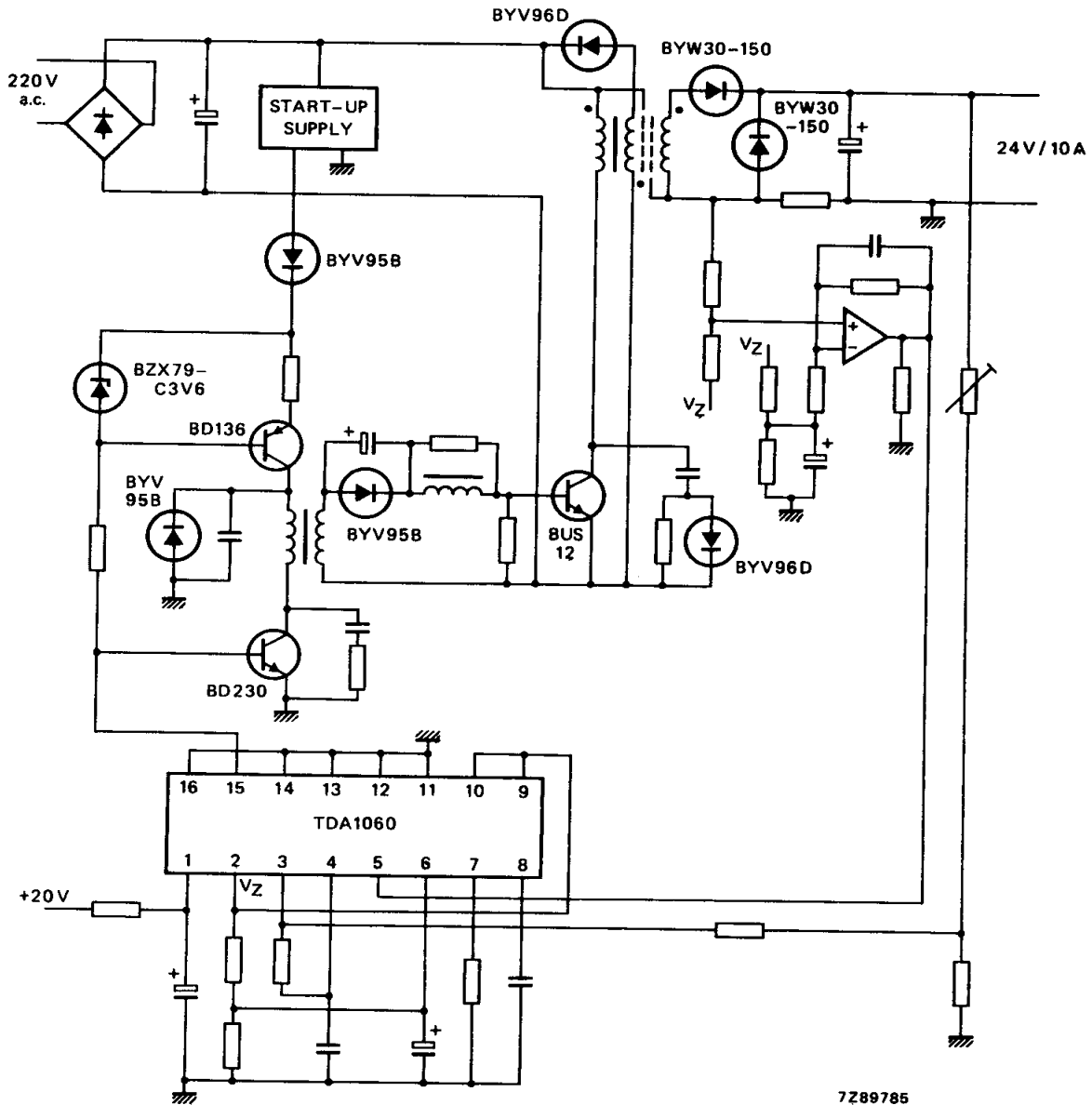

Fig. 8 Connections to the TDA1060 in a switched-mode power supply.



7Z89784

Fig. 9 Application of the TDA1060 in a 24 V, 12 W SMPS with flyback converter.



7289785

Fig. 10 Application of the TDA1060 in a 24 V, 240 W SMPS with forward converter.

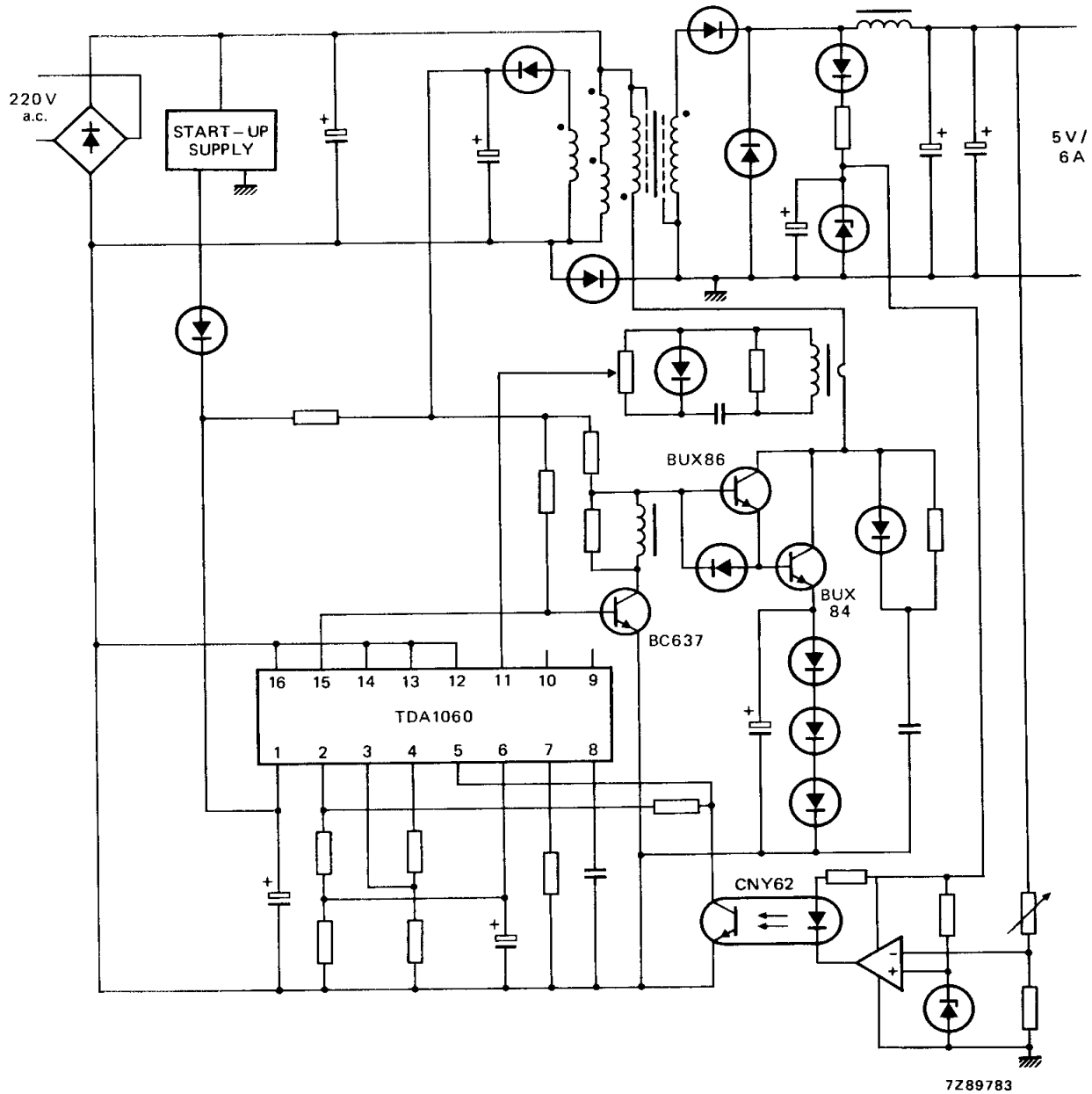

Fig. 11 Application of the TDA1060 in a 5 V, 30 W SMPS with forward converter and with an optocoupler CNY62 for voltage separation.

APPLICATION INFORMATION SUPPLIED UPON REQUEST.