

### Data Sheet

#### Description

The  $\mu$ PD75116(A) is one of the 4-bit single-chip micro-computer 75X series.

The  $\mu$ PD75116(A) is a product with the extended ROM capacity of the  $\mu$ PD75108(A). In addition of high-speed operations, it can manipulate data in units of 1, 4 and 8 bits. In particular, the I/O operation of the  $\mu$ PD75116 have been improved by a wide variety of bit control instructions. The  $\mu$ PD75116 is provided with interface inputs/outputs with peripheral circuits having different power voltages, and analog inputs and suitable for controlling automobile electrical equipment, etc. For the  $\mu$ PD75116(A), an on-chip pin-compatible one-time PROM product ( $\mu$ PD75P116) is separately available for system development evaluation.

**Functions are described in detail in the following User's Manual, which should be read when carrying out design work.**

$\mu$ PD751 $\times$  Series User's Manual: IEM-992

#### Features

- Higher reliability than  $\mu$ PD75116
- Architecture "75X" equivalent to 8-bit microcomputer
- Minimum instruction execution time (high-speed operation): 0.95  $\mu$ s (when operated at 4.19 MHz and 5 V)
- Instruction execution variable function: 0.95 $\mu$ s/1.91 $\mu$ s/15.3  $\mu$ s (when operated at 4.19 MHz)
- Many input/output ports: 58
- 3-channel on-chip 8-bit timers
- 8-bit on-chip serial interface
- Multi-interruptible vector interrupt function

#### Applications

Automobile electrical equipment, etc.

Ordering Code	Package	Quality Grade
$\mu$ PD75112CW(A)- $\times$ $\times$ $\times$	64-pin plastic shrink DIP (750 mil)	Special
$\mu$ PD75112GF(A)- $\times$ $\times$ $\times$ -3BE	64-pin plastic QFP (14 $\times$ 20 mm)	Special
$\mu$ PD75116CW(A)- $\times$ $\times$ $\times$	64-pin plastic shrink DIP (750 mil)	Special
$\mu$ PD75116GF(A)- $\times$ $\times$ $\times$ -3BE	64-pin plastic QFP (14 $\times$ 20 mm)	Special

**Remarks:**  $\times$  $\times$  $\times$  is a ROM code number.

Please refer to "Quality Grade on NEC Semiconductor Devices" (Document number IEI-1209) published by NEC Corporation to know the specification of quality grade on the devices and its recommended applications.

**Unless there are any particular functional differences, the  $\mu$ PD75116(A) is described in this document as a representative product.**

The information in this document is subject to change without notice.

The mark ★ shows major revised points.

## $\mu$ PD75112(A), 75116(A)

### Differences between $\mu$ PD75112(A), 75116(A) and $\mu$ PD75112, 75116

Item		Product Name	
		$\mu$ PD75112(A), 75116(A)	$\mu$ PD75112, 75116
Quality grade		Special	Standard
Electrical specifications	Absolute maximum ratings	Different high-level output current and low-level output current	
	DC characteristics	Different low-level output voltage	
Direct LED drive		Not possible	Possible

### Outline of Functions

Item	Description	
No. of basic instruction	43	
Min. instruction execution time	0.95 $\mu$ s/1.91 $\mu$ s/15.3 $\mu$ s (when operated at 4.19 MHz), switchable at 3 levels	
On-chip memory	ROM	12160 $\times$ 8 ( $\mu$ PD75112(A)), 16256 $\times$ 8 ( $\mu$ PD75116(A))
	RAM	512 $\times$ 4
General register	4 bits $\times$ 8 $\times$ 4 banks (memory mapping)	
Accumulator	Three accumulated in compliance with controlled data lengths <ul style="list-style-type: none"> <li>• 1-bit accumulator (CY), 4-bit accumulator (A), 8-bit accumulator (XA)</li> </ul>	
Input/output port	58 in total <ul style="list-style-type: none"> <li>• CMOS input pin : 10</li> <li>• CMOS input/output pin (LED direct drive enable) : 32</li> <li>• Intermediate withstand voltage N-ch open drain input/output pin (bit-wise pull-up resistor incorporation possible) : 12</li> <li>• Comparator input pin (4-bit accuracy) : 4</li> </ul>	
Timer/counter	<ul style="list-style-type: none"> <li>• 8-bit timer/event counter <math>\times</math> 2</li> <li>• 8-bit basic interval timer (applicable to watchdog timer)</li> </ul>	
Serial interface	<ul style="list-style-type: none"> <li>• 8-bits</li> <li>• First LSB/first MSB switchable</li> <li>• Two transfer modes (transmit and receiver/receive dedicated mode)</li> </ul>	
Vector interrupt	External : 3, Internal : 4	
Test input	External : 2	
Standby	<ul style="list-style-type: none"> <li>• STOP/HALT mode</li> </ul>	
Operating temperature range	-40 to +85°C	
Operating voltage	2.7 to 6.0 V	
Others	<ul style="list-style-type: none"> <li>• On-chip power-on reset circuit (mask option)</li> <li>• On-chip bit control memory (bit sequential buffer)</li> </ul>	
Package	<ul style="list-style-type: none"> <li>• 64-pin plastic shrink DIP (750 mil)</li> <li>• 64-pin plastic QFP (14 <math>\times</math> 20 mm)</li> </ul>	

## CONTENTS

1. Pin Configuration (Top View).....	4
2. Block Diagram.....	6
3. Pin Functions.....	7
3.1 Port Pins.....	7
3.2 Non-Port Pins.....	8
3.3 Pin Input/Output Circuits.....	9
3.4 Recommended Connection of Unused Pins.....	10
3.5 Caution Relating to Use of P00/INT4 Pin and $\overline{\text{RESET}}$ Pin.....	10
4. Memory Configuration.....	11
5. Peripheral Hardware Functions.....	14
5.1 Digital Input/Output Port.....	14
5.2 Clock Generator.....	14
5.3 Clock Output Circuit.....	16
5.4 Basic Interval Timer.....	16
5.5 Timer/Event Counter.....	17
5.6 Serial Interface.....	19
5.7 Programmable Threshold Port (Analog Input Port).....	21
5.8 Bit Sequential Buffer.....	22
5.9 Power-On Flag (Mask Option).....	22
6. Interrupt Functions.....	23
7. Standby Functions .....	25
8. Reset Functions.....	26
9. Instruction Set.....	29
10. Mask Option Selection.....	37
11. Electrical Specifications.....	38
12. Package Information .....	48
13. Recommended Soldering Conditions .....	51
APPENDIX A. Differences between $\mu$ PD751 $\times\times$ (A) Series Products and Related PROM Products.....	52
APPENDIX B. Development Tools .....	53
APPENDIX C. Related Documentations .....	54

## $\mu$ PD75112(A), 75116(A)

### 1. Pin Configuration (Top View)

64-Pin Plastic Shrink DIP (750 mil)

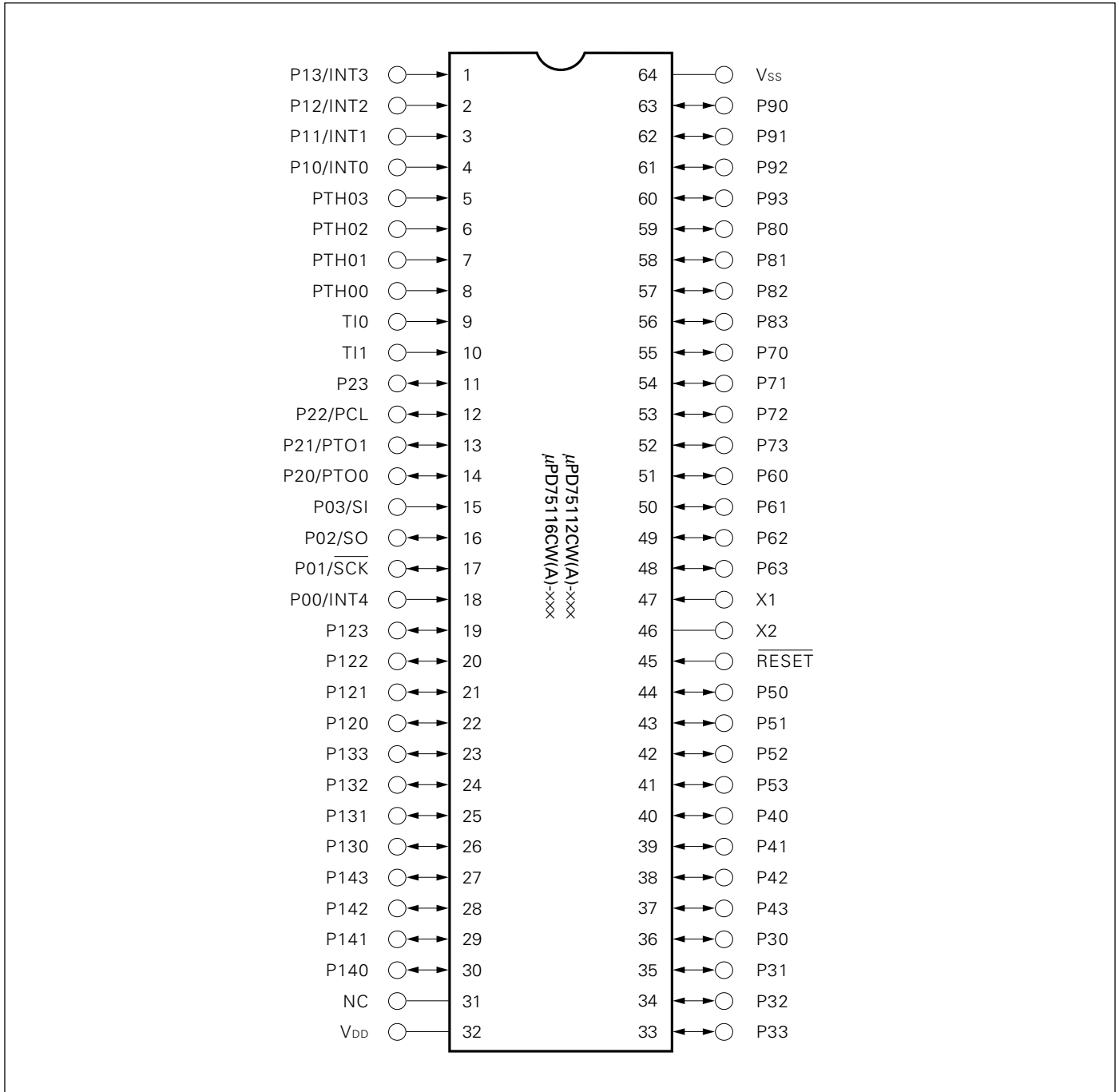

### 64-Pin Plastic QFP (14 × 20 mm)

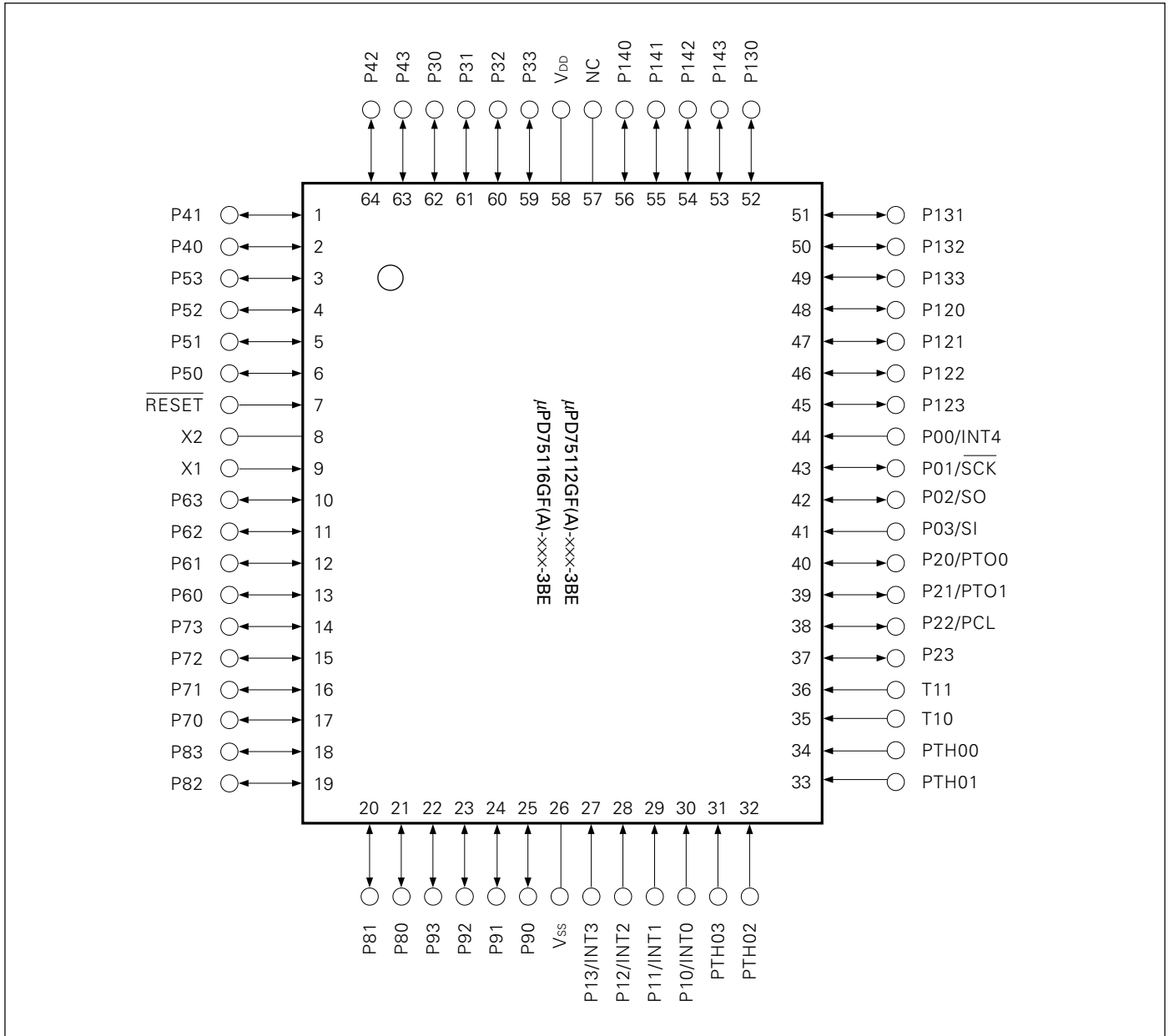

#### Pin Name ★

P00-P03	: Port0	$\overline{SCK}$	: Serial Clock
P10-P13	: Port1	SO	: Serial Output
P20-P23	: Port2	SI	: Serial Input
P30-P33	: Port3	PTO0, PTO1	: Programmable Timer Output
P40-P43	: Port4	PCL	: Programmable Clock
P50-P53	: Port5	PTH00-PTH03	: Programmable Threshold Input
P60-P63	: Port6	INT0, INT1, INT4	: External Vectored Interrupt Input
P70-P73	: Port7	INT2, INT3	: External Test Input
P80-P83	: Port8	TI0, TI1	: Timer Input
P90-P93	: Port9	X1, X2	: Clock Oscillation
P120-P123	: Port12	RESET	: Reset
P130-P133	: Port13	NC	: No Connection
P140-P143	: Port14	V <sub>DD</sub>	: Positive Power Supply
		V <sub>SS</sub>	: Ground

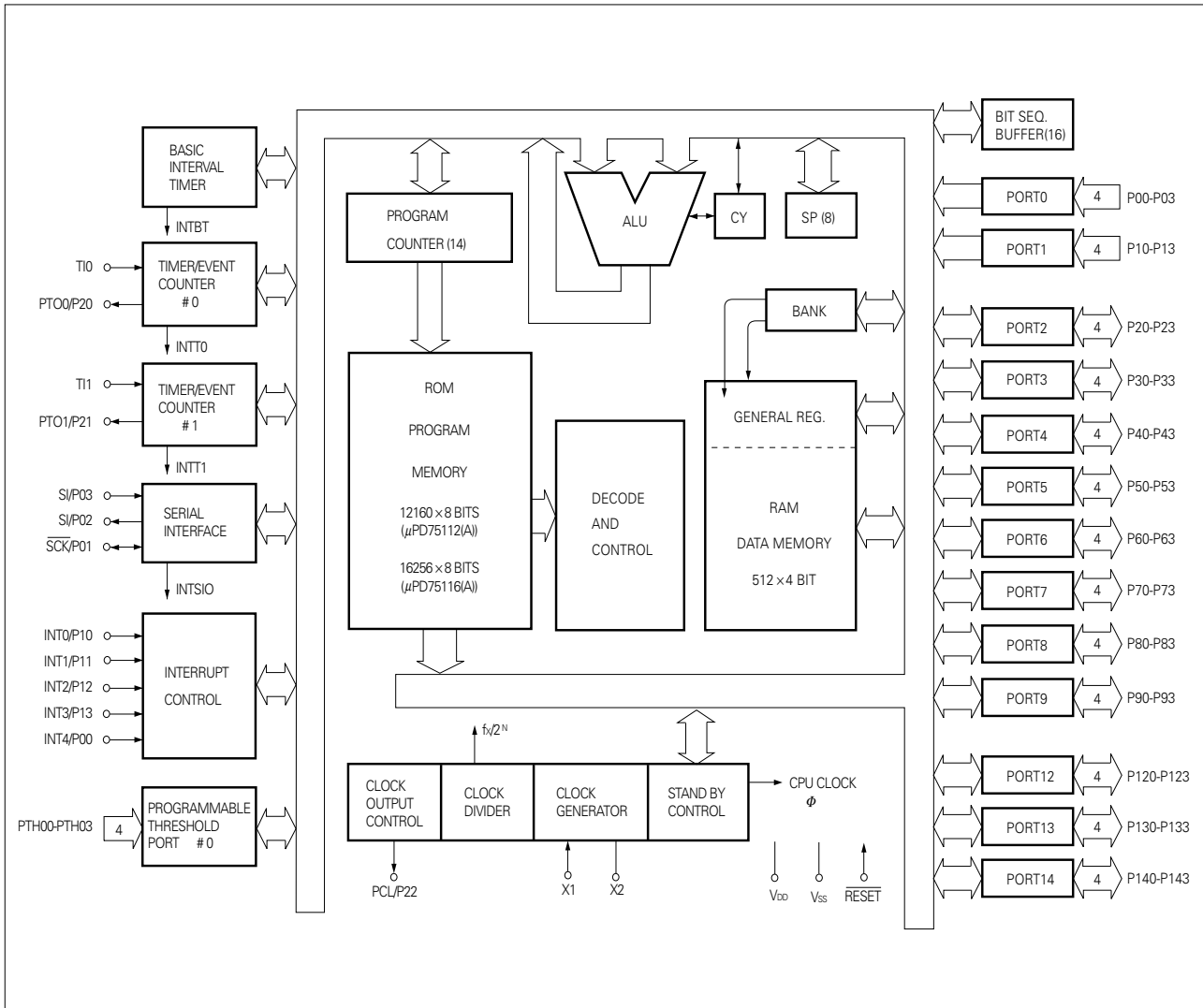

2. Block Diagram

$\mu$ PD75112(A), 75116(A)



### 3. Pin Functions

#### 3.1 Port Pins

Pin Name	Input/ Output	Dual Function Pin	Function	8-Bit I/O	At Reset	I/O Circuit Type *1
P00	Input	INT4	4-bit input port (PORT0)	×	Input	ⓑ
P01	Input/output	$\overline{\text{SCK}}$				ⓕ
P02	Input/output	SO				E
P03	Input	SI				ⓑ
P10	Input	INT0	4-bit input port (PORT1)		Input	ⓑ
P11		INT1				
P12		INT2				
P13		INT3				
P20	Input/output	PTO0	4-bit input/output port (PORT2)	×	Input	E
P21		PTO1				
P22		PCL				
P23		—				
P30 to P33	Input/output	—	Programmable 4-bit input/output port (PORT3) Bit-wise input/output setting enable		Input	E
P40 to P43	Input/output	—	4-bit input/output port (PORT4)	○	Input	E
P50 to P53	Input/output	—	4-bit input/output port (PORT5)		Input	E
P60 to P63	Input/output	—	Programmable 4-bit input/output port (PORT6) Bit-wise input/output setting enable	○	Input	E
P70 to P73	Input/output	—	4-bit input/output port (PORT7)		Input	E
P80 to P83	Input/output	—	4-bit input/output port (PORT8)	○	Input	E
P90 to P93	Input/output	—	4-bit input/output port (PORT9)		Input	E
P120 to P123	Input/output	—	N-ch open drain 4-bit input/ output port (PORT12) Bit-wise pull-up resistor incorporation enable (mask option) 2 V withstand for open drain	○	Input*2	M
P130 to P133	Input/output	—	N-ch open drain 4-bit input/ output port (PORT13) Bit-wise pull-up resistor incorporation enable (mask option) 12 V withstand for open drain		Input*2	M
P140 to P143	Input/output	—	N-ch open drain 4-bit input/output port (PORT14) Bit-wise pull-up resistor incorporation enable (mask option) 12 V withstand for open drain	—	Input*2	M

\* 1: Circles indicate Schmitt trigger inputs.

2: High impedance for open drain  
High level for on-chip pull-up resistors

## μPD75112(A), 75116(A)

### 3.2 Non-Port Pins

	Input/Output	Dual Function Pin	Function	At Reset	I/O Circuit Type*1
PTH00 to PTH03	Input	—	Threshold voltage ariable 4-bit analogy input port.		N
TI0	Input	—	External event pulse input for the timer/event counter or edge detect vector interrupt input. 1-bit input enable.		(B)
TI1					
PTO0	Input/output	P20	Timer/event counter output.	Input	E
PTO1		P21			
$\overline{\text{SCK}}$	Input/output	P01	Serial clock input/output.	Input	(F)
SO	Input/output	P02	Serial data output.	Input	E
SI	Input	P03	Serial data input.	Input	(B)
INT4	Input	P00	Edge detect vector interrupt input (for detecting both rising and falling edges).	Input	(B)
INT0	Input	P10	Edge detect vector interrupt input (detected edge selectable).	Input	(B)
INT1		P11			
INT2	Input	P12	Edge detect testable input (for rising edge detection).	Input	(B)
INT3		P13			
PCL	Input/output	P22	Clock output.	Input	E
X1, X2		—	Crystal/ceramic connect pin (system clock oscillation). In case with the external clock, input a signal to X1 and the antiphase to X2.		
$\overline{\text{RESET}}$	Input	—	System reset input (low level active).		(B)
NC*2	—	—	No Connection		
V <sub>DD</sub>		—	Positive power supply.		
V <sub>SS</sub>		—	GND potential.		

\* 1: Circles indicate Schmitt trigger inputs.

2: When the PWB is shared with the μPD75P116, connect the NC pin to V<sub>DD</sub> directly.



### 3.3 Pin Input/Output Circuits

$\mu$ PD75116(A) pin input/output circuit are shown in schematic form.

**Figure 3-1 Pin Input/Output Circuits**

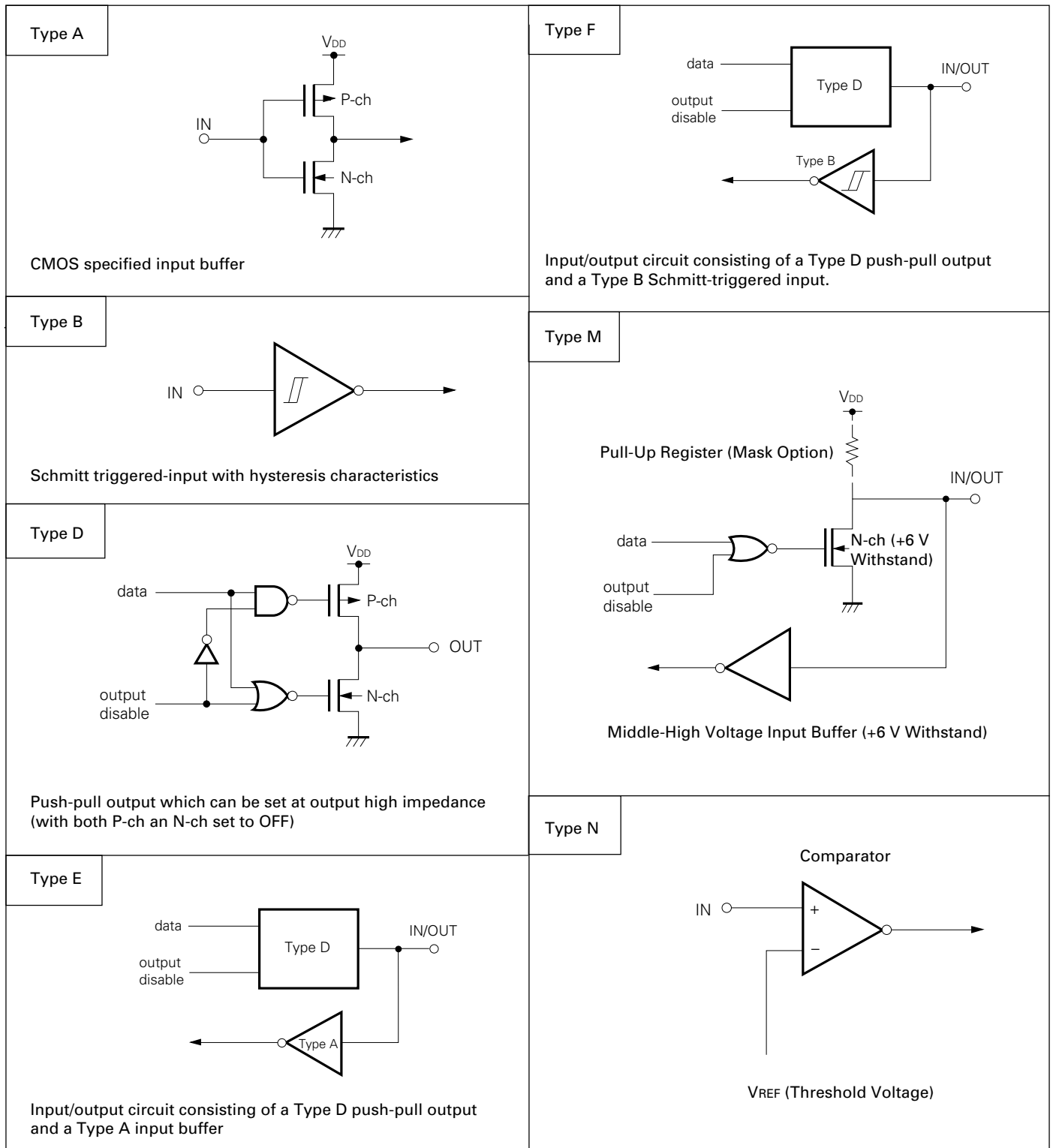

## $\mu$ PD75112(A), 75116(A)

### 3.4 Recommended Connection of Unused Pins

Pin	Recommended Connecting Method	
PTH00 to PTH03	Connect to Vss or VDD	
T10		
T11		
P00	Connect to Vss	
P01 to P03	Connect to Vss or VDD	
P10 to P13	Connect to Vss	
P20 to P23	Input state : Connect to Vss or VDD Output state : Leave open	
P30 to P33		
P40 to P43		
P50 to P53		
P60 to P63		
P70 to P73		
P80 to P83		
P90 to P93		
P120 to P123		
P130 to P133		
P140 to P143		
RESET		Connect to VDD*1
NC		Leave open or connect to VDD*2

\*1: Only when a power-on reset generator is built in by mask option, connect to VDD.

\*2: When the PWB is shared with the  $\mu$ PD75P116, connect the NC pin to VDD directly.

### 3.5 Caution Relating to Use of P00/INT4 Pin and RESET Pin

In addition to the functions described in sections 3.1 and 3.2, the P00/INT4 pin and the RESET pin have the function to set the IC test mode for testing the  $\mu$ PD75116(A) internal operations.

When a voltage larger than VDD is applied to one of these two pins, the test mode is set. Thus, if noise exceeding VDD is applied even during normal operations, the test mode is set and normal operations may be discontinued.

For example, if a cable from the P00/INT4 or RESET pin is too long, inter-wiring noise may be applied to the pin, the pin voltage may become larger than VDD, causing malfunctioning.

Thus, carry out wiring to minimize inter-wiring noise. If the noise cannot be suppressed completely, carry out the following countermeasure against noise using an externally mounted component.

o Connect a diode with low  $V_F$  (max 0.3 V) between VDDs

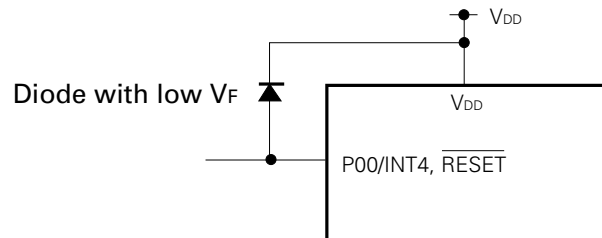

o Connect a capacitor between VDDs

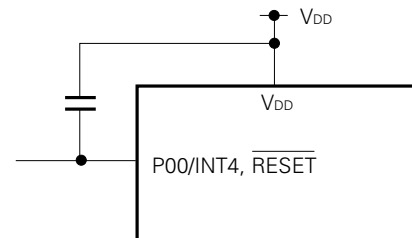

### 4. Memory Configuration

- Program Memory (ROM)
  - 12160 × 8 bits (0000H to 2F7FH): μPD75112(A)
  - 16256 × 8 bits (0000H to 3F7FH): μPD75116(A)
  - 0000H to 0001H: Vector table for writing the program start address by reset
  - 0002H to 000BH: Vector table for writing the program start address by interrupt

- 0020H to 007FH: Table area to be referred to by the GETI instruction
- Data Memory
  - Data area  
512 × 4 bits (000H to 1FFH)
  - Peripheral hardware area  
128 × 4 bits (F80H to FFFH)

**Figure 4-1 Program Memory Map (μPD75112(A))**

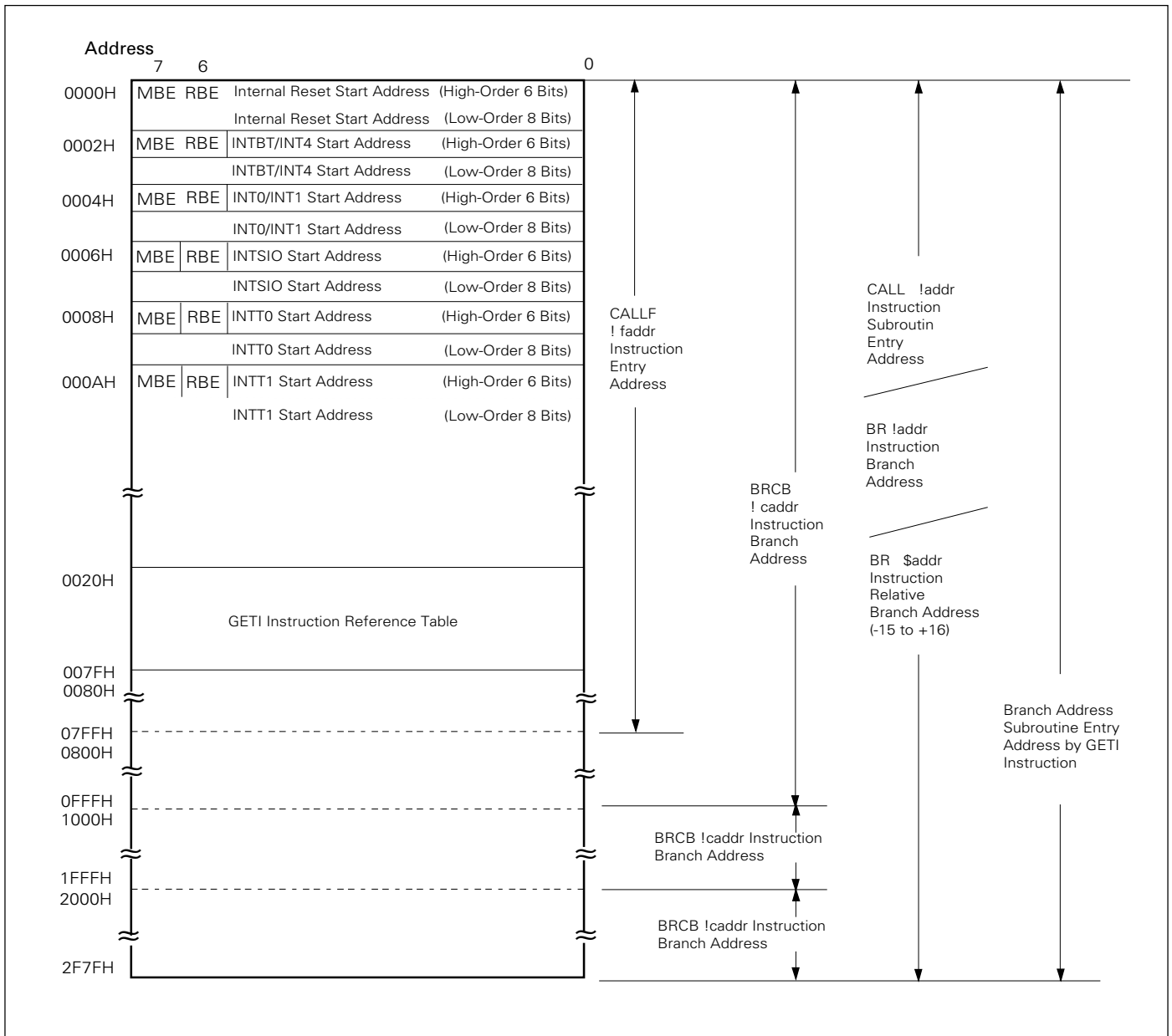

**Remarks:** In all other cases, the program can be branched by the BR PCDE and BR PCXA

instructions to an address with only the lower 8 bits of PC changed.

## μPD75112(A), 75116(A)

Figure 4-2 Program Memory Map (μPD75116(A))

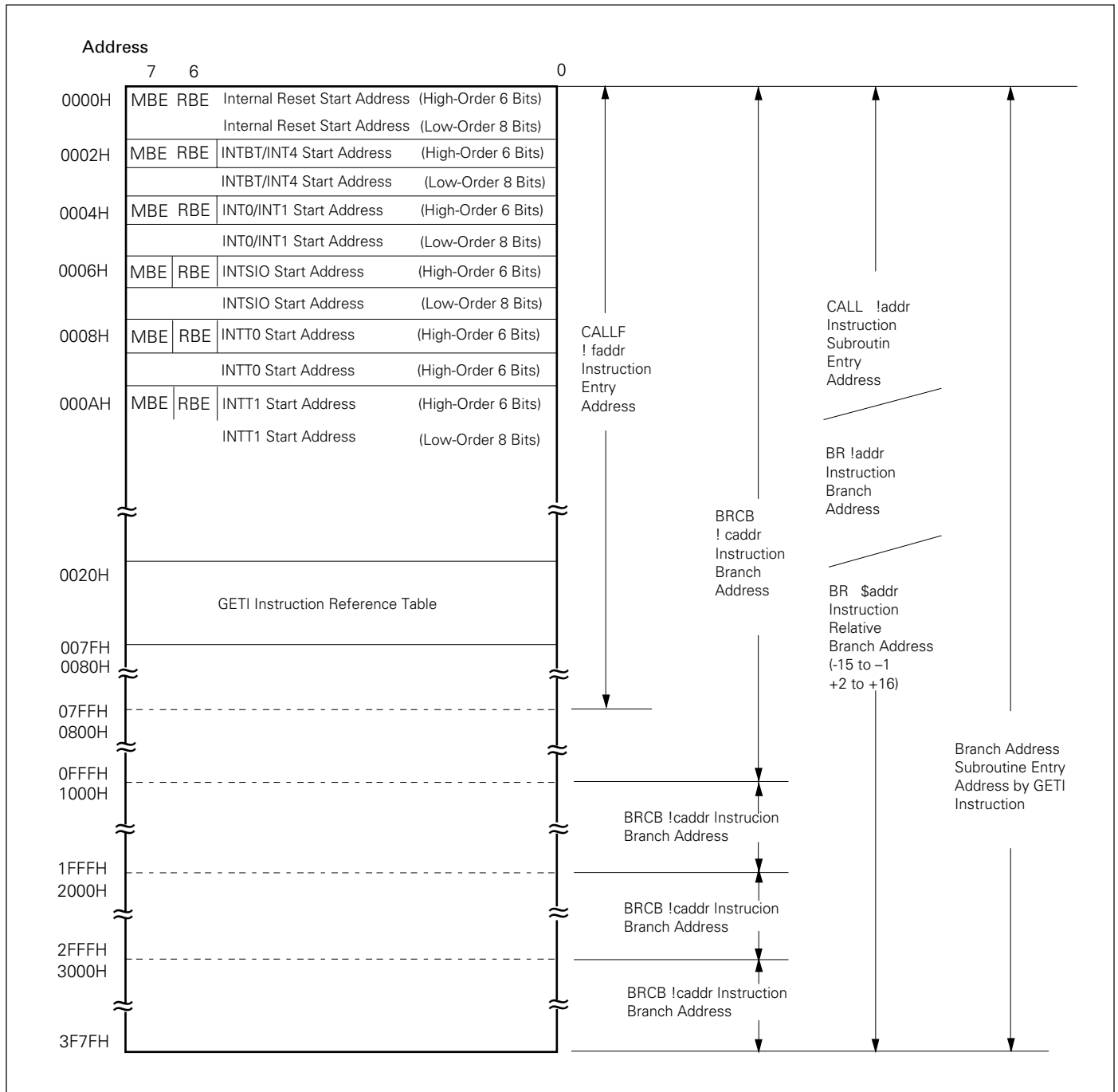

**Remarks:** In all other cases, the program can be branched by the BR PCDE and BR PCXA instructions to an address with only the lower 8 bits of PC changed.

Figure 4-3 Data Memory Map

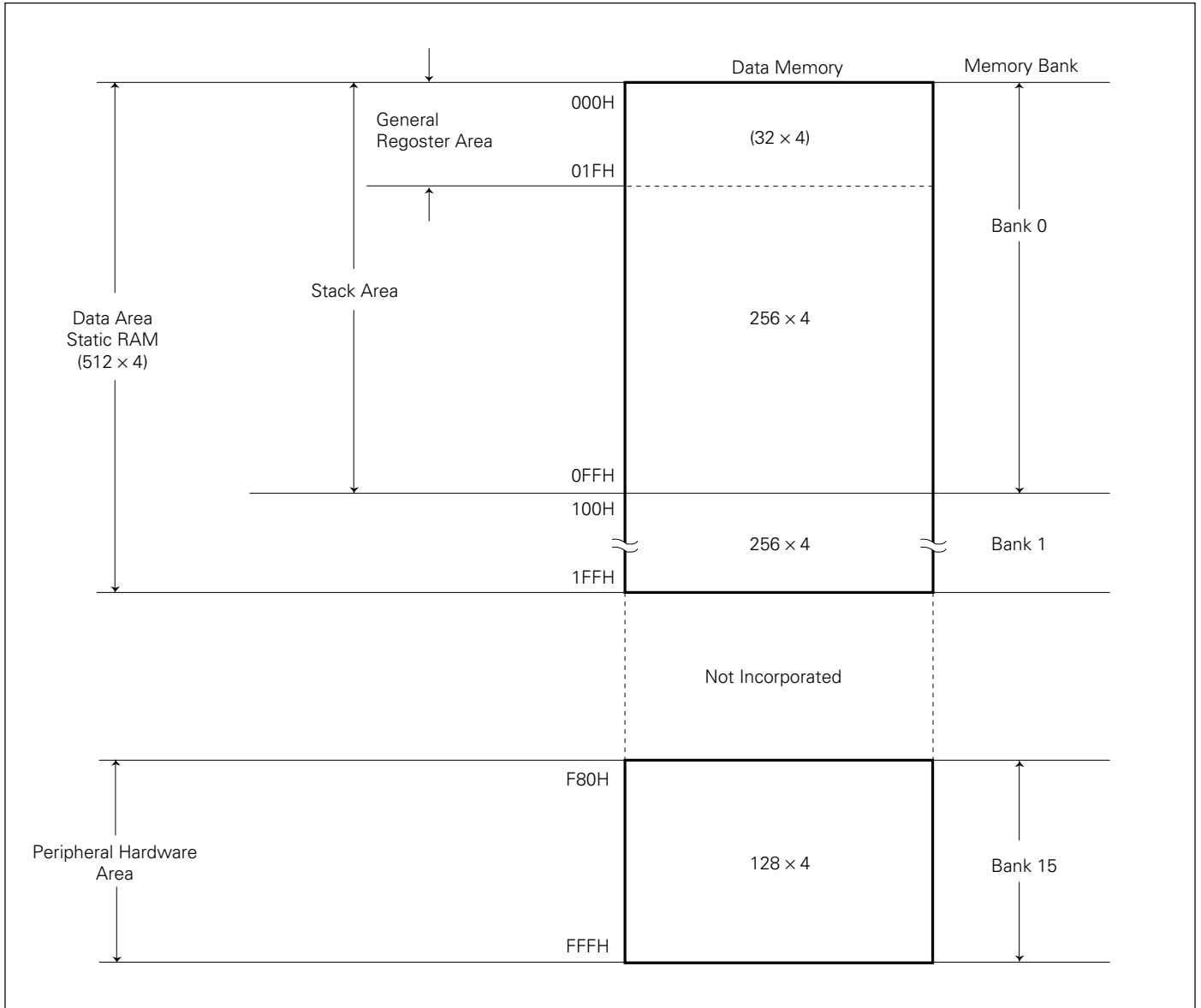

## $\mu$ PD75112(A), 75116(A)

### 5. Peripheral Hardware Functions

#### 5.1 Digital Input/Output Port

The digital input/output port has the following tree types.

• CMOS input (PORT0, 1)	: 8
• CMOS input/output (PORT 2 to PORT 9)	: 32
• N-ch open-drain input/output (PORT 12 to PORT 14):	12
<hr/>	
Total	52

**Table 5-1 Functions of Digital Ports**

Port (Code)	Functions	Operations and Features	Remarks
PORT0 PORT1	4-bit input	Read or test always enable irrespectively of the operating mode of dual-function pins.	Share the pins with SI, SO, $\overline{\text{SCK}}$ and INT0 to 4.
PORT3 PORT6	4-bit input/ output	Can be set bit-wise to the input or output mode.	
PORT2 PORT4 PORT5 PORT7 PORT8 PORT9		Can be set in 4-bit units to the input or output mode. Ports 4 and 5, 6 and 7, 8 and 9 can form pairs and data can be input/output in 8-bit units.	Port 2 shares the pin with PTO0, PTO1 and PCL.
PORT12 PORT13 PORT14	4-bit input/ output (N-ch open-drain, 12 V withstand voltage)	Can be set in 4-bit units the input or output mode. Ports 12 and 13 can form a pair and data can be input/output in 8-bit units.	On-chip pull-up registers can be specified bit-wise by mask option.

#### 5.2 Clock Generator

The clock generator is a circuit which supplies the CPU and peripheral hardware with various clocks and controls the CPU operating mode.

The instruction execution time can be changed.

- 0.95  $\mu$ s/1.91  $\mu$ s/15.3  $\mu$ s (at 4.19 MHz operation)

Figure 5-1 Block Diagram of Clock Generator ★

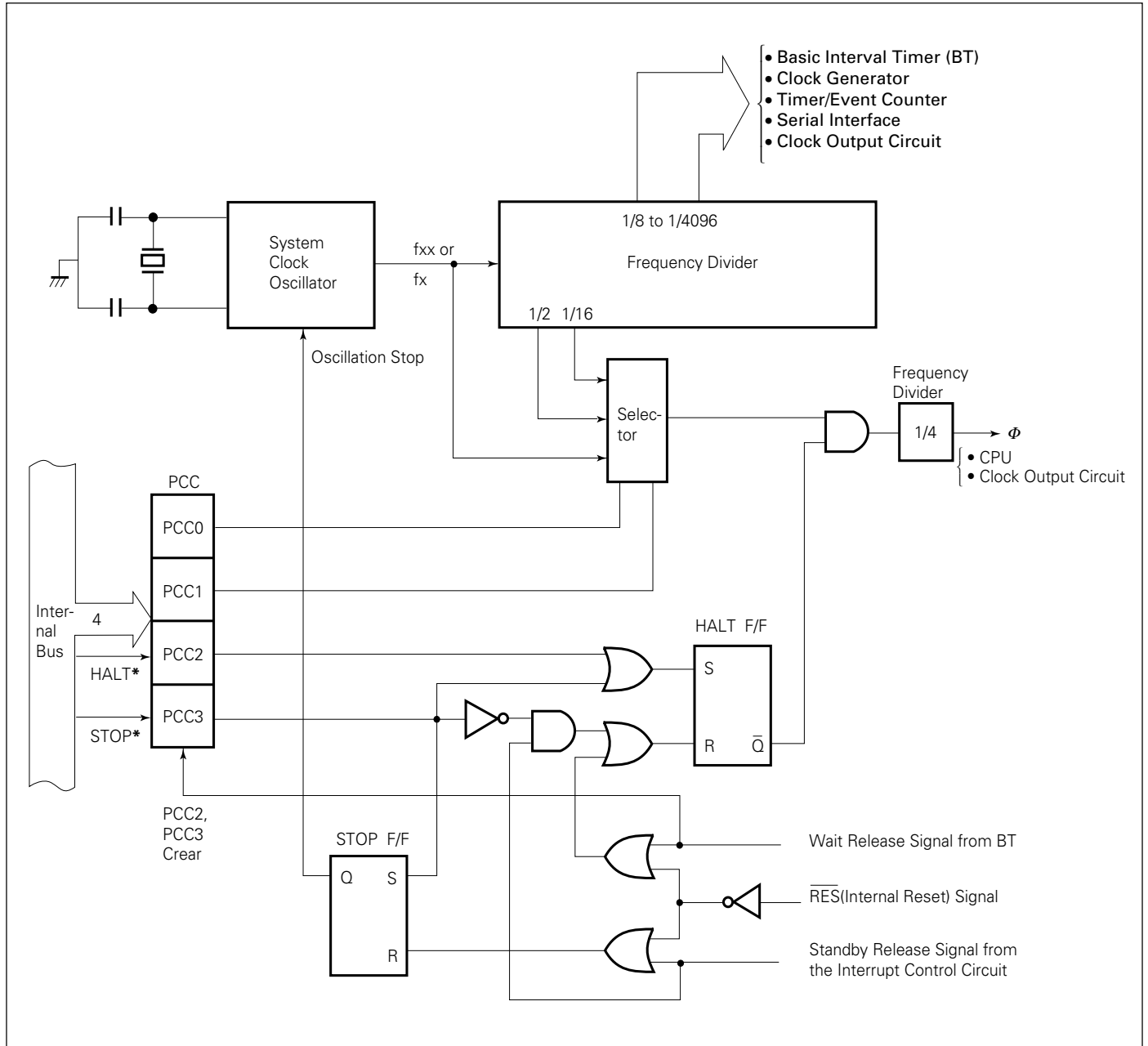

- Remarks**
- 1:  $f_{xx}$ =crystal/ceramic oscillator frequency.
  - 2:  $f_x$ =external clock frequency.
  - 3:  $\Phi$ =CPU clock
  - 4: \*indicates instruction execution.
  - 5: PCC (processor clock control register)
  - 6: 1 clock cycle ( $t_{CY}$ ) of  $\Phi$  is 1 machine cycle of the instruction. For  $t_{CY}$ , see the AC characteristics in the 11."Electrical Specifications".

## $\mu$ PD75112(A), 75116(A)

### 5.3 Clock Output Circuit

The clock output circuit is a circuit to generate clock pulses from the P22/PCL pin. It is used to supply the peripheral LSIs with clock pulses.

- Clock output (PCL):  $\Phi$ , 524 kHz, 262 kHz (at 4.19 MHz operation)

The clock output circuit configuration is shown as the following.

**Figure 5-2 Clock Output Circuit Configuration**

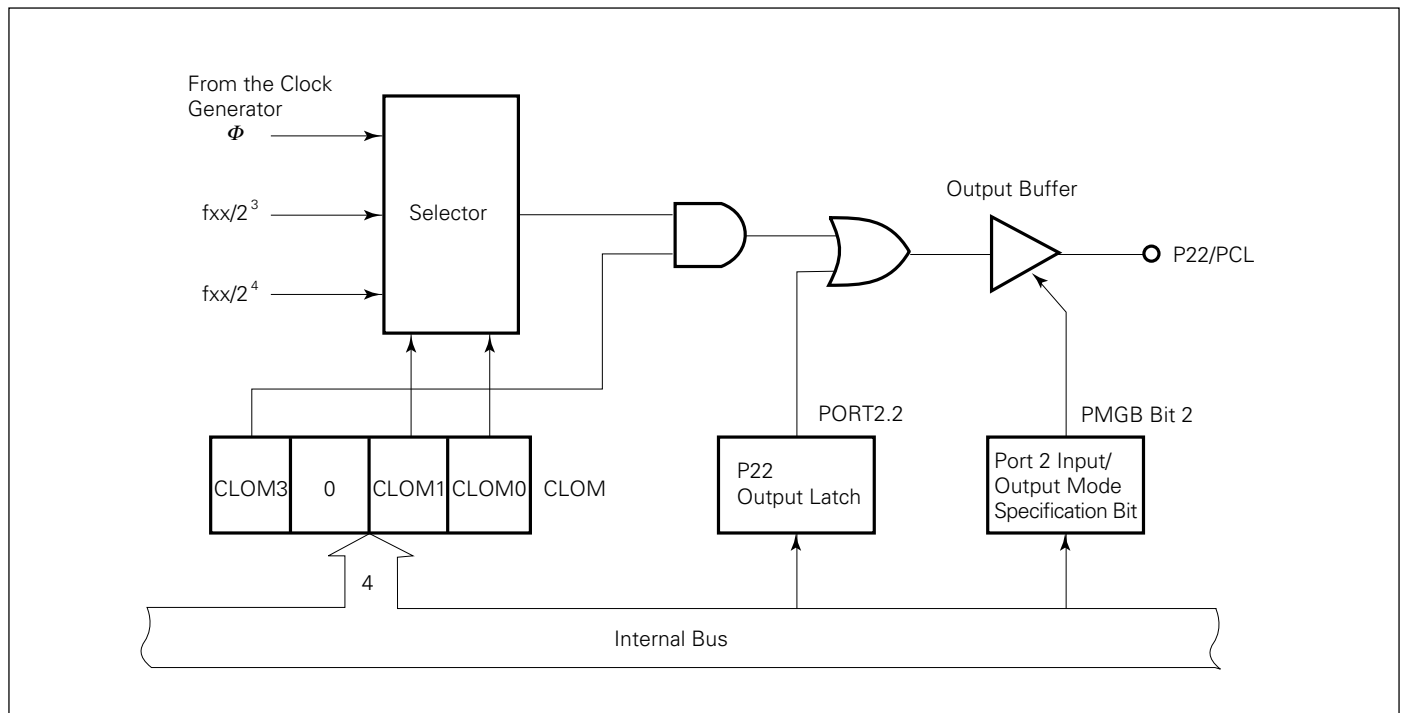

### 5.4 Basic Interval Timer

The basic interval timer has the following functions;

- Interval timer operation to generate reference time interrupts
- Watchdog timer application to detect program overrun
- Wait time selection and count when the standby mode is released
- Count content read





Figure 5-4 Block Diagram of Timer/Event Counter (n=0, 1)

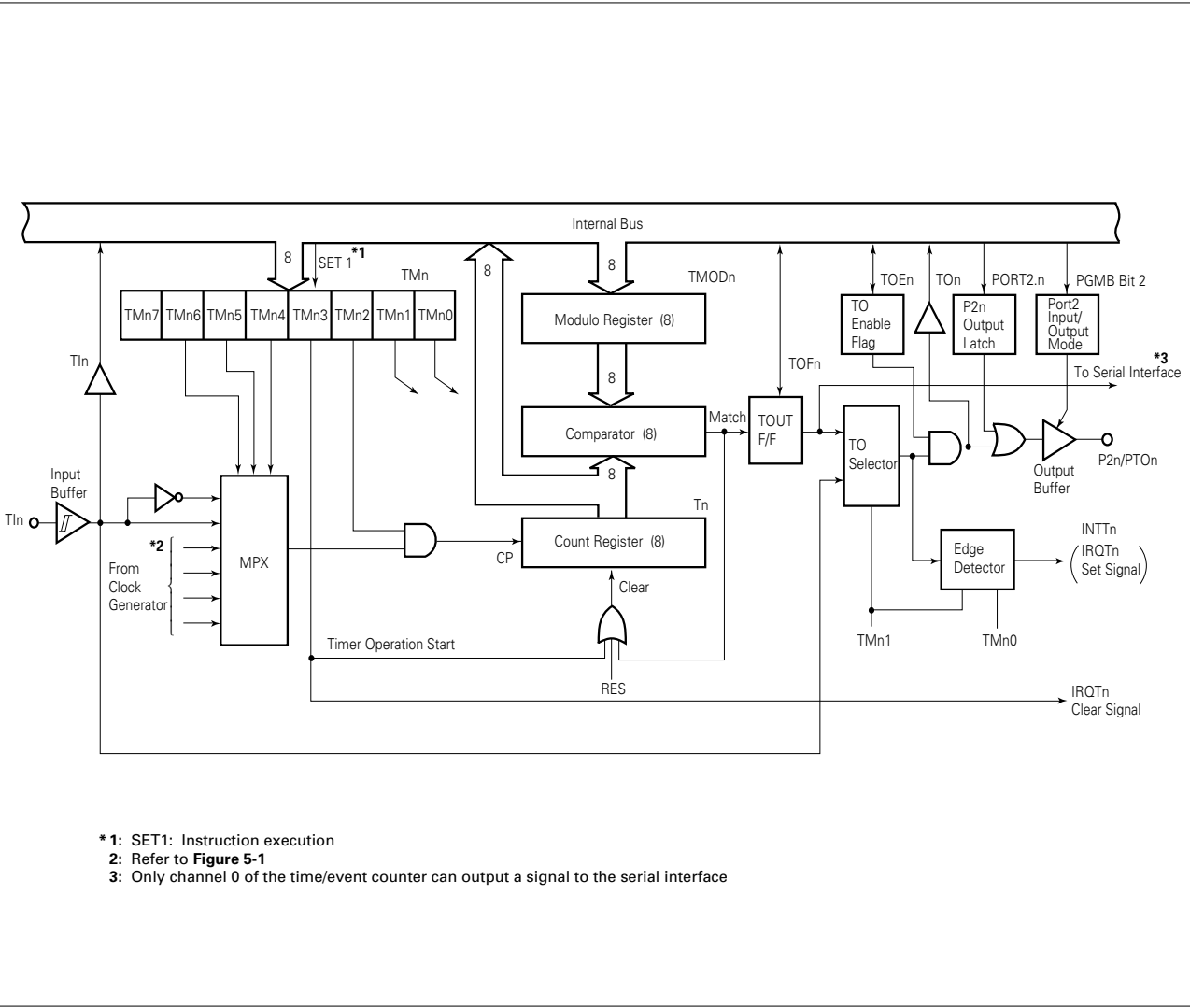

### 5.6 Serial Interface

The  $\mu$ PD75116(A) incorporates the clock synchronous 8-bit serial interface. The serial interface has the following two modes.

- Operation stop mode
- 3-wire serial I/O mode (MSB/LSB top switching possible)

Connection with the  $\mu$ PD75116(A) and the 75X series, 78K series and various I/O devices is possible in the 3-wire serial I/O mode.

Figure 5-5 Block Diagram of Serial Interface

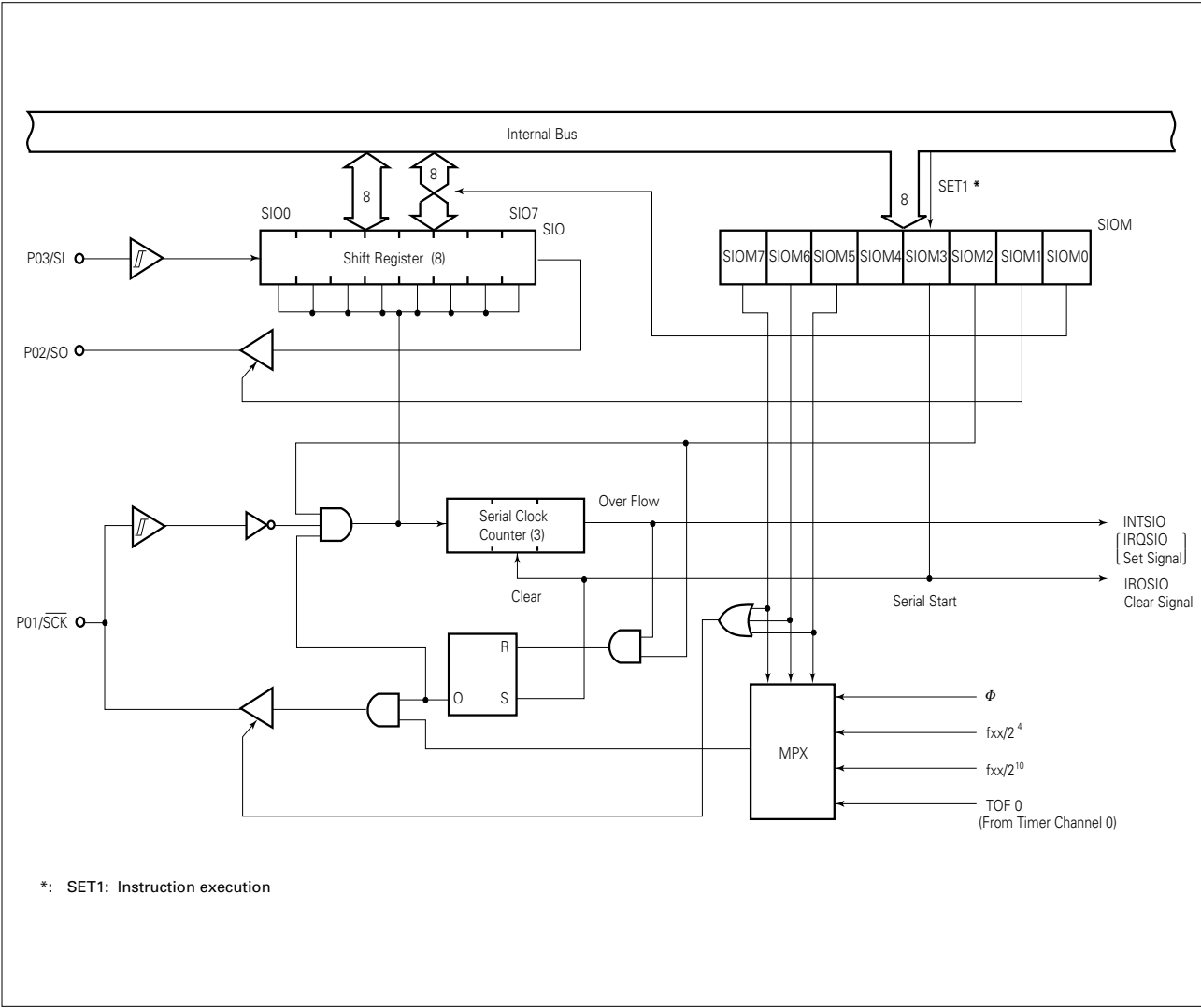

### 5.7 Programmable Threshold Port (Analog Input Port)

The μPD75116(A) is equipped with 4-bit analog input pins (PTH00 to PTH03) capable of changing the threshold voltage. These pins are configured as shown in Figure 5-6.

Sixteen threshold voltage ( $V_{REF}$ ) values ( $V_{DD} \times \frac{0.5}{16} - V_{DD} \times \frac{15.5}{16}$ ) are available and analog signals can be directly input.

The analog input port can also be used as a digital signal input port by selecting  $V_{DD} \times \frac{7.5}{16}$  for  $V_{REF}$ .

**Figure 5-6 Block Diagram of Programmable Threshold Port**

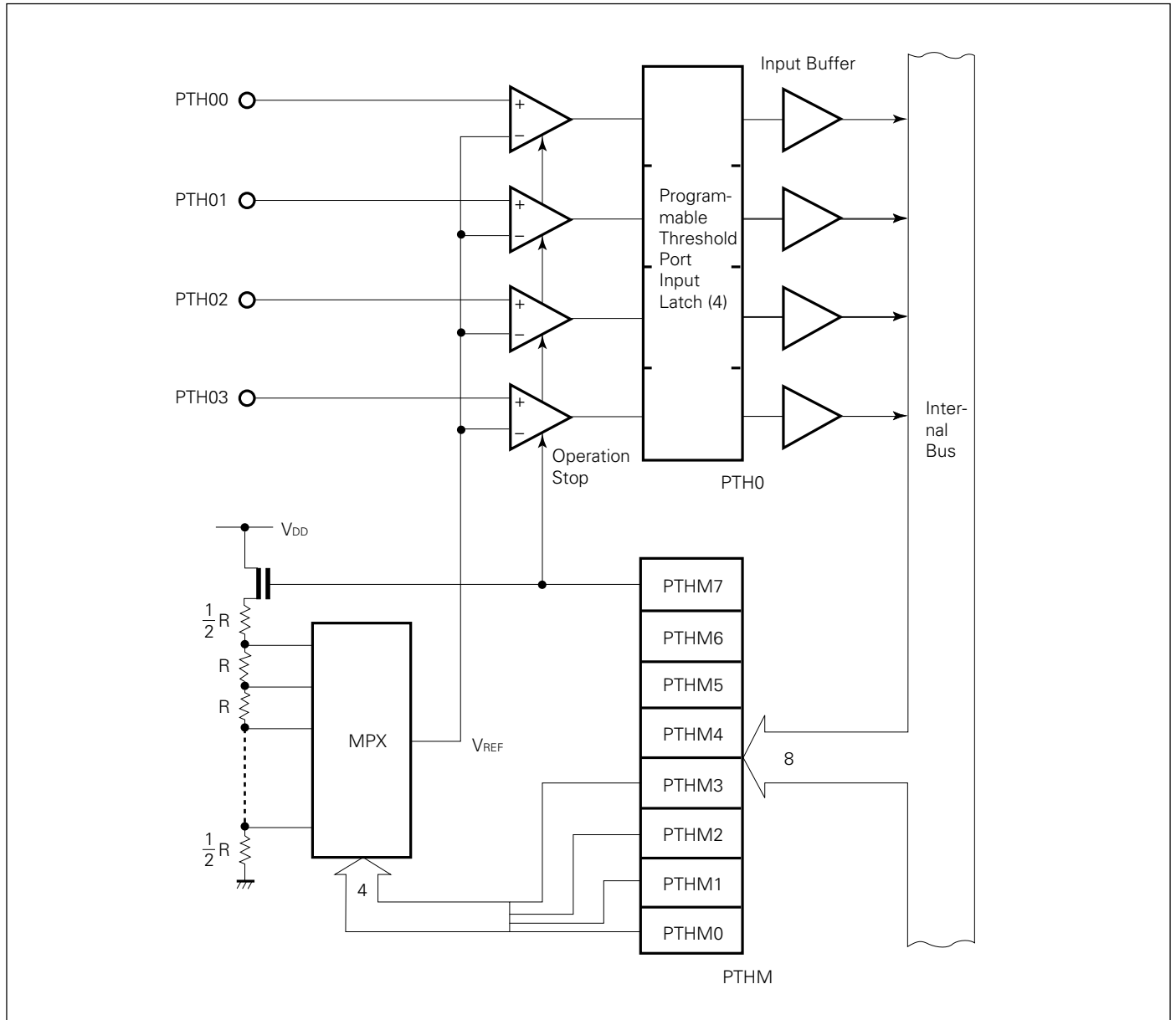

## $\mu$ PD75112(A), 75116(A)

### 5.8 Bit Sequential Buffer ... 16 bit

The bit sequential buffer is a special data memory for bit control. Since this buffer can easily operate bits by sequentially changing address and bit specifications, it can be conveniently be used for bit-wise processing of data having long bit lengths.

**Figure 5-7 Bit Sequential Buffer Format**

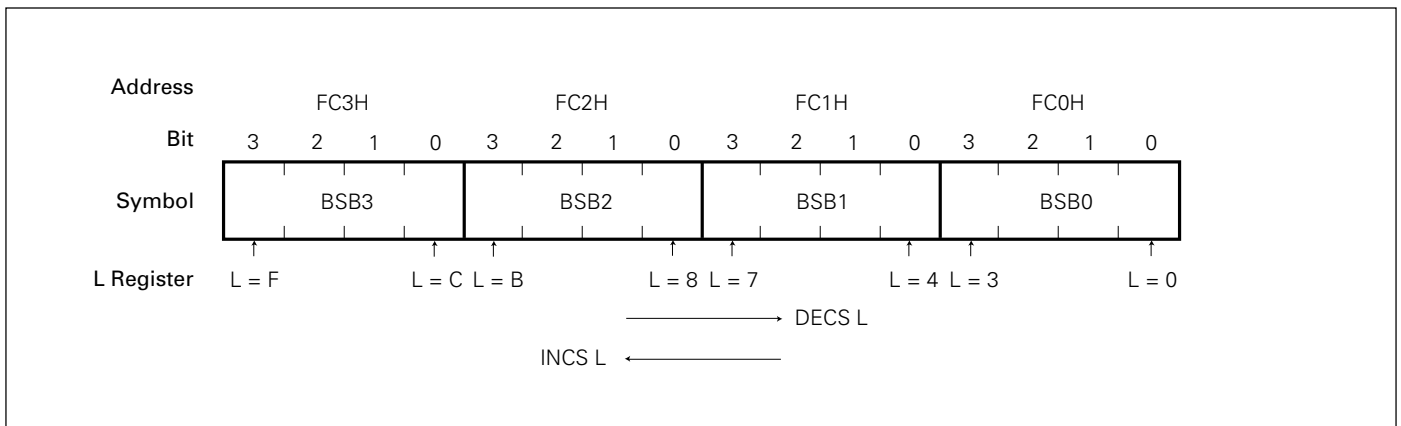

**Remarks:** In pmen. @L addressing, the specified bit moves in accordance with the L register.

### 5.9 Power-On Flag (Mask Option)

The power-on flag (PONF) is only set (1) when the power-on reset circuit is activated and the power-on reset signal is generated (see **Figure 8-1**).

PONF is mapped on bit 0 at address FD1H of the data memory space and is manipulated by a bit manipulation instruction

However, it cannot be set(1) by the SET1 instruction.

### 6. Interrupt Functions

There are seven types of interrupt sources for the  $\mu$ PD75116(A) to allow multi-interruption with priority.

The  $\mu$ PD75116(A) is also provided with two types of edge detection testable inputs.

The  $\mu$ PD75116 interrupt control circuit has the following functions;

- Hardware controlled vector interrupt function which enables to control by the interrupt enable flag (IE $\times\times\times$ ) and the interrupt master enable flag (IME) whether an interrupt should be enabled.
- Interrupt start address can be set freely.
- Multiple interrupt function which enables to specify priority by the interrupt priority select register (IPS).
- Interrupt request flag (IRQ $\times\times\times$ ) test function (interrupt generation can be checked by the software).
- Standby mode release (the interrupt to be released can be selected by the interrupt enable flag).

Figure 6-1 Block Diagram of Interrupt Control Circuit

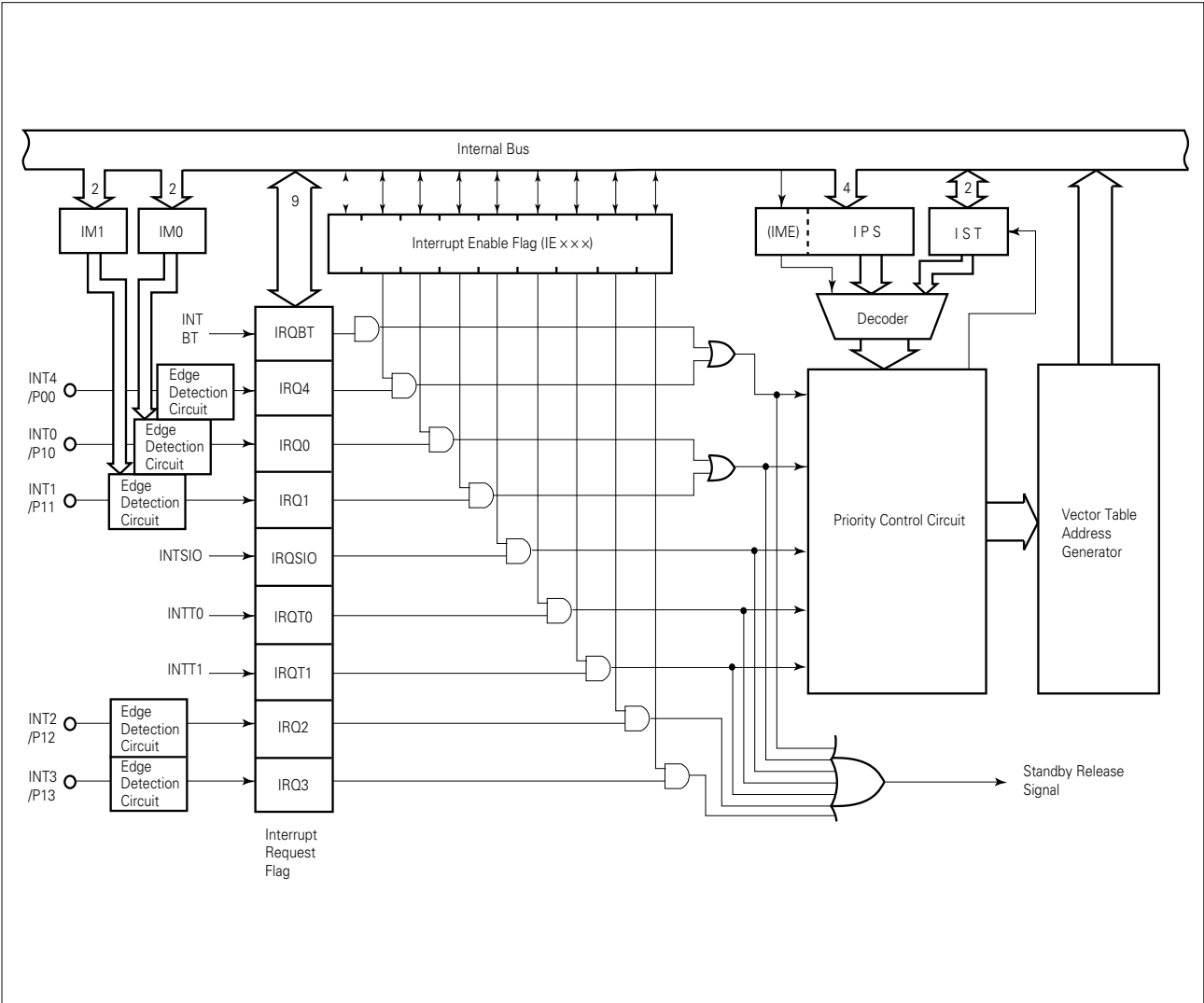



### 7. Standby Functions

Two types of standby modes (STOP and HALT modes) are available for the μPD75116(A) to decrease power consumption during standby for program.

**Table 7-1 Operation Statuses in Standby Mode**

		STOP Mode	HALT Mode
Set instruction		STOP instruction	HALT instruction
Operation status	Clock generator	Clock oscillation stop	Only CPU clock $\phi$ stop
	Basic interval timer	Operation stop	Operation (IRQBT set at reference time intervals)
	Serial interface	Operation enabled only when external $\overline{SCK}$ input and TO0 clock are set for serial clocks (when timer/event counter 0 is set to external TI0 input) is selected	Operation enabled when a clock other than $\phi$ is specified for the serial clock
	Timer/event counter	Operation enabled only when TIn pin input is specified for the count clock	Operation enabled
	Clock output circuit	Operation stop	Clock other than CPU clock $\phi$ enabled for output
	CPU	Operation stop	Operation stop
Release signal		Interrupt request signal enabled by interrupt enable flag or $\overline{RESET}$ input	

## $\mu$ PD75112(A), 75116(A)

### 8. Reset Functions

The reset signal ( $\overline{\text{RES}}$ ) generator is configured as shown in Figure 8-1.

**Figure 8-1 Reset Signal Generator**

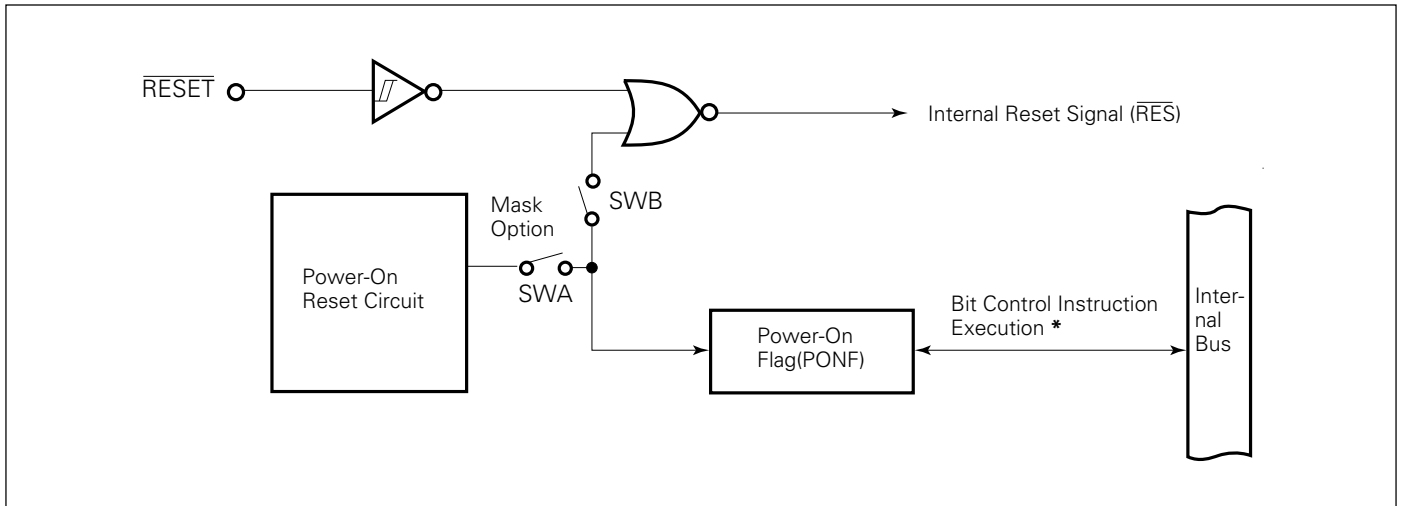

\*: PONF setting (1) by SET1 instruction is not possible.

The power-on reset circuit generates the internal reset signal by rising of supply voltage. This pulse is used in the three ways according to the specification of mask option of SWA and SWB shown in Figure 8-1 (refer to "10. Mask Option Selection").

Reset operations are shown in Figures 8-2 and 8-3.

**Figure 8-2 Reset Operation by Power-on Reset**

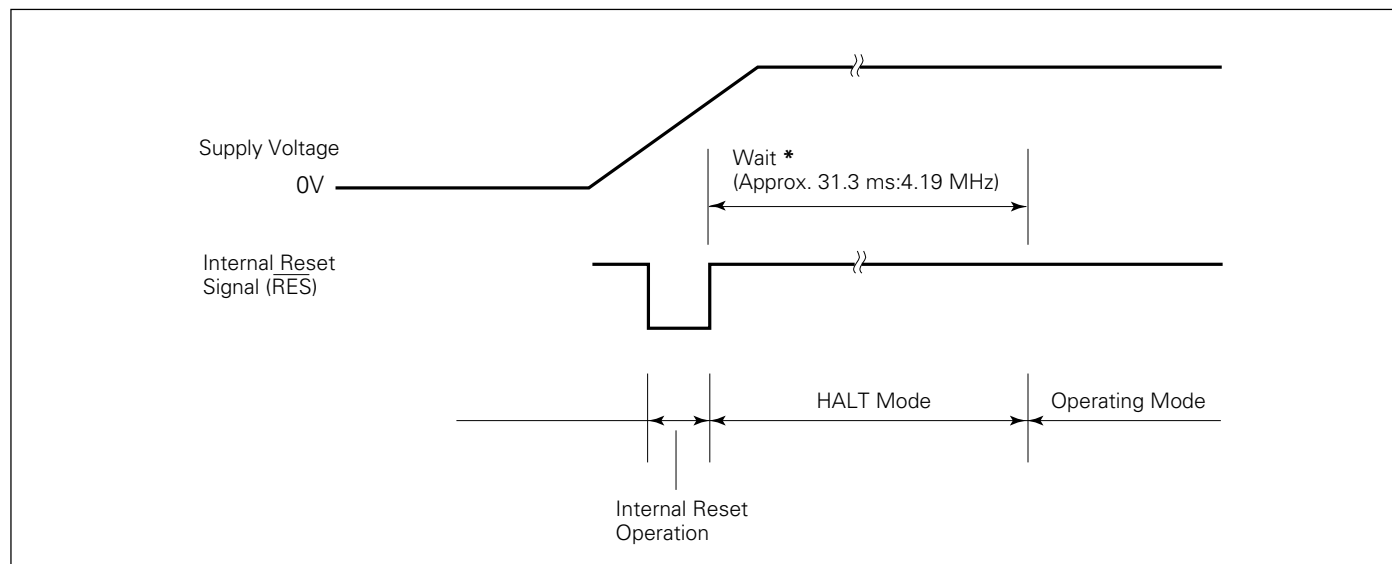

**Figure 8-3 Reset Operation by  $\overline{\text{Reset}}$  Input**

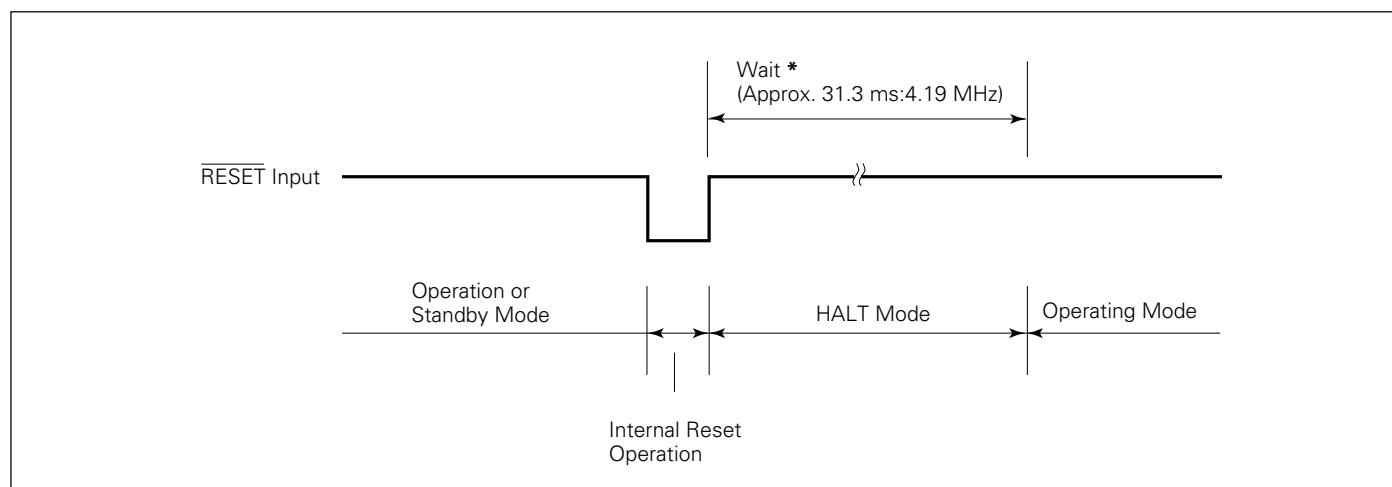

\*: The wait time does not include a time from the generation of  $\overline{\text{RES}}$  signal to the start of oscillation.

Each hardware status after reset operation is shown in Table 8-1.

## μPD75112(A), 75116(A)

**Table 8-1 Hardware Statuses after Reset**

Hardware		$\overline{\text{RESET}}$ Input in Standby Mode	$\overline{\text{RESET}}$ Input in Power-On Reset or Operation
Program counter (PC)		Lower 6 bits of address 0000H of the program memory are set to PC13 to PC8 and the content of address 0001H is set to PC7 to PC0.	same as left
PWS	Carry flag (CY)	Hold	Undefined
	Skip flag (SK0 to SK2)	0	0
	Interrupt status flag (IST0, 1)	0	0
	Bank enable flags (MBE, RBE)	Bits 6 and 7 of address 0000H of the program memory are set to RBE and MBE, respectively.	same as left
Stack pointer (SP)		Undefined	Undefined
Data memory (RAM)		Hold *1	Undefined
General registers (X, A, H, L, D, E, B, C)		Hold	Undefined
Bank select registers (MBS, RBS)		0, 0	0, 0
Basic interval timer	Counter (BT)	Undefined	Undefined
	Mode register (BTM)	0	0
Timer/ event counter (n = 0, 1)	Counter (Tn)	0	0
	Modulo register (TMODn)	FFH	FFH
	Mode register (TMn)	0	0
	TOEn, TOFn	0, 0	0, 0
Serial interface	Shift register (SIO)	Hold	Undefined
	Mode register (SIOM)	0	0
Clock generator, clock output circuit	Processor clock control register (PCC)	0	0
	Clock output mode register (CLOM)	0	0
Interrupt	Interrupt request flag (IRQ <sub>xxx</sub> )	Reset (0)	Reset (0)
	Interrupt enable flag (IE <sub>xxx</sub> )	0	0
	Priority select register (IPS)	0	0
	INT0, 1 mode registers (IM0, IM1)	0, 0	0, 0
Digital port	Output buffer	Off	Off
	Output latch	Clear (0)	Clear (0)
	Input/output mode registers (PMGA, PMGB, PMGC)	0	0
Analog port	PTH00 to PTH03 input latches	Undefined	Undefined
	Mode register (PTHM)	0	0
Power-on flag (PONF)		Hold	1 or undefined *2
Bit sequential buffers (BSB0 to BSB3)		0	0

\* 1: Power-on reset ..... 1  
 $\overline{\text{RESET}}$  input in operation ... Undefined

2: Data at addresses 0F8H to 0FDH of the data memory becomes undefined due to  $\overline{\text{RESET}}$  input.

### 9. Instruction Set

#### (1) Operand identifier and description method

In the operand column of each instruction, describe the corresponding operand in accordance with the description method for the operand identifier of the instruction (refer to the "RA75X Assembler Package User's Manual Language Volume" (EEU-730) for details). If more than one description method is available, select one of them. Capital alphabetic letters, plus and minus signs are key words. Describe them as they are.

In the case of immediate data, describe appropriate numeric values or labels.

Symbols of various registers and flags can be described as labels instead of mem, fmem, pmem, bit, etc. (Refer to the "μPD751×× Series User's Manual (IEM-922)" for details). Labels which can be described are limited for fmem and pmem.

Identifier	Description Method	
reg reg1	X, A, B, C, D, E, H, L X, B, C, D, E, H, L	
rp rp1 rp2 rp' rp'1	XA, BC, DE, HL BC, DE, HL BC, DE XA, BC, DE, HL, XA', BC', DE', HL' BC, DE, HL, XA', BC', DE', HL'	
rpa rpa1	HL, HL+, HL-, DE, DL DE, DL	
n4 n8	4-bit immediate data or label 8-bit immediate data or label	
mem bit	8-bit immediate data or label* 2-bit immediate data or label	
fmem pmem	FB0H to FBFH and FF0H to FFFH immediate data or labels FC0H to FFFH immediate data or labels	
addr	μPD75112(A)	0000H to 2F7FH immediate data or labels
	μPD75116(A)	0000H to 3F7FH immediate data or labels
caddr	12-bit immediate data or label	
faddr	11-bit immediate data or label	
taddr	20H to 7FH immediate data (bit = 0) or labels	
PORTn IExxx RBn MBn	PORT0 to PORT9, PORT12 to PORT14 IEBT, IESIO, IET0, IET1, IE0 to IE4 RB0 to RB3 MB0, MB1, MB15	

\*: In the case of 8-bit data processing, only even address can be described for "mem".

## $\mu$ PD75112(A), 75116(A)

---

### (2) Legend in the description of operations

A	:	A register; 4-bit accumulator
B	:	B register
C	:	C register
D	:	D register
E	:	E register
H	:	H register
L	:	L register
X	:	X register
XA	:	Register pair (XA); 8-bit accumulator
BC	:	Register pair (BC)
DE	:	Register pair (DE)
HL	:	Register pair (HL)
XA'	:	Extended register pair (XA')
BC'	:	Extended register pair (BC')
DE'	:	Extended register pair (DE')
HL'	:	Extended register pair (HL')
PC	:	Program counter
SP	:	Stack pointer
CY	:	Carry flag; bit accumulator
PSW	:	Program status word
MBE	:	Memory bank enable flag
RBE	:	Register bank enable flag
PORT <sub>n</sub>	:	Port n (n = 0 to 9, 12 to 14)
IME	:	Interrupt mask enable flag
IPS	:	Interrupt priority select register
IE <sub>xxx</sub>	:	Interrupt enable flag
RBS	:	Register bank select register
MBS	:	Memory bank select register
PCC	:	Processor clock control register
.	:	Address and bit division
(xx)	:	Content addressed by xx
xxH	:	Hexadecimal data



## $\mu$ PD75112(A), 75116(A)

Instructions	Mnemonic	Operand	No. of Bytes	Machine Cycle	Operation	Addressing Area	Skip Condition	
<b>Transfer</b>	MOV	A, #n4	1	1	A←n4		Stack A	
		reg1, #n4	2	2	reg1←n4			
		XA, #n8	2	2	XA←n8		Stack A	
		HL, #n8	2	2	HL←n8		Stack B	
		rp2, #n8	2	2	rp2←n8			
		A, @HL	1	1	A←(HL)	*1		
		A, @HL+	1	2+S	A←(HL), then L←L+1	*1	L=0	
		A, @HL-	1	2+S	A←(HL), then L←L-1	*1	L=FH	
		A, @rpa1	1	1	A←(rpa1)	*2		
		XA, @HL	2	2	XA←(HL)	*1		
		@HL, A	1	1	(HL)←A	*1		
		@HL, XA	2	2	(HL)←XA	*1		
		A, mem	2	2	A←(mem)	*3		
		XA, mem	2	2	XA←(mem)	*3		
		mem, A	2	2	(mem)←A	*3		
		mem, XA	2	2	(mem)←XA	*3		
		A, reg	2	2	A←reg			
		XA, rp'	2	2	XA←rp'			
		reg1, A	2	2	reg1←A			
		rp'1 XA	2	2	rp'1←XA			
	XCH	A, @HL	1	1	A↔(HL)	*1		
		A, @HL+	1	2+S	A↔(HL), then L←L+1	*1	L=0	
		A, @HL-	1	2+S	A↔(HL), then L←L-1	*1	L=FH	
		A, @rpa1	1	1	A↔(rpa1)	*2		
		XA, @HL	2	2	XA↔(HL)	*1		
		A, mem	2	2	A↔(mem)	*3		
		XA, mem	2	2	XA↔(mem)	*3		
		A, reg1	1	1	A↔reg1			
		XA, rp'	2	2	XA↔rp'			
	<b>Table Reference</b>	MOVT	XA, @PCDE	1	3	XA←(PC13-8+DE) <sub>ROM</sub>		
			XA, @PCXA	1	3	XA←(PC13-8+XA) <sub>ROM</sub>		
	<b>Bit Transfer</b>	MOV1	CY, fmem. bit	2	2	CY←(fmem.bit)	*4	
			CY, pmem. @L	2	2	CY←(pmem7-2+L3-2.bit(L1-0))	*5	
CY, @H+mem. bit			2	2	CY←(H+mem3-0.bit)	*1		
fmem. bit, CY			2	2	(fmem.bit)←CY	*4		
pmem. @L, CY			2	2	(pmem7-2+L3-2.bit(L1-0))←CY	*5		
@H+mem. bit, CY			2	2	(H+mem3-0.bit)←CY	*1		



Instructions	Mnemonic	Operand	No. of Bytes	Machine Cycle	Operation	Addressing Area	Skip Condition	
<b>Arithmetic</b>	ADDS	A, #n4	1	1+S	$A \leftarrow A+n4$		Carry	
		XA, #n8	2	2+S	$XA \leftarrow XA+n8$		Carry	
		A, @HL	1	1+S	$A \leftarrow A+(HL)$	*1	Carry	
		XA, rp'	2	2+S	$XA \leftarrow XA+rp'$		Carry	
		rp'1, XA	2	2+S	$rp'1 \leftarrow rp'1+XA$		Carry	
	ADDC	A, @HL	1	1	$A, CY \leftarrow A+(HL)+CY$	*1		
		XA, rp'	2	2	$XA, CY \leftarrow XA+rp'+CY$			
		rp'1, XA	2	2	$rp'1, CY \leftarrow rp'1+XA+CY$			
	SUBS	A, @HL	1	1+S	$A \leftarrow A-(HL)$	*1	borrow	
		XA, rp'	2	2+S	$XA \leftarrow XA-rp'$		borrow	
		rp'1, XA	2	2+S	$rp'1 \leftarrow rp'1-XA$		borrow	
	SUBC	A, @HL	1	1	$A, CY \leftarrow A-(HL)-CY$	*1		
		XA, rp'	2	2	$XA, CY \leftarrow XA-rp'-CY$			
		rp'1, XA	2	2	$rp'1, CY \leftarrow rp'1-XA-CY$			
	AND	A, #n4	2	2	$A \leftarrow A \wedge n4$			
		A, @HL	1	1	$A \leftarrow A \wedge (HL)$	*1		
		XA, rp'	2	2	$XA \leftarrow XA \wedge rp'$			
		rp'1, XA	2	2	$rp'1 \leftarrow rp'1 \wedge XA$			
	OR	A, #n4	2	2	$A \leftarrow A \vee n4$			
		A, @HL	1	1	$A \leftarrow A \vee (HL)$	*1		
		XA, rp'	2	2	$XA \leftarrow XA \vee rp'$			
		rp'1, XA	2	2	$rp'1 \leftarrow rp'1 \vee XA$			
	XOR	A, #n4	2	2	$A \leftarrow A \oplus n4$			
		A, @HL	1	1	$A \leftarrow A \oplus (HL)$	*1		
		XA, rp'	2	2	$XA \leftarrow XA \oplus rp'$			
		rp'1, XA	2	2	$rp'1 \leftarrow rp'1 \oplus XA$			
	<b>Accumulator Operation</b>	RORC	A	1	1	$CY \leftarrow A_0, A_3 \leftarrow CY, A_{n-1} \leftarrow A_n$		
		NOT	A	2	2	$A \leftarrow \bar{A}$		
<b>Increase/ Decrease</b>	INCS	reg	1	1+S	$reg \leftarrow reg+1$		reg=0	
		rp1	1	1+S	$rp1 \leftarrow rp1+1$		rp1=00H	
		@HL	2	2+S	$(HL) \leftarrow (HL)+1$	*1	(HL)=0	
		mem	2	2+S	$(mem) \leftarrow (mem)+1$	*3	(mem)=0	
	DECS	reg	1	1+S	$reg \leftarrow reg-1$		reg=FFH	
		rp'	2	2+S	$rp' \leftarrow rp'-1$		rp'=FFH	
<b>Compare</b>	SKE	reg, #n4	2	2+S	Skip if reg=n4		reg=n4	
		@HL, #n4	2	2+S	Skip if (HL)=n4	*1	(HL)=n4	
		A, @HL	1	1+S	Skip if A=(HL)	*1	A=(HL)	

## $\mu$ PD75112(A), 75116(A)

Instructions	Mnemonic	Operand	No. of Bytes	Machine Cycle	Operation	Addressing Area	Skip Condition
<b>Compare</b>	SKE	XA, @HL	2	2+S	Skip if XA=(HL)	<b>*1</b>	XA=(HL)
		A, reg	2	2+S	Skip if A=reg		A=reg
		XA, rp'	2	2+S	Skip if XA=rp'		XA=rp'
<b>Carry Flag Operation</b>	SET1	CY	1	1	CY←1		
	CLR1	CY	1	1	CY←0		
	SKT	CY	1	1+S	Skip if CY=1		CY=1
	NOT1	CY	1	1	CY←CY		

Instructions	Mnemonic	Operand	No. of Bytes	Machine Cycle	Operation	Addressing Area	Skip Condition
<b>Memory Bit Manipulation</b>	SET1	mem. bit	2	2	(mem.bit)←1	*3	
		fmem. bit	2	2	(fmem.bit)←1	*4	
		pmem. @L	2	2	(pmem7-2+L3-2.bit(L1-0))←1	*5	
		@H+mem. bit	2	2	(H+mem3-0.bit)←1	*1	
	CLR1	mem. bit	2	2	(mem.bit)←0	*3	
		fmem. bit	2	2	(fmem.bit)←0	*4	
		pmem. @L	2	2	(pmem7-2+L3-2.bit(L1-0))←0	*5	
		@H+mem. bit	2	2	(H+mem3-0.bit)←0	*1	
	SKT	mem. bit	2	2+S	Skip if (mem.bit)=1	*3	(mem.bit)=1
		fmem. bit	2	2+S	Skip if (fmem.bit)=1	*4	(fmem.bit)=1
		pmem. @L	2	2+S	Skip if (pmem7-2+L3-2.bit(L1-0))=1	*5	(pmem.@L)=1
		@H+mem. bit	2	2+S	Skip if (H+mem3-0.bit)=1	*1	(@H+mem.bit)=1
	SKF	mem. bit	2	2+S	Skip if (mem.bit)=0	*3	(mem.bit)=0
		fmem. bit	2	2+S	Skip if (fmem.bit)=0	*4	(fmem.bit)=0
		pmem. @L	2	2+S	Skip if (pmem7-2+L3-2.bit(L1-0))=0	*5	(pmem.@L)=0
		@H+mem. bit	2	2+S	Skip if (H+mem3-0.bit)=0	*1	(@H+mem.bit)=0
	SKTCLR	fmem. bit	2	2+S	Skip if (fmem.bit)=1 and clear	*4	(fmem.bit)=1
		pmem. @L	2	2+S	Skip if (pmem7-2+L3-2.bit(L1-0))=1 and clear	*5	(pmem.@L)=1
		@H+mem. bit	2	2+S	Skip if (H+mem3-0.bit)=1 and clear	*1	(@H+mem.bit)=1
	AND1	CY, fmem. bit	2	2	CY ← CY ∧ (fmem.bit)	*4	
		CY, pmem. @L	2	2	CY ← CY ∧ (pmem7-2+L3-2.bit(L1-0))	*5	
		CY, @H+mem. bit	2	2	CY ← CY ∧ (H+mem3-0.bit)	*1	
	OR1	CY, fmem. bit	2	2	CY ← CY ∨ (fmem.bit)	*4	
		CY, pmem. @L	2	2	CY ← CY ∨ (pmem7-2+L3-2.bit(L1-0))	*5	
CY, @H+mem. bit		2	2	CY ← CY ∨ (H+mem3-0.bit)	*1		
XOR1	CY, fmem. bit	2	2	CY ← CY ⊕ (fmem.bit)	*4		
	CY, pmem. @L	2	2	CY ← CY ⊕ (pmem7-2+L3-2.bit(L1-0))	*5		
	CY, @H+mem. bit	2	2	CY ← CY ⊕ (H+mem3-0.bit)	*1		
<b>Branch</b>	BR	addr	—	—	PC <sub>13-0</sub> ← addr (Most appropriate instruction is selected by assembler from among BR !addr, BR CB !caddr and BR \$addr)	*6	
		!addr	3	3	PC <sub>13-0</sub> ← addr	*6	
		\$addr	1	2	PC <sub>13-0</sub> ← addr	*7	
	BRCB	!caddr	2	2	PC <sub>13-0</sub> ← PC <sub>13, 12</sub> + caddr <sub>11-0</sub>	*8	
	BR	PCDE	2	3	PC <sub>13-0</sub> ← PC <sub>13-8</sub> + DE		
		PCXA	2	3	PC <sub>13-0</sub> ← PC <sub>13-8</sub> + XA		

## $\mu$ PD75112(A), 75116(A)

Instructions	Mnemonic	Operand	No. of Bytes	Machine Cycle	Operation	Addressing Area	Skip Condition	
<b>Subroutine Stack Control</b>	CALL	!addr	3	3	(SP-4)(SP-1)(SP-2) $\leftarrow$ PC <sub>11-0</sub> (SP-3) $\leftarrow$ MBE, RBE, PC <sub>13, 12</sub> PC <sub>13-0</sub> $\leftarrow$ addr, SP $\leftarrow$ SP-4	<b>*6</b>		
	CALLF	!faddr	2	2	(SP-4)(SP-1)(SP-2) $\leftarrow$ PC <sub>11-0</sub> (SP-3) $\leftarrow$ MBE, RBE, PC <sub>13, 12</sub> PC <sub>13-0</sub> $\leftarrow$ 00, faddr, SP $\leftarrow$ SP-4	<b>*9</b>		
	RET		1	3	MBE, RBE, PC <sub>13, 12</sub> $\leftarrow$ (SP+1) PC <sub>11-0</sub> $\leftarrow$ (SP)(SP+3)(SP+2) SP $\leftarrow$ SP+4			
	RETS		1	3+S	MBE, RBE, PC <sub>13, 12</sub> $\leftarrow$ (SP+1) PC <sub>11-0</sub> $\leftarrow$ (SP)(SP+3)(SP+2) SP $\leftarrow$ SP+4, then skip unconditionally		Unconditional	
	RETI		1	3	PC <sub>13, 12</sub> $\leftarrow$ (SP+1) PC <sub>11-0</sub> $\leftarrow$ (SP)(SP+3)(SP+2) PSW $\leftarrow$ (SP+4)(SP+5), SP $\leftarrow$ SP+6			
	PUSH	rp		1	1	(SP-1)(SP-2) $\leftarrow$ rp, SP $\leftarrow$ SP-2		
		BS		2	2	(SP-1) $\leftarrow$ MBS, (SP-2) $\leftarrow$ RBS, SP $\leftarrow$ SP-2		
	POP	rp		1	1	rp $\leftarrow$ (SP-1)(SP), SP $\leftarrow$ SP-2		
BS			2	2	MBS $\leftarrow$ (SP+1), RBS $\leftarrow$ (SP), SP $\leftarrow$ SP+2			
<b>Interrupt Control</b>	EI		2	2	IME (IPS.3) $\leftarrow$ 1			
		IE <sub>xxx</sub>	2	2	IE <sub>xxx</sub> $\leftarrow$ 1			
	DI		2	2	IME (IPS.3) $\leftarrow$ 0			
		IE <sub>xxx</sub>	2	2	IE <sub>xxx</sub> $\leftarrow$ 0			
<b>Input/Output</b>	IN*1	A, PORT <sub>n</sub>	2	2	A $\leftarrow$ PORT <sub>n</sub> (n=0-9, 12-14)			
		XA, PORT <sub>n</sub>	2	2	XA $\leftarrow$ PORT <sub>n+1</sub> , PORT <sub>n</sub> (n=4, 6, 8, 12)			
	OUT*1	PORT <sub>n</sub> , A	2	2	PORT <sub>n</sub> $\leftarrow$ 4 (n=2-9, 12-14)			
		PORT <sub>n</sub> , XA	2	2	PORT <sub>n+1</sub> , PORT <sub>n</sub> $\leftarrow$ XA (n=4, 6, 8, 12)			
<b>CPU Control</b>	HALT		2	2	Set HALT Mode (PCC.2 $\leftarrow$ 1)			
	STOP		2	2	Set STOP Mode (PCC.3 $\leftarrow$ 1)			
	NOP		1	1	No Operation			
<b>Special</b>	SEL	RB <sub>n</sub>	2	2	RBS $\leftarrow$ n (n=0-3)			
		MB <sub>n</sub>	2	2	MBS $\leftarrow$ n (n=0, 1, 15)			
	GETI*2	taddr	1	3	<ul style="list-style-type: none"> <li>TBR Instruction PC<sub>13-0</sub><math>\leftarrow</math>(taddr)<sub>4-0</sub>+(taddr+1)</li> <li>TCALL Instruction (SP-4)(SP-1)(SP-2)<math>\leftarrow</math>PC<sub>11-0</sub> (SP-3)<math>\leftarrow</math>MBE, RBE, PC<sub>13, 12</sub> PC<sub>13-0</sub><math>\leftarrow</math>(taddr)<sub>5-0</sub>+(taddr+1) SP<math>\leftarrow</math>SP-4</li> <li>When not TBR and TCALL instructions, (taddr) and (taddr+1) instructions are executed.</li> </ul>	<b>*10</b>	Depends on the instruction referred to.	

\* 1: MBE=0 or 1 and MBS=15 must be set for execution of IN/OUT instruction.

2: TBR and TCALL instructions are assembler pseudo-instructions for GETI instruction table definition.

### 10. Mask Option Selection

The following mask options are available for the ★  
μPD75116(A).

Whether or not they should be incorporated can be selected.

#### (1) Pins

Pin	Mask Option
P120 to P123	Bit-wise pull-up resistor incorporation enable
P130 to P133	
P140 to P143	

#### (2) Power-on reset circuit and power-on flag (PONF)

One of the following three settings can be selected.

Mask Option Specification		Switch Selection (See Figure 8-1)		Internal Reset Signal (RES)
Power-on Reset Circuit	Power-on Flag (PONF)	SWA	SWB	
Incorporated	Incorporated	ON	ON	Generated automatically
Not incorporated	Incorporated	ON	OFF	Not generated automatically
Not incorporated	Not incorporated	OFF	OFF	————

## $\mu$ PD75112(A), 75116(A)

### 11. Electrical Specifications

#### Absolute Maximum Ratings

(Ta = 25 °C)

Parameter	Symbol	Test Conditions		Ratings	Unit
Power supply voltage	V <sub>DD</sub>			-0.3 to +7.0	V
Input voltage	V <sub>I1</sub>	Except for ports 12 to 14		-0.3 to V <sub>DD</sub> +0.3	V
		V <sub>I2</sub> *1	Ports 12 to 14	On-chip pull-up resistor	-0.3 to V <sub>DD</sub> +0.3
	Open drain			-0.3 to +13	V
Output voltage	V <sub>O</sub>			-0.3 to V <sub>DD</sub> +0.3	V
Output current high	I <sub>OH</sub>	1 pin	Peak value	-10	mA
			Effective value	-5	mA
		All pins	Peak value	-30	mA
			Effective value	-15	mA
Output current low	I <sub>OL</sub> *2	1 pin	Peak value	10	mA
			Effective value	5	mA
		Total current of ports 0, 2 to 4, 12 to 14	Peak value	50	mA
			Effective value	25	mA
			Peak value	50	mA
			Effective value	25	mA
Operation temperature	T <sub>opt</sub>			-40 to +85	°C
Storage temperature	T <sub>stg</sub>			-65 to +150	°C

\* 1: When applying a voltage larger than 10 V to ports 12, 13 and 14 each, set the power impedance (pull-up resistor) to 50 k $\Omega$  or more.

\* 2: Calculate each effective value using the following expression:

$$[\text{Effective value}] = [\text{Peak value}] \times \sqrt{\text{duty}}$$

**Note:** Product quality may suffer if the absolute maximum rating is exceeded for even a single parameter or even momentarily. That is, the absolute maximum ratings are rated values at which the product is on the verge of suffering physical damage, and therefore the product must be used under conditions which ensure that the absolute maximum ratings are not exceeded.

**Operating Voltage** ★  
(Ta = -40 to +85 °C)

Parameter	Test Conditions	MIN.	MAX.	Unit
CPU*1		*2	6.0	V
Programmable threshold port (comparator input)		4.5	6.0	V
Power-on reset circuit*3		4.5	6.0	V
Other hardware*1		2.7	6.0	V

- \*1: Except system clock oscillator, programmable threshold port and power-on reset circuit
- 2: Operating voltage range depends on the cycle time.  
See the **AC Characteristics**.
- 3: Whether or not it should be incorporated can be selected by mask options.  
See the **Power-On Reset Circuit Characteristics (Mask Option)**.

## μPD75112(A), 75116(A)

### Oscillate Characteristics

( $T_a = -40$  to  $+85$  °C,  $V_{DD} = 2.7$  to  $6.0$  V)

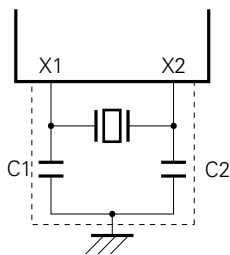
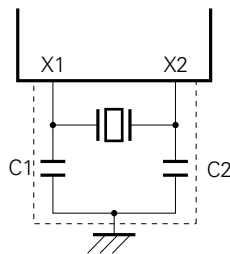
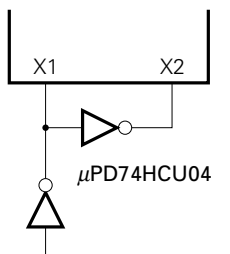
Oscillator	Recommended Constant	Parameter	Test Condition	MIN.	TYP.	MAX.	Unit
Ceramic oscillation		Oscillator frequency ( $f_{xx}$ )*1	$V_{DD}$ = oscillation voltage range	2.0		5.0*3	MHz
		Oscillation stabilizing time*2	Oscillation voltage range MIN.	4			ms
Crystal oscillator		Oscillator frequency ( $f_{xx}$ )*1		2.0	4.19	5.0*3	MHz
		Oscillation stabilizing time*2	$V_{DD} = 4.5$ to $6.0$ V	10			ms
				30			ms
External clock		X1 input frequency ( $f_x$ )*1		2.0		5.0*3	MHz
		X1 input high and low level widths ( $t_{XH}$ , $t_{XL}$ )		100		250	ns

\*1: Oscillator frequency and X1 input frequency indicate only characteristics of the oscillator. Refer to AC characteristics for the instruction execution time.

2: The oscillation stabilizing time is necessary for oscillation to stabilize after  $V_{DD}$  reaches oscillation voltage range MIN. or the STOP mode is released.

★ 3: When the oscillator frequency is  $4.19 \text{ MHz} < f_{xx} \leq 5.0 \text{ MHz}$ , PCC=0011 should not be selected as instruction execution time. If PCC=0011 is selected, 1 machine cycle becomes less than  $0.95 \mu\text{s}$ , with the result that the specified MIN. value of  $0.95 \mu\text{s}$  cannot be observed.

**Note:** When using the main system clock oscillator, wiring in the area enclosed with the dotted line should be carried out as follows to avoid an adverse effect from wiring capacitance. ★

- Wiring should be as short as possible.
- Wiring should not cross other signal lines.
- Wiring should not be placed close to a varying high current.
- The potential of the oscillator capacitor ground should be the same as  $V_{SS}$ . Do not ground wiring to a ground pattern in which a high current flows.
- Do not fetch a signal from the oscillator.



### DC Characteristics

(Ta = -40 to +85 °C, VDD = 2.7 to 6.0 V)

Parameter	Symbol	Test Conditions		MIN.	TYP.	MAX.	Unit
Input voltage high	V <sub>IH1</sub>	Except for ports listed below		0.7V <sub>DD</sub>		V <sub>DD</sub>	V
	V <sub>IH2</sub>	Ports 0, 1, T10, 1, RESET		0.8V <sub>DD</sub>		V <sub>DD</sub>	V
	V <sub>IH3</sub>	Ports 12 to 14	On-chip pull-up-resistor	0.7V <sub>DD</sub>		V <sub>DD</sub>	V
			Open drain	0.7V <sub>DD</sub>		12	V
V <sub>IH4</sub>	X1, X2		V <sub>DD</sub> -0.5		V <sub>DD</sub>	V	
Input voltage low	V <sub>IL1</sub>	Except for ports listed below		0		0.3V <sub>DD</sub>	V
	V <sub>IL2</sub>	Ports 0, 1, T10, 1, RESET		0		0.2V <sub>DD</sub>	V
	V <sub>IL3</sub>	X1, X2		0		0.4	V
Output voltage high	V <sub>OH</sub>	V <sub>DD</sub> = 4.5 to 6.0 V, I <sub>OH</sub> = -1 mA		V <sub>DD</sub> -1.0			V
		I <sub>OH</sub> = -100μA		V <sub>DD</sub> -0.5			V
Output voltage low	V <sub>OL</sub>	V <sub>DD</sub> = 4.5 to 6.0 V	Ports 0, 2 to 9, I <sub>OL</sub> = 5 mA		0.25	1.0	V
			Ports 12 to 14, I <sub>OL</sub> = 5 mA		0.40	1.0	V
	V <sub>DD</sub> = 4.5 to 6.0V, I <sub>OL</sub> = 1.6 mA					0.4	V
	I <sub>OL</sub> = 400μA					0.5	V
Input leakage current high	I <sub>LIH1</sub>	V <sub>IN</sub> = V <sub>DD</sub>	Except for ports listed below			3	μA
			X1, X2			20	μA
	I <sub>LIH3</sub>	V <sub>IN</sub> = 12 V	Ports 12 to 14 (for open drain)			20	μA
Input leakage current low	I <sub>LIL1</sub>	V <sub>IN</sub> = 0 V	Except for X1, X2			-3	μA
			X1, X2			-20	μA
Output leakage current high	I <sub>LOH1</sub>	V <sub>OUT</sub> = V <sub>DD</sub>	Except for ports listed below			3	μA
			Ports 12 to 14 (for open drain)			20	μA
Output leakage current low	I <sub>LOL</sub>	V <sub>OUT</sub> = 0 V				-3	μA
On-chip pull-up resistor	R <sub>L</sub>	Ports 12 to 14	V <sub>DD</sub> =5 V ±10%	15	40	70	kΩ
				10		80	kΩ
Supply current*1	I <sub>DD1</sub>	4.19 MHz crystal oscillation C1 = C2 = 22 pF	V <sub>DD</sub> =5 V ±10%*2		3	9	mA
			V <sub>DD</sub> =3 V ±10%*3		0.55	1.5	mA
	I <sub>DD2</sub>		HALT mode	V <sub>DD</sub> =5 V ±10%	600	1800	μA
				V <sub>DD</sub> =3 V ±10%	200	600	μA
I <sub>DD3</sub>	STOP mode, V <sub>DD</sub> = 3 V ±10%			0.1	10	μA	

\*1: Current for the on-chip pull-up resistor, power-on reset circuit (mask option) and comparator circuit is not included.  
2: When operated in the high-speed mode with the processor clock

control resistor (PCC) set tp 0011.  
3: When operated in the low-speed mode with the PCC set to 0000.

## $\mu$ PD75112(A), 75116(A)

### Capacitance

( $T_a = 25\text{ }^\circ\text{C}$ ,  $V_{DD} = 0\text{ V}$ )

Parameter	Symbol	Test Conditions	MIN.	TYP.	MAX.	Unit
Input capacitance	$C_{IN}$	f = 1 MHz 0 V for pins except the measured pins			15	pF
Output capacitance	$C_{OUT}$				15	pF
Input/output capacitance	$C_{IO}$				15	pF

### Comparator Characteristics

( $T_a = -40\text{ to }+85\text{ }^\circ\text{C}$ ,  $V_{DD} = 4.5\text{ to }6.0\text{ V}$ )

Parameter	Symbol	Test Conditions	MIN.	TYP.	MAX.	Unit
Comparison accuracy	$V_{ACOMP}$				$\pm 100$	mV
Threshold voltage	$V_{TH}$		0		$V_{DD}$	V
PTH input voltage	$V_{IPTH}$		0		$V_{DD}$	V
Comparator circuit consumption		Set PTHM7 to "1".		1		mA

### Power-On Reset Circuit Characteristics (Mask Option)

( $T_a = -40\text{ to }+85\text{ }^\circ\text{C}$ )

Parameter	Symbol	Test Conditions	MIN.	TYP.	MAX.	Unit
Power-on reset operating voltage high	$V_{DDH}$		4.5		6.0	V
Power-on reset operating voltage low	$V_{DDL}$		0		0.2	V
Supply voltage rise time	$t_r$		10		*1	$\mu\text{s}$
Supply voltage off time	$t_{off}$		1			s
Power-on reset circuit current consumption*2	$I_{DDPR}$	$V_{DD} = 5\text{ V} \pm 10\%$		10	100	$\mu\text{A}$
		$V_{DD} = 2.5\text{ V}$		2	20	$\mu\text{A}$

\*1:  $2^{17}/f_{XX}$  (31.3 ms when  $f_{XX} = 4.19\text{ MHz}$ )

\*2: Current flow upon power-on reset or with an on-chip power-on flag

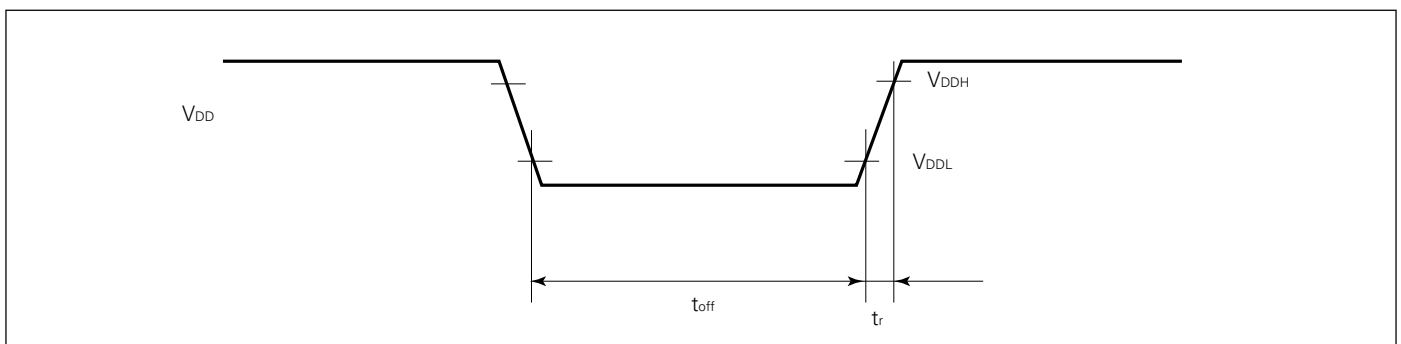

**Note:** Start the power supply smoothly.

### AC Characteristics

(Ta = -40 to +85 °C, VDD = 2.7 to 6.0 V)

Parameter	Symbol	Test Conditions	MIN.	TYP.	MAX.	Unit
CPU clock cycle time* (min. instruction execution time = 1 machine cycle)	tcy	VDD = 4.5 to 6.0 V	0.95		32	μs
			3.8		32	μs
TIO, T11 input frequency	fTI	VDD = 4.5 to 6.0 V	0		1	MHz
			0		275	kHz
TIO, T11 input high and low-level widths	tTIH, tTIL	VDD = 4.5 to 6.0 V	0.48			μs
			1.8			μs
SCK cycle time	tkcy	VDD = 4.5 to 6.0 V	Input	0.8		μs
			Output	0.95		μs
			Input	3.2		μs
			Output	3.8		μs
SCK high and low-level widths	tkH, tkL	VDD = 4.5 to 6.0 V	Input	0.4		μs
			Output	tkcy/2-50		ns
			Input	1.6		μs
			Output	tkcy/2-50		ns
SI setup time (to SCK↑)	tSIK		100			ns
SI hold time (from SCK↑)	tKSI		400			ns
S0 output delay time from SCK↓	tkSO	VDD = 4.5 to 6.0 V			300	ns
					1000	ns
INT0 to INT4 High and low-level widths	tINTH, tINTL		5			μs
RESET low-level width	tRSL		5			μs

## $\mu$ PD75112(A), 75116(A)

\*: The cycle time of the CPU clock ( $\Phi$ ) is determined by the input frequency of the ceramic crystal oscillator and the setting of the processor clock control register (PCC). The cycle time ( $t_{CY}$ ) for  $V_{DD}$  is shown below.

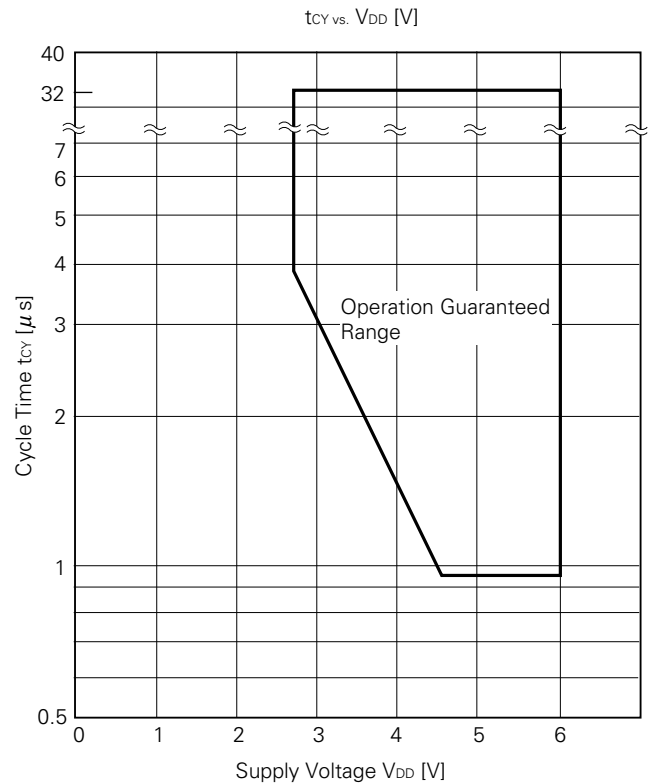

### AC Timing Test Point (Except for Ports 0, 1, T10, T11, X1, X2 and RESET)

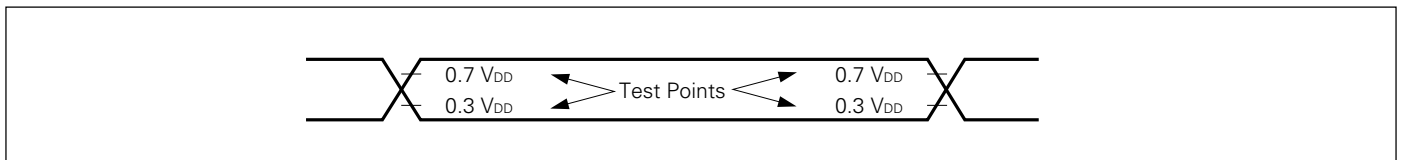

### Clock Timing

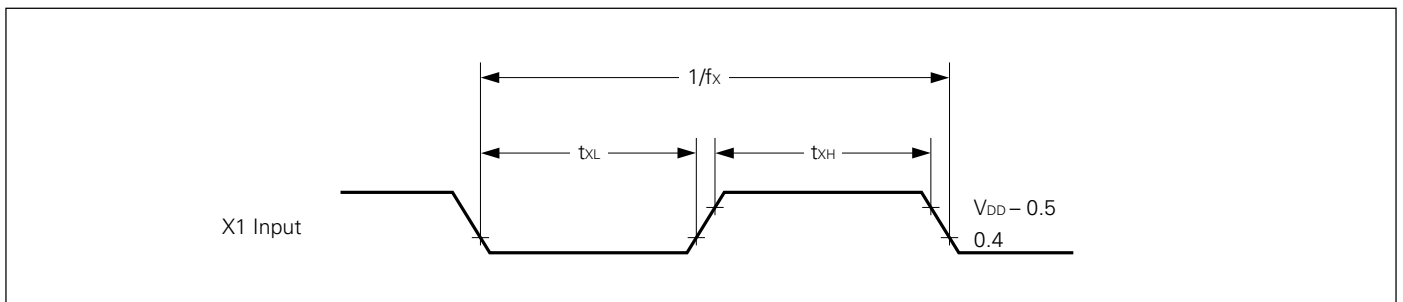

### T10 and T11 Input Timing

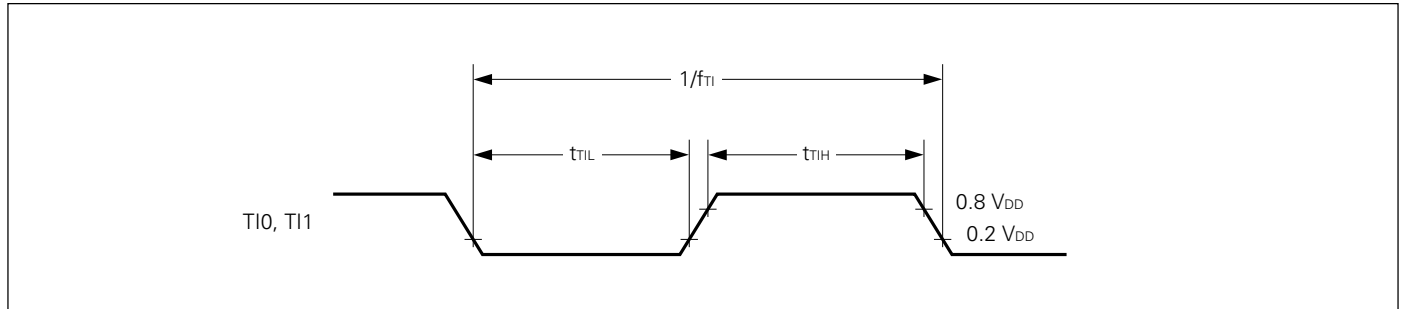

### Serial Transfer Timing

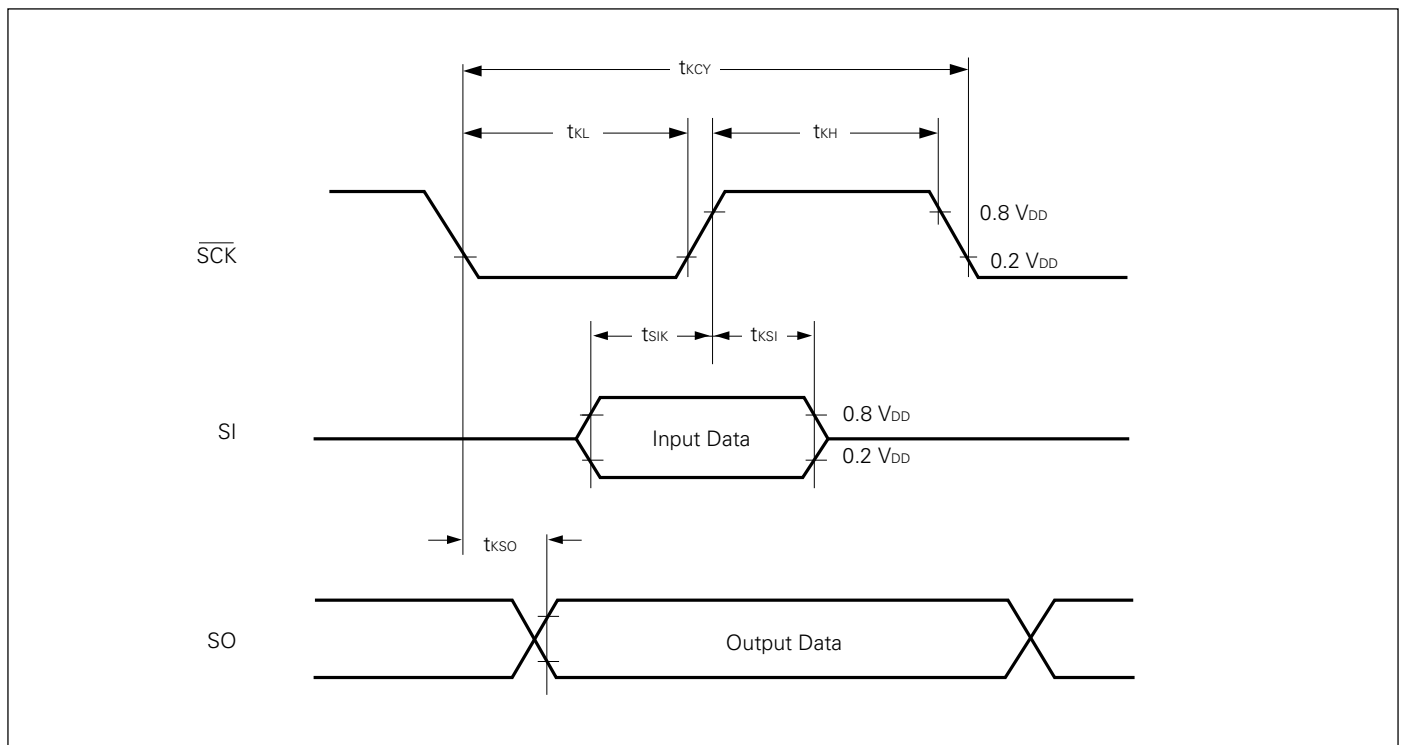

### Interrupt Input Timing

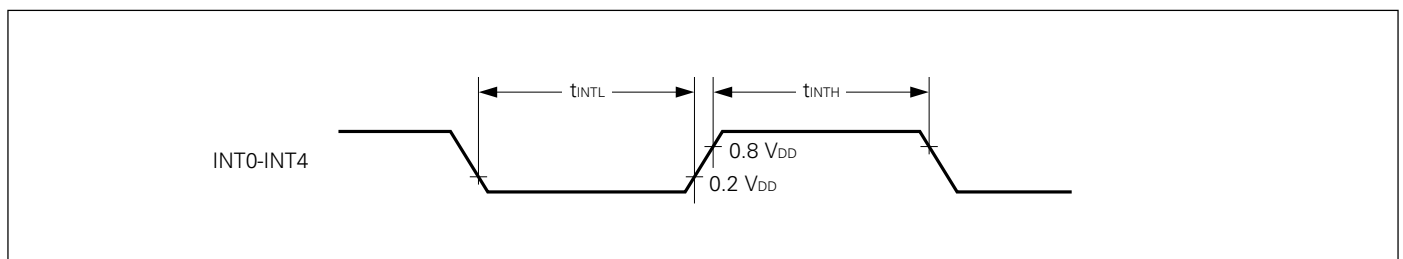

## $\mu$ PD75112(A), 75116(A)

### RESET Input Timing

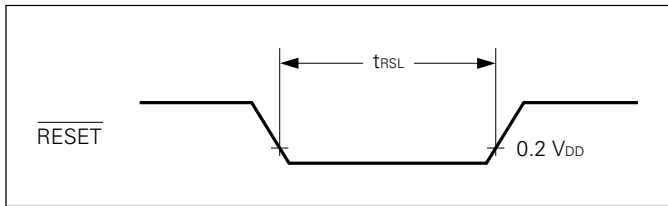

### Data Memory STOP Mode Low Supply Voltage Data Retention Characteristics

( $T_a = -40$  to  $+85$  °C)

Parameter	Symbol	Test Conditions	MIN.	TYP.	MAX.	Unit
Data retention supply voltage	$V_{\text{DDDR}}$		2.0		6.0	V
Data retention supply current*1	$V_{\text{DDDR}}$	$V_{\text{DDDR}} = 2.0$ V		0.1	10	$\mu\text{A}$
Release signal set time	$t_{\text{SREL}}$		0			$\mu\text{s}$
Oscillation stabilization wait time*2	$t_{\text{WAIT}}$	Release by $\overline{\text{RESET}}$		$2^{17}/f_x$		ms
		Release by interrupt request		*3		ms

\* 1: Current for the on-chip pull-up resistor, power-on circuit (mask option) and comparator circuit is not included.

\* 2: The oscillation stabilizing time is intended to stop the CPU to prevent any unstable operation at the start of oscillation.

\* 3: Depends on the following setting of the basic interval timer mode register (BTM).

BTM3	BTM2	BTM1	BTM0	Wait Time ( $f_{\text{xx}}=4.19$ MHz Valu's in Parentheses)
—	0	0	0	$2^{20}/f_{\text{xx}}$ (approx. 250 ms)
—	0	1	1	$2^{17}/f_{\text{xx}}$ (approx. 31.3 ms)
—	1	0	1	$2^{15}/f_{\text{xx}}$ (approx. 7.82 ms)
—	1	1	1	$2^{13}/f_{\text{xx}}$ (approx. 1.95 ms)

### Data Retention Timing (STOP Mode Release by $\overline{\text{RESET}}$ )

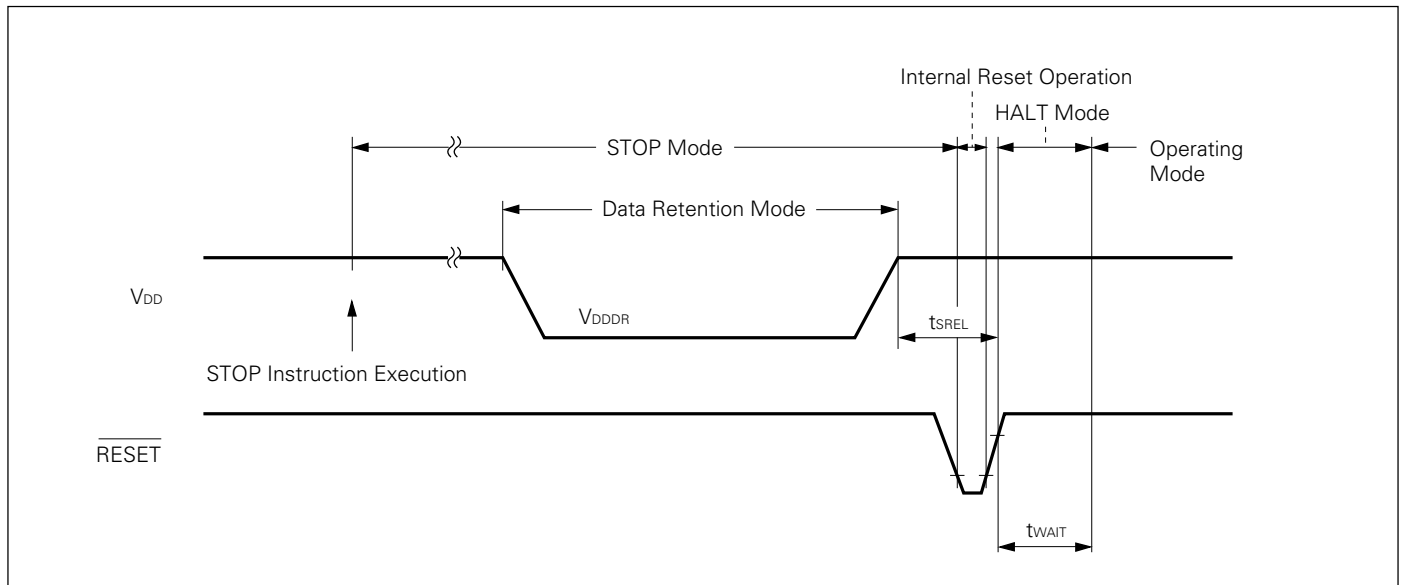

### Data Retention Timing (Standby Release Signal: STOP Mode Release by Interrupt Signal)

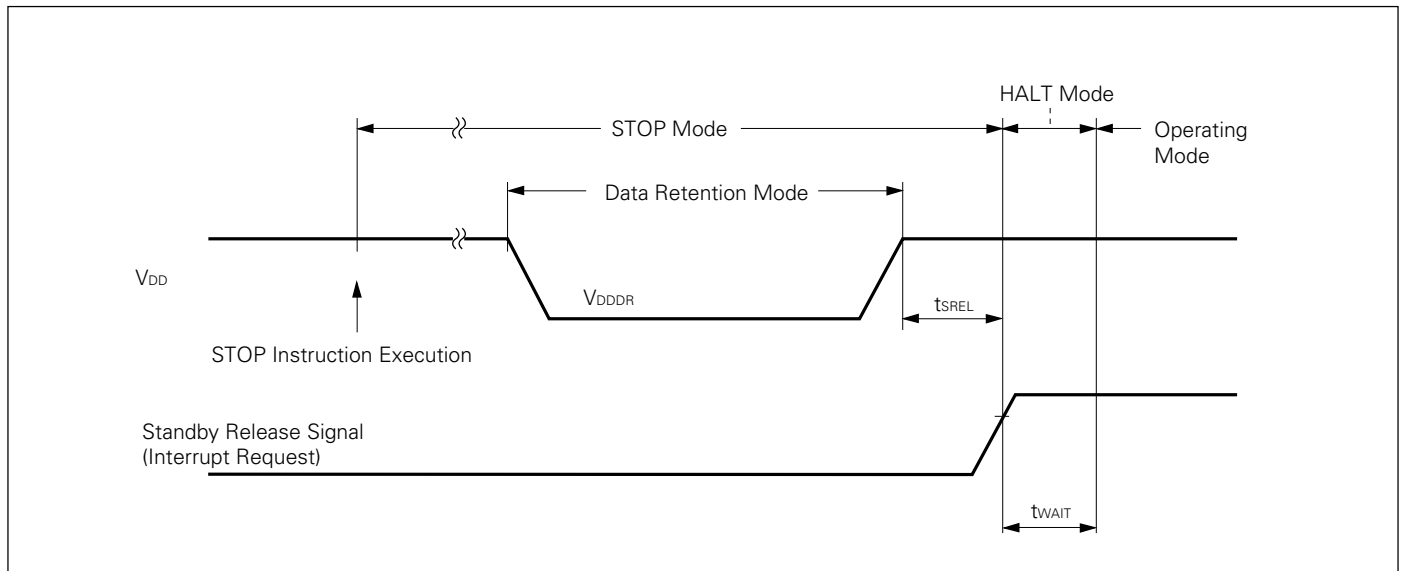

## $\mu$ PD75112(A), 75116(A)

### 12. Packing Information

#### 64 PIN PLASTIC SHRINK DIP (750 mil)

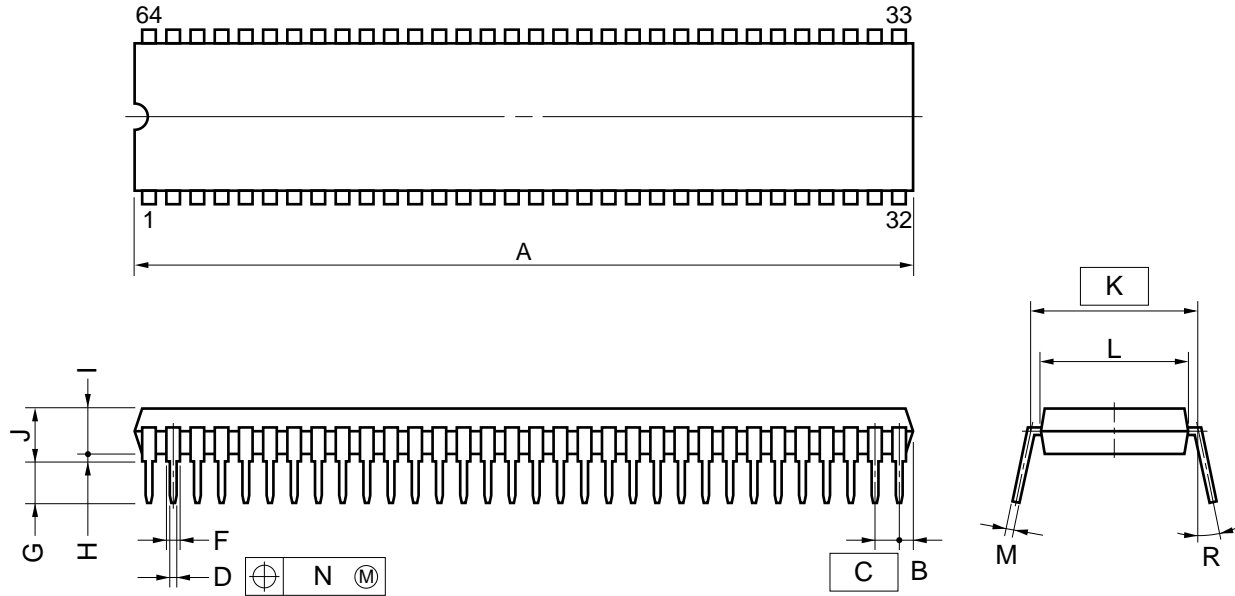

#### NOTE

- 1) Each lead centerline is located within 0.17 mm (0.007 inch) of its true position (T.P.) at maximum material condition.
- 2) Item "K" to center of leads when formed parallel.

ITEM	MILLIMETERS	INCHES
A	58.68 MAX.	2.311 MAX.
B	1.78 MAX.	0.070 MAX.
C	1.778 (T.P.)	0.070 (T.P.)
D	0.50±0.10	0.020 <sup>+0.004</sup> <sub>-0.005</sub>
F	0.9 MIN.	0.035 MIN.
G	3.2±0.3	0.126±0.012
H	0.51 MIN.	0.020 MIN.
I	4.31 MAX.	0.170 MAX.
J	5.08 MAX.	0.200 MAX.
K	19.05 (T.P.)	0.750 (T.P.)
L	17.0	0.669
M	0.25 <sup>+0.10</sup> <sub>-0.05</sub>	0.010 <sup>+0.004</sup> <sub>-0.003</sub>
N	0.17	0.007
R	0~15°	0~15°

P64C-70-750A,C-1



### 64-Pin Plastic QFP (14 × 20) (Unit: mm) ★

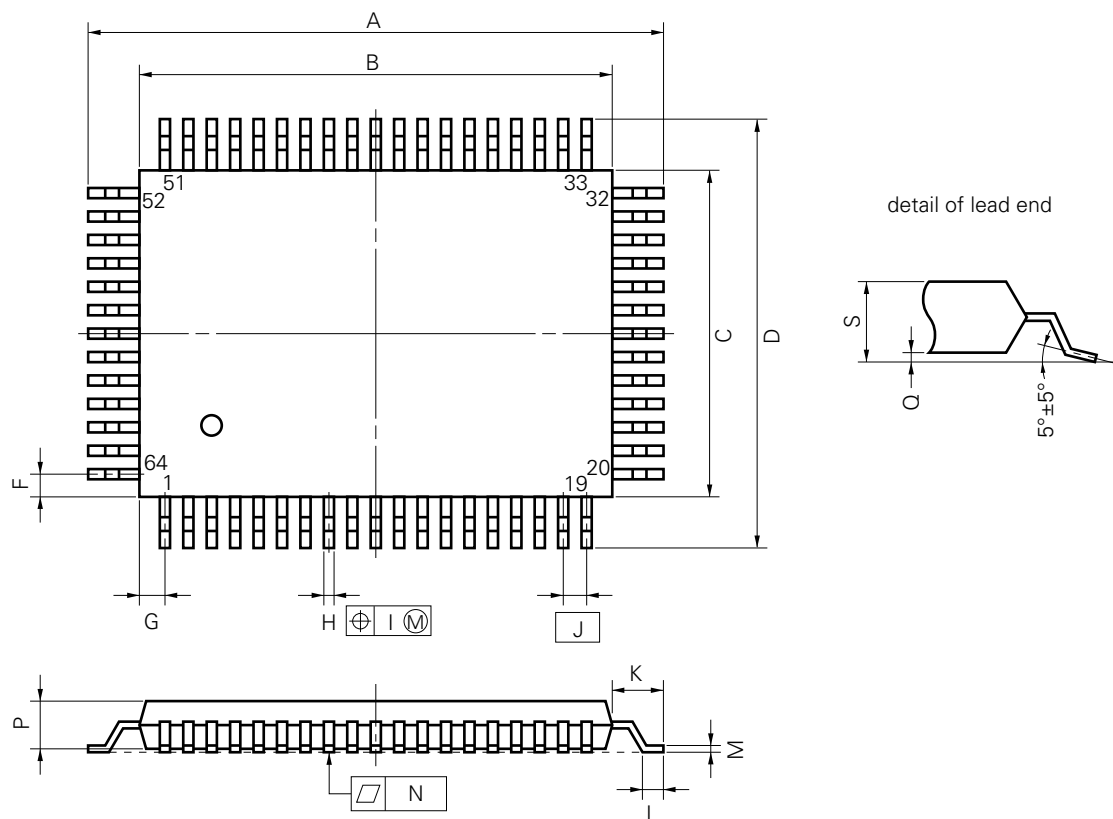

P64GF-100-3B8,3BE,3BR-1

#### NOTE

Each lead centerline is located within 0.20 mm (0.008 inch) of its true position (T.P.) at maximum material condition.

ITEM	MILLIMETERS	INCHES
A	23.6±0.4	0.929±0.016
B	20.0±0.2	0.795 <sup>+0.009</sup> <sub>-0.008</sub>
C	14.0±0.2	0.551 <sup>+0.009</sup> <sub>-0.008</sub>
D	17.6±0.4	0.693±0.016
F	1.0	0.039
G	1.0	0.039
H	0.40±0.10	0.016 <sup>+0.004</sup> <sub>-0.005</sub>
I	0.20	0.008
J	1.0 (T.P.)	0.039 (T.P.)
K	1.8±0.2	0.071 <sup>+0.008</sup> <sub>-0.009</sub>
L	0.8±0.2	0.031 <sup>+0.009</sup> <sub>-0.008</sub>
M	0.15 <sup>+0.10</sup> <sub>-0.05</sub>	0.006 <sup>+0.004</sup> <sub>-0.003</sub>
N	0.12	0.005
P	2.7	0.106
Q	0.1±0.1	0.004±0.004
S	3.0 MAX.	0.119 MAX.

## $\mu$ PD75112(A), 75116(A)

64-Pin Ceramic QFP for ES (Reference Drawing) (Unit: mm)

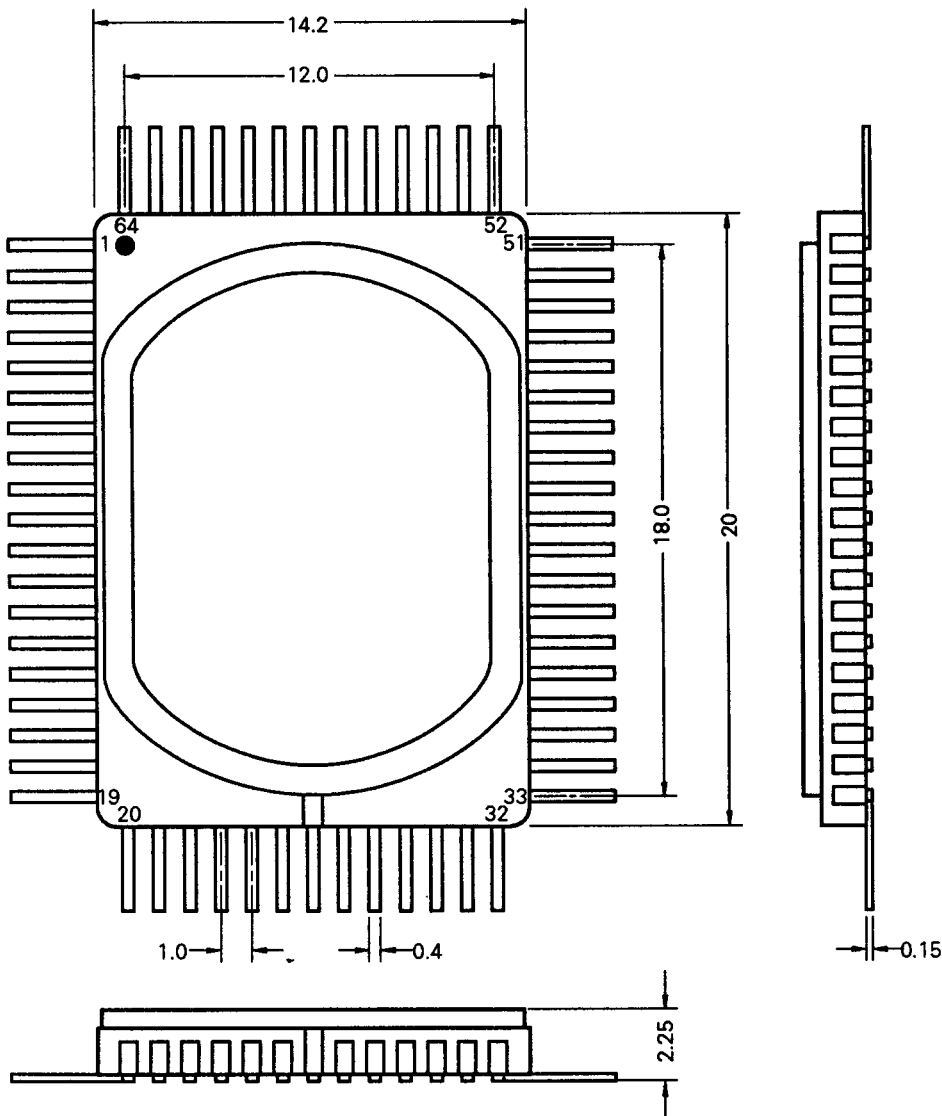

### Cautions

- 1: The metal cap is connected to pin 26 and is set to Vss (GND) level.
- 2: The lead wire at the bottom is formed diagonally.
- 3: Since the cutting treatment of the lead wire edge is not under process control, the lead lengths are not specified.

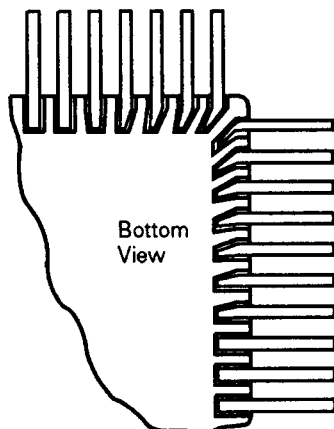

### 13. Recommended Soldering Conditions ★

The μPD75112(A) and 75116(A) should be soldered and mounted under the conditions recommended in the table below.

For detail of recommended soldering conditions, refer to the information document “**Surface Mount Technology Manual**” (IEI-1207).

For soldering methods and conditions other than those recommended below, contact our sales personnel.

**Table 13-1 Surface Mounting Type Soldering Conditions**

μPD75112GF(A)-xxx-3BE : 64-pin plastic QFP (14 × 20mm)  
 μPD75116GF(A)-xxx-3BE : 64-pin plastic QFP (14 × 20mm)

Soldering Method	Soldering Conditions	Recommended Condition Symbol
Infrared reflow	Package peak temperature: 230 °C Duration: 30 sec. max. (at 210°C above) Number of times: Once	IR30-00-1
VPS	Package peak temperature: 215 °C Duration: 40 sec. max. (at 200°C above) Number of times: Once	VP15-00-1
Wave soldering	Solder bath temperature: 260 °C max. Duration: 10 sec. max. Number of times: Once Preliminary heat temperature: 120 °C max. (Package surface temperature)	WS60-00-1
Pin part heating	Pin part temperature: 300 °C max. Duration: 3 sec. max. (per device side)	—

**Note: Use more than one soldering method should be avoided (except in the case of pin part).**

**Table 13-2 Insertion Type Soldering Conditions**

μPD75112CW(A)-xxx: 64-pin plastic shrink DIP (750 mil)  
 μPD75116CW(A)-xxx: 64-pin plastic shrink DIP (750 mil)

Soldering Method	Soldering Conditions
Wave soldering (lead part only)	Solder bath temperature: 260 °C max. Duration: 10 sec. max.
Pin part heating	Pin part temperature: 260 °C max. Duration: 10 sec. max.

**Note: Wave soldering is only for the lead part in order that jet solder can not contact with the chip.**

#### Notice

**A version of this product with improved recommended soldering conditions is available. For details (improvements such as infrared reflow peak temperature extension (235 °C, number of times: twice, relaxation of time limit), contact NEC sales**

## μPD75112(A), 75116(A)

### ★ APPENDIX A. Differences between μPD751××(A) Series Products and Related PROM Products

Product Name		μPD75104(A)	μPD75106(A)	μPD75108(A)	μPD75112(A)	μPD75116(A)	μPD75P108B	μPD75P116	
ROM Configuration		Mask ROM					PROM		
ROM (bit)		0000H to 0FFFH 4096 × 8	0000H to 177FH 6016 × 8	0000H to 1F7FH 8064 × 8	0000H to 2F7FH 12160 × 8	0000H to 3F7FH 16256 × 8	0000H to 1F7FH 8064 × 8	0000H to 3F7FH 16256 × 8	
RAM (bit)		320 × 4 Bank 0: 256 × 4 Bank 1: 64 × 4		512 × 4 Bank 0: 256 × 4 Bank 1: 256 × 4			512 × 4 Bank 0: 256 × 4 Bank 1: 256 × 4		
Instruction set		High end (Only μPD75104(A) does not incorporate BR !addr instruction).					High end		
I/O line	Total	58							
	Input/output	<ul style="list-style-type: none"> <li>• CMOS input/output: 32</li> <li>• +12 V withstand N-ch voltage open-drain input/output: 12 (Pull-up resistor can be on-chip by mask option.)</li> </ul>					<ul style="list-style-type: none"> <li>• CMOS input/output: 32</li> <li>• +12 V withstand N-ch open-drain input/output: 12</li> <li>Each pin can directly drive LED: 44</li> </ul>		
	Input	<ul style="list-style-type: none"> <li>• CMOS input/output: 10</li> <li>• Comparator: 4</li> </ul>							
Power-on reset circuit		Can be on-chip by mask option					None		
Power-on flag									
Supply voltage range		2.7 to 6.0 V					2.7 to 6.0 V	5 V±10%	
Pin connection		Differs depending on package					Differs depending on package (with V <sub>PP</sub> pin)		
Quality grade		Special					Standard		
Package		<ul style="list-style-type: none"> <li>• 64-pin plastic shrink DIP (750 mil)</li> <li>• 64-pin plastic QFP (14 × 20 mm)</li> </ul>				<ul style="list-style-type: none"> <li>• 64-pin plastic shrink DIP (750 mil)</li> <li>• 64-pin ceramic shrink DIP (with window)</li> <li>• 64-pin plastic QFP (14 × 20 mm)</li> </ul>		<ul style="list-style-type: none"> <li>• 64-pin plastic shrink DIP (750 mil)</li> <li>• 64-pin plastic QFP (14 × 20 mm)</li> </ul>	

### APPENDIX B. Development Tools

The following tools are available for the development of systems for which the μPD75116(A) is used.

Hardware	IE-75000-R*1 IE-75001-R	75X series in-circuit emulator
	IE-75000-R-EM*2	Emulation board for IE-75000R and IE-75001-R.
	EP-75108CW-R	Emulation probe for μPD75112CW(A) and 75116CW(A).
	EP-75108GF-R EV-9200G64	Emulation probe for μPD75112GF(A) and 75116GF(A). 64-pin conversion socket EV-9200G64 added.
	PG-1500	PROM programmer
	PA-75P108CW	μPD75P116CW PROM programmer adapter connected to PG-1500
	PA-75P116GF	μPD75P116GF PROM programmer adapter connected to PG-1500
Software	IE control program	Host machine <ul style="list-style-type: none"> <li>• PC-9800 series (MS-DOS™ Ver. 3.30 to 5.00A*3)</li> <li>• IBM PC/AT™ (PC DOS™ Ver. 3.1)</li> </ul>
	PG-1500 controller	
	RA75X relocatable assembler	

\* 1: Maintenance product

2: Not incorporated in the IE-75001-R.

3: The task swap function, which is provided with Ver. 5.00/5.00A, is not available with this software.

**Remarks:** For development tools manufactured by a third party, see the “75X Series Selection Guide” (IF-151)“.

## μPD75112(A), 75116(A)

### ★ APPENDIX C. Related Documentations

#### List of Device Related Documentations

Document Name		Document Number
User's Manual		IEM-1260
Instruction Application Table		—
Application Note	(I) Introductory Volume	IEM-1139
	(II) Remote Control Reception Volume	IEM-1281
	(III) Bar-Code Reader Volume	IEM-1265
	(IV) IC Control for MSK Transmission/Reception Volume	IEA-1278
75X Series Selection Guide		IF-1027

#### List of Development Tools Related Documentations

Document Name		Document Number	
Hardware	IE-75000-R/IE-75001-R User's Manual	EEU-1416	
	IE-75000-R-EM User's Manual	EEU-1294	
	EP-75108CW-R User's Manual	EEU-1308	
	EP-75108GF-R User's Manual	EEU-1318	
	PG-1500 User's Manual	EEU-1335	
Software	RA75X Assembler Package User's Manual	Operation Volume	EEU-1346
		Language Volume	EEU-1343
	PG-1500 Controller User's Manual		EEU-1291

#### List of Other Related Documentations

Document Name	Document Number
Package Manual	IEI-1213
Surface Mount Technology Manual	IEI-1207
Quality Grade on NEC Semiconductor Devices	IEI-1209
NEC Semiconductor Device Reliability & Quality Control	—
Electrostatic Discharge (ESD) Test	—
Semiconductor Devices Quality Guarantee Guide	MEI-1202
Microcomputer Related Products Guide Other Manufactures Volume	—

**Note: The contents of the above related documents are subject to change without notice. The latest documents should be used for design, etc.**



No part of this document may be copied or reproduced in any form or by any means without the prior written consent of NEC Corporation. NEC Corporation assumes no responsibility for any errors which may appear in this document.

NEC Corporation does not assume any liability for infringement of patents, copyrights or other intellectual property rights of third parties by or arising from use of a device described herein or any other liability arising from use of such device. No license, either express, implied or otherwise, is granted under any patents, copyrights or other intellectual property rights of NEC Corporation or others.

The devices listed in this document are not suitable for use in aerospace equipment, submarine cables, nuclear reactor control systems and life support systems. If customers intend to use NEC devices for above applications or they intend to use "Standard" quality grade NEC devices for applications not intended by NEC, please contact our sales people in advance.

Application examples recommended by NEC Corporation

Standard: Computer, Office equipment, Communication equipment, Test and Measurement equipment, Machine tools, Industrial robots, Audio and Visual equipment, Other consumer products, etc.

Special: Automotive and Transportation equipment, Traffic control systems, Antidisaster systems, Anticrime systems, etc.

M4 92.6

MS-DOS is a trademark of Microsoft Corporation.  
PC/AT and PC DOS are trademarks of IBM Corporations.