

### FEATURES

- Excellent Noise Performance:  $950 \text{ pV}/\sqrt{\text{Hz}}$  or 1.5 dB Noise Figure
- Ultralow THD:  $< 0.01\%$  @  $G = 100$  Over the Full Audio Band
- Wide Bandwidth: 1 MHz @  $G = 100$
- High Slew Rate:  $17 \text{ V}/\mu\text{s}$  typ
- Unity Gain Stable
- True Differential Inputs
- Subaudio 1/f Noise Corner
- 8-Pin Mini-DIP with Only One External Component Required
- Very Low Cost
- Extended Temperature Range:  $-40^\circ\text{C}$  to  $+85^\circ\text{C}$

### APPLICATIONS

- Audio Mix Consoles
- Intercom/Paging Systems
- Two-Way Radio
- Sonar
- Digital Audio Systems

### GENERAL DESCRIPTION

The SSM2017 is a latest generation audio preamplifier combining SSM preamplifier design expertise with advanced processing. The result is excellent audio performance from a self-contained 8-pin mini-DIP device, requiring only one external gain set resistor or potentiometer. The SSM2017 is further enhanced by its unity gain stability.

Key specifications include ultralow noise (1.5 dB noise figure) and THD ( $< 0.01\%$  at  $G = 100$ ), complemented by wide bandwidth and high slew rate.

Applications for this low cost device include microphone preamplifiers and bus summing amplifiers in professional and consumer audio equipment, sonar, and other applications requiring a low noise instrumentation amplifier with high gain capability.

### FUNCTIONAL BLOCK DIAGRAM

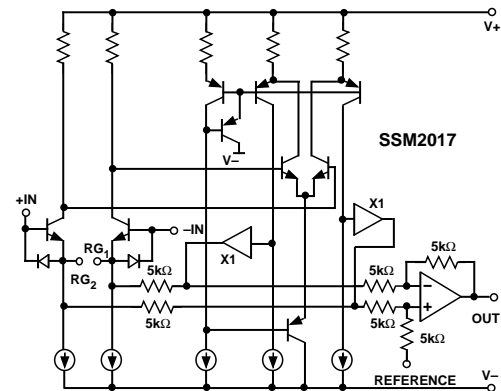

### PIN CONNECTIONS

#### Epoxy Mini-DIP (P Suffix)

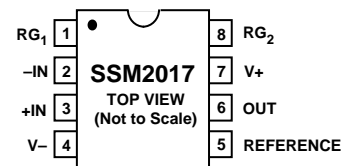

#### 16-Pin Wide Body SOL (S Suffix)

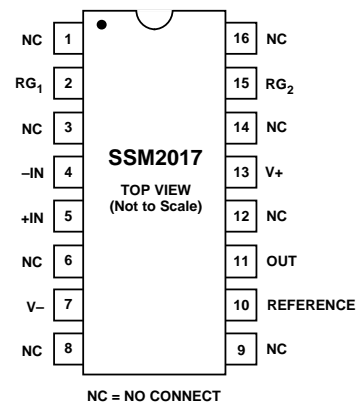

### REV. B

Information furnished by Analog Devices is believed to be accurate and reliable. However, no responsibility is assumed by Analog Devices for its use, nor for any infringements of patents or other rights of third parties which may result from its use. No license is granted by implication or otherwise under any patent or patent rights of Analog Devices.

# SSM2017–SPECIFICATIONS ( $V_S = \pm 15\text{ V}$ and $-40^\circ\text{C} \leq T_A \leq +85^\circ\text{C}$ , unless otherwise noted. Typical specifications apply at $T_A = +25^\circ\text{C}$ .)

Parameter	Symbol	Conditions	Min	Typ	Max	Units
<b>DISTORTION PERFORMANCE</b>						
Total Harmonic Distortion Plus Noise	THD+N	$T_A = +25^\circ\text{C}$ $V_O = 7\text{ V rms}$ $R_L = 5\text{ k}\Omega$ $G = 1000, f = 1\text{ kHz}$ $G = 100, f = 1\text{ kHz}$ $G = 10, f = 1\text{ kHz}$ $G = 1, f = 1\text{ kHz}$		0.012 0.005 0.004 0.008		% % % %
<b>NOISE PERFORMANCE</b>						
Input Referred Voltage Noise Density	$e_n$	$f = 1\text{ kHz}, G = 1000$ $f = 1\text{ kHz}; G = 100$ $f = 1\text{ kHz}; G = 10$		0.95 1.95 11.83		$\text{nV}/\sqrt{\text{Hz}}$ $\text{nV}/\sqrt{\text{Hz}}$ $\text{nV}/\sqrt{\text{Hz}}$
Input Current Noise Density	$i_n$	$f = 1\text{ kHz}; G = 1$ $f = 1\text{ kHz}, G = 1000$		107.14 2		$\text{nV}/\sqrt{\text{Hz}}$ $\text{pA}/\sqrt{\text{Hz}}$
<b>DYNAMIC RESPONSE</b>						
Slew Rate	SR	$G = 10$ $R_L = 4.7\text{ k}\Omega$ $C_L = 50\text{ pF}$ $T_A = +25^\circ\text{C}$	10	17		$\text{V}/\mu\text{s}$
Small Signal Bandwidth	$BW_{-3\text{ dB}}$	$G = 1000$ $G = 100$ $G = 10$ $G = 1$		200 1000 2000 4000		$\text{kHz}$ $\text{kHz}$ $\text{kHz}$ $\text{kHz}$
<b>INPUT</b>						
Input Offset Voltage	$V_{\text{IOS}}$			0.1	1.2	mV
Input Bias Current	$I_B$	$V_{\text{CM}} = 0\text{ V}$		6	25	$\mu\text{A}$
Input Offset Current	$I_{\text{OS}}$	$V_{\text{CM}} = 0\text{ V}$		$\pm 0.002$	$\pm 2.5$	$\mu\text{A}$
Common-Mode Rejection	CMR	$V_{\text{CM}} = \pm 8\text{ V}$ $G = 1000$ $G = 100$ $G = 10$ $G = 1, T_A = +25^\circ\text{C}$ $G = 1, T_A = -40^\circ\text{C to } +85^\circ\text{C}$	80 60 40 26 20	112 92 74 54 54		dB dB dB dB dB
Power Supply Rejection	PSR	$V_S = \pm 6\text{ V to } \pm 18\text{ V}$ $G = 1000$ $G = 100$ $G = 10$ $G = 1$	80 60 40 26	124 118 101 82		dB dB dB dB
Input Voltage Range	IVR		$\pm 8$			V
Input Resistance	$R_{\text{IN}}$	Differential, $G = 1000$ $G = 1$ Common Mode, $G = 1000$ $G = 1$		1 30 5.3 7.1		$\text{M}\Omega$ $\text{M}\Omega$ $\text{M}\Omega$ $\text{M}\Omega$
<b>OUTPUT</b>						
Output Voltage Swing	$V_O$	$R_L = 2\text{ k}\Omega; T_A = +25^\circ\text{C}$	$\pm 11.0$	$\pm 12.3$		V
Output Offset Voltage	$V_{\text{OOS}}$	$T_A = +25^\circ\text{C}$ $T_A = -40^\circ\text{C to } +85^\circ\text{C}$		-40 2 4.7	500	mV k $\Omega$ k $\Omega$
Minimum Resistive Load Drive				50		pF
Maximum Capacitive Load Drive				$\pm 50$		mA
Short Circuit Current Limit	$I_{\text{SC}}$	Output-to-Ground Short			10	sec
Output Short Circuit Duration						
<b>GAIN</b>						
Gain Accuracy	$R_G = \frac{10\text{ k}\Omega}{G-1}$	$T_A = +25^\circ\text{C}$ $R_G = 10\text{ }\Omega, G = 1000$ $R_G = 101\text{ }\Omega, G = 100$ $R_G = 1.1\text{ k}\Omega, G = 10$ $R_G = \infty, G = 1$		0.25 0.20 0.20 0.05 70	1 1 1 0.5	dB dB dB dB dB
Maximum Gain	G					
<b>REFERENCE INPUT</b>						
Input Resistance				10		k $\Omega$
Voltage Range				$\pm 8$		V
Gain to Output				1		V/V
<b>POWER SUPPLY</b>						
Supply Voltage Range	$V_S$		$\pm 6$		$\pm 22$	V
Supply Current	$I_{\text{SY}}$	$V_{\text{CM}} = 0\text{ V}, R_L = \infty$		$\pm 10.6$	$\pm 14.0$	mA

Specifications subject to change without notice.

## Typical Performance Characteristics

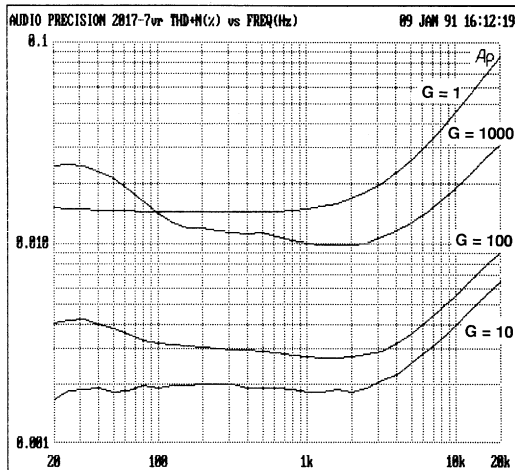

Figure 1. Typical THD+Noise\* at  $G = 1, 10, 100, 1000$ ;  
 $V_O = 7 V_{RMS}$ ,  $V_S = \pm 15 V$ ,  $R_L = 5 k\Omega$ ;  $T_A = +25^\circ C$

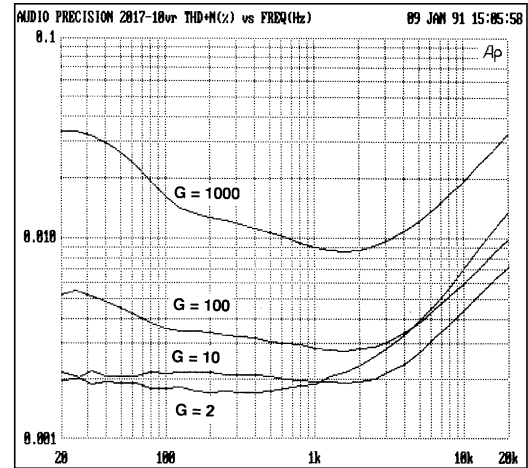

Figure 2. Typical THD+ Noise \* at  $G = 2, 10, 100, 1000$ ;  
 $V_O = 10 V_{RMS}$ ,  $V_S = \pm 18 V$ ,  $R_L = 5 k\Omega$ ;  $T_A = +25^\circ C$

\*80 kHz low-pass filter used for Figures 1-2.

### ABSOLUTE MAXIMUM RATINGS

Supply Voltage	$\pm 22 V$
Input Voltage	Supply Voltage
Output Short Circuit Duration	10 sec
Storage Temperature Range (P, Z Packages)	$-65^\circ C$ to $+150^\circ C$
Junction Temperature ( $T_J$ )	$-65^\circ C$ to $+150^\circ C$
Lead Temperature Range (Soldering, 60 sec)	$300^\circ C$
Operating Temperature Range	$-40^\circ C$ to $+85^\circ C$
Thermal Resistance*	
8-Pin Hermetic DIP (Z): $\theta_{JA} = 134$ ; $\theta_{JC} = 12$	$^\circ C/W$
8-Pin Plastic DIP (P): $\theta_{JA} = 96$ ; $\theta_{JC} = 37$	$^\circ C/W$
16-Pin SOIC (S): $\theta_{JA} = 92$ ; $\theta_{JC} = 27$	$^\circ C/W$

\* $\theta_{JA}$  is specified for worst case mounting conditions, i.e.,  $\theta_{JA}$  is specified for device in socket for cerdip and plastic DIP;  $\theta_{JA}$  is specified for device soldered to printed circuit board for SOL package.

### ORDERING GUIDE

Model	Temperature Range*	Package Description	Package Option
SSM2017P	$-40^\circ C$ to $+85^\circ C$	8-Pin Plastic DIP	N-8
SSM2017S	$-40^\circ C$ to $+85^\circ C$	16-Lead SOL	R-16
SSM2017S-REEL	$-40^\circ C$ to $+85^\circ C$	16-Lead SOL	R-16

\*XIND =  $-40^\circ C$  to  $+85^\circ C$ .

### CAUTION

ESD (electrostatic discharge) sensitive device. Electrostatic charges as high as 4000 V readily accumulate on the human body and test equipment and can discharge without detection. Although the SSM2017 features proprietary ESD protection circuitry, permanent damage may occur on devices subjected to high energy electrostatic discharges. Therefore, proper ESD precautions are recommended to avoid performance degradation or loss of functionality.



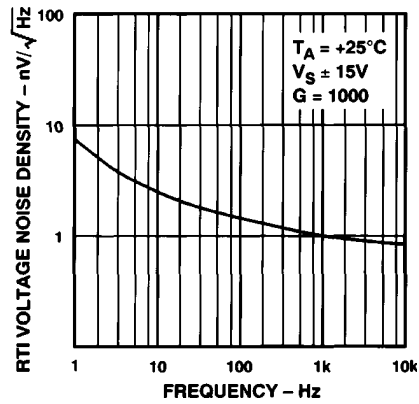

Figure 3. Voltage Noise Density vs. Frequency

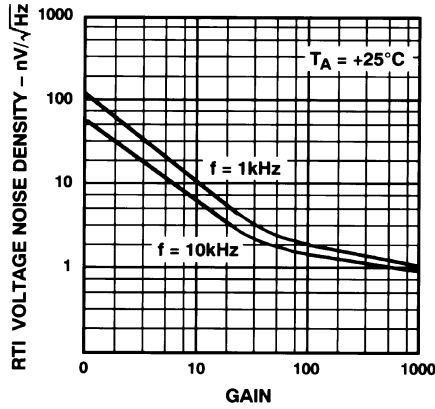

Figure 4. RTI Voltage Noise Density vs. Gain

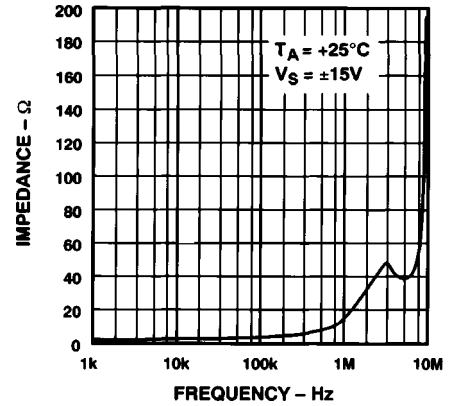

Figure 5. Output Impedance vs. Frequency

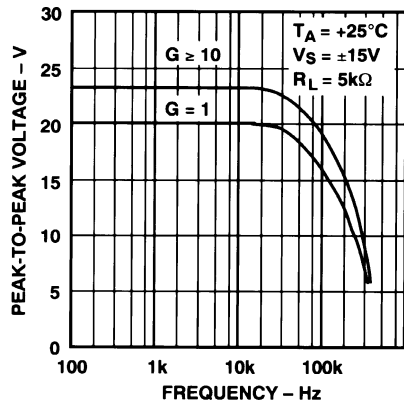

Figure 6. Maximum Output Swing vs. Frequency

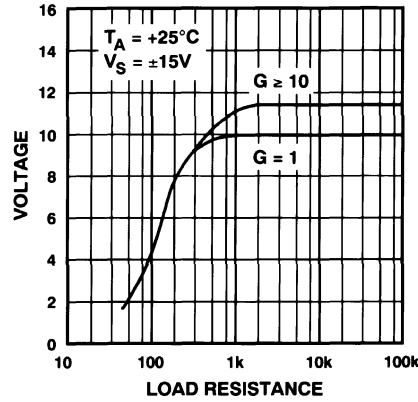

Figure 7. Maximum Output Voltage vs. Load Resistance

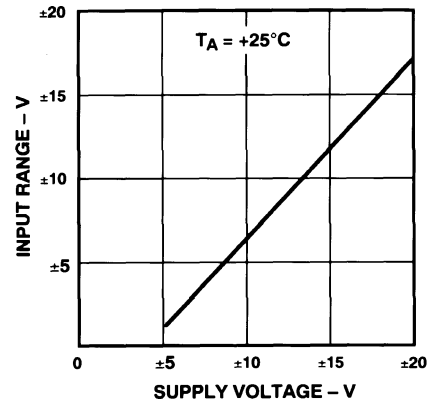

Figure 8. Input Voltage Range vs. Supply Voltage

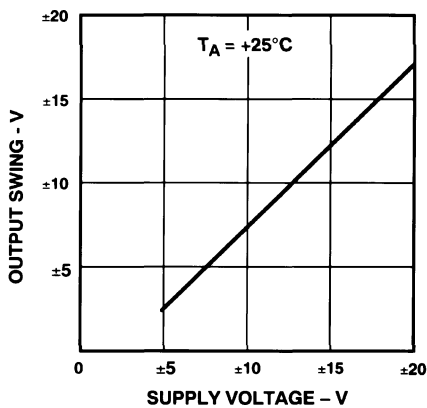

Figure 9. Output Voltage Range vs. Supply Voltage

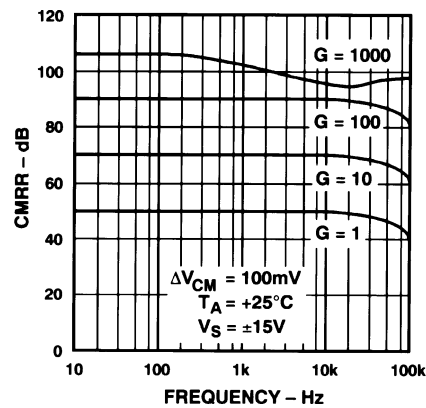

Figure 10. CMRR vs. Frequency

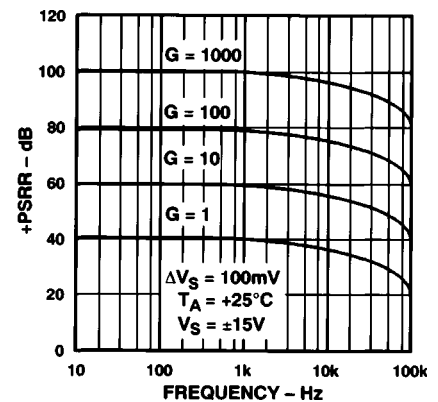

Figure 11. +PSRR vs. Frequency

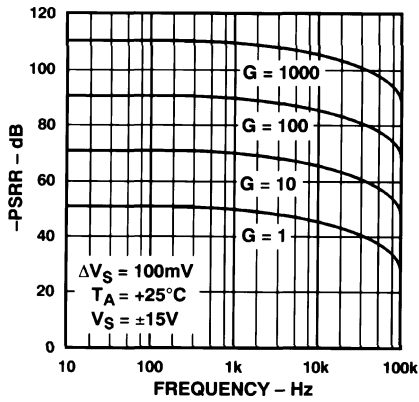

Figure 12. -PSRR vs. Frequency

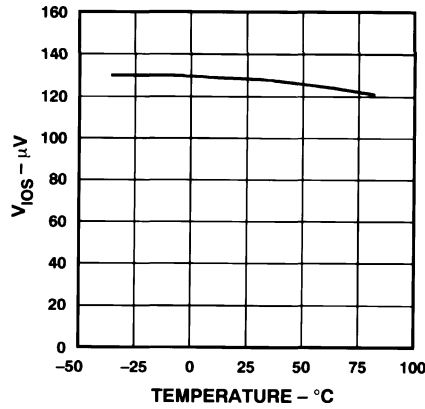

Figure 13.  $V_{IOS}$  vs. Temperature

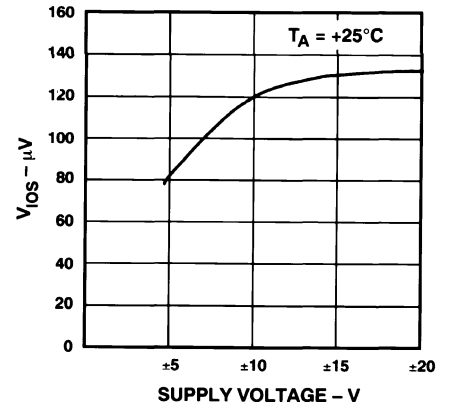

Figure 14.  $V_{IOS}$  vs. Supply Voltage

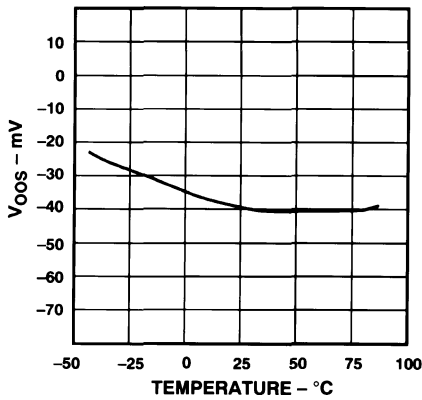

Figure 15.  $V_{OOS}$  vs. Temperature

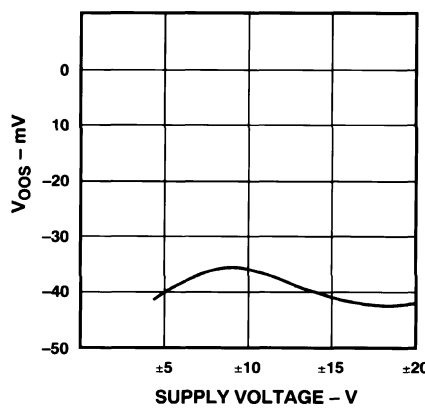

Figure 16.  $V_{OOS}$  vs. Supply Voltage

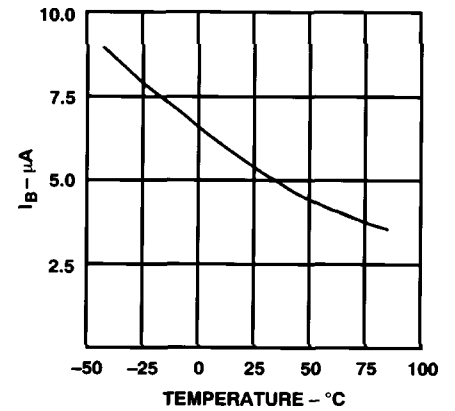

Figure 17.  $I_B$  vs. Temperature

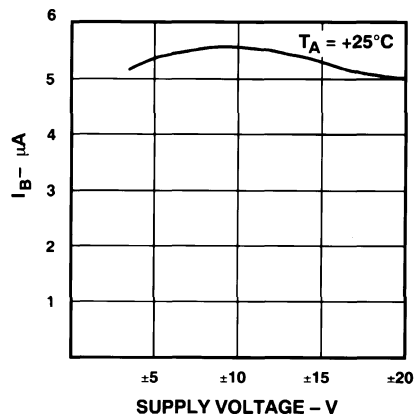

Figure 18.  $I_B$  vs. Supply Voltage

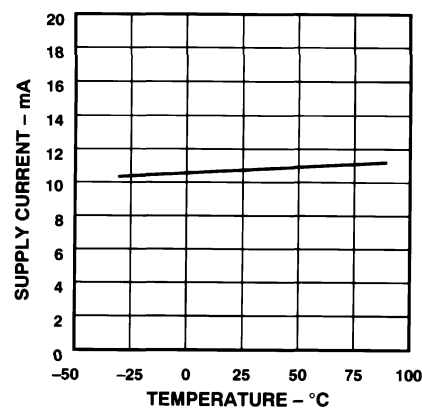

Figure 19.  $I_{SY}$  vs. Temperature

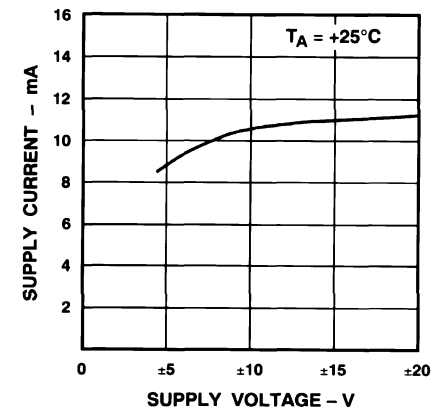
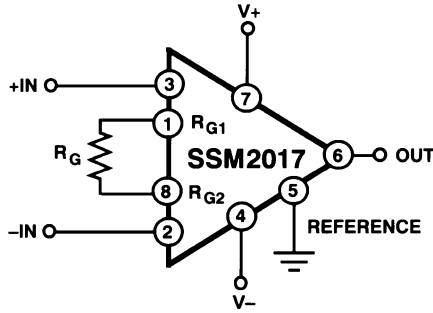

Figure 20.  $I_{SY}$  vs. Supply Voltage

# SSM2017



$$G = \frac{V_{OUT}}{(+In) - (-In)} = \left( \frac{10\text{ k}\Omega}{R_G} \right) + 1$$

Basic Circuit Connections

## GAIN

The SSM2017 only requires a single external resistor to set the voltage gain. The voltage gain,  $G$ , is:

$$G = \frac{10\text{ k}\Omega}{R_G} + 1$$

and

$$R_G = \frac{10\text{ k}\Omega}{G - 1}$$

For convenience, Table I lists various values of  $R_G$  for common gain levels.

**Table I. Values of  $R_G$  for Various Gain Levels**

$A_V$	dB	$R_G$
1	0	NC
3.2	10	4.7k
10	20	1.1k
31.3	30	330
100	40	100
314	50	32
1000	60	10

The voltage gain can range from 1 to 3500. A gain set resistor is not required for unity gain applications. Metal-film or wire-wound resistors are recommended for best results.

The total gain accuracy of the SSM2017 is determined by the tolerance of the external gain set resistor,  $R_G$ , combined with the gain equation accuracy of the SSM2017. Total gain drift combines the mismatch of the external gain set resistor drift with that of the internal resistors (20 ppm/°C typ).

Bandwidth of the SSM2017 is relatively independent of gain as shown in Figure 21. For a voltage gain of 1000, the SSM2017 has a small-signal bandwidth of 200 kHz. At unity gain, the bandwidth of the SSM2017 exceeds 4 MHz.

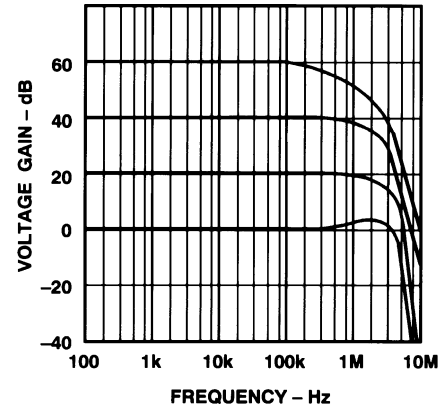

Figure 21. Bandwidth of the SSM2017 for Various Values of Gain

## NOISE PERFORMANCE

The SSM2017 is a very low noise audio preamplifier exhibiting a typical voltage noise density of only 1 nV/√Hz at 1 kHz. The exceptionally low noise characteristics of the SSM2017 are in part achieved by operating the input transistors at high collector currents since the voltage noise is inversely proportional to the square root of the collector current. Current noise, however, is directly proportional to the square root of the collector current. As a result, the outstanding voltage noise performance of the SSM2017 is obtained at the expense of current noise performance. At low preamplifier gains, the effect of the SSM2017's voltage and current noise is insignificant.

The total noise of an audio preamplifier channel can be calculated by:

$$E_n = \sqrt{e_n^2 + (i_n R_S)^2 + e_t^2}$$

where:

$E_n$  = total input referred noise

$e_n$  = amplifier voltage noise

$i_n$  = amplifier current noise

$R_S$  = source resistance

$e_t$  = source resistance thermal noise.

For a microphone preamplifier, using a typical microphone impedance of 150 Ω the total input referred noise is:

$e_n = 1\text{ nV}/\sqrt{\text{Hz}} @ 1\text{ kHz}$ , SSM2017  $e_n$

$i_n = 2\text{ pA}/\sqrt{\text{Hz}} @ 1\text{ kHz}$ , SSM2017  $i_n$

$R_S = 150\ \Omega$ , microphone source impedance

$e_t = 1.6\text{ nV}/\sqrt{\text{Hz}} @ 1\text{ kHz}$ , microphone thermal noise

$$E_n = \sqrt{(1\text{ nV}/\sqrt{\text{Hz}})^2 + 2(pA/\sqrt{\text{Hz}} \times 150\ \Omega)^2 + (1.6\text{ nV}/\sqrt{\text{Hz}})^2} \\ = 1.93\text{ nV}/\sqrt{\text{Hz}} @ 1\text{ kHz}.$$

This total noise is extremely low and makes the SSM2017 virtually transparent to the user.

**INPUTS**

The SSM2017 has protection diodes across the base emitter junctions of the input transistors. These prevent accidental avalanche breakdown which could seriously degrade noise performance. Additional clamp diodes are also provided to prevent the inputs from being forced too far beyond the supplies.

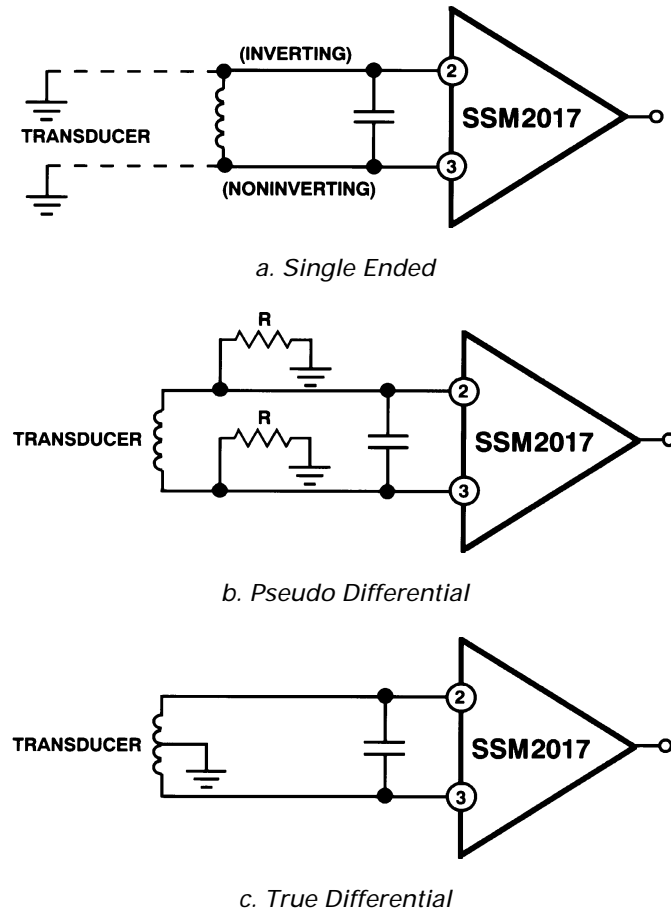

Figure 22. Three Ways of Interfacing Transducers for High Noise Immunity

Although the SSM2017's inputs are fully floating, care must be exercised to ensure that both inputs have a dc bias connection capable of maintaining them within the input common-mode range. The usual method of achieving this is to ground one side of the transducer as in Figure 22a, but an alternative way is to float the transducer and use two resistors to set the bias point as in Figure 22b. The value of these resistors can be up to 10 k $\Omega$ , but they should be kept as small as possible to limit common-mode pickup. Noise contribution by resistors themselves is negligible since it is attenuated by the transducer's impedance. Balanced transducers give the best noise immunity and interface directly as in Figure 22c.

**REFERENCE TERMINAL**

The output signal is specified with respect to the reference terminal, which is normally connected to analog ground. The reference may also be used for offset correction or level shifting. A reference source resistance will reduce the common-mode rejection by the ratio of 5 k $\Omega$ / $R_{REF}$ . If the reference source resistance is 1  $\Omega$ , then the CMR will be reduced to 74 dB (5 k $\Omega$ /1  $\Omega$  = 74 dB).

**COMMON-MODE REJECTION**

Ideally, a microphone preamplifier responds only to the difference between the two input signals and rejects common-mode voltages and noise. In practice, there is a small change in output voltage when both inputs experience the same common-mode voltage change; the ratio of these voltages is called the common-mode gain. Common-mode rejection (CMR) is the logarithm of the ratio of differential-mode gain to common-mode gain, expressed in dB.

**PHANTOM POWERING**

A typical phantom microphone powering circuit is shown in Figure 23.  $Z_1$  through  $Z_4$  provide transient overvoltage protection for the SSM2017 whenever microphones are plugged in or unplugged.

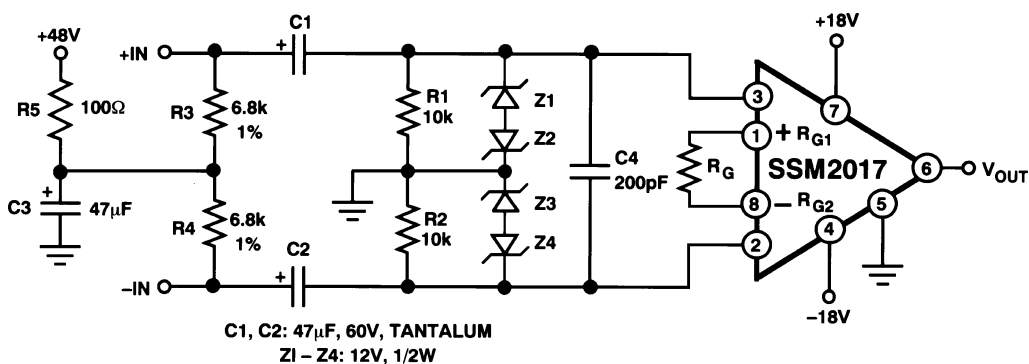

Figure 23. SSM2017 in Phantom Powered Microphone Circuit

# SSM2017

## BUS SUMMING AMPLIFIER

In addition to its use as a microphone preamplifier, the SSM2017 can be used as a very low noise summing amplifier. Such a circuit is particularly useful when many medium impedance outputs are summed together to produce a high effective noise gain.

The principle of the summing amplifier is to ground the SSM2017 inputs. Under these conditions, Pins 1 and 8 are ac virtual grounds sitting about 0.55 V below ground.

To remove the 0.55 V offset, the circuit of Figure 24 is recommended.

A<sub>2</sub> forms a "servo" amplifier feeding the SSM2017's inputs. This places Pins 1 and 8 at a true dc virtual ground. R<sub>4</sub> in conjunction with C<sub>2</sub> remove the voltage noise of A<sub>2</sub>, and in fact just about any operational amplifier will work well here since it is removed from the signal path. If the dc offset at Pins 1 and 8 is not too critical, then the servo loop can be replaced by the diode biasing scheme of Figure 24. If ac coupling is used throughout, then Pins 2 and 3 may be directly grounded.

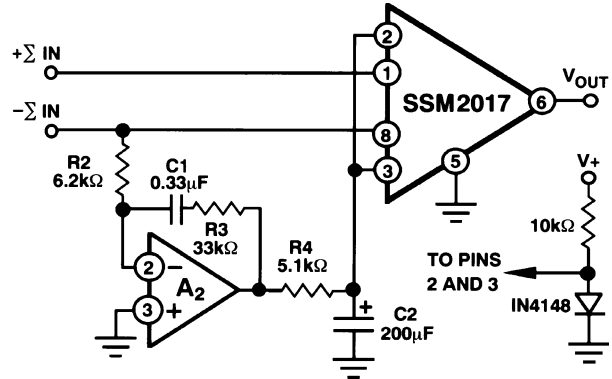
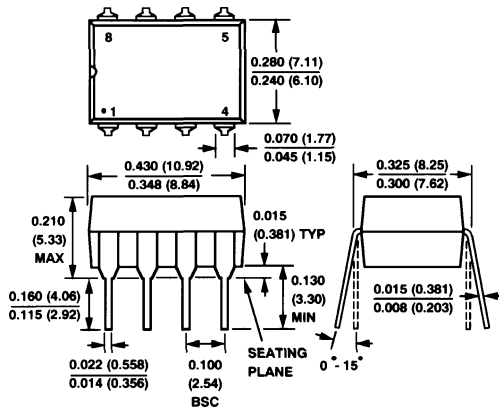

Figure 24. Bus Summing Amplifier

## OUTLINE DIMENSIONS

Dimensions shown in inches and (mm).

### 8-Pin Plastic DIP (P) Package



### 8-Pin Hermetic DIP (Z) Package

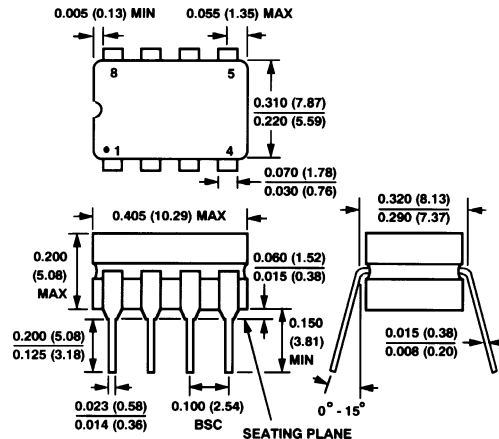

### 16-Pin SOIC (S) Package

