



Obsolescence Notice

This product is obsolete.

This information is available for your convenience only.

For more information on Zarlink's obsolete products and replacement product lists, please visit http://products.zarlink.com/obsolete_products/

The SP5510 is a single-chip frequency synthesiser designed for TV tuning systems. Control data is entered in the standard I²C BUS format. The device has four addressable current-limited output ports (P0-P3) and four bi-directional open-collector ports (P4-P7), one of which (P6) is also a 3-bit 5-level ADC input. The information on these ports can be read via the I²C BUS. The SP5510S is a variant in a 16-lead miniature plastic package, without P0-P2 but functionally identical in other respects.

Both variants have one fixed I²C BUS address and three programmable addresses, allowing two or more synthesisers to be used in a system.

FEATURES

- Complete 1.3GHz Single Chip System
- Programmable via the I²C BUS
- Low Power Consumption (215mW Typ.)
- Low Radiation
- Phase Lock Detector
- Varactor Drive Amp Disable
- 8 Controllable Outputs, 4 Bi-directional (SP5510)
- 5 Controllable Outputs, 4 Bi-directional (SP5510S)
- 5-Level ADC
- Variable I²C BUS Address for Picture in Picture TV
- ESD Protection *

* Normal ESD handling precautions should be observed.

APPLICATIONS

- Cable Tuning Systems
- VCRs

DS2184

ISSUE 4.2

November 2001

Ordering Information

- SP5510G/KG/DPAS (Tubes)
(18 lead Dual-in-line plastic package)
- SP5510GS/KG/MPAS (Tubes)
SP5510GS/KG/MPAD (Tape & Reel)
(16 lead miniature plastic package)

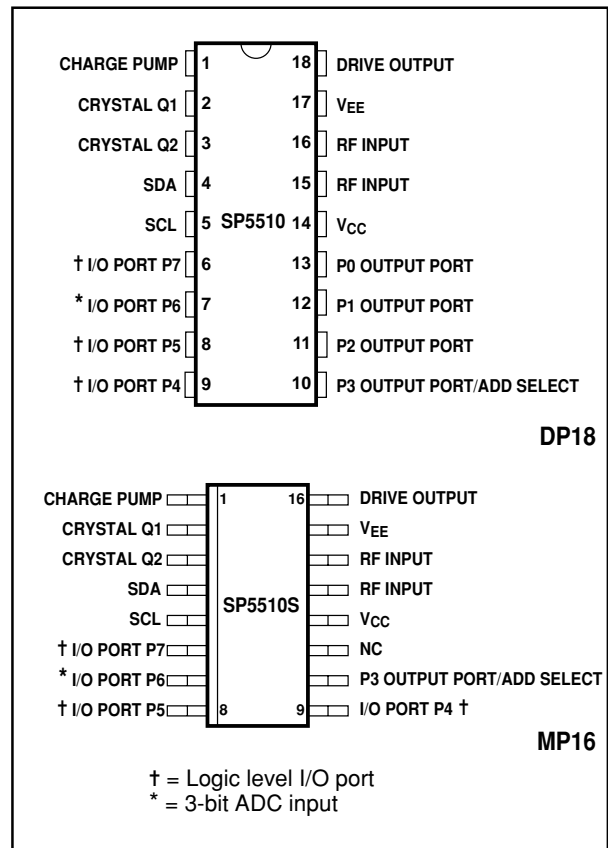

Fig. 1 Pin connections – top view

SP5510

ELECTRICAL CHARACTERISTICS

$T_{AMB} = -10^{\circ}\text{C}$ to $+80^{\circ}\text{C}$, $V_{CC} = +4.5\text{V}$ to $+5.5\text{V}$. All pin references are to the SP5510 (DP18 package). These Characteristics are guaranteed by either production test or design. They apply within the specified ambient temperature and supply voltage ranges unless otherwise stated. Reference frequency 4MHz unless otherwise stated.

Characteristic	Pin	Value			Units	Conditions
		Min.	Typ.	Max.		
Supply current	14		43	53	mA	$V_{CC} = 5\text{V}$ 50MHz to 1GHz 1.3GHz, see Fig. 5
Prescaler input voltage	15,16	12.5		300	mVrms	
Prescaler input voltage		30		300	mVrms	
Prescaler input impedance	15,16		50		Ω	
Prescaler input capacitance			2		pF	
SDA, SCL						
Input high voltage	4,5	3		5.5	V	Input voltage = V_{CC} Input voltage = 0V When $V_{CC} = 0\text{V}$
Input low voltage	4,5	0		1.5	V	
Input high current	4,5			10	μA	
Input low current	4,5			-10	μA	
Leakage current	4,5			10	μA	
SDA						
Output voltage	4			0.4	V	Sink current = 3mA
Charge pump current low	1		± 50		μA	Byte 4, bit 2 = 0, pin 1 = 2V Byte 4, bit 2 = 1, pin 1 = 2V Byte 4, bit 4 = 1, pin 1 = 2V V pin 18 = 0.7V
Charge pump current high	1		± 170		μA	
Charge pump output leakage current	1			± 5	nA	
Charge pump drive output current	18	500				Parallel resonant crystal (note 2)
Charge pump amplifier gain			± 400			
Recommended crystal series resistance		10		200	Ω	
Crystal oscillator drive level			40		mV p-p	
Crystal oscillator negative resistance	2	750			Ω	
Output Ports						
P0-P3 sink current (see note 1)	10-13	0.7	1	1.5	mA	$V_{OUT} = 12\text{V}$ $V_{OUT} = 13.2\text{V}$
P0-P3 leakage current (see note 1)	10-13			10	μA	
P4-P7 sink current	6-9	10			mA	$V_{OUT} = 0.7\text{V}$ $V_{OUT} = 13.2\text{V}$
P4-P7 leakage current	6-9			10	μA	
Input Ports						
P3 input current high	10			+10	μA	V pin 10 = 13.2V V pin 10 = 0V
P3 input current low	10			-10	μA	
P4, P5, P7 input voltage low	6,8,9			0.8	V	See Table 3 for ADC levels
P4, P5, P7 input voltage high	6,8,9	2.7			V	
P6 input current high	7			+10	μA	
P6 input current low	7			-10	μA	

NOTES

- Ports P0-P2 not present on the SP5510S.
- The maximum resistance quoted refers to all conditions, including start-up.

ABSOLUTE MAXIMUM RATINGS

All voltages are referred to V_{EE} and pin 3 at 0V. Pin references are for SP5510 (DP18 package)

Parameter	Pin	Value		Units	Conditions
		Min.	Max.		
Supply voltage	14	-0.3	7	V	
RF input voltage	15,16		2.5	V p-p	
Port voltage	6-13	-0.3	14	V	Port in off state
	6-9	-0.3	6	V	Port in on state
	10-13	-0.3	14	V	Port in on state
Total port output current	6-13		50	mA	
RF input DC offset	15-16	-0.3	$V_{CC}+0.3$	V	
Charge pump DC offset	1	-0.3	$V_{CC}+0.3$	V	
Drive output DC offset	18	-0.3	$V_{CC}+0.3$	V	
Crystal oscillator DC offset	2	-0.3	$V_{CC}+0.3$	V	
SDA, SCL input voltage	4,5	-0.3	$V_{CC}+0.3$	V	With V_{CC} applied
		-0.3	5.5	V	V_{CC} not applied
Storage temperature		-55	+150	°C	
Junction temperature			+150	°C	
DP18 thermal resistance, chip-to-ambient			78	°C/W	
DP18 thermal resistance, chip-to-case			24	°C/W	
MP16 thermal resistance, chip-to-ambient			111	°C/W	
MP16 thermal resistance, chip-to-case			41	°C/W	
Power consumption at 5.5V			321	mW	

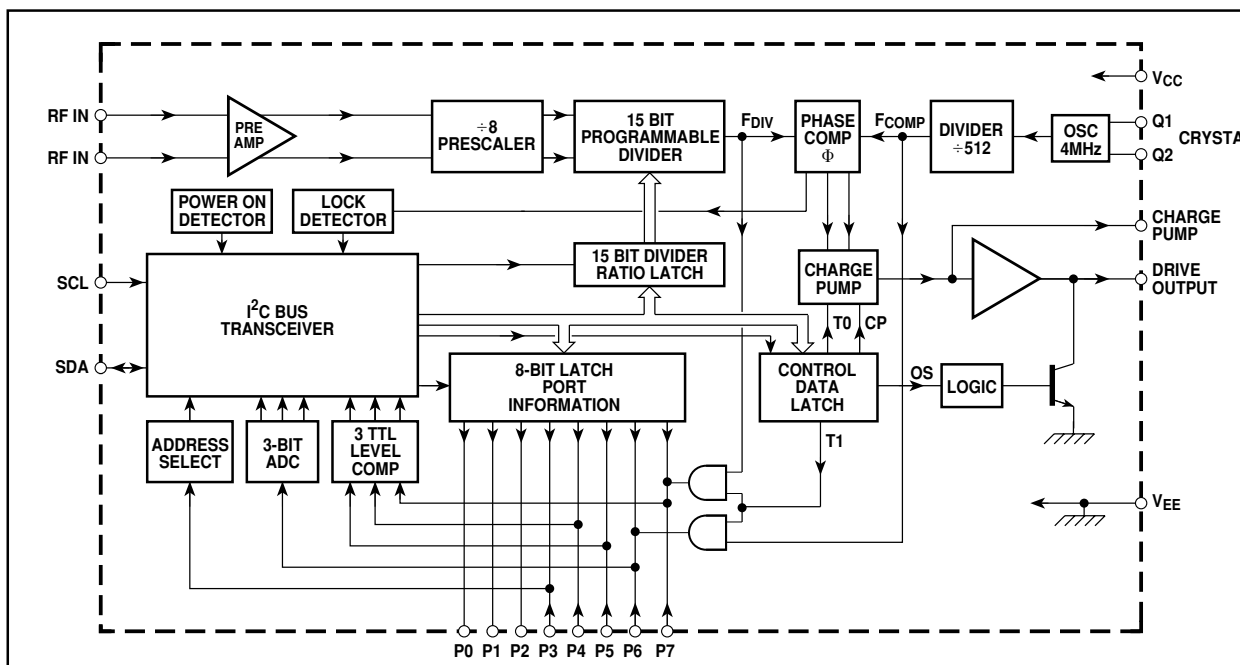

Fig. 2 Block diagram. (Ports P0-P2 not present on SP5510S)

FUNCTIONAL DESCRIPTION

The SP5510 is programmed from an I²C BUS. Data and Clock are fed in on the SDA and SCL lines respectively as defined by the I²C Bus format. The synthesiser can either accept new data (write mode) or send data (read mode). The Tables in Fig. 3 illustrate the format of the data. The device can be programmed to respond to several addresses, which enables the use of more than one synthesiser in an I²C BUS system. Table 4 shows how the address is selected by applying a voltage to P3. The LSB of the address Byte (R/W) sets the device into read mode if it is high and write mode if it is low. When the SP5510 receives a correct address Byte it pulls the SDA line low during the acknowledge period and during following acknowledge periods after further data Bytes are programmed. When the SP5510 is programmed into the read mode the controlling device accepting the data must pull down the SDA line during the following acknowledge period to read another status Byte.

WRITE MODE (FREQUENCY SYNTHESIS)

When the device is in the write mode Bytes 2+3 select the synthesised frequency while Bytes 4+5 select the output port states and charge pump information.

Once the correct address is received and acknowledged, the first Bit of the next Byte determines whether that Byte is interpreted as Byte 2 or 4, a logic 0 for frequency information and a logic 1 for charge pump and output port information. Additional data Bytes can be entered without the need to re-address the device until an I²C stop condition is recognised. This allows a smooth frequency sweep for fine tuning or AFC purposes.

If the transmission of data is stopped mid-byte (i.e., by another device on the bus) then the previously programmed byte is maintained.

Frequency data from Bytes 2 and 3 is stored in a 15-bit shift register and is used to control the division ratio of the 15-bit programmable divider which is preceded by a divide-by-8 prescaler and amplifier to give excellent sensitivity at the local oscillator input; see Fig 5. The input impedance is shown in Figs. 7 and 8.

The programmed frequency can be calculated by multiplying the programmed division ratio by 8 times the comparison frequency F_{COMP} .

When frequency data is entered, the phase comparator, via the charge pump and varactor drive amplifier, adjusts the

local oscillator control voltage until the output of the programmable divider is frequency and phase locked to the comparison frequency.

The reference frequency may be generated by an external source capacitively coupled into pin 2 or provided by an on-chip 4MHz crystal controlled oscillator.

Note that the comparison frequency is 7·8125kHz when a 4MHz reference is used.

Bit 2 of Byte 4 of the programming data (CP) controls the current in the charge pump circuit, a logic 1 for $\pm 170\mu A$ and a logic 0 for $\pm 50\mu A$, allowing compensation for the variable tuning slope of the tuner and also to enable fast channel changes over the full band. Bit 4 of Byte 4 (T0) disables the charge pump if set to a logic 1. Bit 8 of Byte 4 (OS) switches the charge pump drive amplifier's output off when it is set to a logic 1. Bit 3 of Byte 4 (T1) selects a test mode where the phase comparator inputs are available on P6 and P7, a logic 1 connects F_{COMP} to P6 and F_{DIV} to P7.

Byte 5 programs the output ports P0-P7, a logic 0 for a high impedance output, logic 1 for low impedance (on).

READ MODE

When the device is in the read mode the status data read from the device on the SDA line takes the form shown in Table 2.

Bit 1 (POR) is the power on reset indicator and is set to a logic 1 if the power supply to the device has dropped below a nominal 3V and the programmed information lost (e.g., when the device is initially turned on). The POR is set to 0 when the read sequence is terminated by a stop command. The outputs are all set to high impedance when the device is initially powered up. Bit 2 (FL) indicates whether the device is phase locked, a logic 1 is present if the device is locked and a logic 0 if the device is unlocked.

Bits 3, 4 and 5 (I2, I1, I0) show the status of the I/O Ports P7, P5 and P4 respectively. A logic 0 indicates a low level and a logic 1 a high level. If the ports are to be used as inputs they should be programmed to a high impedance state (logic 1). These inputs will then respond to data complying with standard TTL voltage levels. Bits 6, 7 and 8 (A2, A1, A0) combine to give the output of the 5-level ADC.

The 5-level ADC can be used to feed AFC information to the microprocessor from the IF section of the television, as illustrated in Fig. 4.

	MSB					LSB				
Address	1	1	0	0	0	MA1	MA0	0	A	Byte 1
Programmable divider	0	2 ¹⁴	2 ¹³	2 ¹²	2 ¹¹	2 ¹⁰	2 ⁹	2 ⁸	A	Byte 2
Programmable divider	2 ⁷	2 ⁶	2 ⁵	2 ⁴	2 ³	2 ²	2 ¹	2 ⁰	A	Byte 3
Charge pump and test bits	1	CP	T1	T0	1	1	1	OS	A	Byte 4
I/O port control bits	P7	P6	P5	P4	P3	P2*	P1*	P0*	A	Byte 5

Table 1 Write data format (MSB transmitted first)

Address	1	1	0	0	0	MA1	MA0	1	A	Byte 1
Status byte	POR	FL	I2	I1	I0	A2	A1	A0	A	Byte 2

Table 2 Read data format

A2	A1	A0	Voltage input to P6
1	0	0	0.6V _{CC} to 13.2V
0	1	1	0.45V _{CC} to 0.6V _{CC}
0	1	0	0.3V _{CC} to 0.45V _{CC}
0	0	1	0.15V _{CC} to 0.3V _{CC}
0	0	0	0V to 0.15V _{CC}

Table 3 ADC levels

MA1	MA0	Voltage input to P3
0	0	0V to 0.2V _{CC}
0	1	Always valid
1	0	0.3V _{CC} to 0.7V _{CC}
1	1	0.8V _{CC} to 13.2V

Table 4 Address selection

- A** : Acknowledge bit
- MA1, MA0** : Variable address bits (see Table 4)
- CP** : Charge Pump current select
- T1** : Test mode selection
- T0** : Charge pump disable
- OS** : Varactor drive Output disable Switch
- P7, P6, P5, P4, P3, P2*, P1*, P0*** : Control output port states
- POR** : Power On Reset indicator
- FL** : Phase lock detect flag
- I2, I1, I0** : Digital information from ports P7, P5 and P4 respectively
- A2, A1, A0** : 5-level ADC data from P6 (see Table 3)

NOTE

* Don't care condition on SP5510S.

Fig. 3 Data formats

SP5510

APPLICATION

A typical application is shown in Fig. 4. All input/output interface circuits are shown in Fig. 6.

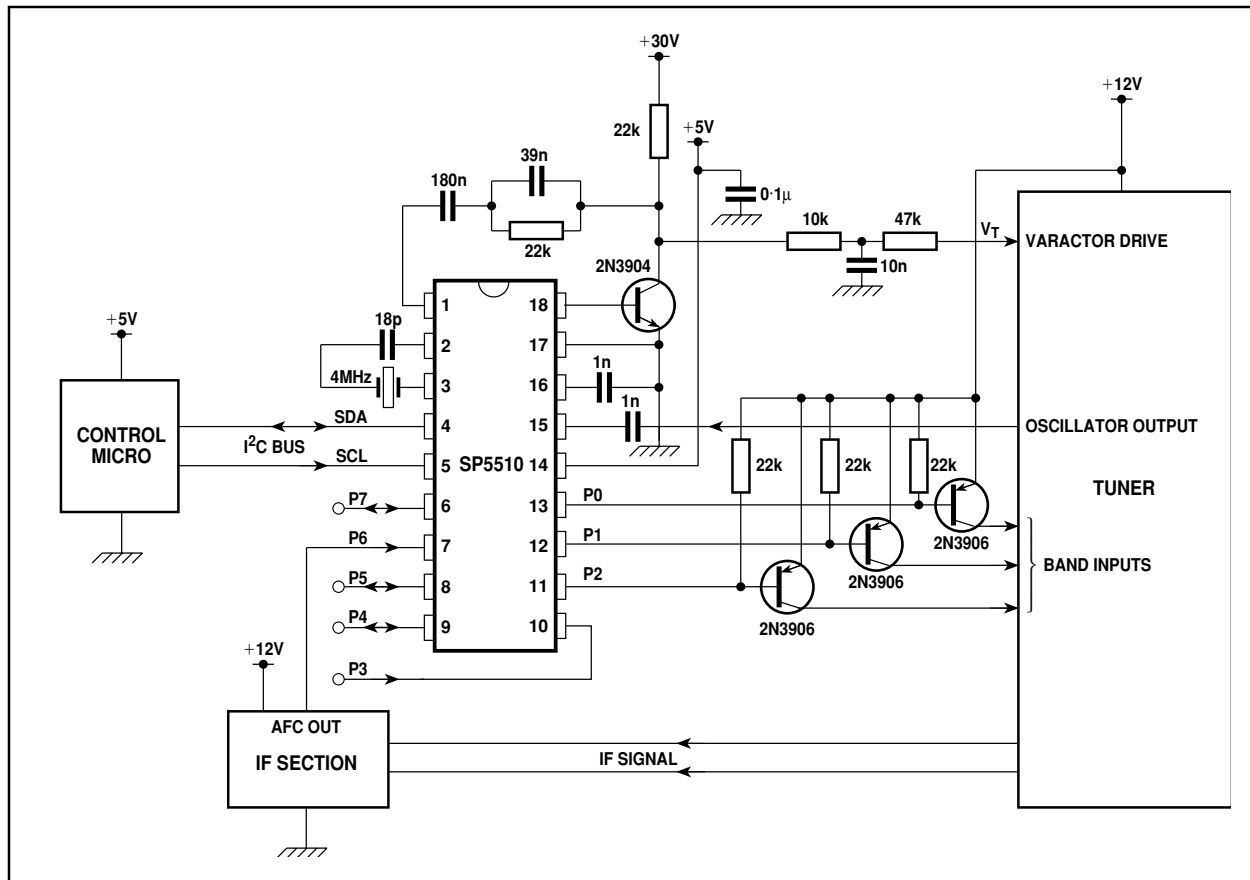

Fig. 4 Typical application

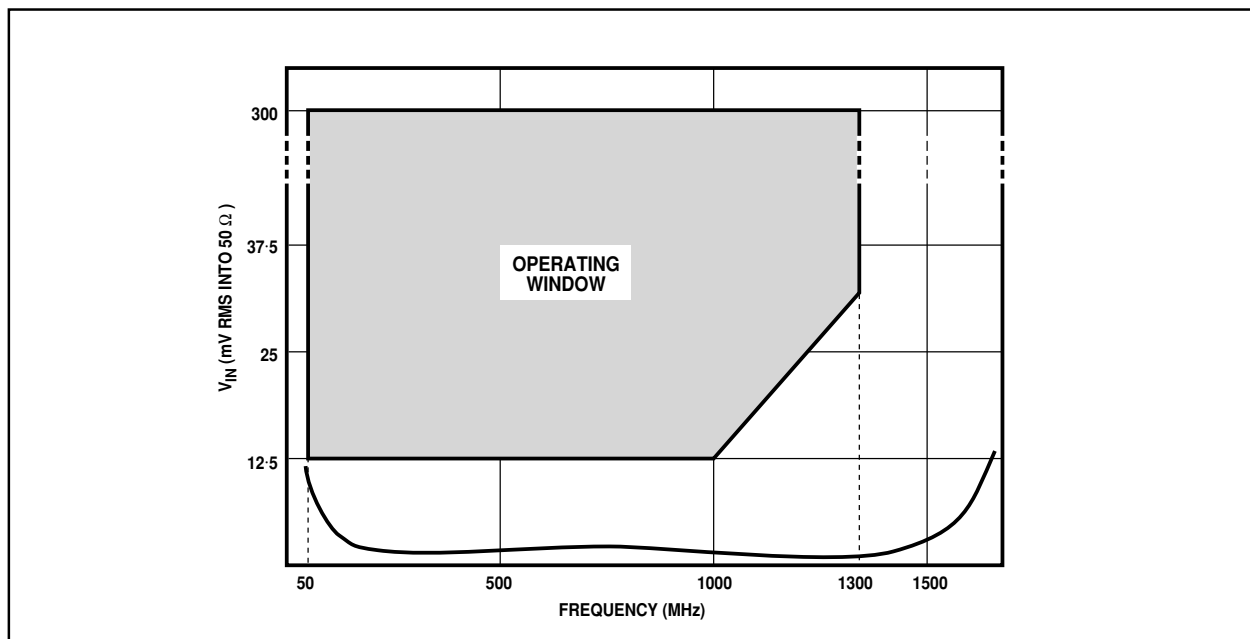

Fig. 5 Typical input sensitivity

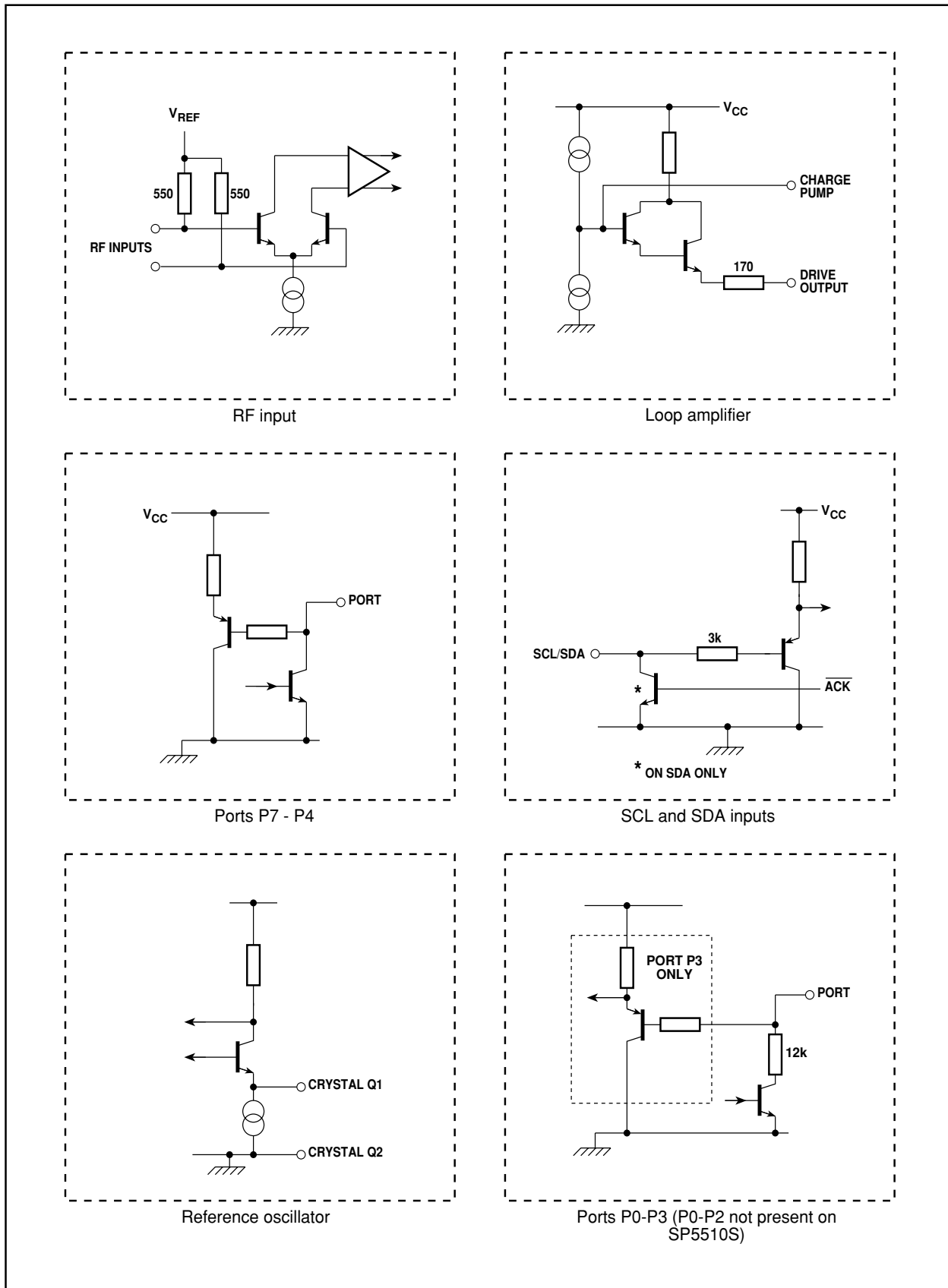

Fig. 6 SP5510 input/output interface circuits

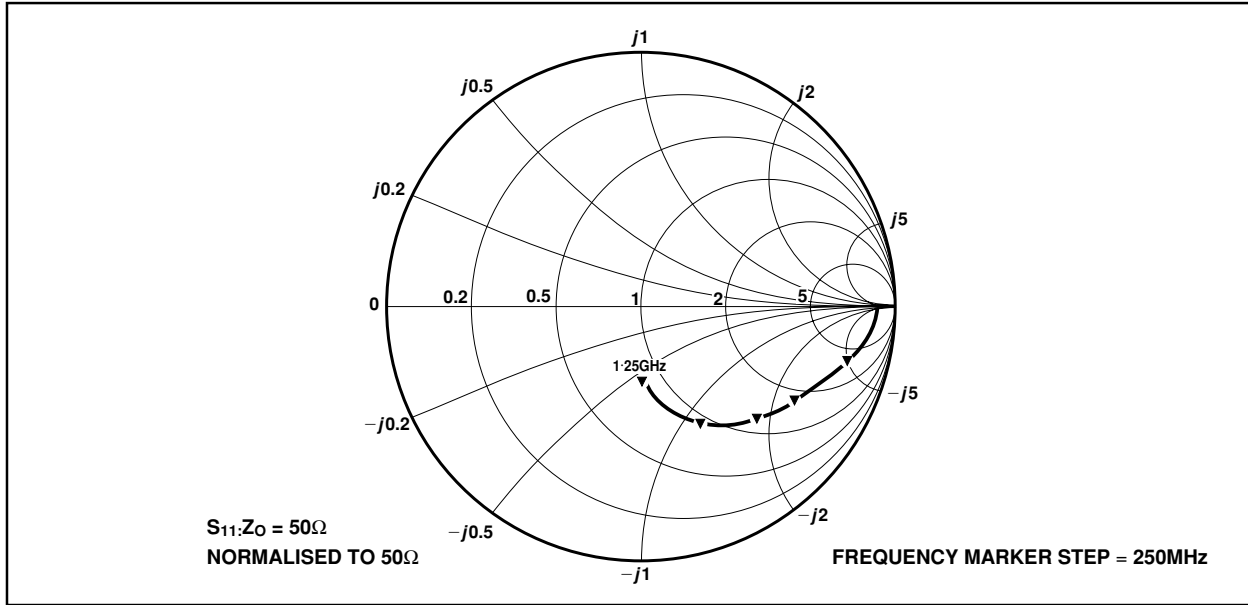

Fig. 7 Typical input impedance, SP5510

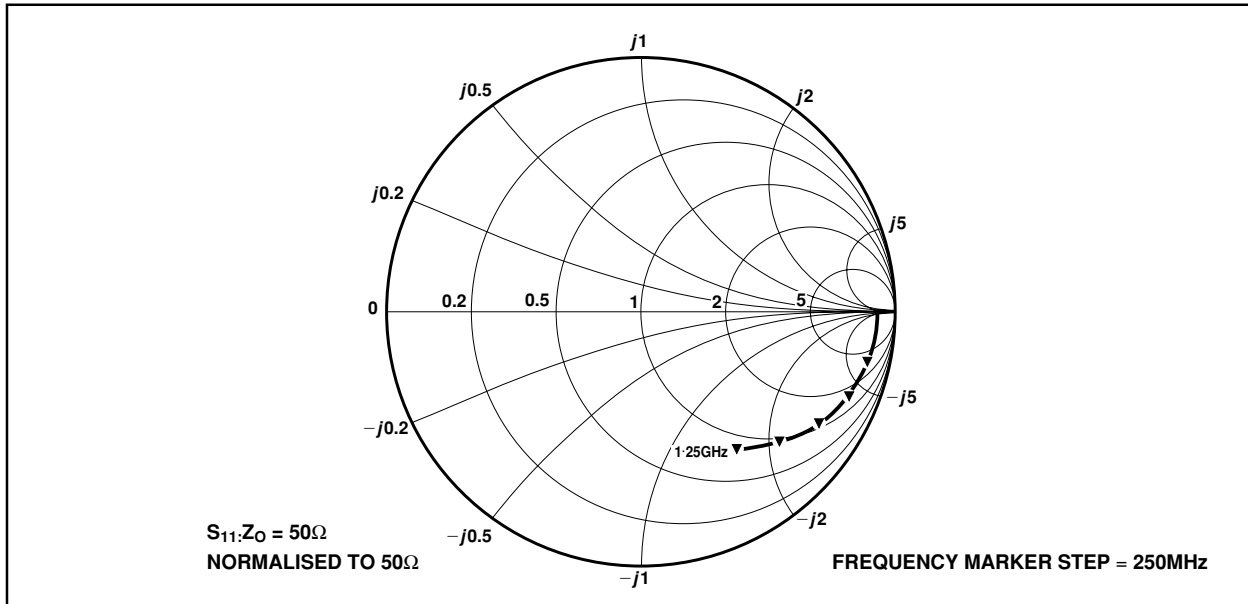
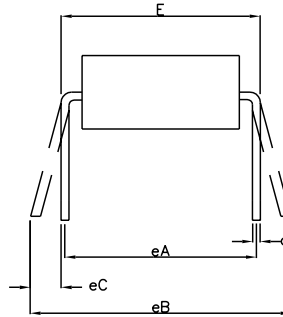
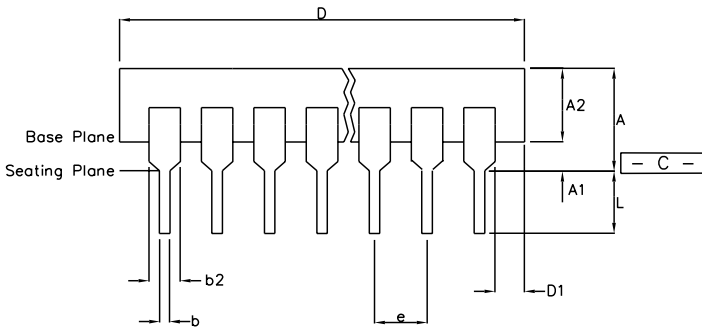
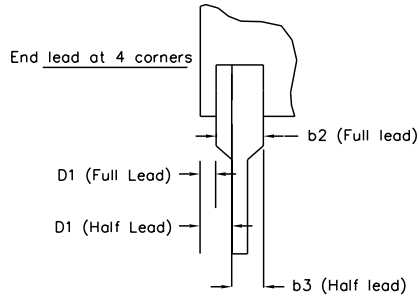
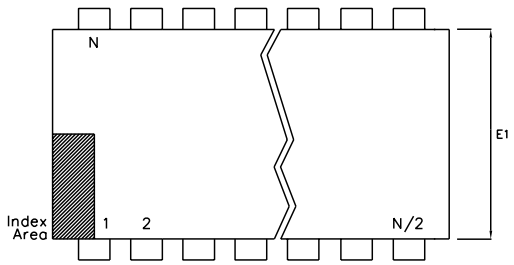

Fig. 8 Typical input impedance, SP5510S



	Min mm	Max mm	Min Inches	Max Inches
A		5.33		0.210
A1	0.38		0.015	
A2	2.92	4.95	0.115	0.195
b	0.36	0.56	0.014	0.022
b2	1.14	1.78	0.045	0.070
b3	n/a	n/a	n/a	n/a
c	0.20	0.36	0.008	0.014
D	22.35	23.37	0.880	0.920
D1	0.13		0.005	
E	7.62	8.26	0.300	0.325
E1	6.10	7.11	0.240	0.280
e	2.54	BSC	0.100	BSC
eA	7.62	BSC	0.300	BSC
eB		10.92		0.430
eC	0.00	1.52	0.000	0.060
L	2.92	3.81	0.115	0.150
N		18		18

Conforms to Jeduc MS-001AC Issue D

Notes:

1. Leadframe Material: Copper
2. Leadframe finish: Solder Plate
3. Dimensions D, D1 & E1 do not include mould flash or protrusions.
4. Dimensions E & eA are measured with leads constrained to be perpendicular to datum --- C ---
5. Dimensions eB & eC are measured with the leads unconstrained
6. Controlling dimensions are Inches. Millimeter conversions are not necessarily exact.
7. N is the maximum of terminal positions.

This drawing supersedes: -
Plymouth/Swindon drawing # 418/ED/39502/004

© Zarlink Semiconductor 2002 All rights reserved.			
ISSUE	1	2	
ACN	202563	212483	
DATE	9Jun97	5Apr02	
APPRD.			



Previous package codes	DP / E
------------------------	--------

Package Code	DA
Package Outline for 18 Lead PDIP	
GPD00348	



**For more information about all Zarlink products
visit our Web Site at
www.zarlink.com**

Information relating to products and services furnished herein by Zarlink Semiconductor Inc. or its subsidiaries (collectively "Zarlink") is believed to be reliable. However, Zarlink assumes no liability for errors that may appear in this publication, or for liability otherwise arising from the application or use of any such information, product or service or for any infringement of patents or other intellectual property rights owned by third parties which may result from such application or use. Neither the supply of such information or purchase of product or service conveys any license, either express or implied, under patents or other intellectual property rights owned by Zarlink or licensed from third parties by Zarlink, whatsoever. Purchasers of products are also hereby notified that the use of product in certain ways or in combination with Zarlink, or non-Zarlink furnished goods or services may infringe patents or other intellectual property rights owned by Zarlink.

This publication is issued to provide information only and (unless agreed by Zarlink in writing) may not be used, applied or reproduced for any purpose nor form part of any order or contract nor to be regarded as a representation relating to the products or services concerned. The products, their specifications, services and other information appearing in this publication are subject to change by Zarlink without notice. No warranty or guarantee express or implied is made regarding the capability, performance or suitability of any product or service. Information concerning possible methods of use is provided as a guide only and does not constitute any guarantee that such methods of use will be satisfactory in a specific piece of equipment. It is the user's responsibility to fully determine the performance and suitability of any equipment using such information and to ensure that any publication or data used is up to date and has not been superseded. Manufacturing does not necessarily include testing of all functions or parameters. These products are not suitable for use in any medical products whose failure to perform may result in significant injury or death to the user. All products and materials are sold and services provided subject to Zarlink's conditions of sale which are available on request.

Purchase of Zarlink's I²C components conveys a licence under the Philips I²C Patent rights to use these components in and I²C System, provided that the system conforms to the I²C Standard Specification as defined by Philips.

Zarlink, ZL and the Zarlink Semiconductor logo are trademarks of Zarlink Semiconductor Inc.

Copyright Zarlink Semiconductor Inc. All Rights Reserved.

TECHNICAL DOCUMENTATION - NOT FOR RESALE