

# TA8192F

## POWER DRIVER IC FOR CD PLAYER

TA8192F is a power driver IC developed for CD players. It controls the focus/tracking coil of a 3-beam pickup head, the disc motor and feed motor.

### FEATURES

- BTL power drivers for 2 channels.
- Circuits can reduce external components without utilizing a bootstrap technique.
- High output voltage.
- High output current :  $I_O$  (Typ.) = 0.5A
- Wide operating power supply voltage range :  $V_{CC} = 4 \sim 12V$
- Gain switch / output off (VR fixed output) are possible.  
Gain selection : 2, 4, 6 times
- Built-in thermal shutdown circuit.
- 20 pin power flat package.

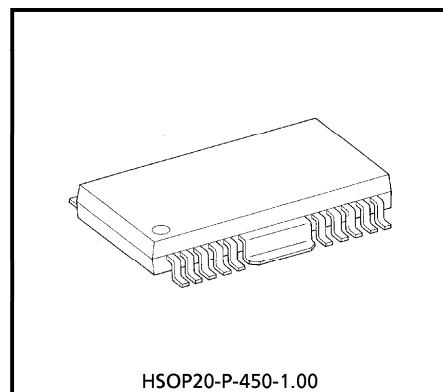

HSOP20-P-450-1.00

Weight : 0.8g (Typ.)

### BLOCK DIAGRAM / PIN CONNECTION

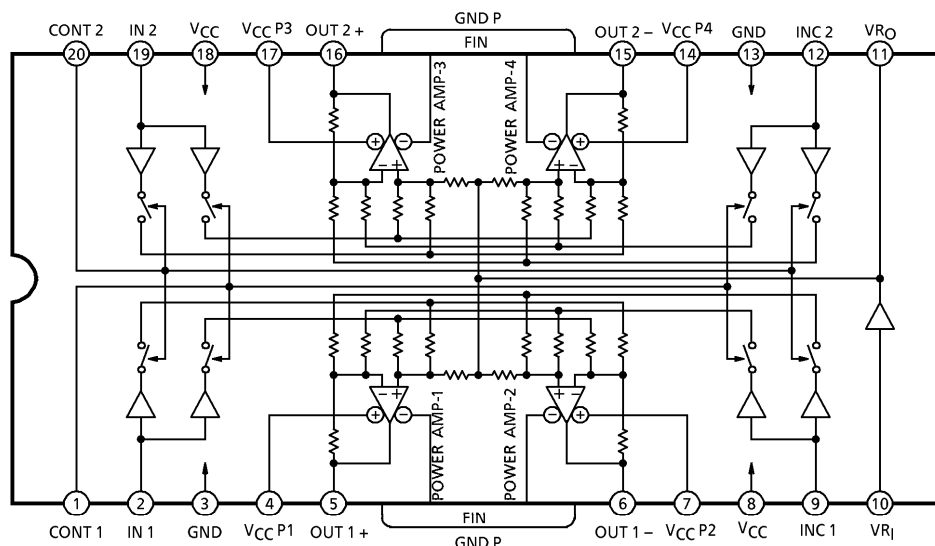

980508EBA2

● TOSHIBA is continually working to improve the quality and the reliability of its products. Nevertheless, semiconductor devices in general can malfunction or fail due to their inherent electrical sensitivity and vulnerability to physical stress. It is the responsibility of the buyer, when utilizing TOSHIBA products, to observe standards of safety, and to avoid situations in which a malfunction or failure of a TOSHIBA product could cause loss of human life, bodily injury or damage to property. In developing your designs, please ensure that TOSHIBA products are used within specified operating ranges as set forth in the most recent products specifications. Also, please keep in mind the precautions and conditions set forth in the TOSHIBA Semiconductor Reliability Handbook.

FUNCTION OF EACH PIN

PIN No.	SYMBOL	I/O	FUNCTION DESCRIPTION			REMARKS			
			CONT 1	CONT 2	Gain				
1	CONT 1	I	Input terminal for gain switch.						
							0	0	VR fixed
							1	0	2 times
							0	1	4 times
20	CONT 2								
			1	1	6 times				
2	IN 1	I	Control signal input terminal for power Amp-1 and 2.						
3	GND	—	Ground terminal.						
4	V <sub>CC</sub> P1	—	Power supply voltage terminal. (Power Amp-1)						
5	OUT 1 +	O	Power Amp-1 output terminal.						
6	OUT 1 -	O	Power Amp-2 output terminal.						
7	V <sub>CC</sub> P2	—	Power supply voltage terminal. (Power Amp-2)						
8	V <sub>CC</sub>	—	Power supply voltage terminal.						
9	INC 1	I	Control signal input terminal common to power Amp-1 and 2.						
10	VR <sub>I</sub>	I	Internal reference voltage terminal. Capacitor for filter is connected with GND.						
11	VR <sub>O</sub>	O	Reference voltage output terminal. VR <sub>O</sub> = VR <sub>I</sub>						
12	INC 2	I	Control signal input terminal common to power Amp-3 and 4.						
13	GND	—	Ground terminal.						
14	V <sub>CC</sub> P4	—	Power supply voltage terminal. (Power Amp-4)						
15	OUT 2 -	O	Power Amp-4 output terminal.						
16	OUT 2 +	O	Power Amp-3 output terminal.						
17	V <sub>CC</sub> P3	—	Power supply voltage terminal. (Power Amp-3)						
18	V <sub>CC</sub>	—	Power supply voltage terminal.						
19	IN 2	I	Control signal input terminal for power Amp-3 and 4.						
FIN	GND P	—	Heat sink and power ground terminal.						

980508EBA2

- The products described in this document are subject to foreign exchange and foreign trade laws.
- The information contained herein is presented only as a guide for the applications of our products. No responsibility is assumed by TOSHIBA CORPORATION for any infringements of intellectual property or other rights of the third parties which may result from its use. No license is granted by implication or otherwise under any intellectual property or other rights of TOSHIBA CORPORATION or others.
- The information contained herein is subject to change without notice.

## MAXIMUM RATINGS (Ta = 25°C)

CHARACTERISTIC	SYMBOL	RATING	UNIT
Power Supply Voltage	V <sub>CC</sub>	14	V
Output Current	I <sub>O</sub> (Typ.)	0.5	A
Power Dissipation	No Heat Sink	P <sub>D</sub>	W
	Heat Sink		
Operating Temperature	T <sub>opr</sub>	-25~75	°C
Storage Temperature	T <sub>stg</sub>	-55~150	°C

ELECTRICAL CHARACTERISTICS (Unless otherwise specified, V<sub>CC</sub> = 5V, Ta = 25°C, BTL connection)

CHARACTERISTIC	SYMBOL	TEST CIR-CUIT	TEST CONDITION	MIN.	TYP.	MAX.	UNIT	
Operating Power Supply Voltage	V <sub>CC</sub>	—	V <sub>CC</sub> , V <sub>CC</sub> P1 - V <sub>CC</sub> P4	4	5	12	V	
Power Supply Current	I <sub>CCQ</sub>	—	IN 1 = IN 2 = 2.1V INC 1 = INC 2 = 2.1V	2 times	16	30	mA	
				4 times	16			
				6 times	18			
Input Offset Current	I <sub>IO</sub>	—	IN 1 - INC 1, IN 2 - INC 2	—	10	100	nA	
Input Bias Current	I <sub>IB</sub>	—	IN 1, INC 1, IN 2, INC 2 terminals	—	500	1600	nA	
Output Offset Voltage	V <sub>OS</sub>	—	IN 1 = IN 2 = 2.1V INC 1 = INC 2 = 2.1V	V <sub>CC</sub> = 5V	10	30	mV	
				V <sub>CC</sub> = 8V	—	50		
				V <sub>CC</sub> = 12V	—	100		
Output Voltage	V <sub>O</sub>	—	f = 1kHz, R <sub>L</sub> = 5Ω	4.5	5.0	—	V <sub>p-p</sub>	
Voltage Gain	G <sub>V</sub>	—	f = 1kHz, R <sub>L</sub> = 5Ω V <sub>in</sub> = 100mV <sub>rms</sub>	2 times	4.5	5.0	6.5	dB
				4 times	10.5	11.0	12.5	
				6 times	14.5	15.0	16.5	
Frequency Band Range	f <sub>c</sub>	—	R <sub>L</sub> = 5Ω V <sub>in</sub> = 100mV <sub>rms</sub>	2 times	—	220	kHz	
				4 times	—	180		
				6 times	—	150		
Total Harmonic Distortion	THD	—	f = 1kHz, R <sub>L</sub> = 5Ω V <sub>in</sub> = 100mV <sub>rms</sub> V <sub>O</sub> = 4V <sub>p-p</sub>	2 times	—	-46	dB	
				4 times	—	-49		
				6 times	—	-51		
Slew Rate	SR	—	R <sub>L</sub> = 5Ω, V <sub>O</sub> = 2V <sub>p-p</sub>	2 times	—	1.5	V / μs	
				4 times	—	1.2		
				6 times	—	1.0		
Output Noise Voltage	V <sub>ON</sub>	—	R <sub>g</sub> = 10kΩ DIN AUDIO	2 times	—	15	μV <sub>rms</sub>	
				4 times	—	25		
				6 times	—	30		

CHARACTERISTIC		SYMBOL	TEST CIRCUIT	TEST CONDITION	MIN.	TYP.	MAX.	UNIT
Cross-talk	CT	—	f = 1kHz, R <sub>L</sub> = 5Ω V <sub>O</sub> = 1V <sub>rms</sub>	2 times	—	-88	—	dB
				4 times		-86		
				6 times		-80		
Ripple Rejection Ratio	RR	—	f <sub>R</sub> = 100Hz, 77.5mV <sub>rms</sub> (-20dBm)	2 times	—	-70	—	dB
				4 times		-66		
				6 times		-60		
Reference Output Voltage		V <sub>RO</sub>	—	V <sub>RO</sub> terminal, V <sub>RO</sub> = (V <sub>CC</sub> - V <sub>BE</sub> ) / 2	—	2.1	—	V
Input Voltage	"H" level	V <sub>IH</sub>	—	CONT 1, CONT 2 terminals	2.0	—	—	V
	"L" level	V <sub>IL</sub>				—		
Thermal Shutdown Operation Temperature		T <sub>ON</sub>	—		—	165	—	°C

HSOP 20 POWER DISSIPATION

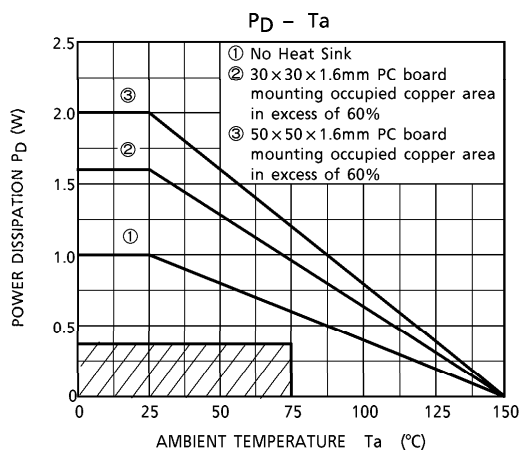

(Note) In case of normal use, power dissipation of IC only is oblique line portion.

TEST CIRCUIT / APPLICATION CIRCUIT

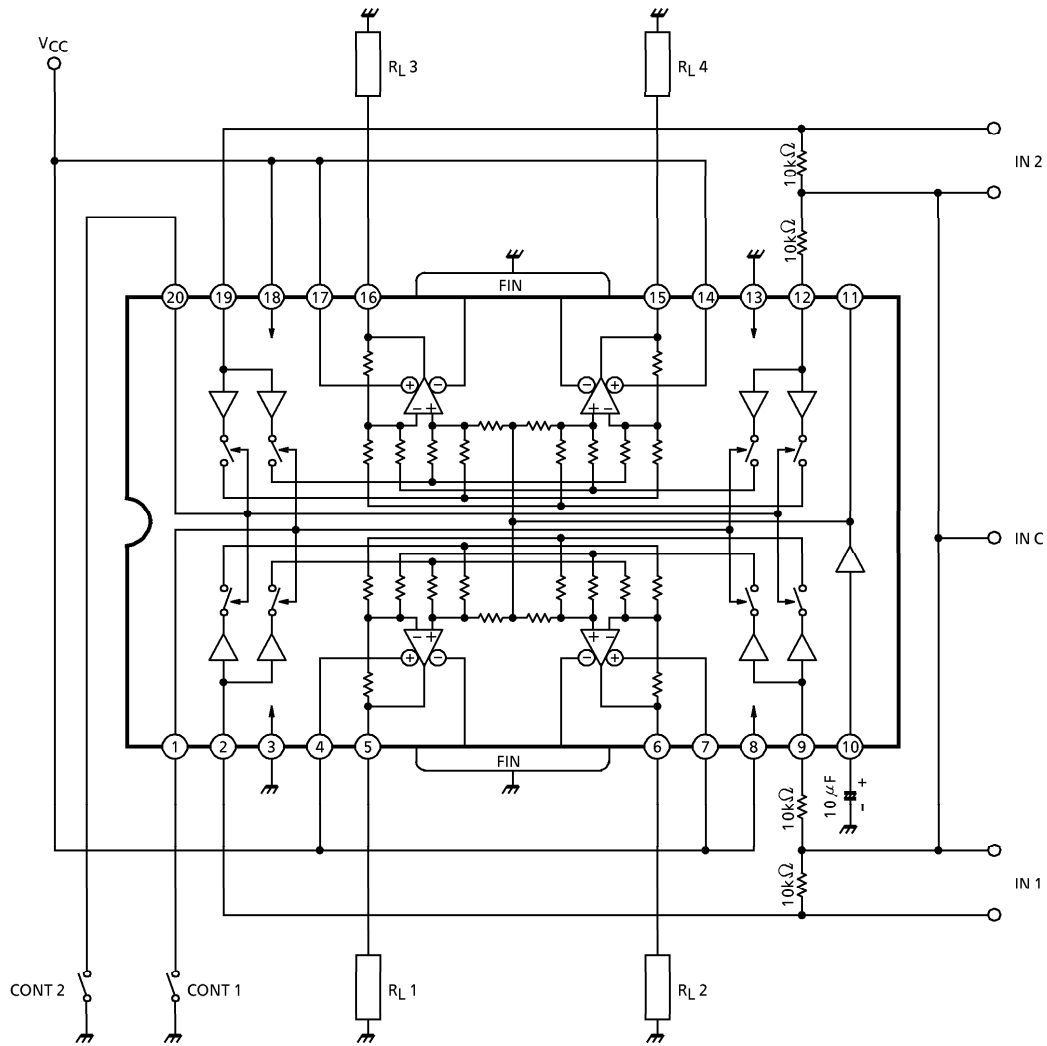

OUTLINE DRAWING  
HSOP20-P-450-1.00

Unit : mm

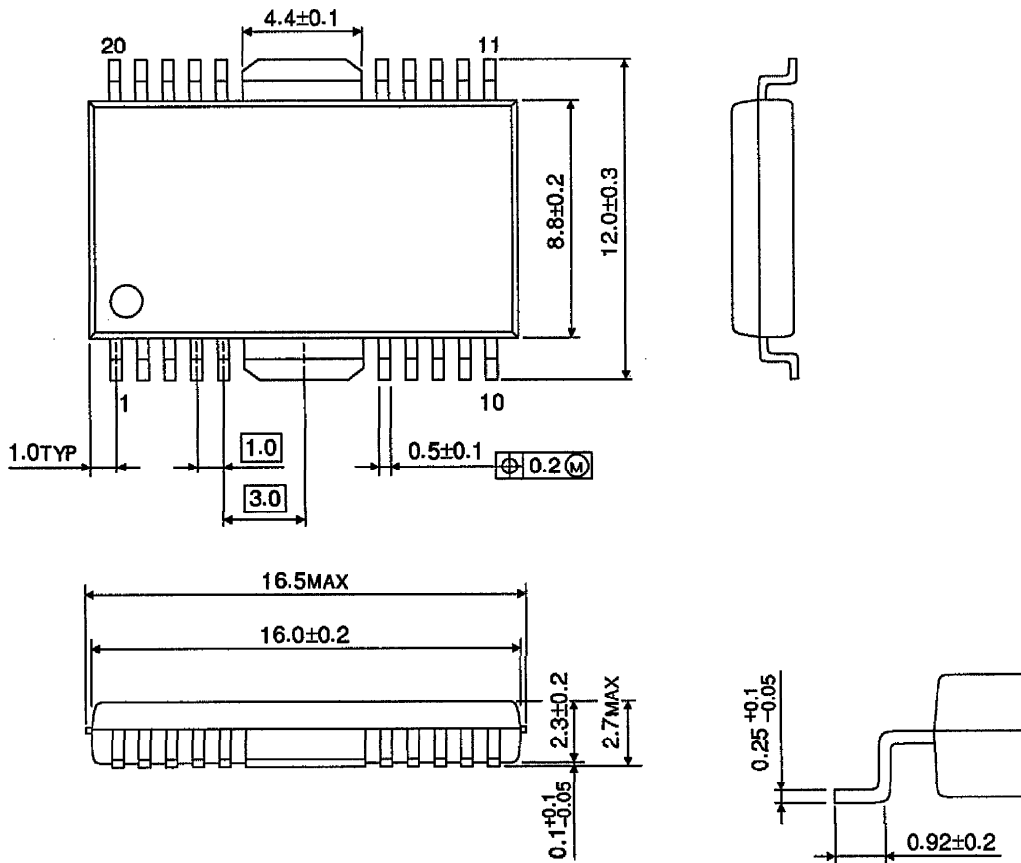

Weight : 0.8g (Typ.)