

## Features

- Microprocessor compatible control inputs
- On chip control memory and address decoding
- Row addressing
- Master reset
- 32 crosspoint switches in 8 x 4 array
- 5.0V to 15.0V operation
- Low crosstalk between switches
- Low on resistance: 90Ω (typ.) at 13V
- Matched switch characteristics
- Switches frequencies up to 40MHz

## Applications

- PABX and key systems
- Data acquisition systems
- Test equipment/instrumentation
- Analog/digital multiplexers

### Ordering Information

MT8804AC	24 Pin Ceramic DIP
MT8804AE	24 Pin Plastic DIP
MT8804AP	28 Pin PLCC
<b>-40° to 85° C</b>	

## Description

The MT8804A is a CMOS/LSI 8 x 4 Analog Switch Array incorporating control memory (32 bits), decoder and digital logic level converters. This circuit has digitally controlled analog switches having very low "ON" resistance and very low "OFF" leakage current. Switches will operate with analog signals at frequencies to 40 MHz and up to 15.0Vp-p. A "HIGH" on the Master Reset input switches all channels "OFF" and clears the memory. This device is ideal for crosspoint switching applications.

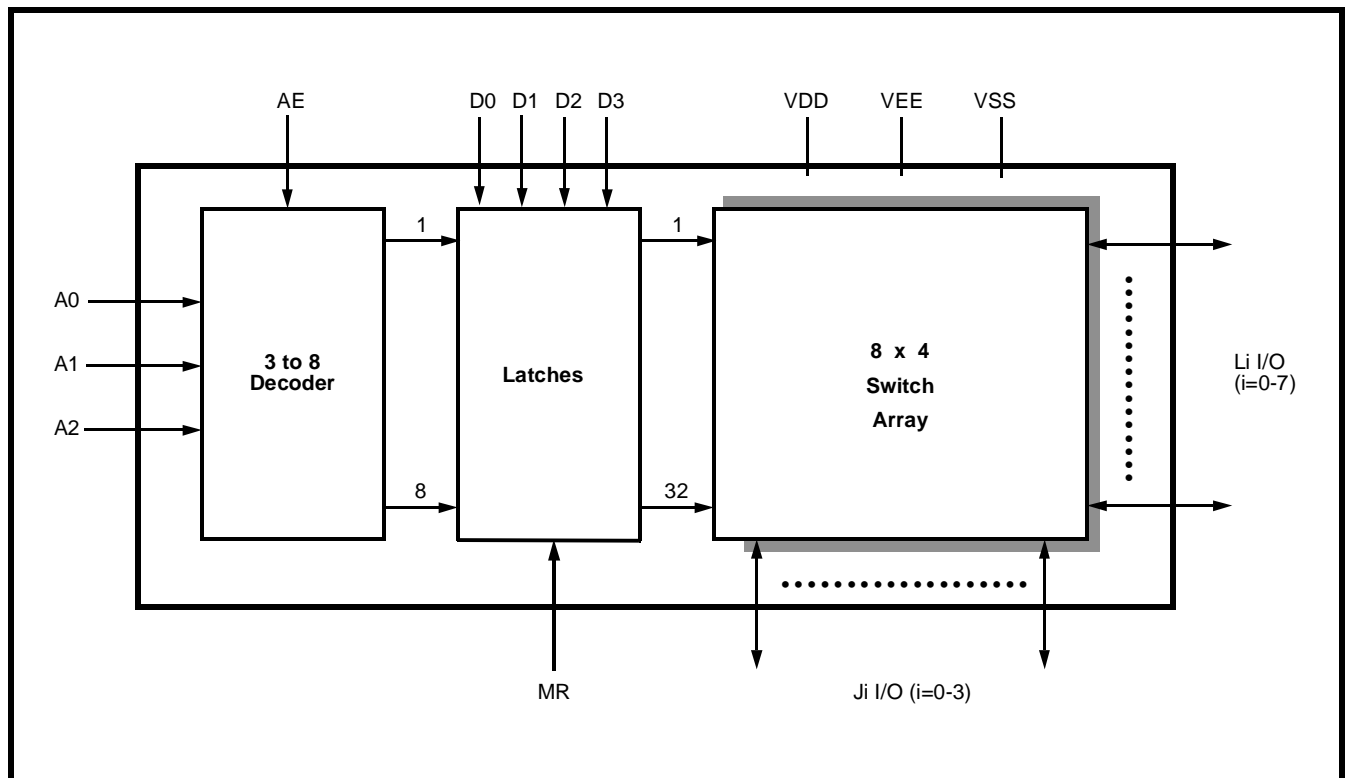

Figure 1 - Functional Block Diagram

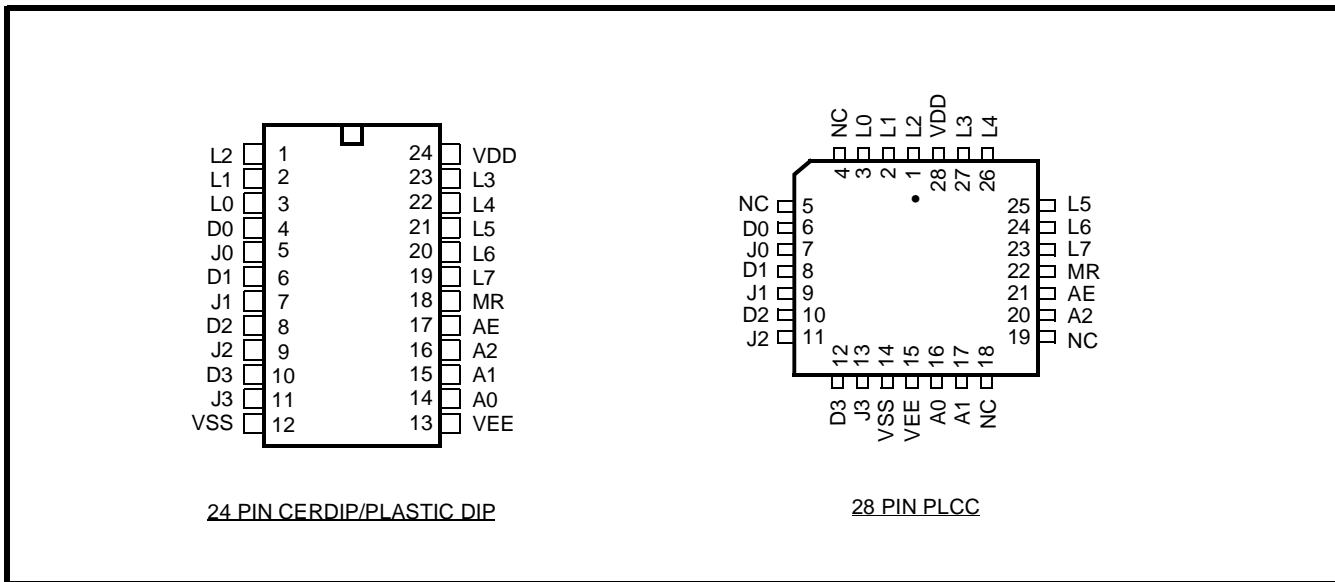

Figure 2 - Pin Connections

## Pin Description

Pin #*	Name	Description
1-3	L2-L0	<b>L2-L0 Analog Lines (Inputs/Outputs):</b> these are connected to the L2-L0 columns of the switch array.
4	D0	<b>D0 Data (Input):</b> Active High.
5	J0	<b>J0 Analog Junctor (Input/Output):</b> this is connected to the J0 row of the switch array.
6	D1	<b>D1 Data (Input).</b> Active High.
7	J1	<b>J1 Analog Junctor (Input/Output):</b> this is connected to the J1 row of the switch array.
8	D2	<b>D2 Data (Input):</b> Active High.
9	J2	<b>J2 Analog Junctor (Input/Output):</b> this is connected to the J2 row of the switch array.
10	D3	<b>D3 Data (Input):</b> Active High.
11	J3	<b>J3 Analog Junctor (Input/Output):</b> this is connected to the J3 row of the switch array.
12	V <sub>SS</sub>	<b>Digital Ground Reference.</b>
13	V <sub>EE</sub>	<b>Negative Power Supply.</b>
14-16	A0-A2	<b>A0-A2 Address Lines (Inputs).</b>
17	AE	<b>Address Enable/Strobe (Input):</b> enables function selected by address and data. Address must be stable before AE goes high and D0-D3 must be stable on the falling edge of the AE. Active High.
18	MR	<b>Master RESET (Input):</b> this is used to turn off all switches. Active High.
19-23	L7-L3	<b>L7-L3 Analog Lines (Inputs/Outputs):</b> these are connected to the L7-L3 columns of the switch array.
24	V <sub>DD</sub>	<b>Positive Power Supply.</b>

\* Plastic DIP and Cerdip only

## Functional Description

The MT8804A is a CMOS/LSI 8 X 4 Analog Switch Array incorporating an 8 X 4 analog switch array, address decoder, control memory, and digital logic level converter.

The analog switch array is arranged in 8 rows and 4 columns. The row input/outputs are referred to as Lines (L0-L7) and the column input/outputs as Junctors (J0-J3). The crosspoint analog switches interconnect the lines and junctors when turned "ON" and provide a high degree of isolation when turned "OFF". Interchannel crosstalk is minimal despite the high density of the analog switch array. The control memory of the MT8804A can be treated as an 8 word by 4 bit random access memory. The 8 words are selected by the ADDRESS (A0-A2) inputs through the on chip address decoder. Data is presented to the memory via the four DATA inputs (D0-D3). This data is asynchronously written into the control memory whenever the ADDRESS ENABLE (AE) input is HIGH. A HIGH level written into a memory cell turns the corresponding crosspoint switch "ON" while a LOW level causes the crosspoint to turn "OFF".

Only the crosspoint switches corresponding to the addressed memory word are affected when data is written into the memory. The remaining switches retain their previous states. By establishing appropriate patterns in the control memory, any combination of lines and junctors may be interconnected. A HIGH level on the MASTER RESET (MR) input returns all memory locations to a LOW level and turns all crosspoint switches "OFF" effectively isolating the lines from the junctors. The digital logic level converters allow the digital input levels to differ from limits of the analog levels switched through the array. For example, with

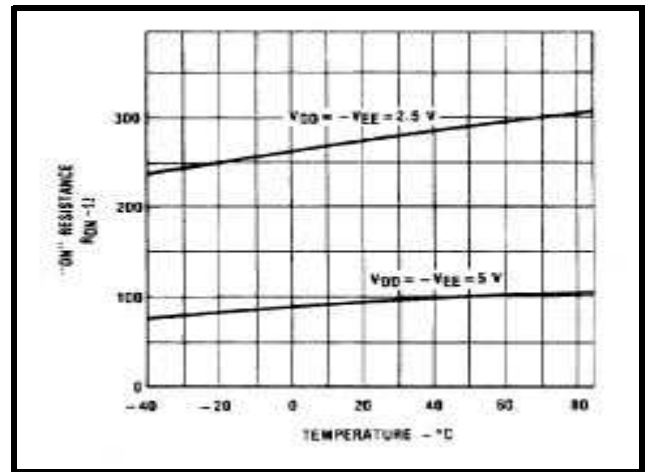

Figure 3 - On Resistance vs. Temperature (Input Signal Voltage=Supply Voltage/2)

$V_{DD}=5V$ ,  $V_{SS}=0V$  and  $V_{EE}=-6V$ , the control inputs can be driven by a 5V system while the analog voltages through the crosspoint switches can swing from +5V to -6V.

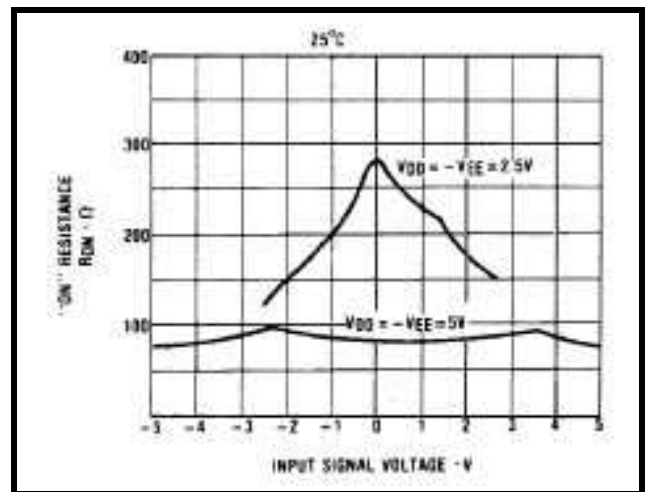

Figure 4 - On Resistance vs. Input Signal Voltage

### 8x8 Analog/Digital Switch

Two MT8804s configured as shown, implement an 8 x 8 analog/digital switch. The switch capacity can be expanded to an M x N array of inputs/outputs. Expansion in the M dimension is as shown with the MT8804A lines (L0-L7) commoned. Expansion in the N dimension is accomplished by replicating the circuit shown and connecting the MT8804A junctors (J0-J3) in common. The address and data control inputs of the MT8804A's can be connected in common for any size and switch provided that the address enable (AE) inputs are driven individually. A particular signal path is connected by setting up the appropriate signals or the address and data lines and taking the corresponding address enable input high. The master reset (MR), when taken high, disconnects all signal paths.

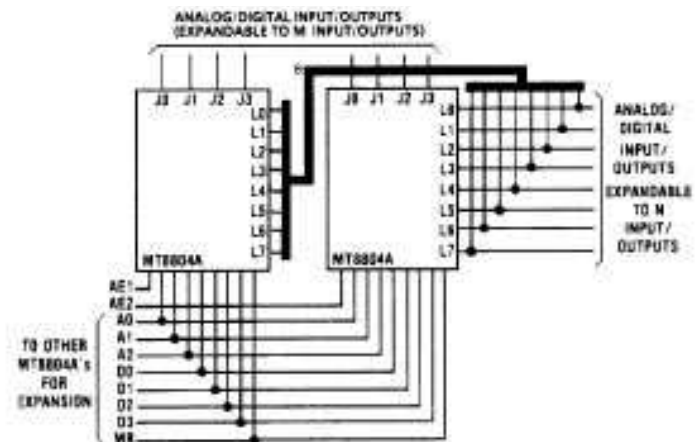

Figure 5 - 8 x 8 Analog/Digital Switch

## Absolute Maximum Ratings\* - Voltages are with respect to $V_{EE}$ unless otherwise stated.

	Parameter	Symbol	Min	Max	Units
1	Supply Voltage	$V_{DD}-V_{SS}$	-0.3	16	V
		$V_{DD}-V_{EE}$	-0.3	16	V
		$V_{SS}-V_{EE}$	-0.3	16	V
2	Analog Input Voltage	$V_{INA}$	$V_{EE}-0.3$	$V_{DD}+0.3$	V
3	Digital Input Voltage	$V_{IN}$	$V_{SS}-0.3$	$V_{DD}+0.3$	V
4	Current on any Logic Pin	I		10	mA
5	Storage Temperature	$T_S$	-65	+150	°C
6	Package Power Dissipation	PLASTIC DIP	$P_D$	0.6	W
		CERDIP	$P_D$	1.2	W

\* Exceeding these values may cause permanent damage. Functional operation under these conditions is not implied.

## Recommended Operating Conditions - Voltages are with respect to $V_{EE}$ unless otherwise stated.

	Characteristics	Sym	Min	Typ	Max	Units	Test Conditions
1	Operating Temperature	$T_O$	-40	25	85	°C	
2	Supply Voltage	$V_{DD}-V_{SS}$	5	5	15	V	
		$V_{DD}-V_{EE}$	5	10	15	V	
		$V_{SS}-V_{EE}$	0	5	10	V	
3	Analog Input Voltage	$V_{INA}$	$V_{EE}$		$V_{DD}$	V	
4	Digital Input Voltage	$V_{IN}$	$V_{SS}$		$V_{DD}$	V	

## DC Electrical Characteristics† - Voltages are with respect to $V_{EE}=V_{SS}=0V$ .

	Characteristics	Sym	Min	Typ‡	Max	Units	Test Conditions
1	Quiescent Supply Current	$I_{DD}$		1	100	µA	$V_{DD}=15V$ . All digital inputs at $V_{IN}=V_{SS}$ or $V_{DD}$
2	Off-state Leakage Current (Any line to any junctor)	$I_{OFF}$		±0.1	±500	nA	$V_{DD}=13V$ , Switch is 'Off' $ V_{Ji} - V_{Lj}  = V_{DD} - V_{EE}$
3	Input Logic "0" level	$V_{IL}$			3.0	V	$V_{DD} = 10V$ $V_{DD} = 5V$ $V_{INA} = V_{DD}$ through 1kΩ
					1.5	V	
4	Input Logic "1" level	$V_{IH}$	7.0	3.5		V	$V_{DD} = 10V$ $V_{DD} = 5V$ $V_{INA} = V_{DD}$ through 1kΩ
						V	
5	Maximum current through Crosspoint Switch	$I_{MAX}$			±8.0	mA	$V_{DD}=13V$

† DC Electrical Characteristics are at ambient temperature (25°C).

‡ Typical figures are for design aid only; not guaranteed and not subject to production testing.

## DC Electrical Characteristics- Switch Resistance - $V_{DC}$ is the external DC offset applied at the analog I/O pins.

	Characteristics	Sym	25° C			70° C	85° C	Units	Test Conditions
			Min	Typ	Max	Typ	Typ		
1	On-state Resistance $V_{DD}=13V$ $V_{DD}=10V$ $V_{DD}=5V$	$R_{ON}$	60	90	108	105	110	Ω	$V_{SS}=V_{EE}=0V, V_{DC}=V_{DD}/2,$ $ V_{Ji} - V_{Lj}  = 0.6V$
				105	160	120	125	Ω	
				290	650	320	325	Ω	
2	Difference in on-state resistance between two switches $V_{DD}=13V$ $V_{DD}=10V$	$\Delta R_{ON}$		20		20	20	Ω	$V_{SS}=V_{EE}=0V, V_{DC}=V_{DD}/2,$ $ V_{Ji} - V_{Lj}  = 0.6V$
				30		30	30	Ω	

**AC Electrical Characteristics† - Crosspoint Performance** -V<sub>DC</sub> is the external DC offset applied at the analog I/O pins. Voltages are with respect to V<sub>DD</sub>=10V, V<sub>SS</sub>=V<sub>EE</sub>=0V unless otherwise stated.

	Characteristics	Sym	Min	Typ‡	Max	Units	Test Conditions
1	Switch Line Capacitance	C <sub>IS</sub>		5		pF	
2	Switch Junctor Capacitance	C <sub>OS</sub>		20		pF	
3	Feedthrough Capacitance	C <sub>I</sub>		0.2		pF	
4	Frequency Response Channel "ON" 20LOG(V <sub>OUT</sub> / V <sub>INA</sub> ) = -3dB	F <sub>3dB</sub>		40		MHz	Switch is "ON"; V <sub>DC</sub> =5V, V <sub>INA</sub> =5Vpp sinewave f= 1kHz; R <sub>L</sub> = 1kΩ
5	Total Harmonic Distortion V <sub>DD</sub> =15V/V <sub>DC</sub> =7.5V V <sub>DD</sub> =10V/V <sub>DC</sub> =5V V <sub>DD</sub> =5V/V <sub>DC</sub> =2.5V	THD		0.1 0.2 1.0		% % %	Switch is "ON"; V <sub>EE</sub> =V <sub>SS</sub> =0V V <sub>INA</sub> =5Vpp sinewave f= 1kHz; R <sub>L</sub> = 10kΩ
6	Feedthrough Channel "OFF" Feed.=20LOG (V <sub>OUT</sub> / V <sub>INA</sub> )	FDT		-50		dB	All Switches "OFF"; V <sub>INA</sub> = 5Vpp sinewave f= 1MHz; R <sub>L</sub> = 1kΩ V <sub>DC</sub> =5V
7	Crosstalk between any two channels for switches Li - Ji and Lj - Jj.  Li - Ji is "ON" Lj - Jj is "OFF"  Xtalk=20LOG (V <sub>Jj</sub> /V <sub>Li</sub> ).	X <sub>talk</sub>		-40  -90		dB  dB	V <sub>INA</sub> =2Vpp sinewave f= 1.0MHz; R <sub>L</sub> = 600Ω.  V <sub>INA</sub> =2Vpp sinewave f= 3.4kHz; R <sub>L</sub> = 600Ω.  V <sub>DC</sub> = 5V
8	Propagation delay through switch	t <sub>PS</sub>		10		ns	C <sub>L</sub> =50pF

† AC Electrical Characteristics are at ambient temperature (25°C).

‡ Typical figures are for design aid only; not guaranteed and not subject to production testing.

**AC Electrical Characteristics† - Control and I/O Timings** - Voltages are with respect to V<sub>SS</sub>=V<sub>EE</sub>=0V unless otherwise stated.

	Characteristics	Sym	Min	Typ‡	Max	Units	Test Conditions
1	Digital Input Capacitance	C <sub>DI</sub>		5		pF	V <sub>DD</sub> =10V
2	Setup Time D0-D3 to AE	t <sub>DS</sub>	150 200			ns ns	V <sub>DD</sub> =10V V <sub>DD</sub> =5V
3	Hold Time D0-D3 to AE	t <sub>DH</sub>	120 300			ns ns	V <sub>DD</sub> =10V V <sub>DD</sub> =5V
4	Setup Time Address to AE	t <sub>AS</sub>	0 50			ns ns	V <sub>DD</sub> =10V V <sub>DD</sub> =5V
5	Hold Time Address to AE	t <sub>AH</sub>	120 300			ns ns	V <sub>DD</sub> =10V V <sub>DD</sub> =5V
6	AE Pulse Width	t <sub>AEW</sub>	100 250			ns ns	V <sub>DD</sub> =10V V <sub>DD</sub> =5V
7	AE to Switch Status Delay	t <sub>PAE</sub>		200 650	300 900	ns ns	V <sub>DD</sub> =10V V <sub>DD</sub> =5V See Note 1
8	DATA to Switch Status Delay	t <sub>PLH</sub> t <sub>PHL</sub>		250 650	400 1000	ns ns	V <sub>DD</sub> =10V V <sub>DD</sub> =5V See Note 1
9	MR to Switch Status Delay	t <sub>MR</sub>  t <sub>MRR</sub>		250 500 200 500	400 600 350 750	ns ns ns ns	V <sub>DD</sub> =10V V <sub>DD</sub> =5V V <sub>DD</sub> =10V V <sub>DD</sub> =5V See Note 2

† AC Electrical Characteristics are at ambient temperature (25°C).

‡ Typical figures are for design aid only; not guaranteed and not subject to production testing.

Note 1 R<sub>L</sub>= 10kΩ, C<sub>L</sub>=50pF

Note 2 R<sub>L</sub>= 1kΩ, C<sub>L</sub>=50pF

Digital Input rise time (tr) and fall time (tf) = 5ns.

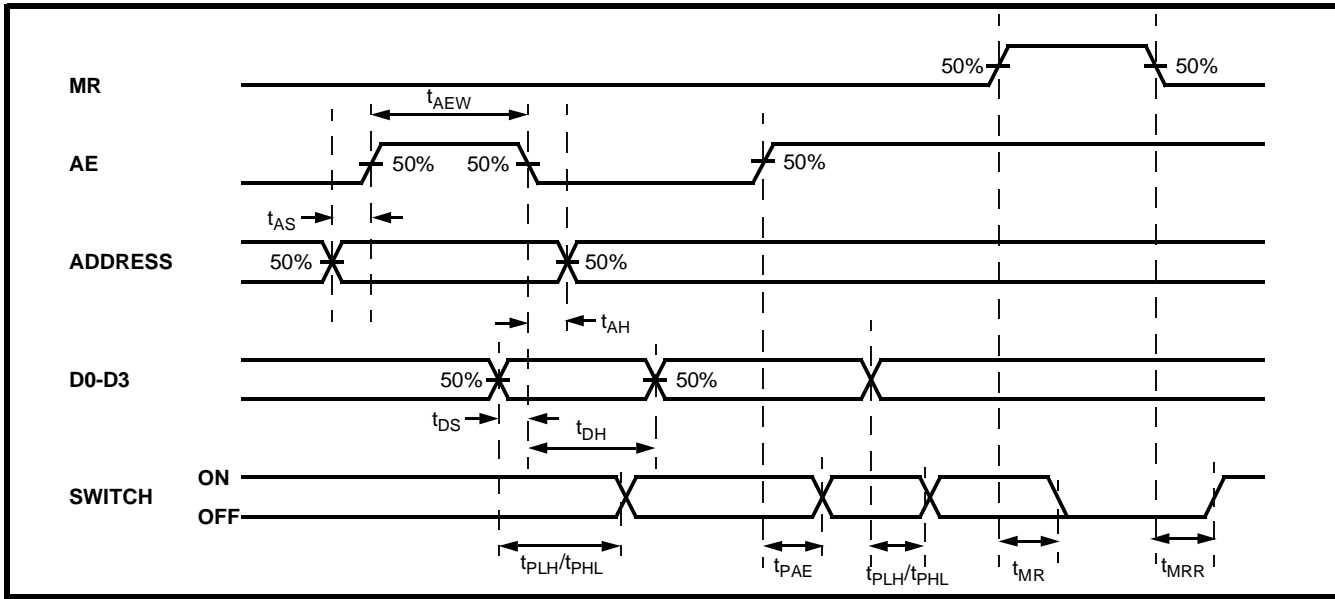

Figure 6 - Control Memory Timing Diagram

Memory Reset MR	Address Enable AE	Address			Addressed Line	Input Data To Control Memory				Junctors Connected To Addressed Line			
		A2	A1	A0		D3	D2	D1	D0	J3	J2	J1	J0
1	X	X	X	X	ALL	X	X	X	X	All Switches "OFF"			
0	0	X	X	X	NONE	X	X	X	X	No Change of State			
0	1	0	0	0	L0	0	0	0	0	•	•	•	•
0	1	0	0	0	L0	0	0	0	1	•	•	•	+
0	1	0	0	0	L0	0	0	1	0	•	•	+	+
0	1	0	0	0	L0	0	0	1	1	•	•	+	+
0	1	0	0	0	L0	0	1	0	0	•	+	•	•
0	1	0	0	0	L0	0	1	0	1	•	+	+	+
0	1	0	0	0	L0	0	1	1	0	•	+	+	•
0	1	0	0	0	L0	0	1	1	1	•	+	+	+
0	1	0	0	0	L0	1	0	0	0	+	•	•	•
0	1	0	0	0	L0	1	0	0	1	+	•	•	+
0	1	0	0	0	L0	1	0	1	0	+	•	+	•
0	1	0	0	0	L0	1	0	1	1	+	•	+	+
0	1	0	0	0	L0	1	1	0	0	+	+	•	•
0	1	0	0	0	L0	1	1	0	1	+	+	•	+
0	1	0	0	0	L0	1	1	1	0	+	+	+	•
0	1	0	0	0	L0	1	1	1	1	+	+	+	+
0	1	0	0	1	L1	0	0	0	0	•	•	•	•
↓	↓	↓	↓	↓	L1	↓	↓	↓	↓	↓	↓	↓	↓
0	1	0	0	1	L1	1	1	1	1	+	+	+	+
0	1	0	1	0	L2	0	0	0	0	•	•	•	•
↓	↓	↓	↓	↓	L2	↓	↓	↓	↓	↓	↓	↓	↓
0	1	0	1	0	L2	1	1	1	1	+	+	+	+
0	1	0	1	1	L3	0	0	0	0	•	•	•	•
↓	↓	↓	↓	↓	L3	↓	↓	↓	↓	↓	↓	↓	↓
0	1	0	1	1	L3	1	1	1	1	+	+	+	+
0	1	1	0	0	L4	0	0	0	0	•	•	•	•
↓	↓	↓	↓	↓	L4	↓	↓	↓	↓	↓	↓	↓	↓
0	1	1	0	0	L4	1	1	1	1	+	+	+	+
0	1	1	0	1	L5	0	0	0	0	•	•	•	•
↓	↓	↓	↓	↓	L5	↓	↓	↓	↓	↓	↓	↓	↓
0	1	1	0	1	L5	1	1	1	1	+	+	+	+
0	1	1	1	0	L6	0	0	0	0	•	•	•	•
↓	↓	↓	↓	↓	L6	↓	↓	↓	↓	↓	↓	↓	↓
0	1	1	1	0	L6	1	1	1	1	+	+	+	+
0	1	1	1	1	L7	0	0	0	0	•	•	•	•
↓	↓	↓	↓	↓	L7	↓	↓	↓	↓	↓	↓	↓	↓
0	1	1	1	1	L7	1	1	1	1	+	+	+	+

Table 1 - Address Decode Truth Table

- NOTES:
- 0 - Low Logic Level
  - 1 - High Logic Level
  - X - Don't Care Condition
  - + - Indicates Connection Between Junctor and Addressed Line
  - - Indicates No Connection Between Junctor and Addressed Line