

ASSP

BIPOLAR

Switching Regulator Controller

(4 Channels plus High-Precision, High-Frequency Capabilities)

MB3785A

■ DESCRIPTION

The MB3785A is a PWM-based 4-channel switching regulator controller featuring high-precision, high-frequency capabilities. All of the four channels of circuits allow their outputs to be set in three modes: step-down, step-up, and inverted. The third and fourth channels are suited for DC motor speed control.

The triangular-wave oscillation circuit accepts a ceramic resonator, in addition to the standard method of oscillation using an RC network.

■ FEATURES

- Wide range of operating power supply voltages: 4.5 V to 18 V
- Low current consumption: 6 mA [Typ.] when operating 10 μ A or less during standby
- Built-in high-precision reference voltage generator: 2.50 V \pm 1%
- Oscillation circuit
 - Capable of high-frequency oscillation: 100 kHz to 1 MHz
 - Also accepts a ceramic resonator.
- Wide input range of error amplifier: -0.2 V to $V_{CC}-1.8$ V
- Built-in timer/latch-actuated short-circuiting detection circuit
- Output circuit
 - The drive output for PNP transistors is the totem-pole type allowing the on-current and off-current values to be set independently.
- Adjustable dead time over the entire duty ratio range
- Built-in standby and output control functions
- High-density mounting possible: 48-pin LQFP package

■ PACKAGE

48-pin, Plastic LQFP

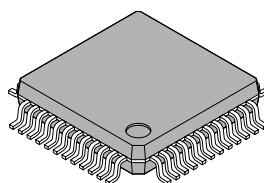

(FPT-48P-M05)

MB3785A

■ PIN ASSIGNMENT

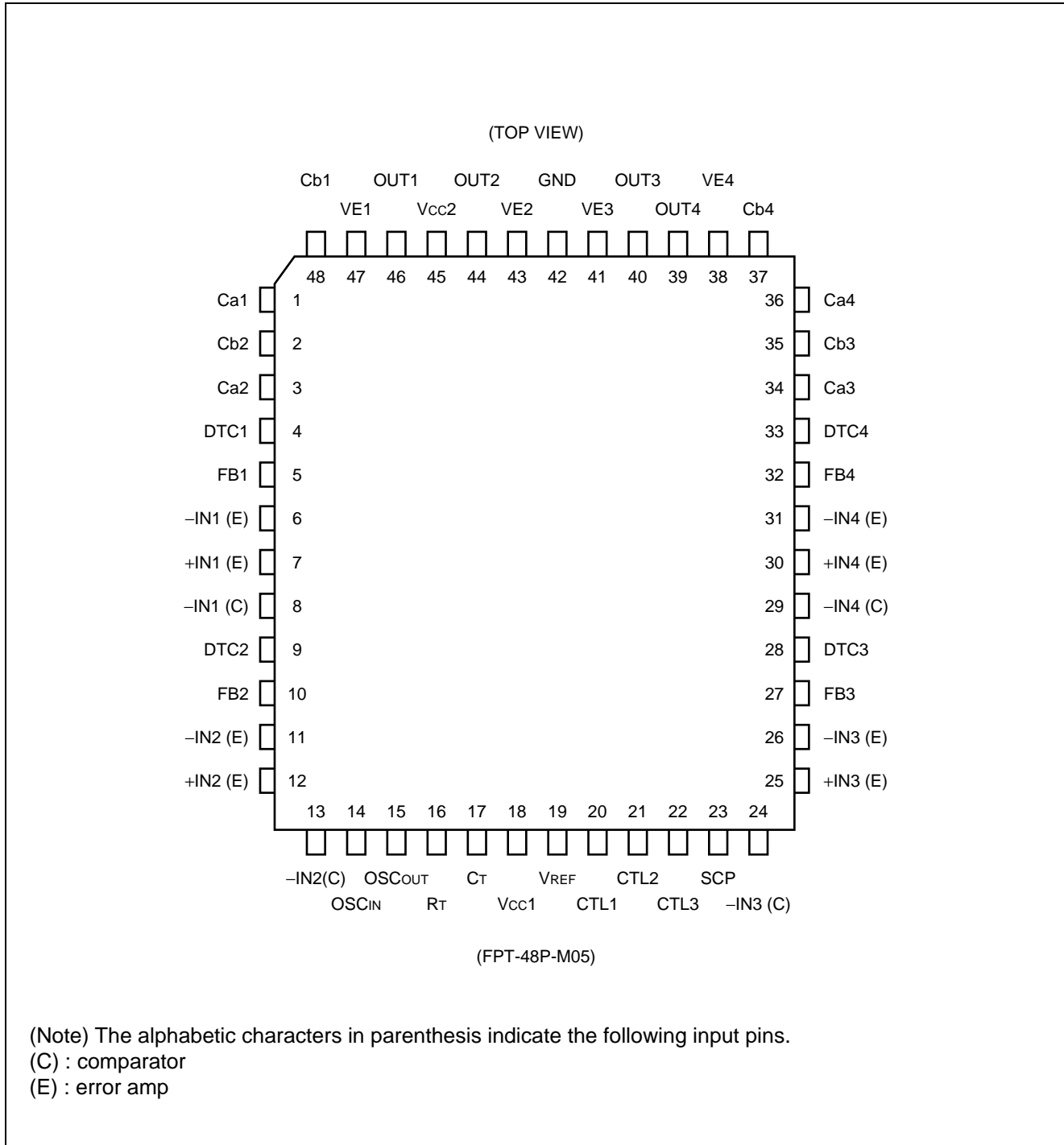

■ PIN DESCRIPTION

Pin No.	Symbol	I/O	Description
CH1	1	Ca1	CH1 output transistor OFF-current setting terminal. Insert a capacitor between the Ca1 and the Cb1 terminals, then set the output transistor OFF-current.
	48	Cb1	
	7	+IN1(E)	CH1 error amp non-inverted input terminal.
	6	-IN1(E)	CH1 error amp inverted input terminal.
	5	FB1	CH1 error amp output terminal.
	8	-IN1(C)	CH1 comparator inverted input terminal.
	4	DTC1	CH1 dead time control terminal.
	47	VE1	CH1 output current setting terminal.
	46	OUT1	CH1 totem-pole output terminal.
CH2	3	Ca2	CH2 output transistor OFF-current setting terminal. Insert a capacitor between the Ca2 and the Cb2 terminals, then set the output transistor OFF-current.
	2	Cb2	
	12	+IN2(E)	CH2 error amp non-inverted input terminal.
	11	-IN2(E)	CH2 error amp inverted input terminal.
	10	FB2	CH2 error amp output terminal.
	13	-IN2(C)	CH2 comparator inverted input terminal.
	9	DTC2	CH2 dead time control terminal.
	43	VE2	CH2 output current setting terminal.
	44	OUT2	CH2 totem-pole output terminal.
CH3	34	Ca3	CH3 output transistor OFF-current setting terminal. Insert a capacitor between the Ca3 and the Cb3 terminals, then set the output transistor OFF-current.
	35	Cb3	
	25	+IN3(E)	CH3 error amp non-inverted input terminal.
	26	-IN3(E)	CH3 error amp inverted input terminal.
	27	FB3	CH3 error amp output terminal.
	24	-IN3(C)	CH3 comparator inverted input terminal.
	28	DTC3	CH3 dead time control terminal.
	41	VE3	CH3 output current setting terminal.
	40	OUT3	CH3 totem-pole output terminal.
CH4	36	Ca4	CH4 output transistor OFF-current setting terminal. Insert a capacitor between the Ca4 and the Cb4 terminals, then set the output transistor OFF-current.
	37	Cb4	
	30	+IN4(E)	CH4 error amp non-inverted input terminal.
	31	-IN4(E)	CH4 error inverted input terminal.
	32	FB4	CH4 error amp output terminal.
	29	-IN4(C)	CH4 comparator inverted input terminal.

(Continued)

MB3785A

(Continued)

Pin No.	Symbol	I/O	Description	
CH4	33	DTC4	I	CH4 dead time control terminal.
	38	VE4	I	CH4 output current setting terminal.
	39	OUT4	O	CH4 totem-pole output terminal.
Triangular-Wave Oscillator Circuit	14	OSC _{IN}	—	This terminal connects a ceramic resonator.
	15	OSC _{OUT}	—	
	16	R _T	—	This terminal connects to a resistor for setting the triangular-wave frequency.
	17	C _T	—	This terminal connects to a capacitor for setting the triangular-wave frequency.
Power Supply Circuit	18	V _{CC1}	—	Power supply terminal for the reference power supply control circuit.
	45	V _{CC2}	—	Power supply terminal for the output circuit.
	42	GND	—	GND terminal.
	19	V _{REF}	O	Reference voltage output terminal.
Control Circuit	23	SCP	—	This terminal connects to a capacitor for the short-circuit protection circuit.
	20	CTL1	I	Power supply circuit and CH1 control terminal. <div style="border: 1px solid black; padding: 5px; margin-top: 5px;"> When this pin is High, the power supply circuit and first channel are in active state. When this pin is Low, the power supply circuit and first channel are in standby state. </div>
	21	CTL2	I	CH2 control terminal. While the CTL1 terminal is High <div style="border: 1px solid black; padding: 5px; margin-top: 5px;"> When this pin is High, the second channel is in active state. When this pin is Low, the second channel is in the inactive state. </div>
	22	CTL3	I	CH3 and CH4 control terminal. While the CTL1 terminal is High <div style="border: 1px solid black; padding: 5px; margin-top: 5px;"> When this pin is High, the third and fourth channels are in active state. When this pin is Low, the third and fourth channels are in the inactive state. </div>

■ BLOCK DIAGRAM

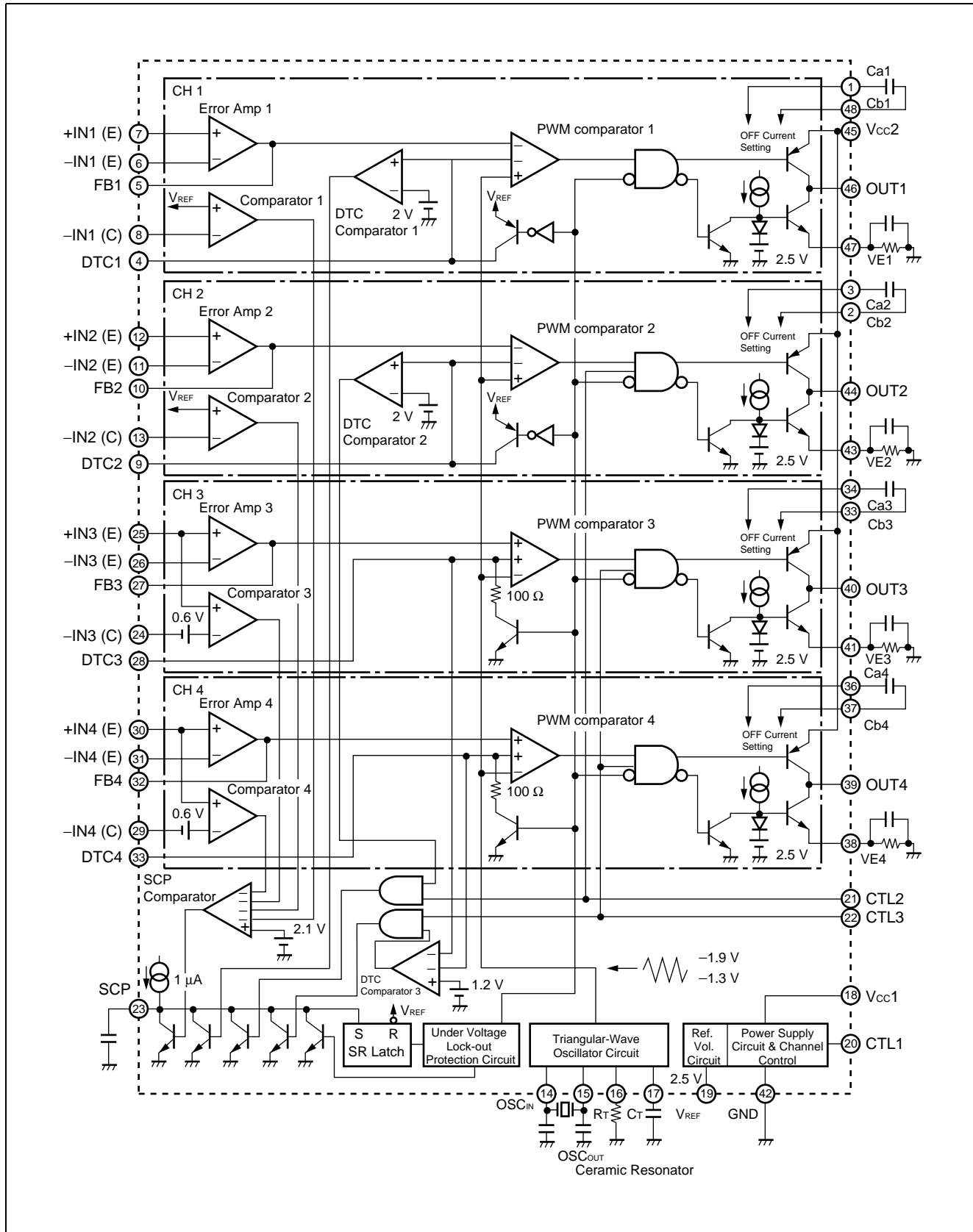

■ FUNCTIONAL DESCRIPTION

1. Switching Regulator Function

(1) Reference voltage circuit

The reference voltage circuit generates a temperature-compensated reference voltage (≈ 2.50 V) using the voltage supplied from the power supply terminal (pin 18). This voltage is used as the operating power supply for the internal circuits of the IC. The reference voltage can also be supplied to an external device from the V_{REF} terminal (pin 19).

(2) Triangular-wave oscillator circuit

By connecting a timing capacitor and a resistor to the C_T (pin 17) and the R_T (pin 16) terminals, it is possible to generate any desired triangular oscillation waveform. The oscillation can also be obtained by using a ceramic resonator connected to pins 14 and 15.

This waveform has an amplitude of 1.3 V to 1.9 V and is input to the internal PWM comparator of the IC. At the same time, it can also be supplied to an external device from the C_T terminal (pin 17).

(3) Error amplifier

This amplifier detects the output voltage of the switching regulator and outputs a PWM control signal accordingly. It has a wide common-mode input voltage range from -0.2 V to $V_{CC} - 1.8$ V and allows easy setting from an external power supply, making the system suitable for DC motor speed control.

By connecting a feedback resistor and capacitor from the error amplifier output pin to the inverted input pin, you can form any desired loop gain, for stable phase compensation.

(4) PWM comparator

- **CH1 & CH2**

The PWM comparators in these channels are a voltage comparator with two inverted input and one non-inverted input, that is, a voltage-pulse width converter to control the output pulse on-time according to the input voltage. It turns on the output transistor when the triangular wave from the oscillator is higher than both the error amplifier output and the DTC-pin voltages.

- **CH3 & CH4**

The PWM comparators in these channels are a voltage comparator with one inverted input and two non-inverted inputs, that is, a voltage-pulse width converter to control the output pulse on-time according to the input voltage. It turns on the output transistor when the triangular wave from the oscillator is lower than both the error amplifier output and the DTC-pin voltages.

These four channels can be provided with a soft start function by using the DTC pin.

(5) Output circuit

The output circuit is comprised of a totem-pole configuration and can drive a PNP transistor (30 mA Max.)

2. Channel Control Function

The MB3785A allows the four channels of power supply circuits to be controlled independently. Set the voltage levels on the CTL1 (pin 20), CTL2 (pin 21), and CTL3 (pin 22) terminals to turn the circuit of each channel "ON" or "OFF", as listed below.

Table 1 Channel by Channel On/Off Setting Conditions.

CTL pin voltage level			On/Off state of channel			
CTL1	CTL2	CTL3	Power supply circuit	CH1	CH2	CH3 and CH4
H	H	H	ON		ON	ON
		L				OFF
	L	H			OFF	ON
		L				OFF
L	X		Standby state*			

*: The power supply current value during standby is 10 μ A or less.

3. Protective Functions

(1) Timer/latch-actuated short-circuiting protection circuit

The SCP comparator checks the output voltage of each comparator which is used to detect the short-circuiting of output. When any of these comparators have an output voltage greater than or equal to 2.1 V, the timer circuit is activated and a protection enable capacitor externally fitted to the SCP terminal (pin 23) begins to charge.

If the comparator's output voltage is not restored to normal voltage level by the time the capacitor voltage has risen to the base-emitter junction voltage of the transistor, i.e., V_{BE} (≈ 0.65 V), the latch circuit is activated to turn off the output transistor while at the same time setting the duty (OFF) = 100 %.

When actuated, this protection circuit can be reset by turning on the power supply again.

(2) Under voltage lockout protection circuit

A transient state at power-on or a momentary drop of the power supply voltage causes the control IC to malfunction, resulting in system breakdown or deterioration. By detecting the internal reference voltage with respect to the power supply voltage, this protection circuit resets the latch circuit to turn off the output transistor and set the duty (OFF) = 100 %, while at the same time holding the SCP terminal (pin 23) at the "L". The reset is cleared when the power supply voltage becomes greater than or equal to the threshold voltage level of this protection circuit.

MB3785A

■ ABSOLUTE MAXIMUM RATINGS (See WARNING)

(Ta = +25°C)

Parameter	Symbol	Conditions	Rating		Unit
			Min.	Max.	
Power supply voltage	V _{CC}	—	—	20	V
Control input voltage	V _{ICTL}	—	—	20	V
Power dissipation	P _D	Ta ≤ +25°C	—	550*	mW
Operating ambient temperature	T _{OP}	—	-30	85	°C
Storage temperature	T _{stg}	—	-55	125	°C

*: The packages are mounted on the epoxy board (4 cm × 4 cm).

WARNING: Semiconductor devices can be permanently damaged by application of stress (voltage, current, temperature, etc.) in excess of absolute maximum ratings. Do not exceed these ratings.

■ RECOMMENDED OPERATING CONDITIONS

(Ta = +25°C)

Parameter	Symbol	Conditions	Value			Unit
			Min.	Typ.	Max.	
Power supply voltage*	V _{CC}	—	4.5	6.0	18	V
Error amp. input voltage	V _I	—	-0.2	—	V _{CC} - 0.8	V
Comparator input voltage	V _I	—	-0.2	—	V _{CC}	V
Control input voltage	V _{ICTL}	—	-0.2	—	18	V
Output current	I _O	—	3.0	—	30	mA
Timing capacitance	C _T	—	68	—	1500	pF
Timing resistance	R _T	—	5.1	—	100	kΩ
Oscillation frequency	f _{osc}	—	100	500	1000	kHz
Operating ambient temperature	T _{OP}	—	-30	25	85	°C

*: The minimum value of the recommended supply voltage is 3.6 V except when the device operates with constant output sink current.

WARNING: The recommended operating conditions are required in order to ensure the normal operation of the semiconductor device. All of the device's electrical characteristics are warranted when the device is operated within these ranges.

Always use semiconductor devices within their recommended operating condition ranges. Operation outside these ranges may adversely affect reliability and could result in device failure.

No warranty is made with respect to uses, operating conditions, or combinations not represented on the data sheet. Users considering application outside the listed conditions are advised to contact their FUJITSU representatives beforehand.

■ ELECTRICAL CHARACTERISTICS

(V_{CC} = +6 V, T_a = +25°C)

Parameter	Symbol	Conditions	Value			Unit		
			Min.	Typ.	Max.			
Reference voltage block	Reference voltage	V _{REF}	I _{OR} = -1 mA	2.475	2.500	2.525	V	
	Rate of changed in output voltage vs. Temperature	$\frac{\Delta V_{REF}}{V_{REF}}$	T _a = -30°C to +85°C	-2	±0.2	2	%	
	Input stability	Line	V _{CC} = 3.6 V to 18 V	-10	-2	10	mV	
	Load stability	Load	I _{OR} = -0.1 mA to -1 mA	-10	-3	10	mV	
	Sort-circuit output current	I _{OS}	V _{REF} = 2 V	-25	-8	-3	mA	
Under voltage lockout protection circuit (U.V.L.O)	Threshold voltage	V _{IH}	—	—	2.72	—	V	
		V _{IL}	—	—	2.60	—	V	
	Hysteresis width	V _{HYS}	—	80	120	—	mV	
	Reset voltage (V _{CC})	V _R	—	1.5	1.9	—	V	
Short-circuit detection comparator	CH 1/CH 2	Input threshold voltage	V _{th}	—	2.45	2.50	2.55	V
		Input bias current	I _{IB}	V _I = 0 V	-200	-100	—	nA
		Input voltage range	V _I	—	-0.2	—	V _{CC}	V
	CH 3/CH 4	Input offset voltage	V _{IO}	—	0.58	0.65	0.72	V
		Input bias current	I _{IB}	V _I = 0 V	-200	-100	—	nA
		Common mode input voltage range	V _{ICM}	—	-0.2	—	V _{CC} -0.8	V
Short circuit detection block	Threshold voltage	V _{IPC}	—	0.60	0.65	0.70	V	
	Input standby voltage	V _{STB}	—	—	50	100	mV	
	Input latch voltage	V _I	—	—	50	100	mV	
	Input source current	I _{lbp}	—	-1.4	-1.0	-0.6	μA	
Triangular waveform oscillator block	Oscillation frequency	f _{OSC}	C _T = 300 pF, R _T = 6.2 kΩ	450	500	550	kHz	
	Frequency stability (V _{CC})	$\Delta f/f_{dv}$	V _{CC} = 3.6 V to 18 V	—	±1	—	%	
	Frequency stability (T _a)	$\Delta f/f_{dT}$	T _a = -30°C to +85°C	-4	—	4	%	

(Continued)

MB3785A

(Continued)

($V_{CC} = +6\text{ V}$, $T_a = +25^\circ\text{C}$)

Parameter		Symbol	Conditions	Value			Unit
				Min.	Typ.	Max.	
Error amplifier	Input offset voltage	V_{IO}	$V_{FB} = 1.6\text{ V}$	-10	—	10	mV
	Input bias current	I_{IB}	$V_{FB} = 1.6\text{ V}$	-200	-100	—	nA
	Common mode input voltage range	V_{ICM}	—	-0.2	—	$V_{CC}-0.8$	V
	Voltage gain	A_V	—	60	100	—	dB
	Frequency bandwidth	BW	$A_V = 0\text{ dB}$	—	800	—	kHz
CH 1/ CH 2 dead time control circuit	Input threshold voltage	V_{I0}	Duty cycle = 0 %	—	1.9	2.25	V
		V_{I100}	Duty cycle = 100 %	1.05	1.3	—	V
	Input bias current	I_{Ibd}	$V_{dt} = 2.3\text{ V}$	—	0.1	0.5	μA
	Latch mode source current	I_{ldt}	$V_{dt} = 1.5\text{ V}$	—	-500	-80	μA
	Latch input voltage	V_{ldt}	$I_{dt} = -40\text{ }\mu\text{A}$	$V_{REF}-0.3$	2.4	—	V
CH 3/ CH 4 dead time control circuit	Input threshold voltage	V_{I0}	Duty cycle = 0 %	1.05	1.3	—	V
		V_{I100}	Duty cycle = 100 %	—	1.9	2.25	V
	Input bias current	I_{Ibd}	$V_{dt} = 2.3\text{ V}$	—	0.1	0.5	μA
	Latch mode source current	I_{ldt}	$V_{dt} = 1.5\text{ V}$	80	500	—	μA
	Latch input voltage	V_{ldt}	$I_{dt} = +40\text{ }\mu\text{A}$	—	0.2	0.3	V
Channel control block	Threshold voltage	V_{th}	—	0.7	1.4	2.1	V
	Input current	I_{IH}	$V_{CTL} = 5\text{ V}$	—	100	200	μA
		I_{IL}	$V_{CTL} = 0\text{ V}$	-10	—	10	μA
Output block	Source current	I_o	—	—	-40	—	mA
	Sink current	I_o	$R_E = 82\text{ }\Omega$	18	30	42	mA
	Output leakage current	I_{LO}	$V_o = 18\text{ V}$	—	—	20	μA
General	Standby current	I_{CC0}	—	—	0	10	μA
	Supply current when output off	I_{CC}	—	—	6	8.6	mA

TYPICAL CHARACTERISTIC CURVES

1. Supply current vs. Supply voltage

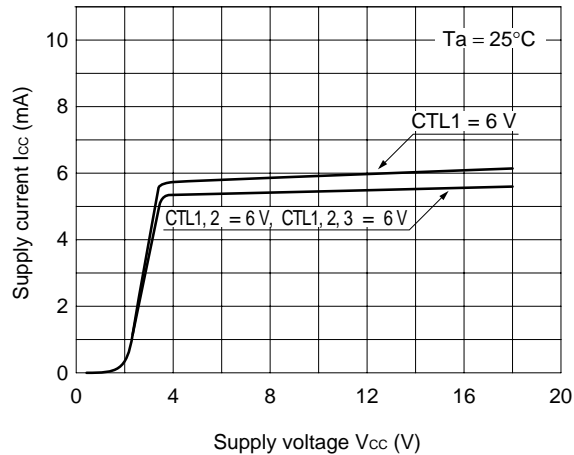

2. Reference voltage vs. Supply voltage

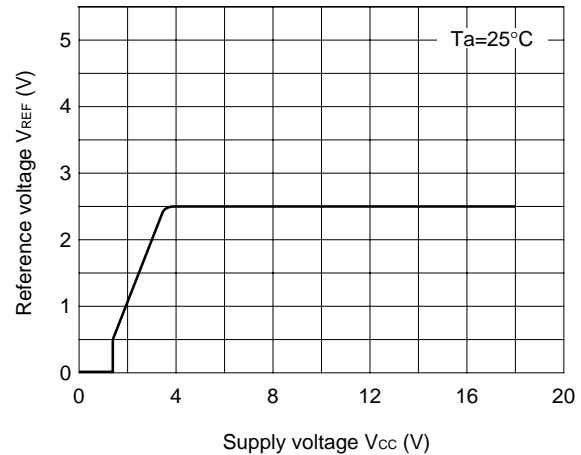

3. Reference voltage and Output current setting pin voltage vs. Supply voltage

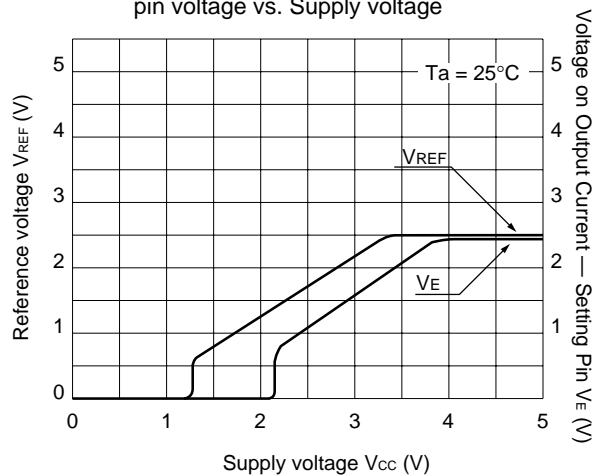

4. Reference voltage vs. Ambient temperature

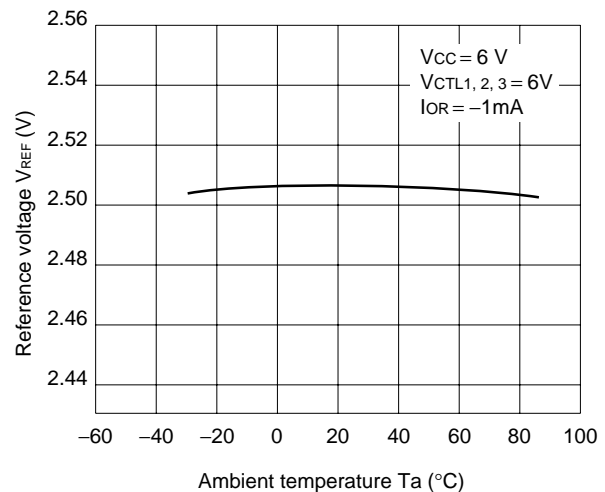

5. Reference voltage vs. Control voltage

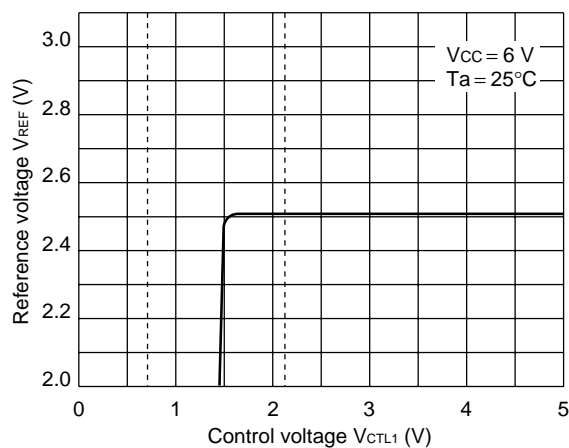

6. Control current vs. Control voltage

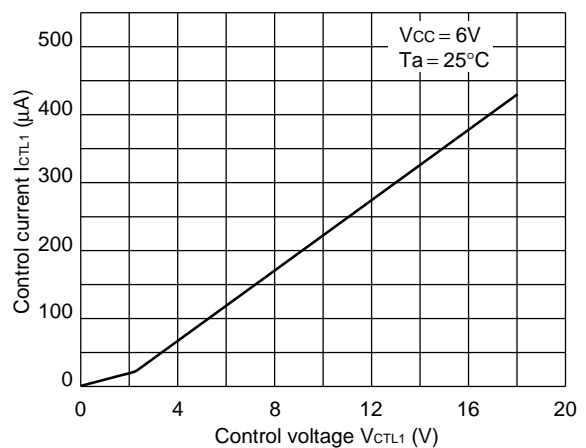

(Continued)

(Continued)

7. Triangular wave maximum amplitude voltage vs. Timing capacitance

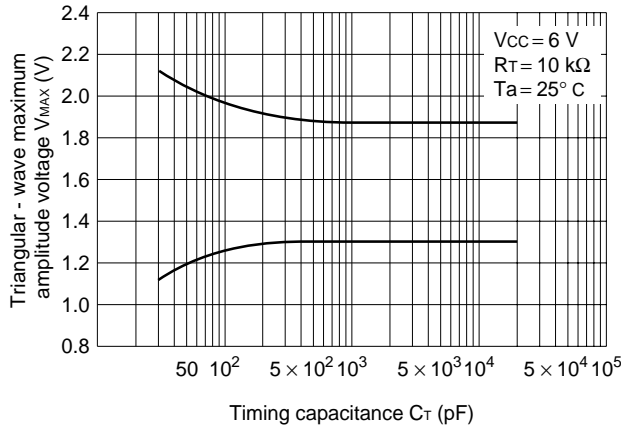

8. Triangular wave frequency vs. Timing resistance

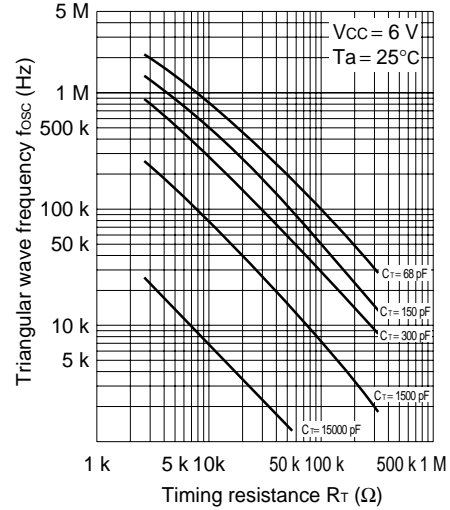

9. Triangular wave cycle vs. Timing capacitance

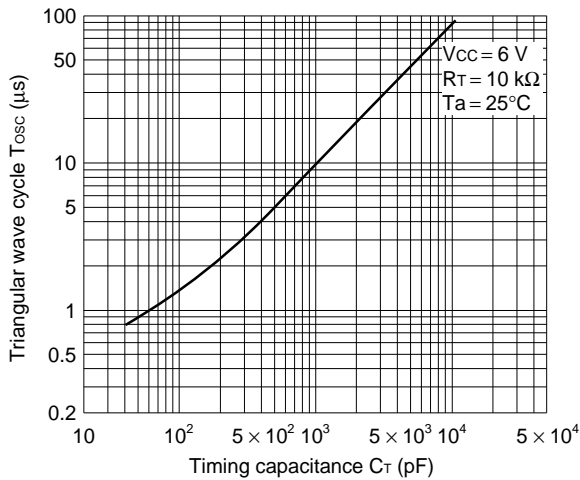

10. Duty vs. Triangular wave frequency

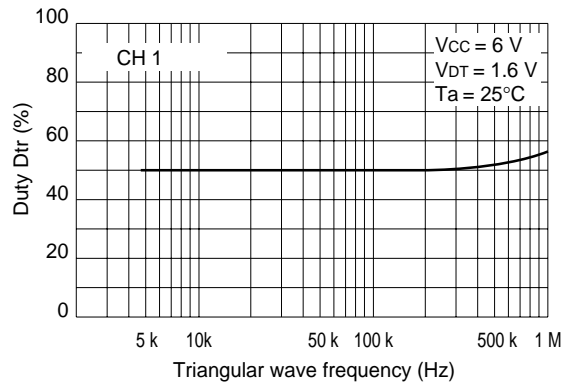

11. Rate of change in triangular wave frequency vs. Ambient temperature (Not using ceramic resonator)

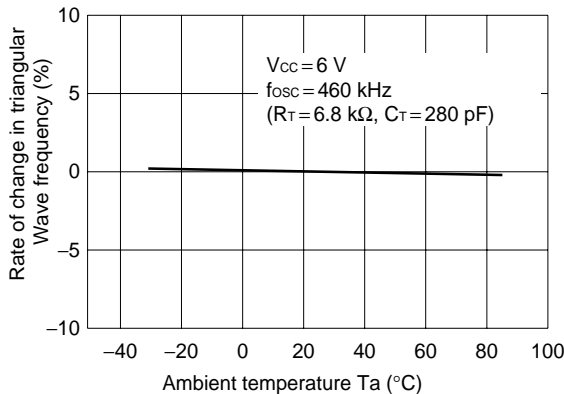

12. Rate of change in triangular wave frequency vs. Ambient temperature (Using ceramic resonator)

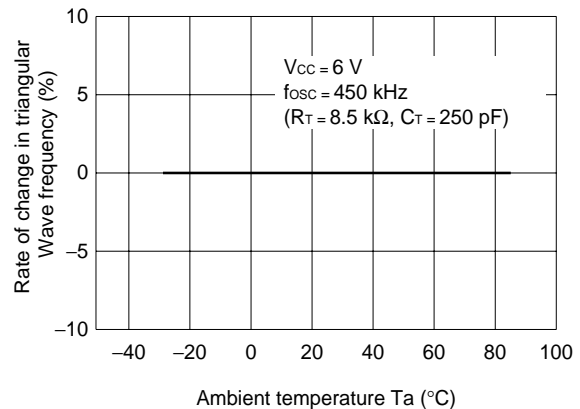

(Continued)

(Continued)

13. Gain vs. Frequency and Phase vs. Frequency

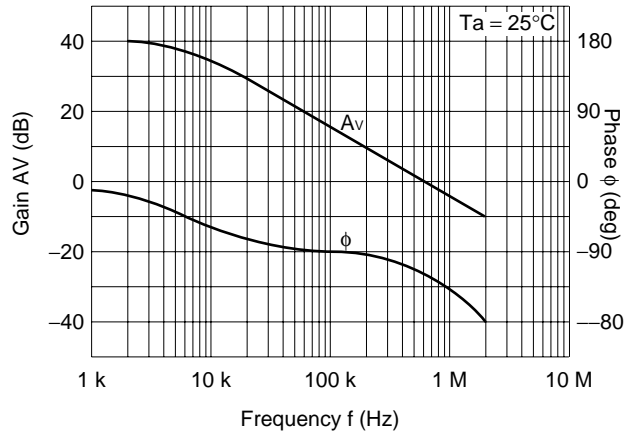

14. Error amp maximum output voltage vs. Frequency

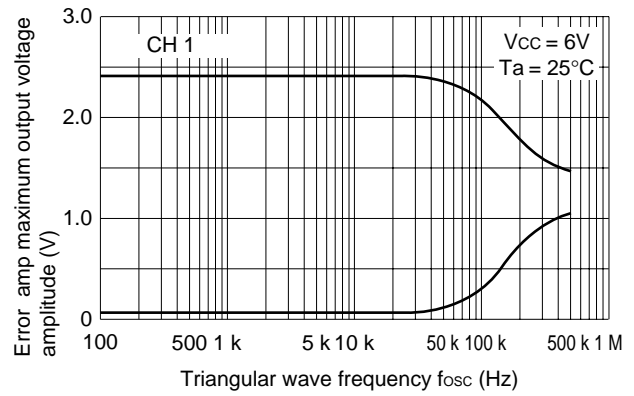

[Measuring Circuit]

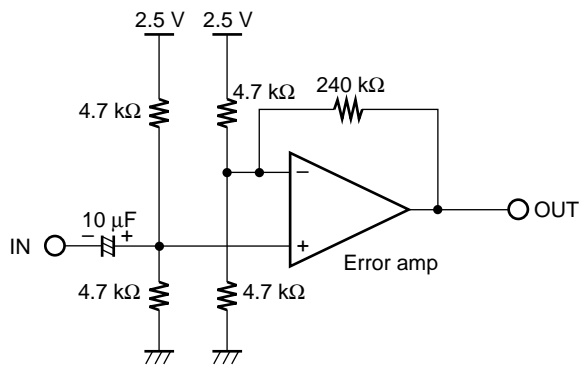

15. Power dissipation vs. Ambient temperature

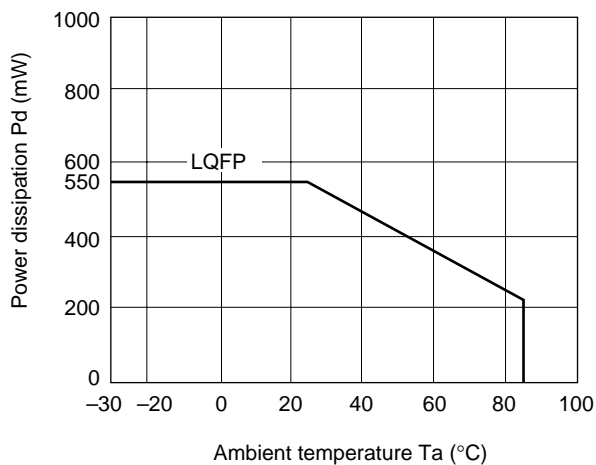

■ METHODS OF SETTING THE OUTPUT VOLTAGE

1. Method of Connecting CH1 and CH2: When Output Voltage (V_o) is Positive

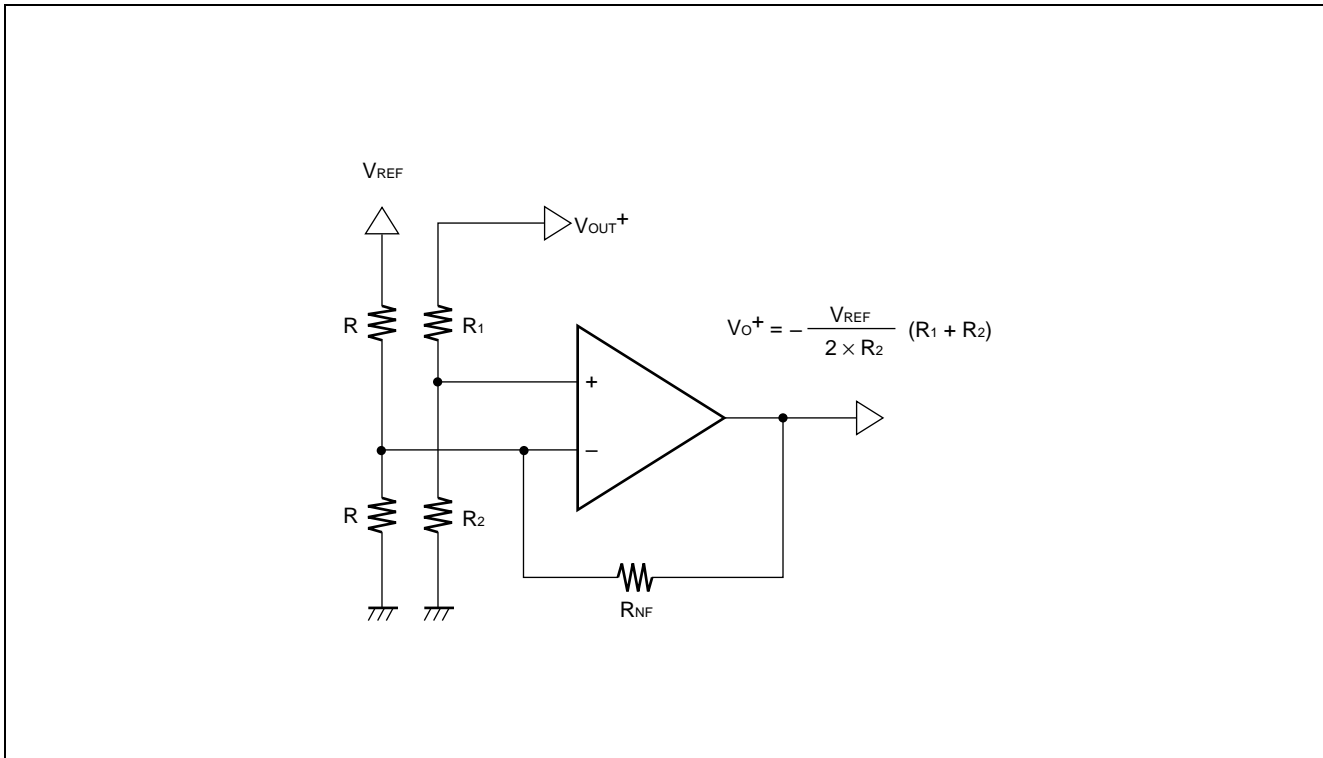

2. Method of Connecting CH1 and CH2: When Output Voltage (V_o) is Negative

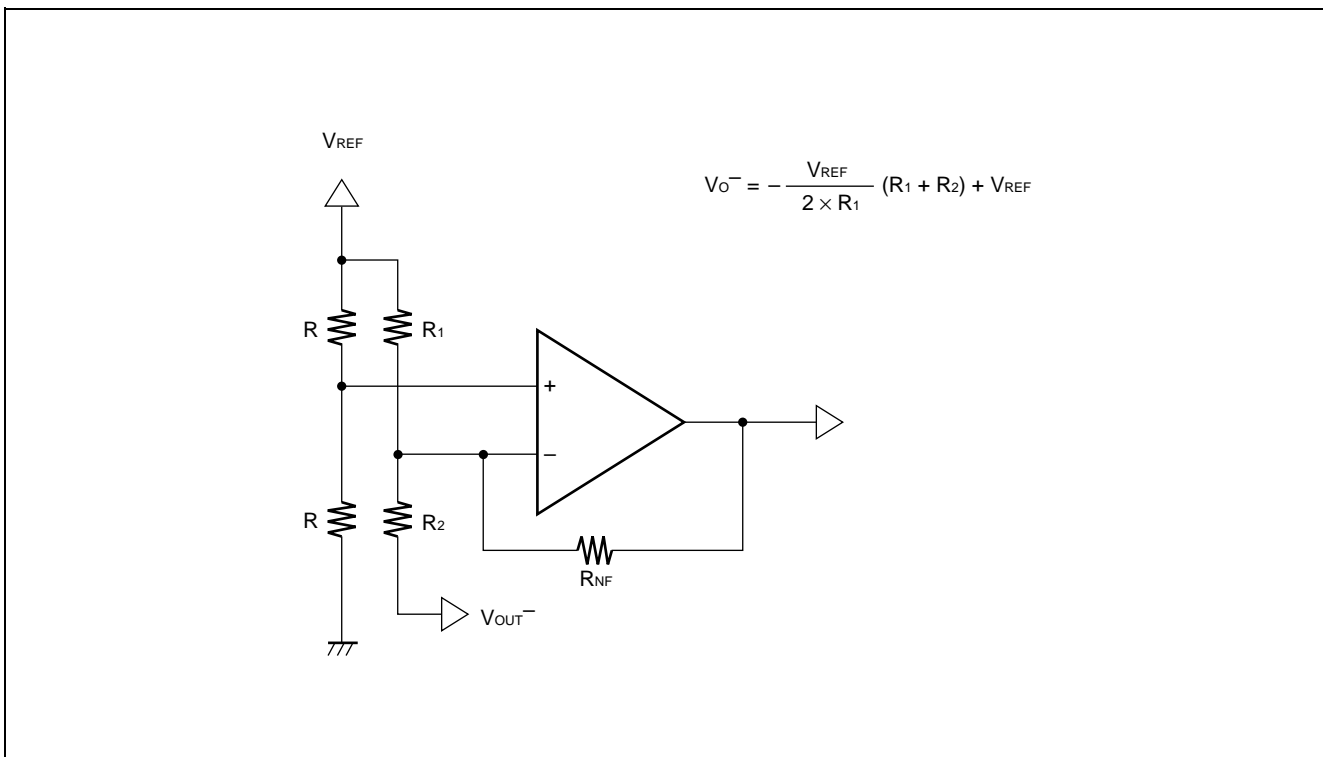

3. Method of Connecting CH3 and CH4: When Output Voltage (V_o) is Positive

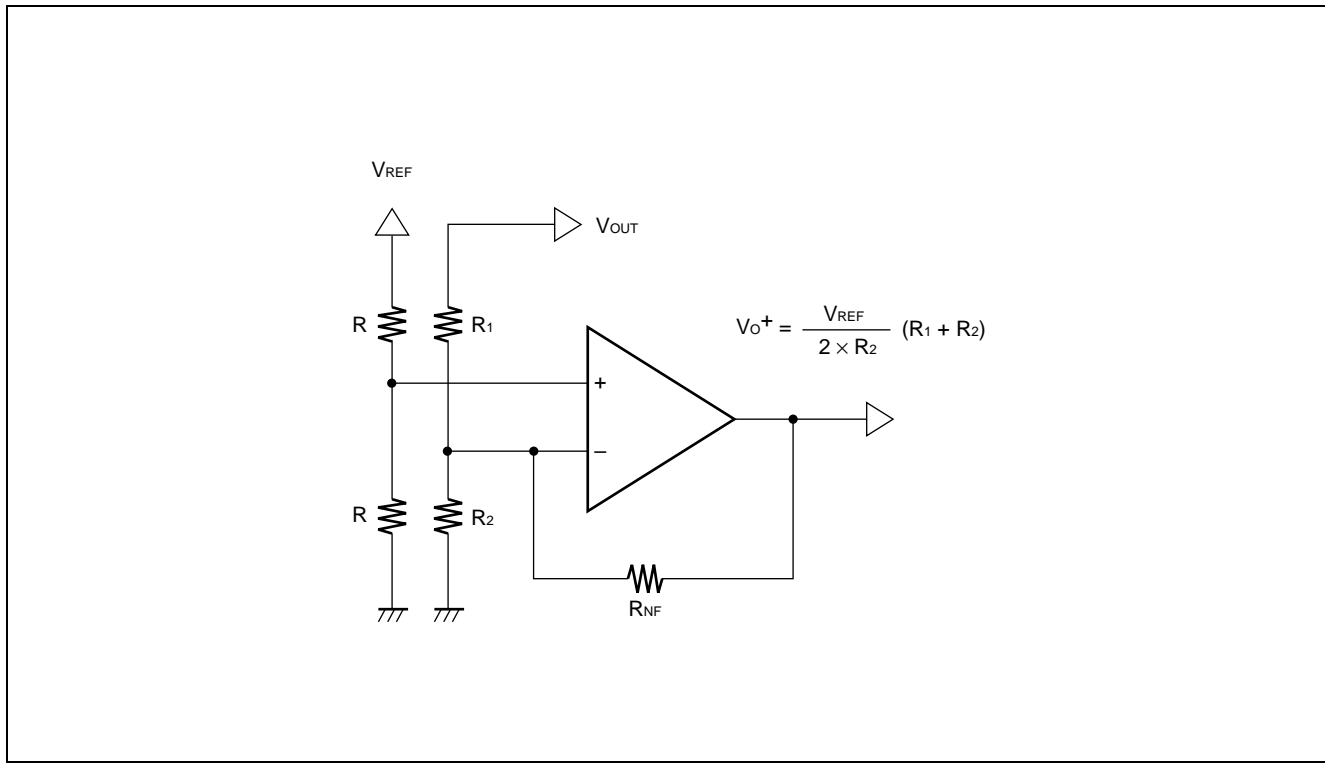

4. Method of Connecting CH3 and CH4: When Output Voltage (V_o) is Negative

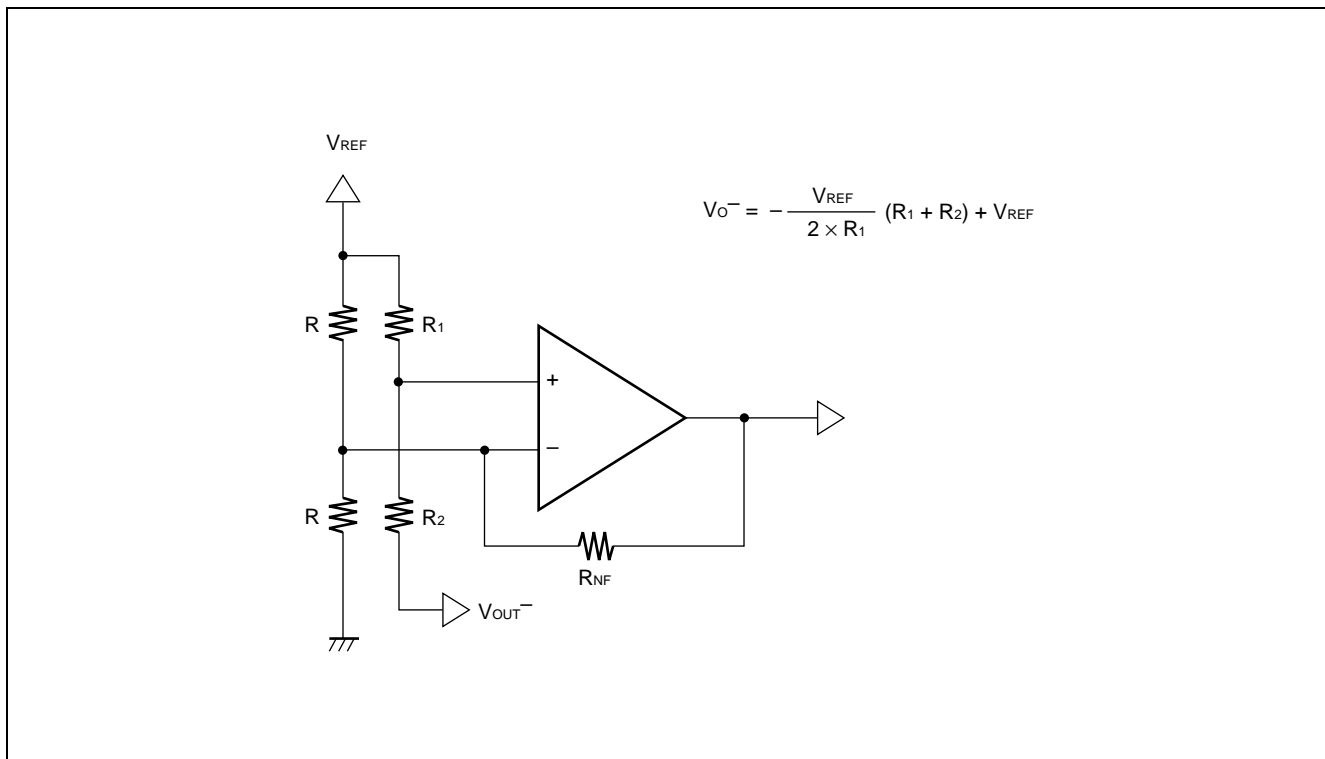

METHOD OF SETTING THE OUTPUT CURRENT

The output circuit is comprised of a totem-pole configuration. Its output current waveform is such that the ON-current value is set by constant current and the OFF-current value is set by a time constant as shown in Figure 2. These output currents are set using the equations below.

- ON-current = $2.5/R_E$ [A]
(Voltage on output current-setting pin $V_E \approx 2.5$ V)
- OFF-current time constant \approx proportional to the value of C_B

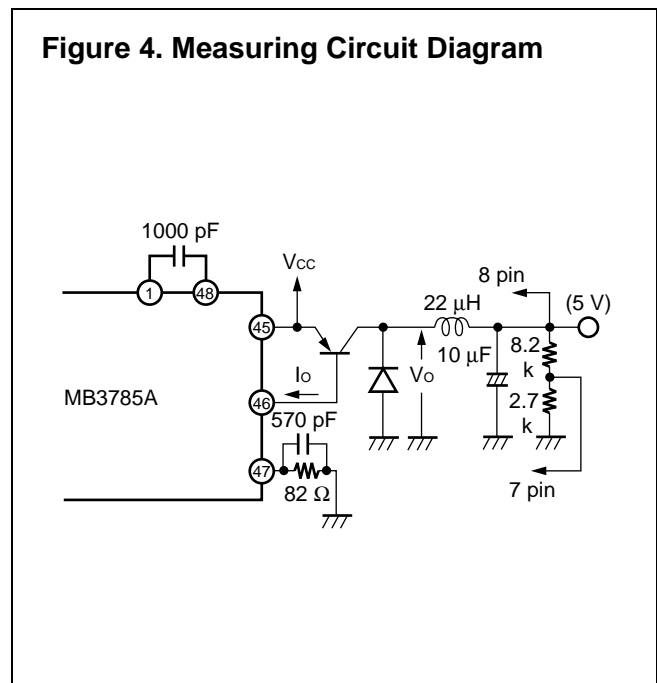
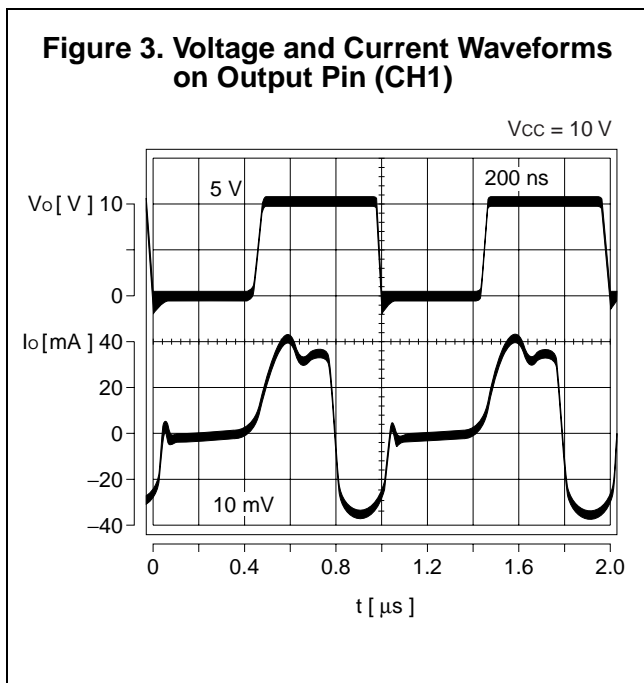
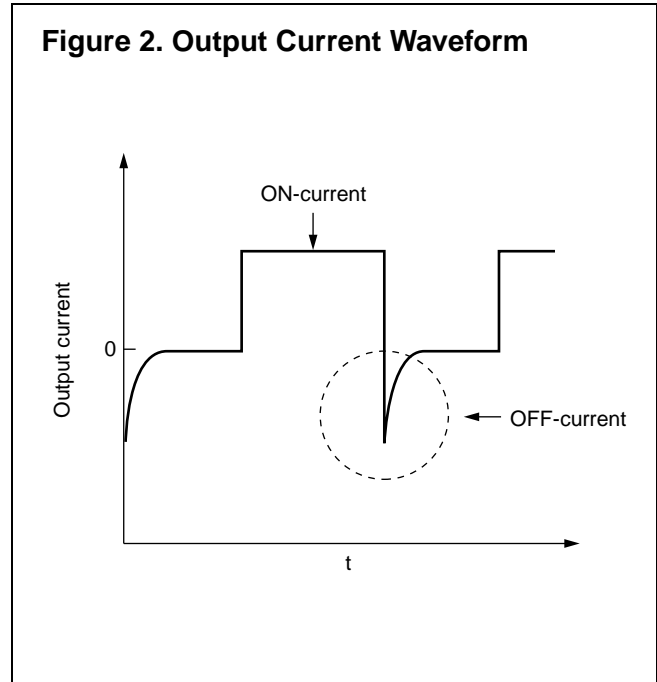
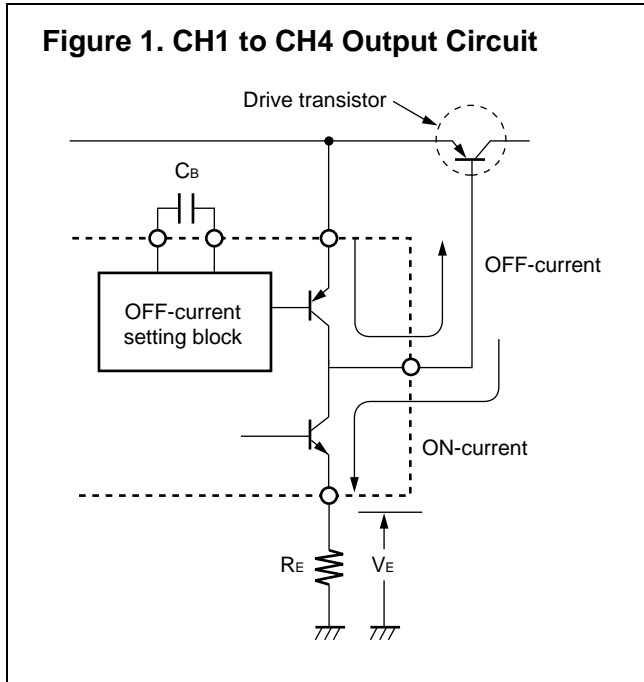

METHOD OF SETTING TIME CONSTANT FOR TIMER/LATCH-ACTUATED SHORT-CIRCUITING PROTECTION CIRCUIT

Figure 5 schematically shows the protection latch circuit.

The outputs from the output-shorting detection comparators 1 to 4 are respectively connected to the inverted inputs of the SCP comparator. These inputs are always compared with the reference voltage of approximately 2.1 V which is fed to the non-inverted input of the SCP comparator.

While the switching regulator load conditions are stable, there are no changes in the outputs of the comparators 1 to 4 so that short-circuit protection control keeps equilibrium state. At this time, the voltage on the SCP terminal (pin 23) is held at approximately 50 mV.

When load conditions change rapidly due to a short-circuiting of load, for example, the output voltage of the comparator for the relevant channel goes "H" (2.1 V or more). Consequently, the SCP comparator outputs a "L", causing the transistor Q_1 to turn off, and the short-circuit protection capacitor C_{PE} (externally fitted to the SCP terminal) begins to charge.

$$V_{PE} = 50 \text{ mV} + t_{PE} \times 10^{-6}/C_{PE}$$

$$0.65 = 50 \text{ mV} + t_{PE} \times 10^{-6}/C_{PE}$$

$$C_{PE} = t_{PE}/0.6 \text{ (s)}$$

When the external capacitor C_{PE} is charged to approximately 0.65 V, the SR latch is set and the output drive transistor is turned off. Simultaneously, the dead time is extended to 100% and the output voltage on the SCP terminal (pin 23) is held "L". As a result, the S-R latch input is closed and C_{PE} is discharged.

Figure 5. Protection Latch Circuit

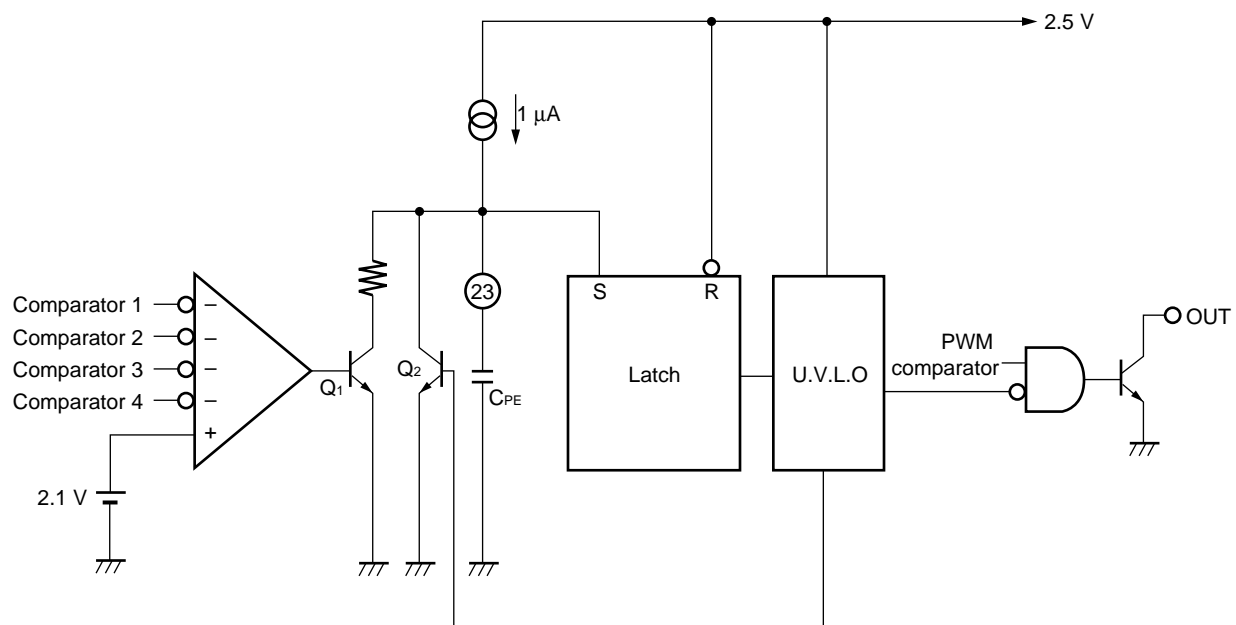

■ TREATMENT WHEN NOT USING SCP

When you do not use the timer/latch-actuated short-circuiting protection circuit, connect the SCP terminal (pin 23) to GND with the shortest distance possible. Also, connect the comparator's input terminal for each channel to the V_{CC1} terminal (pin 18).

Figure 6. Treatment When Not Using SCP

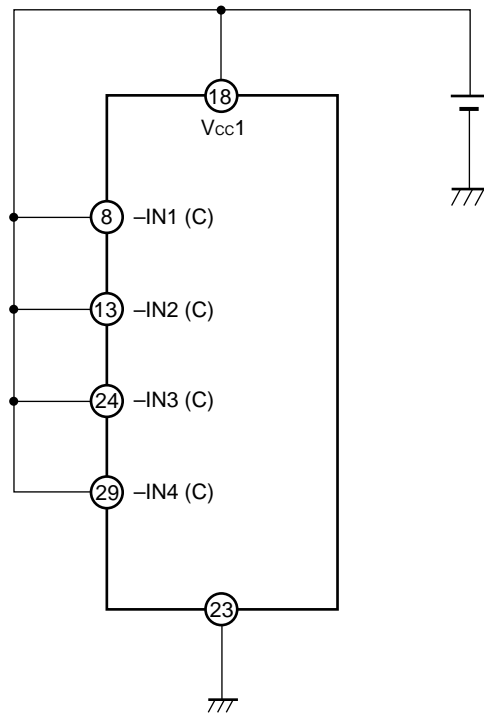

■ OSCILLATOR FREQUENCY SETTING

The oscillator frequency can be set by connecting a timing capacitor (C_T) to the CT terminal (pin 17) and a timing resistor (R_T) to the RT terminal (pin 16).

Oscillator frequency: f_{osc}

$$f_{osc} \text{ (kHz)} \doteq \frac{930000}{C_T(\mu\text{F}) \cdot R_T(\text{k}\Omega)}$$

■ METHOD OF SETTING THE TRIANGULAR-WAVE OSCILLATOR CIRCUIT

1. When Not Using Ceramic Resonator

Connect the OSC_{IN} terminal (pin 14) to GND and leave the OSC_{OUT} terminal (pin 15) open. This makes it possible to set the oscillation frequency with only C_T and R_T.

Figure 7. When Not Using Ceramic Resonator

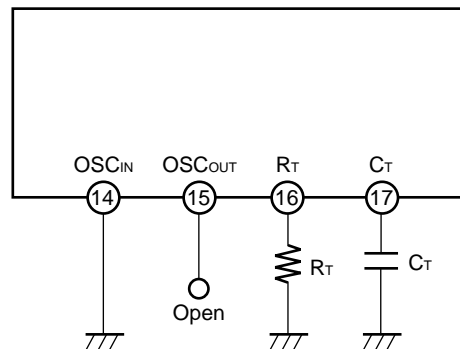

2. When Using Ceramic Resonator

By connecting a ceramic resonator between OSC_{IN} and OSC_{OUT} as shown below, you can set the oscillation frequency. In this case, too, C_T and R_T are required. Determine the values of C_T and R_T so that the oscillation frequency of this RC network is about 5-10% lower than that of the ceramic resonator.

Figure 8. When Using Ceramic Resonator

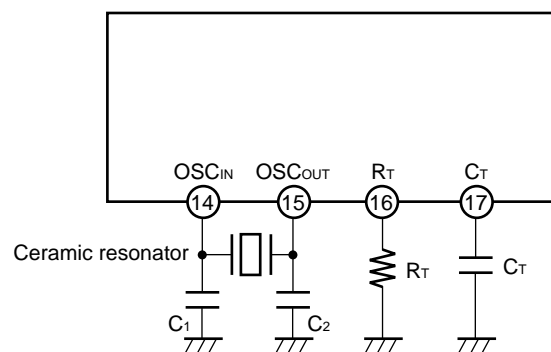

<Precautions>

When the oscillation rise time at power switch-on is compared between a ceramic and a crystal resonator, it is known that the crystal resonator is about 10 to 100 times slower to rise than the ceramic resonator. Therefore, when a crystal resonator is used, system operation as a switching regulator at power switch-on becomes unstable. To avoid this problem, it is recommended that you use a ceramic oscillator because it has a short rise time and, hence, ensures stable operation.

• Crystal Resonator Turn-on Characteristic

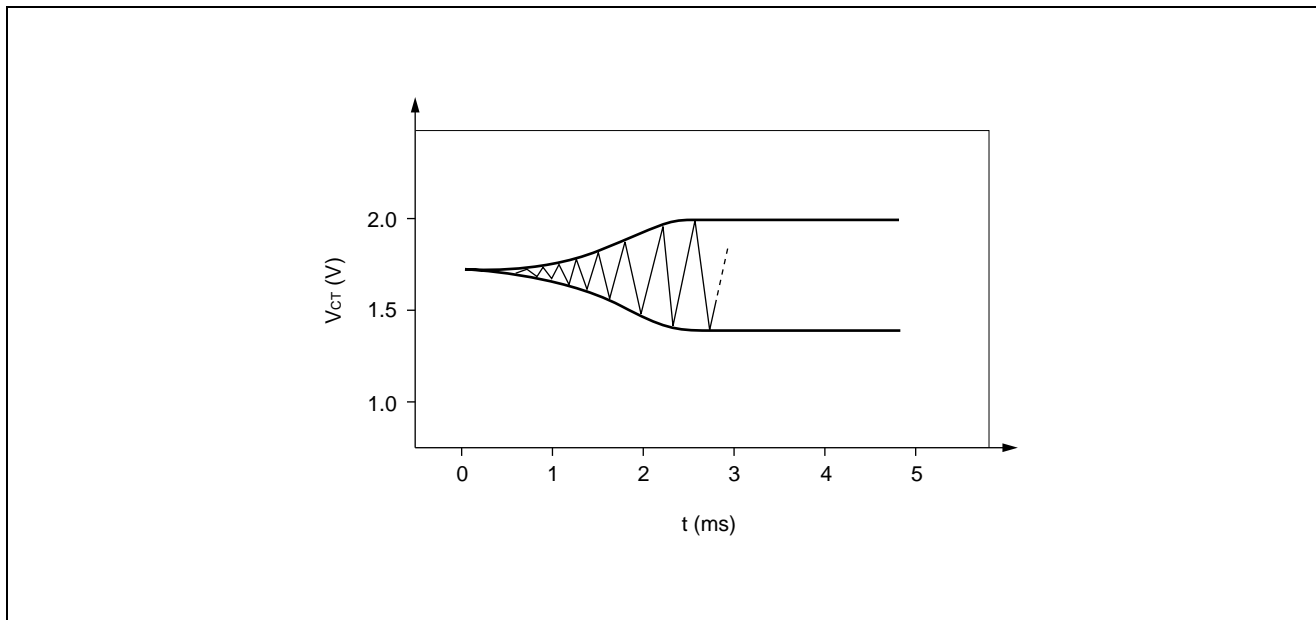

• Ceramic Resonator Turn-on Characteristic

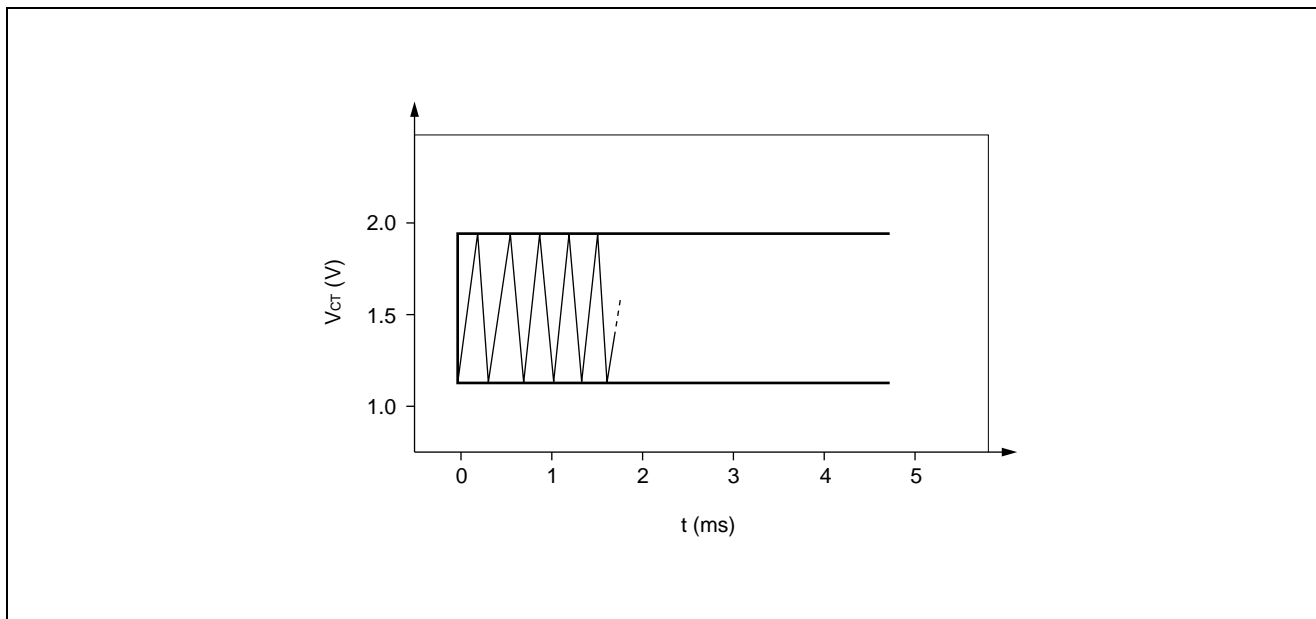

■ METHOD OF SETTING THE DEAD TIME

When the device is set for step-up inverted output based on the flyback method, the output transistor is fixed to a full-on state (ON-duty = 100 %) at power switch-on. To prevent this problem, you may determine the voltages on the DTC terminals (pins 4, 9, 28, and 33) from the V_{REF} voltage so you can easily set the output transistor's dead time (maximum ON-duty) independently for each channel as shown below.

(1) CH1 and CH2 Channels

When the voltage on the DTC terminals (pins 4 and 9) is higher than the triangular-wave output voltage from the oscillator, the output transistor turns off. The dead time calculation formula assuming that triangular-wave amplitude $\cong 0.6$ V and triangular-wave minimum voltage $\cong 1.3$ V is given below.

$$\text{Duty (OFF)} \cong \frac{V_{dt} - 1.3}{0.6} \times 100 [\%], \quad V_{dt} = \frac{R_2}{R_1 + R_2} \times V_{REF}$$

When you do not use these DTC terminals, connect them to GND.

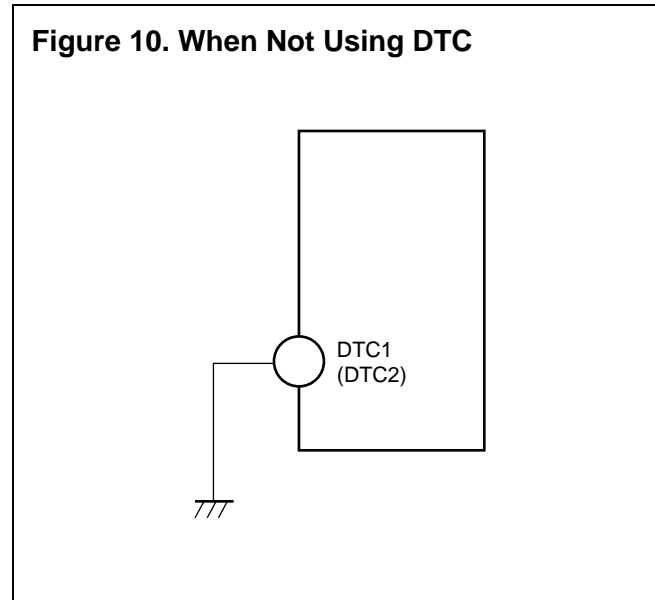
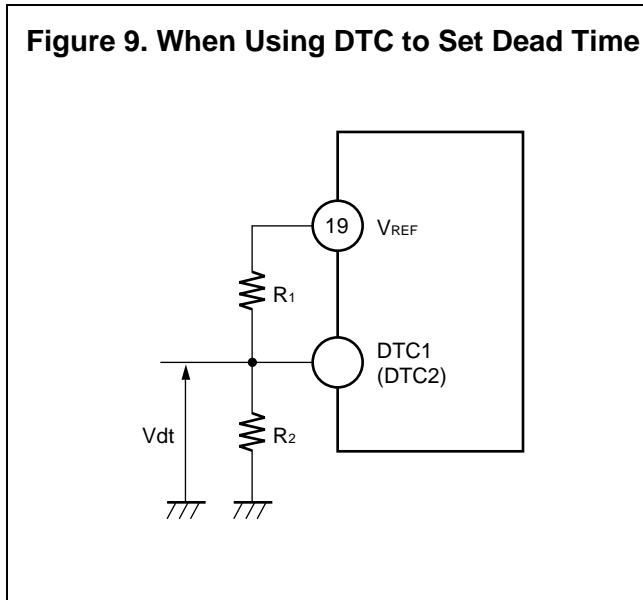

(2) CH3 and CH4 Channels

When the voltage on the DTC terminals (pins 28 and 33) is lower than the triangular-wave output voltage from the oscillator, the output transistor turns off. The dead time calculation formula assuming that triangular-wave amplitude $\cong 0.6$ V and triangular-wave maximum voltage $\cong 1.9$ V is given below.

$$\text{Duty (OFF)} \cong \frac{1.9 - V_{dt}}{0.6} \times 100 [\%], \quad V_{dt} = \frac{R_2}{R_1 + R_2} \times V_{REF}$$

When you do not use these DTC terminals, connect them to V_{REF} .

Figure 11. When Using DTC to Set Dead Time

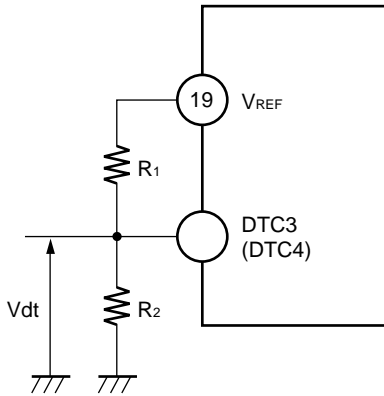
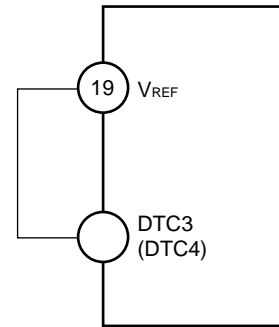

Figure 12. When Not Using DTC



<Precautions>

When you use a ceramic resonator, pay attention when setting the dead time because the triangular-wave amplitude is determined by the values of C_T and R_T .

■ METHODS OF SETTING THE SOFT START TIME

To prevent surge currents when the IC is turned on, you can set a soft start using the DTC terminal (pin 4, 9, 28 and 33).

When power is switched on, channels 1 and 2 begin discharging the capacitor (Cdt) connected the DTC1 (DTC2) terminal, channels 3 and 4 begin charging the capacitor (Cdt) connected the DTC3 (DTC4) terminal. The soft start process operates by comparing the soft start setting voltage, which is proportional to the DTC terminal voltage, with the triangular waveform, and varying the ON-duty of the OUT terminal (pin 46, 44, 40 and 39).

The soft start time until the ON duty reaches 50 % is determined by the following equation:

For figure 13

Soft start time (time until output ON duty = 50%)

$$t_s (s) = - C_{dt} (F) \times R_{dt} (\Omega) \times \ln \left(\frac{1.6}{2.5} \right) \quad \doteq \quad 0.446 \times C_{dt} (F) \times R_{dt} (\Omega)$$

For figure 14

Soft start time (time until output ON duty = 50%)

$$t_s (s) = - C_{dt} (F) \times R_{dt} (\Omega) \times \ln \left(1 - \frac{1.6}{2.5} \right) \quad \doteq \quad 1.022 \times C_{dt} (F) \times R_{dt} (\Omega)$$

Figure 13. Setting Soft Start for CH1 and CH2

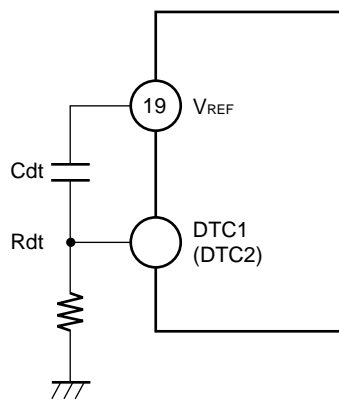
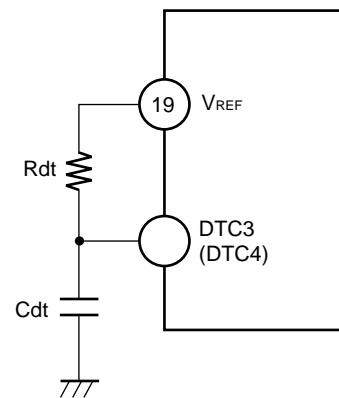

Figure 14. Setting Soft Start for CH3 and CH4



It is also possible to set soft start simultaneously with the dead time by configuring the DTC terminals as shown below.

For figure 15

Soft start time (time until output ON duty = 50%)

$$t_s (s) = - \frac{C_{dt} (F) \times R_1 (\Omega) \times R_2 (\Omega)}{R_1 (\Omega) + R_2 (\Omega)} \times \ln \left(0.64 - \frac{0.36 R_2 (\Omega)}{R_1 (\Omega)} \right)$$

For figure 16

Soft start time (time until output ON duty = 50%)

$$t_s (s) = - \frac{C_{dt} (F) \times R_1 (\Omega) \times R_2 (\Omega)}{R_1 (\Omega) + R_2 (\Omega)} \times \ln \left(1 - \frac{1.6 (R_1 (\Omega) + R_2 (\Omega))}{2.5 R_2 (\Omega)} \right)$$

Figure 15. Setting Dead Time and Soft Start for CH1 and CH2

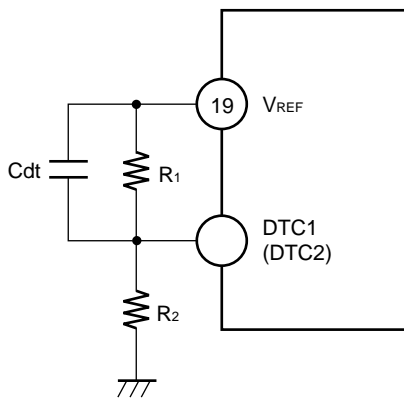
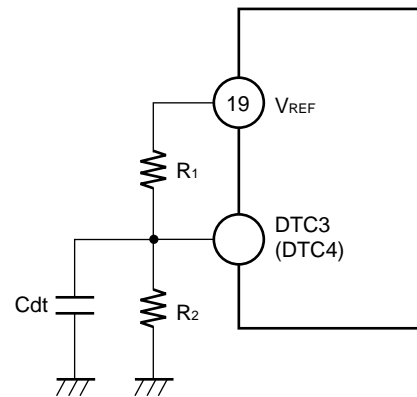

Figure 16. Setting Dead Time and Soft Start for CH3 and CH4



■ APPLICATION

1. Equivalent series resistor and stability of smoothing capacitor

The equivalent series resistor (ESR) of the smoothing capacitor in the DC/DC converter greatly affects the loop phase characteristic.

The stability of the system is improved so that the phase characteristic may advance the phase to the ideal capacitor by ESR in the high frequency region (see "Gain vs. Frequency" and "Phase vs. Frequency").

A smoothing capacitor with a low ESR reduces system stability. Use care when using low ESR electrolytic capacitors (OS-CON™) and tantalum capacitors.

Note: OS-CON is the trademark of Sanyo Electric Co., Ltd.

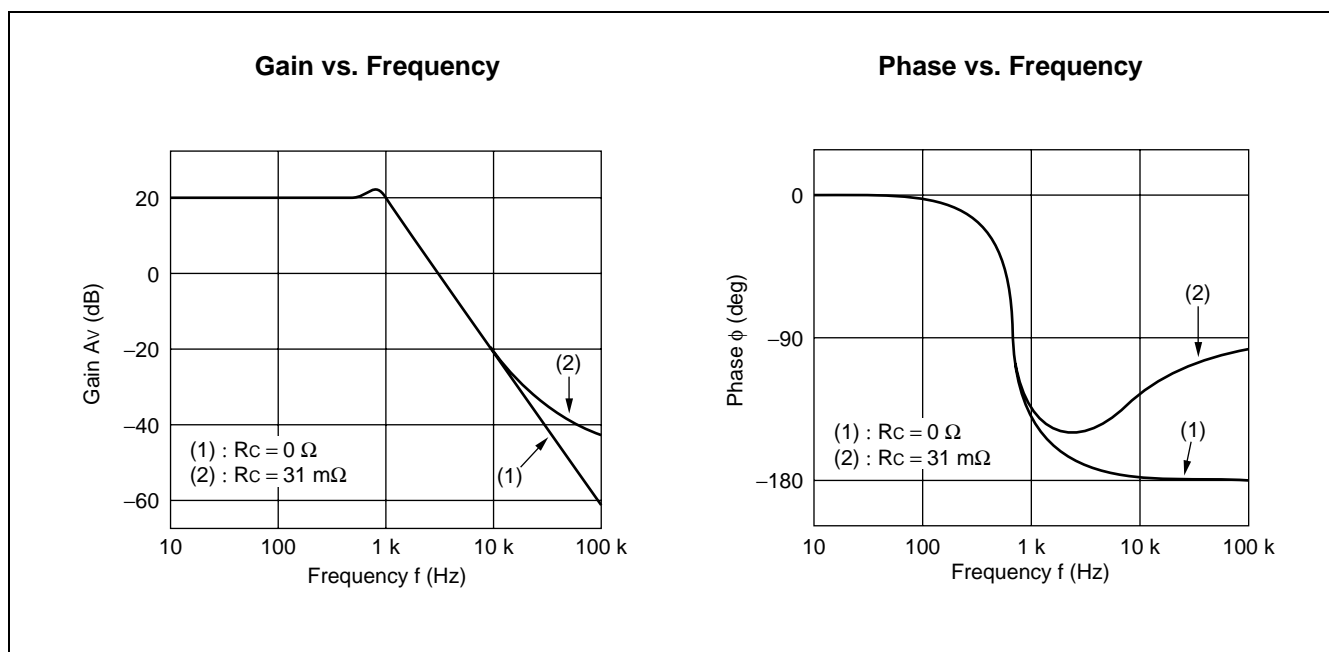
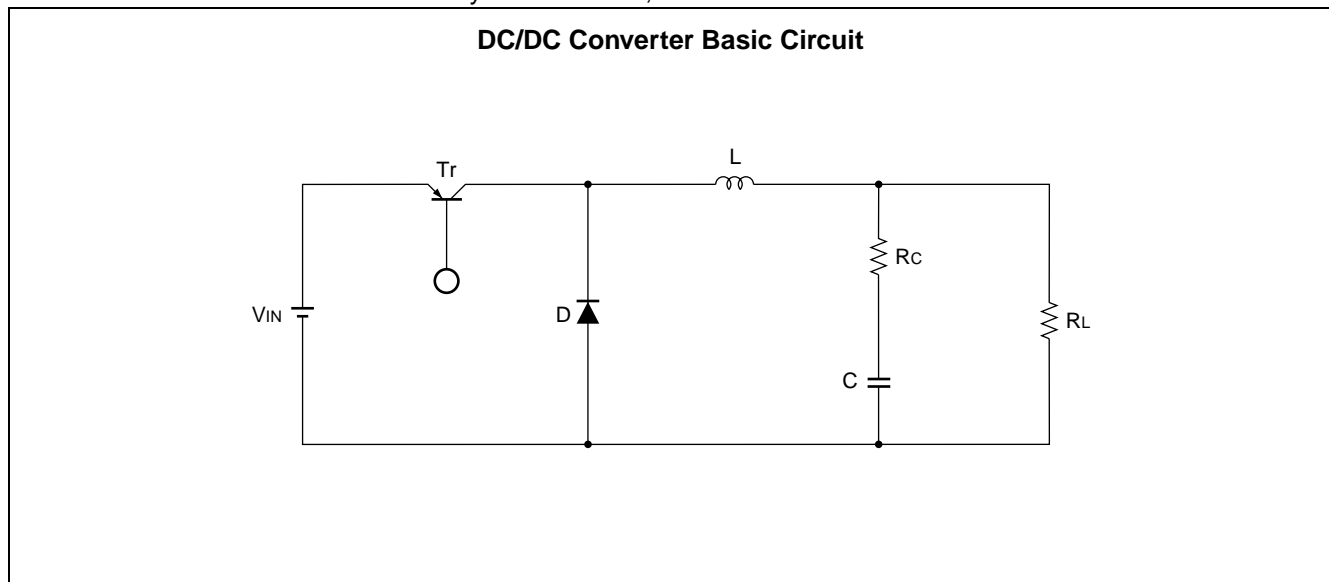

Reference data

If an aluminum electrolytic smoothing capacitor ($R_C \approx 1.0 \Omega$) is replaced with a low ESR electrolytic capacitor (OS-CON™ : $R_C \approx 0.2 \Omega$), the phase margin is reduced by half (see Fig. 37 and 38).

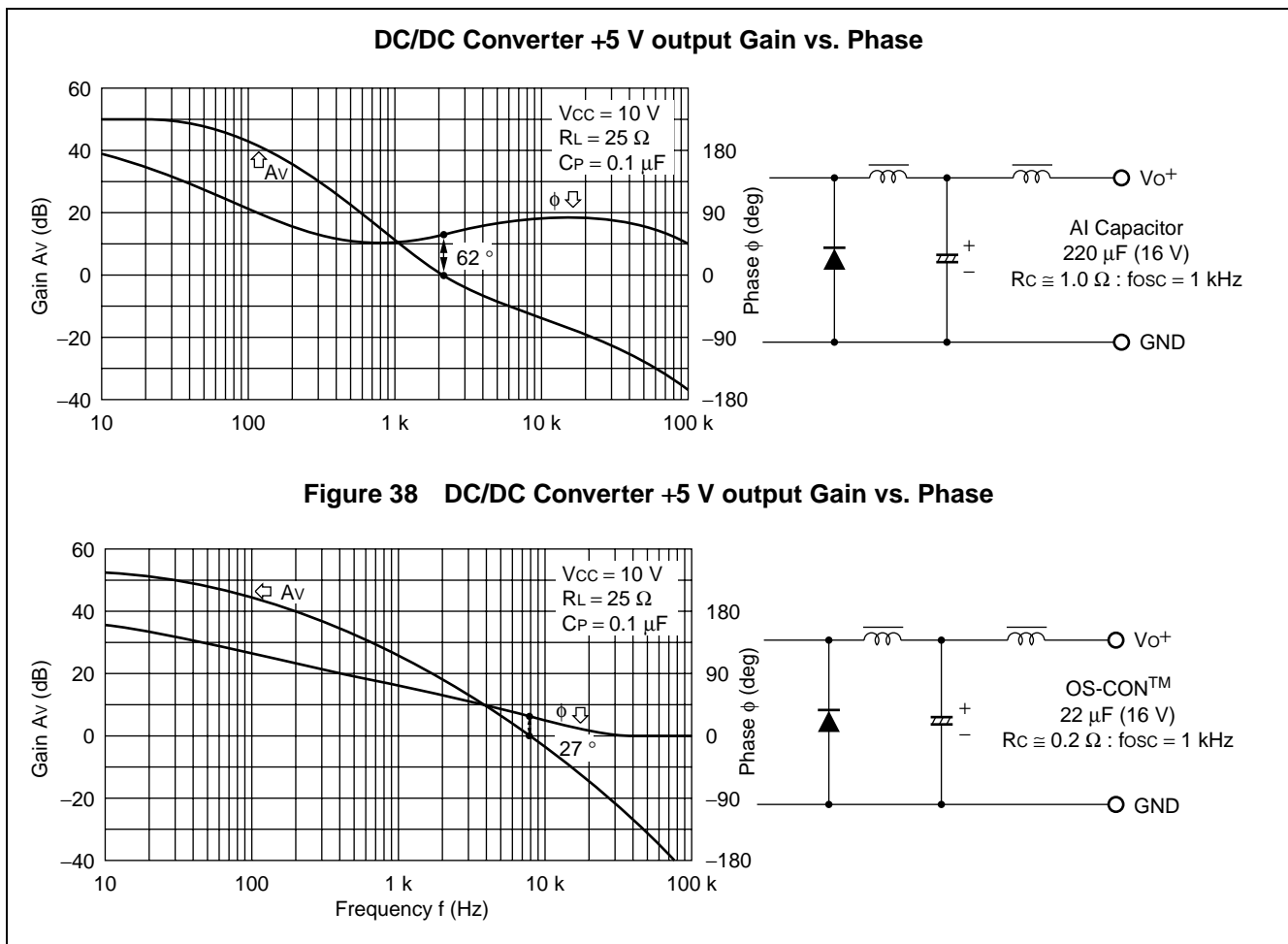
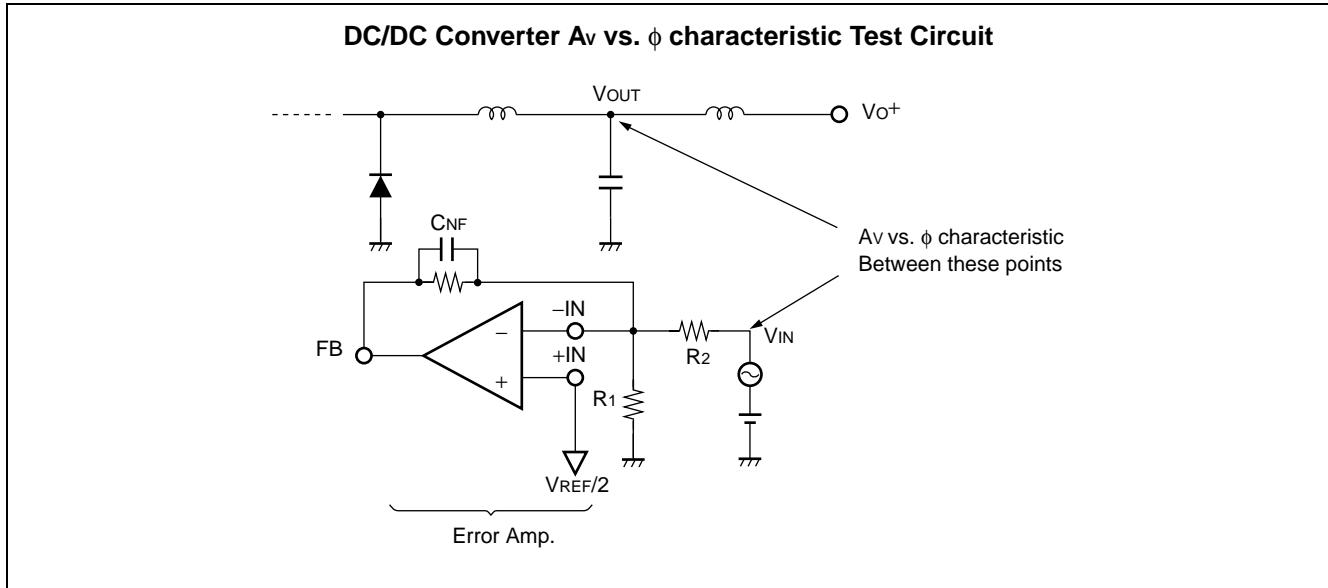

EXAMPLE OF APPLICATION CIRCUIT

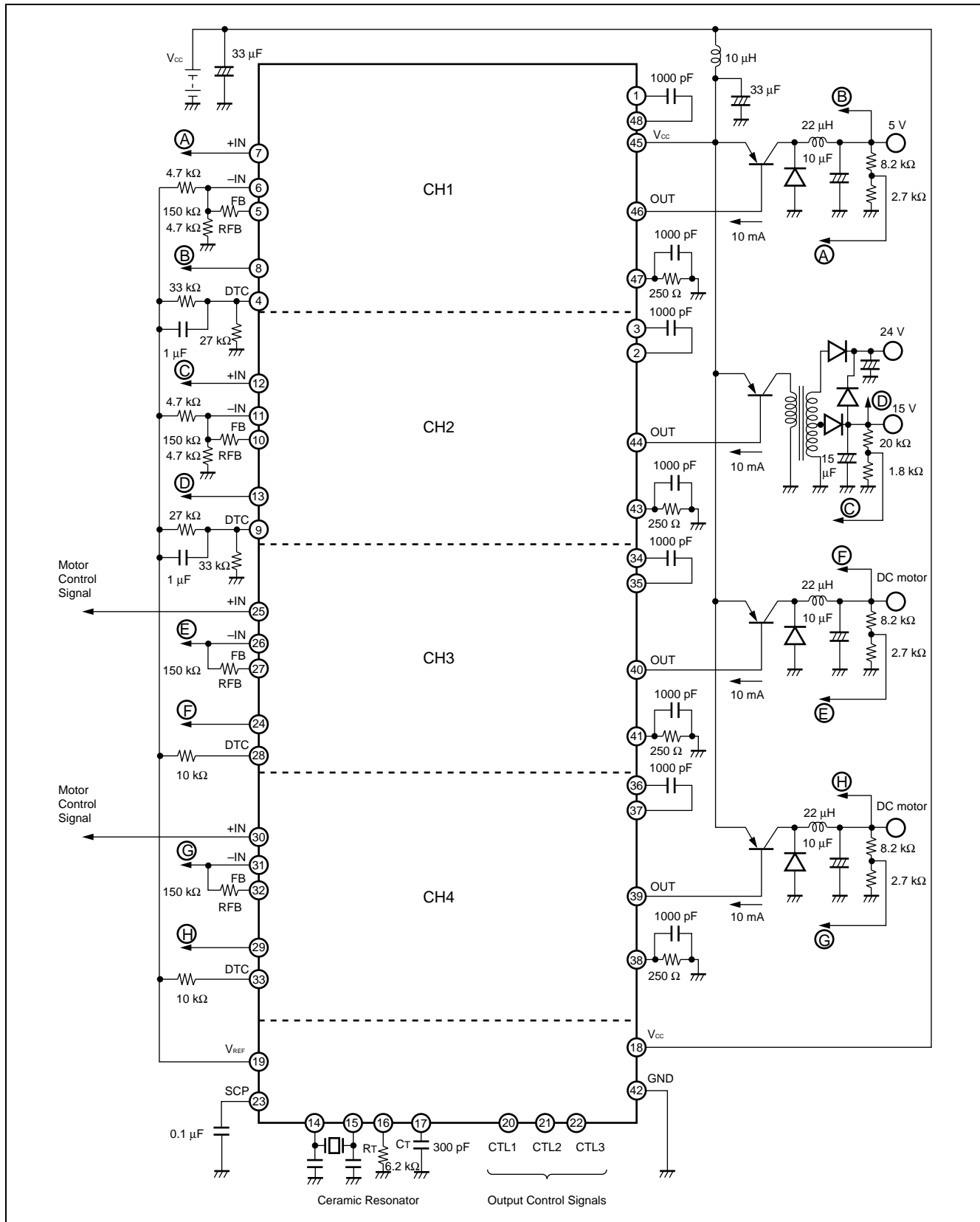

MB3785A

■ PRECAUTIONS ON USING THE DEVICE

1. Do not input voltages greater than the maximum rating.

Inputting voltages greater than the maximum rating may damage the device.

2. Always use the device under recommended operating conditions.

If a voltage greater than the maximum value is input to the device, its electrical characteristics may not be guaranteed. Similarly, inputting a voltage below the minimum value may cause device operation to become unstable.

3. For grounding the printed circuit board, use as wide ground lines as possible to prevent high-frequency noise.

Because the device uses high frequencies, it tends to generate high-frequency noise.

4. Take the following measures for protection against static charge:

- For containing semiconductor devices, use an antistatic or conductive container.
- When storing or transporting device-mounted circuit boards, use a conductive bag or container.
- Ground the workbenches, tools, and measuring equipment to earth.
- Make sure that operators wear wrist straps or other appropriate fittings grounded to earth via a resistance of 250 k Ω to 1 M Ω placed in series between the human body and earth.

■ ORDERING INFORMATION

Part number	Package	Remarks
MB3785APFV	48-pin plastic LQFP (FPT-48P-M05)	

■ PACKAGE DIMENSION

48-pin Plastic LQFP
(FPT-48P-M05)

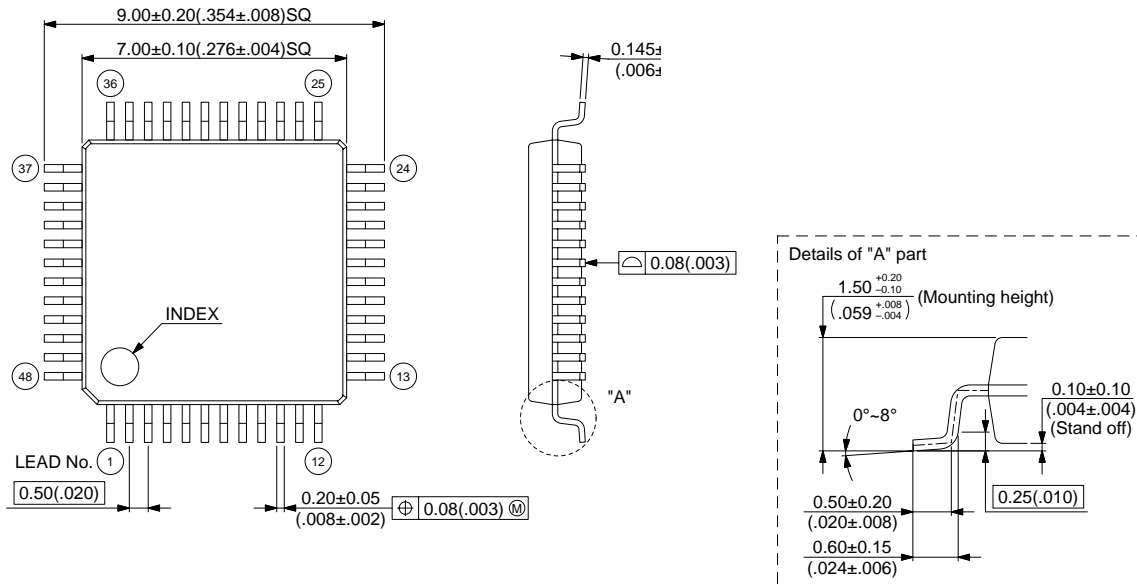

© 2000 FUJITSU LIMITED F48013S-c-4-8

Dimensions in: mm (inches)

FUJITSU LIMITED

All Rights Reserved.

The contents of this document are subject to change without notice. Customers are advised to consult with FUJITSU sales representatives before ordering.

The information and circuit diagrams in this document are presented as examples of semiconductor device applications, and are not intended to be incorporated in devices for actual use. Also, FUJITSU is unable to assume responsibility for infringement of any patent rights or other rights of third parties arising from the use of this information or circuit diagrams.

The products described in this document are designed, developed and manufactured as contemplated for general use, including without limitation, ordinary industrial use, general office use, personal use, and household use, but are not designed, developed and manufactured as contemplated (1) for use accompanying fatal risks or dangers that, unless extremely high safety is secured, could have a serious effect to the public, and could lead directly to death, personal injury, severe physical damage or other loss (i.e., nuclear reaction control in nuclear facility, aircraft flight control, air traffic control, mass transport control, medical life support system, missile launch control in weapon system), or (2) for use requiring extremely high reliability (i.e., submersible repeater and artificial satellite).

Please note that Fujitsu will not be liable against you and/or any third party for any claims or damages arising in connection with above-mentioned uses of the products.

Any semiconductor devices have an inherent chance of failure. You must protect against injury, damage or loss from such failures by incorporating safety design measures into your facility and equipment such as redundancy, fire protection, and prevention of over-current levels and other abnormal operating conditions.

If any products described in this document represent goods or technologies subject to certain restrictions on export under the Foreign Exchange and Foreign Trade Law of Japan, the prior authorization by Japanese government will be required for export of those products from Japan.

F0102
© FUJITSU LIMITED Printed in Japan