

5V/12V/15V or Adjustable, High-Efficiency, Low IQ, Step-Up DC-DC Controllers

General Description

The MAX770–MAX773 step-up switching controllers provide 90% efficiency over a 10mA to 1A load. A unique current-limited pulse-frequency-modulation (PFM) control scheme gives these devices the benefits of pulse-width-modulation (PWM) converters (high efficiency at heavy loads), while using less than 110µA of supply current (vs. 2mA to 10mA for PWM converters).

These ICs use tiny external components. Their high switching frequencies (up to 300kHz) allow surface-mount magnetics of 5mm height and 9mm diameter.

The MAX770/MAX771/MAX772 accept input voltages from 2V to 16.5V. Output voltages are preset at 5V, (MAX770), 12V (MAX771), and 15V (MAX772); they can also be adjusted using two resistors.

The MAX773 accepts inputs from 3V to 16.5V. For a wider input range, it features an internal shunt regulator that allows unlimited higher input voltages. The MAX773's output can be set to 5V, 12V, or 15V, or it can be adjusted with two resistors.

The MAX770–MAX773 drive external N-channel MOSFET switches, allowing them to power loads up to 15W. If less power is required, use the MAX756/MAX757 or MAX761/MAX762 step-up switching regulators with on-board MOSFETs.

Applications

- Palmtops/Handy-Terminals
- High-Efficiency DC-DC Converters
- Battery-Powered Applications
- Positive LCD-Bias Generators
- Portable Communicators
- Flash Memory Programmers

Typical Operating Circuit

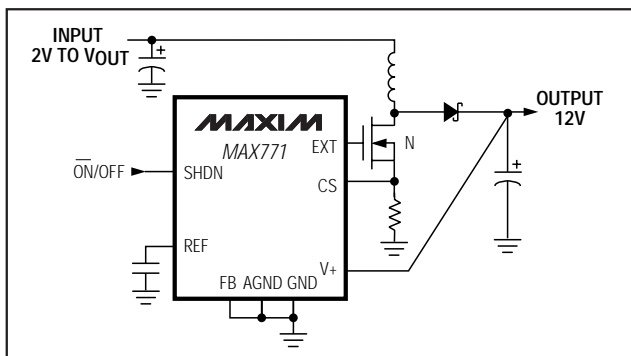

Features

- ◆ 90% Efficiency for 10mA to 1A Load Currents
- ◆ Up to 15W Output Power
- ◆ 110µA Max Supply Current
- ◆ 5µA Max Shutdown Current
- ◆ 2V to 16.5V Input Range (MAX770/MAX771/MAX772)
- ◆ Internal Shunt Regulator for High Input Voltages (MAX773)
- ◆ Preset or Adjustable Output Voltages
 - MAX770: 5V or Adjustable
 - MAX771: 12V or Adjustable
 - MAX772: 15V or Adjustable
 - MAX773: 5V, 12V, 15V, or Adjustable
- ◆ Current-Limited PFM Control Scheme
- ◆ 300kHz Switching Frequency

Ordering Information

PART	TEMP. RANGE	PIN-PACKAGE
MAX770CPA	0°C to +70°C	Plastic DIP
MAX770CSA	0°C to +70°C	8 SO
MAX770C/D	0°C to +70°C	Dice*
MAX770EPA	-40°C to +85°C	8 Plastic DIP
MAX770ESA	-40°C to +85°C	8 SO
MAX770MJA	-55°C to +125°C	8 CERDIP**

Ordering Information continued at end of data sheet.

*Contact factory for dice specifications.

**Contact factory for availability and processing to MIL-STD-883B.

Pin Configurations

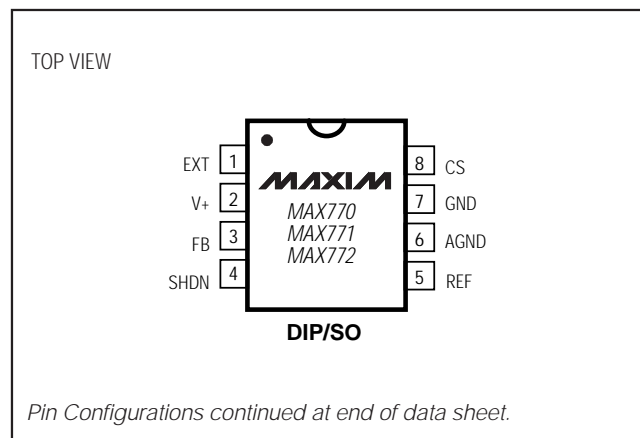

5V/12V/15V or Adjustable, High-Efficiency, Low IQ, Step-Up DC-DC Controllers

ABSOLUTE MAXIMUM RATINGS

Supply Voltages

V+ to GND	-0.3V to 17V
V+ to SGND	-0.3V to 7V
SGND	-0.3V to (V+ + 0.3V)
EXT, CS, REF, LBO, LBI, SHDN, FB	-0.3V to (V+ + 0.3V)
EXTH, EXTL	-0.3V to (V+ + 0.3V)
V5, V12, V15	-0.3V to 17V
GND to AGND	0.1V to -0.1V
ISGND	50mA
Continuous Power Dissipation (TA = +70°C)	
8-Pin Plastic DIP (derate 9.09mW/°C above +70°C)	727mW
8-Pin SO (derate 5.88mW/°C above +70°C)	471mW
8-Pin CERDIP (derate 8.00mW/°C above +70°C)	640mW

14-Pin Plastic DIP (derate 10.00mW/°C above +70°C)	800mW
14-Pin SO (derate 8.33mW/°C above +70°C)	667mW
14-Pin CERDIP (derate 9.09mW/°C above +70°C)	727mW
Operating Temperature Ranges	
MAX77_C__	0°C to +70°C
MAX77_E__	-40°C to +85°C
MAX77_MJ_	-55°C to +125°C
Junction Temperatures	
MAX77_C__/E__	+150°C
MAX77_MJ_	+175°C
Storage Temperature Range	-65°C to +160°C
Lead Temperature (soldering, 10sec)	+300°C

Stresses beyond those listed under "Absolute Maximum Ratings" may cause permanent damage to the device. These are stress ratings only, and functional operation of the device at these or any other conditions beyond those indicated in the operational sections of the specifications is not implied. Exposure to absolute maximum rating conditions for extended periods may affect device reliability.

ELECTRICAL CHARACTERISTICS

(V+ = 5V, ILOAD = 0mA, TA = TMIN to TMAX, unless otherwise noted. Typical values are at TA = +25°C.)

PARAMETER	SYMBOL	CONDITIONS	MIN	TYP	MAX	UNITS	
Input Voltage Range		MAX770-772 (internal feedback resistors)	2.0		16.5	V	
		MAX770-772C/E (external resistors)	3.0		16.5		
		MAX770-772MJA (external resistors)	3.1		16.5		
		MAX773C/E	3.0		16.5		
		MAX773MJD	3.1		16.5		
Minimum Start-Up Voltage		MAX770/MAX771/MAX772		1.8	2.0	V	
Supply Current		V+ = 16.5V, SHDN = 0V (normal operation)		85	110	μA	
Standby Current		V+ = 10.0V, SHDN ≥ 1.6V (shutdown)		2	5	μA	
		V+ = 16.5V, SHDN ≥ 1.6V (shutdown)		4			
Output Voltage (Note 1)		V+ = 2.0V to 5.0V, over full load range	4.80	5.0	5.20	V	
		V+ = 2.0V to 12.0V, over full load range	11.52	12.0	12.48		
		V+ = 2.0V to 15.0V, over full load range	14.40	15.0	15.60		
Output Voltage Line Regulation (Note 2)		Figure 2a, V+ = 2.7V to 4.5V, ILOAD = 700mA, VOUT = 5V		5		mV/V	
Output Voltage Load Regulation (Note 2)		Figure 2a, V+ = 3V, ILOAD = 30mA to 1A, VOUT = 5V		20		mV/A	
Maximum Switch On-Time	tON(max)		12	16	20	μs	
Minimum Switch Off-Time	tOFF(min)		1.8	2.3	2.8	μs	
Efficiency		V+ = 4V, ILOAD = 500mA, VOUT = 5V		87		%	
Reference Voltage	VREF	IREF = 0μA	MAX77_C	1.4700	1.5	1.5300	V
			MAX77_E	1.4625	1.5	1.5375	
			MAX77_M	1.4550	1.5	1.5450	

5V/12V/15V or Adjustable, High-Efficiency, Low IQ, Step-Up DC-DC Controllers

MAX770-MAX773

ELECTRICAL CHARACTERISTICS (continued)

(V+ = 5V, I_{LOAD} = 0mA, T_A = T_{MIN} to T_{MAX}, unless otherwise noted. Typical values are at T_A = +25°C.)

PARAMETERS	SYMBOL	CONDITIONS	MIN	TYP	MAX	UNITS	
REF Load Regulation		0μA ≤ I _{REF} ≤ 100μA	MAX77_C/E	4	10	mV	
			MAX77_M	4	15		
REF Line Regulation		3V ≤ V+ ≤ 16.5V		40	100	μV/V	
FB Trip-Point Voltage	V _{FB}	MAX77_C	1.4700	1.50	1.5300	V	
		MAX77_E	1.4625	1.50	1.5375		
		MAX77_M	1.4550	1.50	1.5450		
FB Input Current	I _{FB}	MAX77_C			±20	nA	
		MAX77_E			±40		
		MAX77_M			±60		
SHDN Input High Voltage	V _{IH}	V+ = 2.0V to 16.5V	1.6			V	
SHDN Input Low Voltage	V _{IL}	MAX77_C/E, V+ = 2.0V to 16.5V			0.4	V	
		MAX77_M, V+ = 2.0V to 16.5V			0.2		
SHDN Input Current		V+ = 16.5V, SHDN = 0V or V+			±1	μA	
LBI Input Current		MAX773, V+ = 16.5V, LBI = 1.5V			±20	nA	
LBI Hysteresis		MAX773		20		mV	
LBI Delay		5mV overdrive		2.5		μs	
LBI Threshold Voltage		MAX773, LBI falling	MAX77_C	1.4700	1.50	1.5300	V
			MAX77_E	1.4625	1.50	1.5375	
			MAX77_M	1.4550	1.50	1.5450	
LBO Leakage Current		MAX773, V+ = 16.5V, V _{LBO} = 16.5V		0.01	1.00	μA	
LBO Output Voltage Low	V _{OL}	MAX773, V+ = 5V, LBO sinking 1mA		0.1	0.4	V	
Current-Limit Trip Level	V _{CS}	V+ = 5V to 16.5V	170	200	230	mV	
CS Input Current				0.01	±1	μA	
EXT Rise Time		V+ = 5V, 1nF from EXT to ground (Note 3)		55		ns	
EXT Fall Time		V+ = 5V, 1nF from EXT to ground (Note 3)		55		ns	
Supply Voltage in Shunt Mode	V _{SHUNT}	MAX773, I _{SHUNT} = 1mA to 20mA, SGND = 0V, C _{SHUNT} = 0.1μF	5.5		6.3	V	

Note 1: Output voltage guaranteed using preset voltages. See Figures 7a–7d for output current capability versus input voltage.

Note 2: Output voltage line and load regulation depend on external circuit components.

Note 3: For the MAX773, EXT is EXTH and EXTL shorted together.

5V/12V/15V or Adjustable, High-Efficiency, Low IQ, Step-Up DC-DC Controllers

Typical Operating Characteristics

($T_A = +25^\circ\text{C}$, unless otherwise noted.)

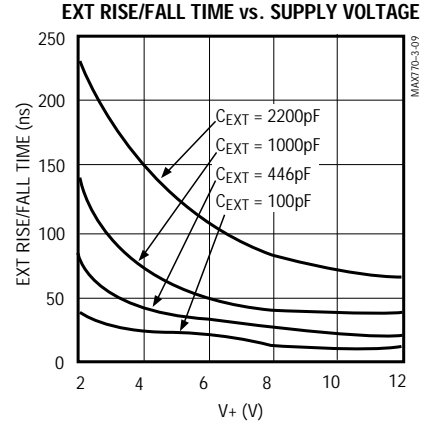
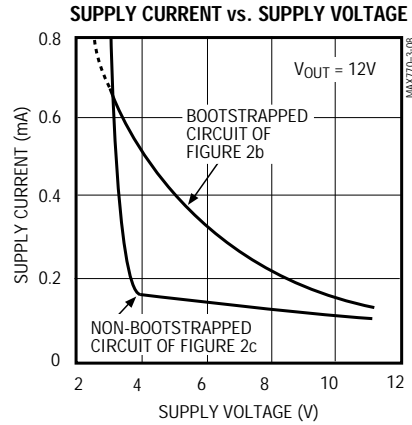
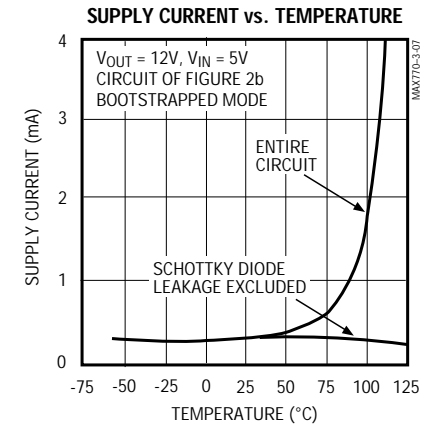
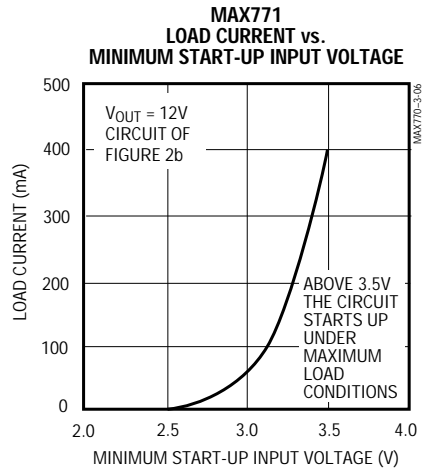
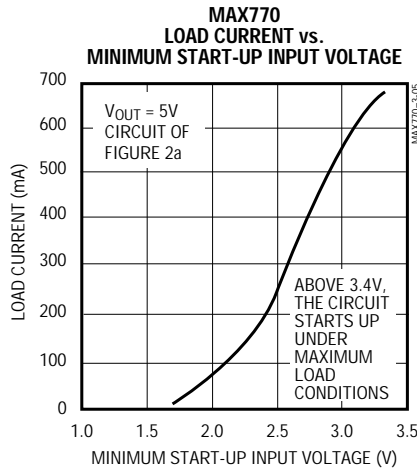
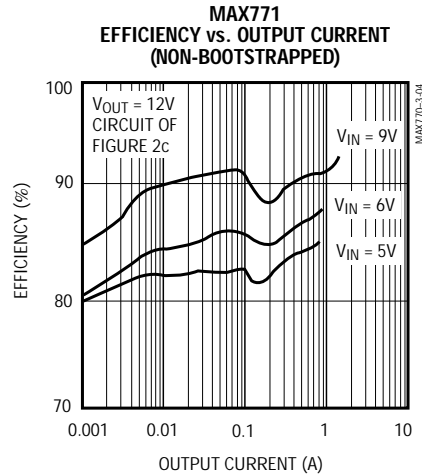
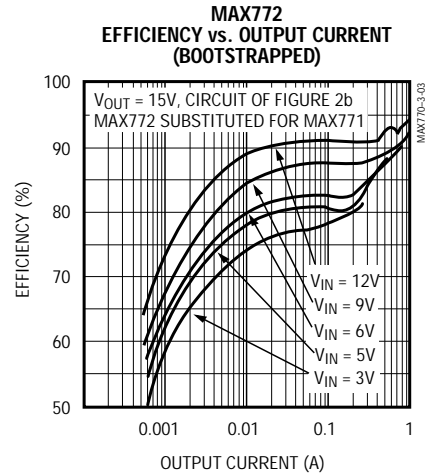
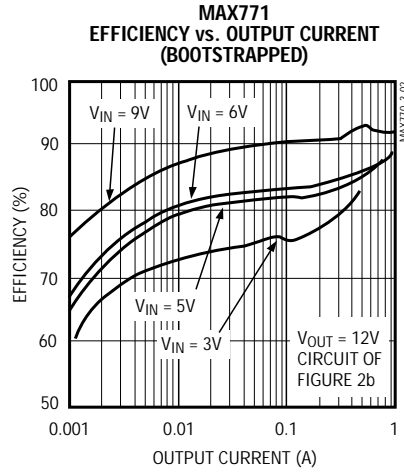
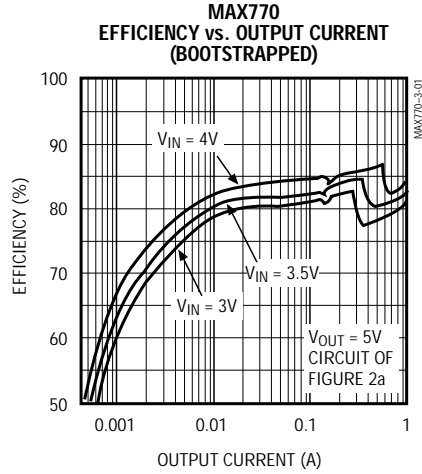

5V/12V/15V or Adjustable, High-Efficiency, Low IQ, Step-Up DC-DC Controllers

MAX770-MAX773

Typical Operating Characteristics (continued)
 (T_A = +25°C, unless otherwise noted.)

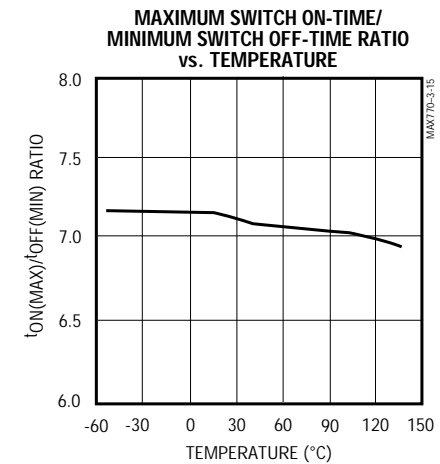
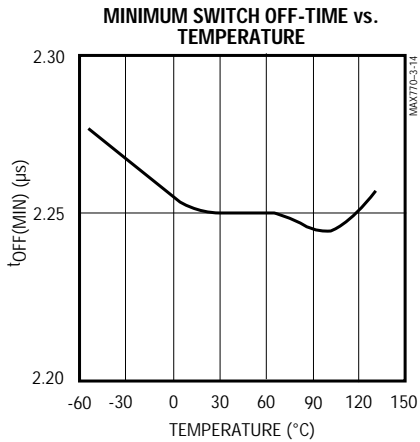
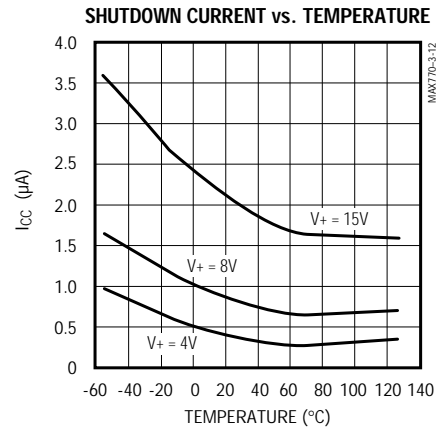
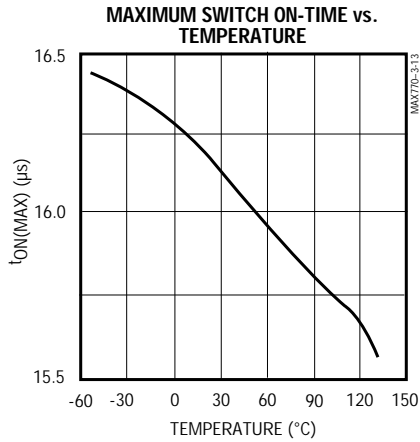
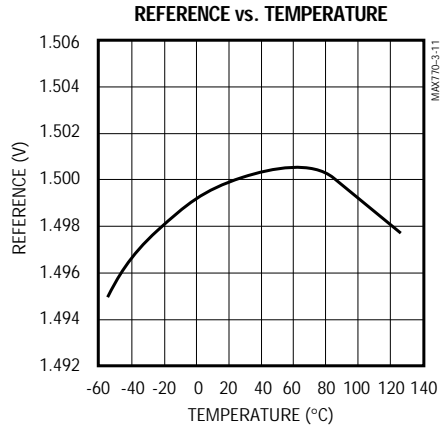
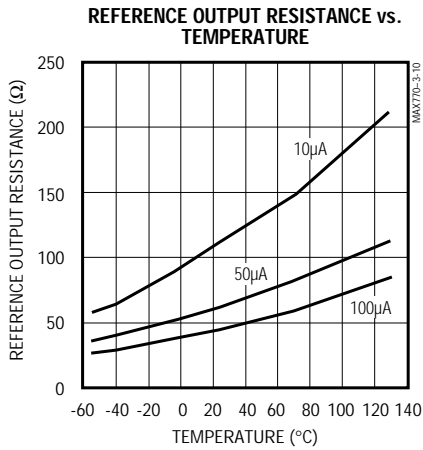

5V/12V/15V or Adjustable, High-Efficiency, Low IQ, Step-Up DC-DC Controllers

Typical Operating Characteristics (continued)

(Circuit of Figure 2a, $T_A = +25^\circ\text{C}$, unless otherwise noted.)

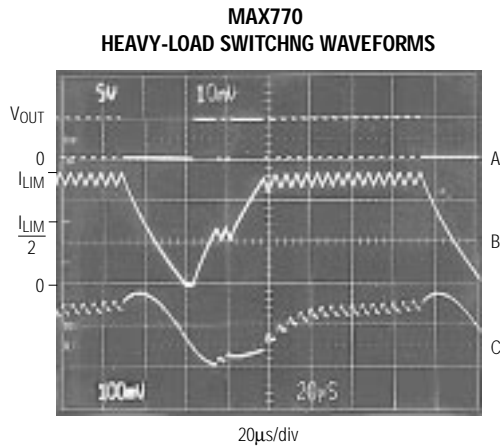

$V_{IN} = 2.9\text{V}$, $I_{OUT} = 0.9\text{A}$
 A: EXT VOLTAGE, 5V/div
 B: INDUCTOR CURRENT 1A/div
 C: V_{OUT} RIPPLE 100mV/div, AC-COUPLED

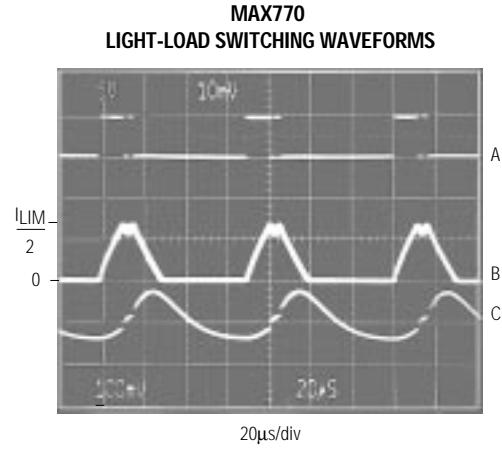

$V_+ = 3\text{V}$, $I_{OUT} = 165\text{mA}$
 A: EXT VOLTAGE, 5V/div
 B: INDUCTOR CURRENT, 1A/div
 C: V_{OUT} RIPPLE 100mV/div, AC-COUPLED

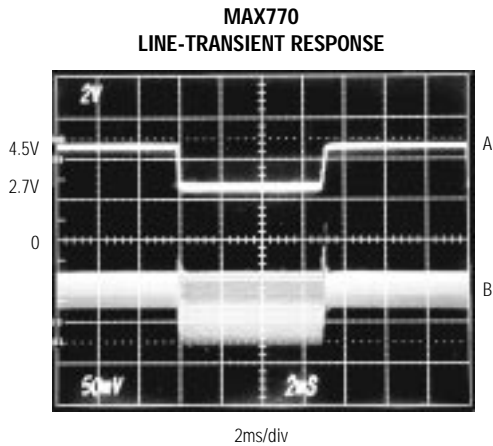

$I_{OUT} = 0.7\text{A}$
 A: V_{IN} , 2.7V TO 4.5V, 2V/div
 B: V_{OUT} RIPPLE, 100mV/div, AC-COUPLED

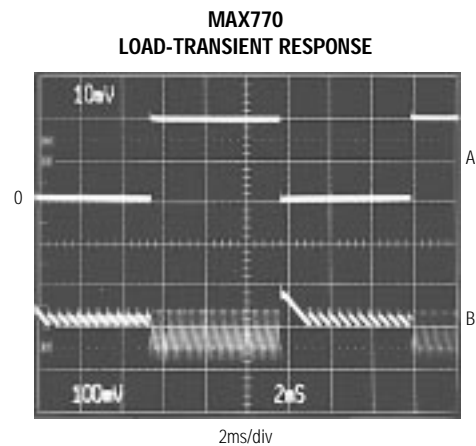

$V_{IN} = 3\text{V}$
 A: LOAD CURRENT 0.5A/div (0A TO 1A)
 B: V_{OUT} RIPPLE, 100mV/div, AC-COUPLED

5V/12V/15V or Adjustable, High-Efficiency, Low IQ, Step-Up DC-DC Controllers

Typical Operating Characteristics (continued)

(Circuit of Figure 2a, $T_A = +25^\circ\text{C}$, unless otherwise noted.)

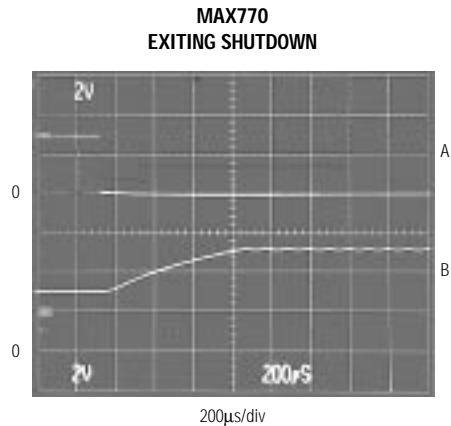

$V_{IN} = 3\text{V}$, $I_{OUT} = 0.5\text{A}$
A: SHDN, 2V/div
B: V_{OUT} , 2V/div

Pin Description

PIN		NAME	FUNCTION
MAX770 MAX771 MAX772	MAX773		
1	—	EXT	Gate drive for external N-channel power transistor
2	3	V+	Power-supply input. Also acts as a voltage-sense point when in bootstrapped mode for the MAX770/MAX771/MAX772, or as a shunt regulator when SGND is connected to ground for the MAX773. Bypass to SGND with 0.1µF when using the shunt regulator.
3	6	FB	Feedback input for adjustable-output operation. Connect to ground for fixed-output operation. Use a resistor divider network to adjust the output voltage. See <i>Setting the Output Voltage</i> section.
4	7	SHDN	Active-high TTL/CMOS logic-level shutdown input. In shutdown mode, V_{OUT} is a diode drop below V+ (due to the DC path from V+ to the output) and the supply current drops to 5µA maximum. Connect to ground for normal operation.
5	8	REF	1.5V reference output that can source 100µA for external loads. Bypass to GND with 0.1µF. The reference is disabled in shutdown.
6	—	AGND	Analog ground
7	9	GND	High-current ground return for the output driver
8	11	CS	Positive input to the current-sense amplifier. Connect the current-sense resistor between CS and GND.
—	1	V12	Input sense point for 12V-output operation. Connect V_{OUT} to V12 for 12V-output operation. Leave unconnected for adjustable-output operation.
—	2	V5	Input sense point for 5V-output operation. Connect V_{OUT} to V5 for 5V-output operation. Leave unconnected for adjustable-output operation.
—	4	LBO	Low-battery output is an open-drain output that goes low when LBI is less than 1.5V. Connect to V+ through a pull-up resistor. Leave floating if not used. LBO is high impedance in shutdown mode.
—	5	LBI	Input to the internal low-battery comparator. Tie to GND or V+ if not used.
—	10	SGND	Shunt regulator ground. Leave unconnected if the shunt regulator is not used.

5V/12V/15V or Adjustable, High-Efficiency, Low IQ, Step-Up DC-DC Controllers

Pin Description (continued)

PIN		NAME	FUNCTION
MAX770 MAX771 MAX772	MAX773		
—	12	EXTL	Low-level gate/base drive for external power transistor. Connect to the gate of an external N-channel MOSFET or to the base of an external NPN transistor.
—	13	EXTH	High-level gate/base drive for external power transistor. Connect to EXTL when using an external N-channel MOSFET. When using an external NPN transistor, connect a resistor R_{BASE} from EXTH to the base of the NPN to set the maximum base-drive current.
—	14	V15	Input sense point for 15V-output operation. Connect V_{OUT} to V15 for 15V-output operation. Leave unconnected for adjustable-output operation

Detailed Description

The MAX770-MAX773 are BiCMOS, step-up, switch-mode power-supply controllers that provide preset 5V, 12V, and 15V output voltages, in addition to adjustable-output operation. Their unique control scheme combines the advantages of pulse-frequency modulation (low supply current) and pulse-width modulation (high efficiency with heavy loads), providing high efficiency over a wide output current range, as well as increased output current capability over previous PFM devices. In addition, the external sense resistor and power transistor allow the user to tailor the output current capability for each application. Figure 1 shows the MAX770-MAX773 block diagram.

The MAX770-MAX773 offer three main improvements over prior pulse-skipping control solutions: 1) the converters operate with tiny (5mm height and less than 9mm diameter) surface-mount inductors due to their 300kHz switching frequency; 2) the current-limited PFM control scheme allows 87% efficiencies over a wide range of load currents; and 3) the maximum supply current is only 110 μ A.

The MAX773 can be configured to operate from an internal 6V shunt regulator, allowing very high input/output voltages. Its output can be configured for an adjustable voltage or for one of three fixed voltages (5V, 12V, or 15V), and it has a power-fail comparator for low-battery detection.

All devices have shutdown capability, reducing the supply current to 5 μ A max.

Bootstrapped/Non-Bootstrapped Modes

Figures 2 and 3 show standard application circuits for bootstrapped and non-bootstrapped modes. In bootstrapped mode, the IC is powered from the output (V_{OUT} , which is connected to $V+$) and the input voltage

range is 2V to V_{OUT} . The voltage applied to the gate of the external power transistor is switched from V_{OUT} to ground, providing more switch gate drive and thus reducing the transistor's on resistance.

In non-bootstrapped mode, the IC is powered from the input voltage ($V+$) and operates with minimum supply current. In this mode, FB is the output voltage sense point. Since the voltage swing applied to the gate of the external power transistor is reduced (the gate swings from $V+$ to ground), the power transistor's on resistance increases at low input voltages. However, the supply current is also reduced because $V+$ is at a lower voltage, and because less energy is consumed while charging and discharging the external MOSFET's gate capacitance. The minimum input voltage for the MAX770-MAX773 is 3V when using external feedback resistors. With supply voltages below 5V, bootstrapped mode is recommended.

Note: When using the MAX770/MAX771/MAX772 in non-bootstrapped mode, there is no preset output operation because $V+$ is also the output voltage sense point for fixed-output operation. External resistors must be used to set the output voltage. Use 1% external feedback resistors when operating in adjustable-output mode (Figures 2c, 2d, 3b, 3d, 3e) to achieve an overall output voltage accuracy of $\pm 5\%$. The MAX773 can be operated in non-bootstrapped mode without using external feedback resistors because $V+$ does not act as the output voltage sense point with preset-output operation. To achieve highest efficiency, operate in bootstrapped mode whenever possible.

MAX773 Shunt-Regulator Operation

The MAX773 has an internal 6V shunt regulator that allows the device to step up from very high input voltages (Figure 4).

5V/12V/15V or Adjustable, High-Efficiency, Low IQ, Step-Up DC-DC Controllers

MAX770-MAX773

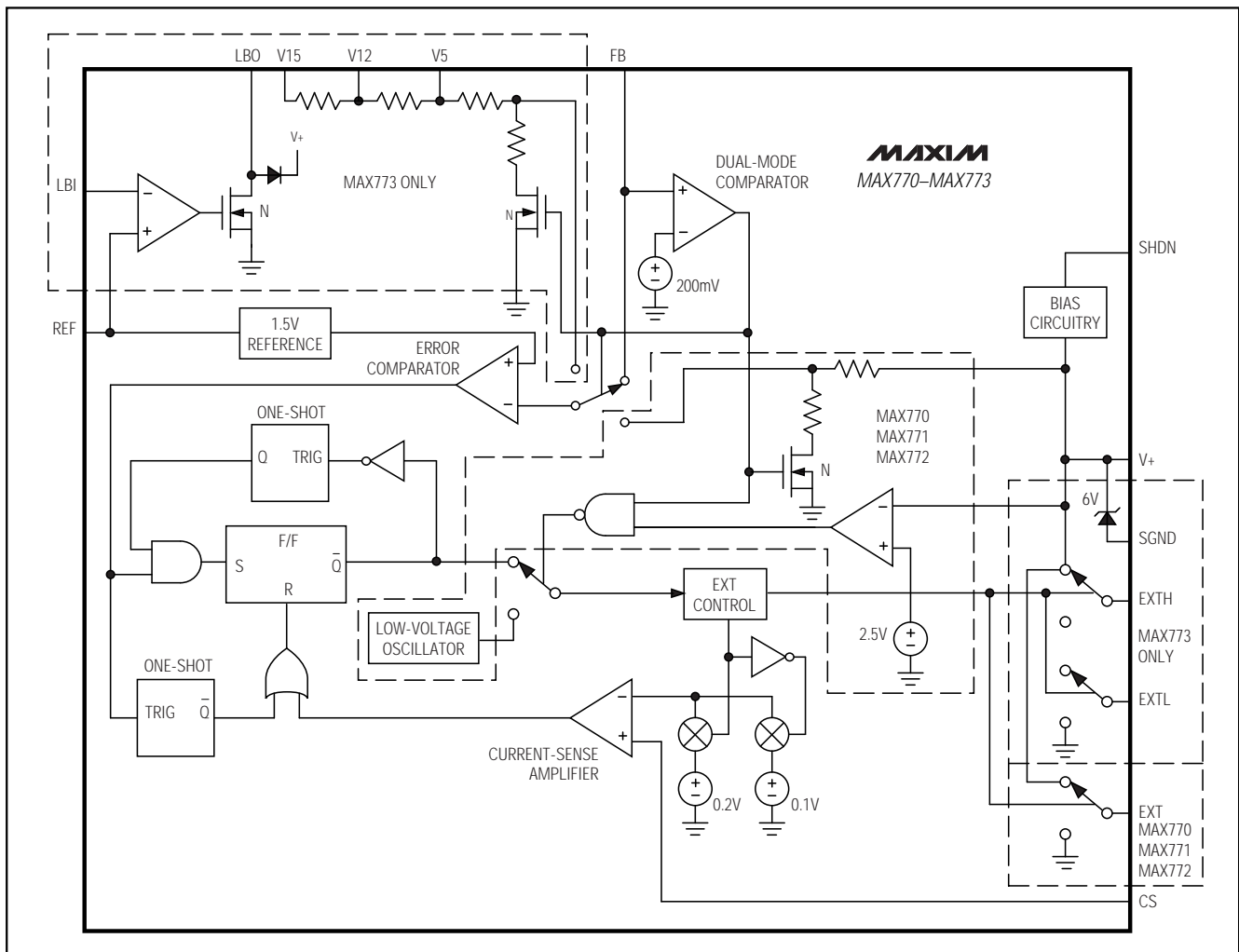

Figure 1. Block Diagram

Floating the shunt-regulator ground (SGND) disables the shunt regulator. To enable it, connect SGND to GND. The shunt regulator requires 1mA minimum current for proper operation; the maximum current must not exceed 20mA. The MAX773 operates in non-bootstrapped mode when the shunt regulator is used, and EXT swings between the 6V shunt-regulator voltage and GND.

When using the shunt regulator, use an N-channel power FET instead of an NPN power transistor as the power switch. Otherwise, excessive base drive will collapse the shunt regulator.

External Power-Transistor Control Circuitry

PFM Control Scheme

The MAX770-MAX773 use a proprietary current-limited PFM control scheme to provide high efficiency over a wide range of load currents. This control scheme combines the ultra-low supply current of PFM converters (or pulse skippers) with the high full-load efficiency of PWM converters.

Unlike traditional PFM converters, the MAX770-MAX773 use a sense resistor to control the peak inductor current. They also operate with high switching

5V/12V/15V or Adjustable, High-Efficiency, Low IQ, Step-Up DC-DC Controllers

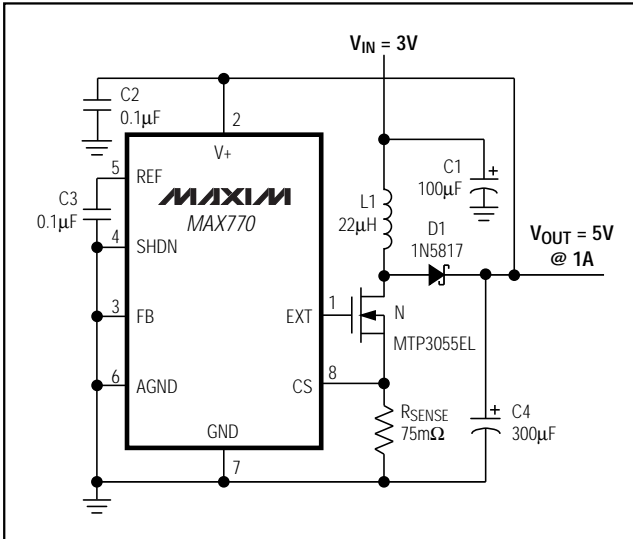

Figure 2a. 5V Preset Output, Bootstrapped

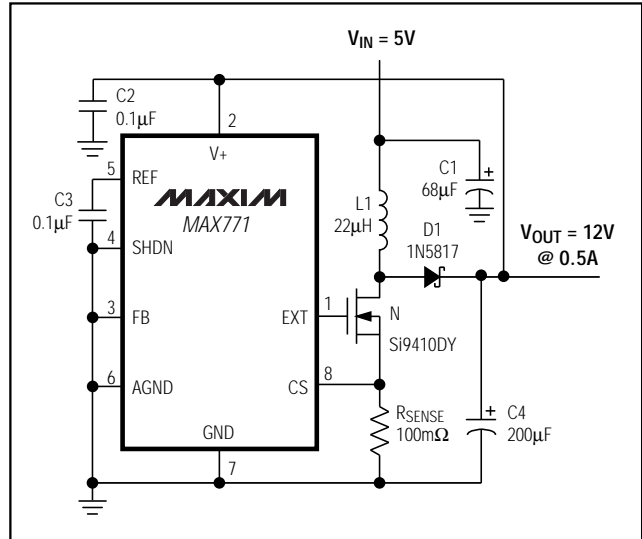

Figure 2b. 12V Preset Output, Bootstrapped

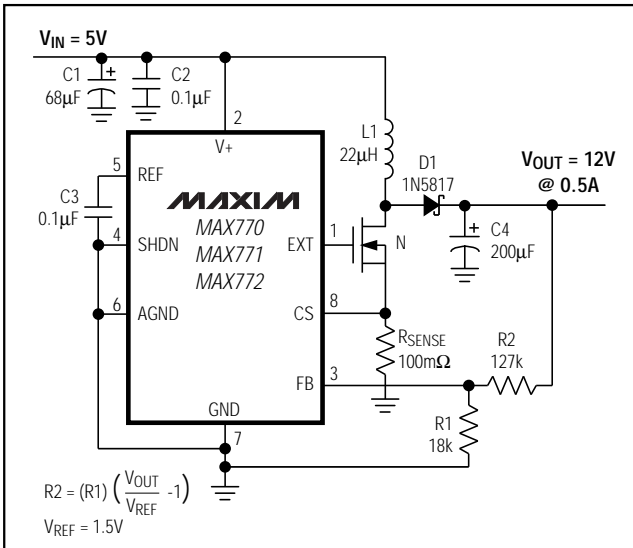

Figure 2c. 12V Output, Non-Bootstrapped

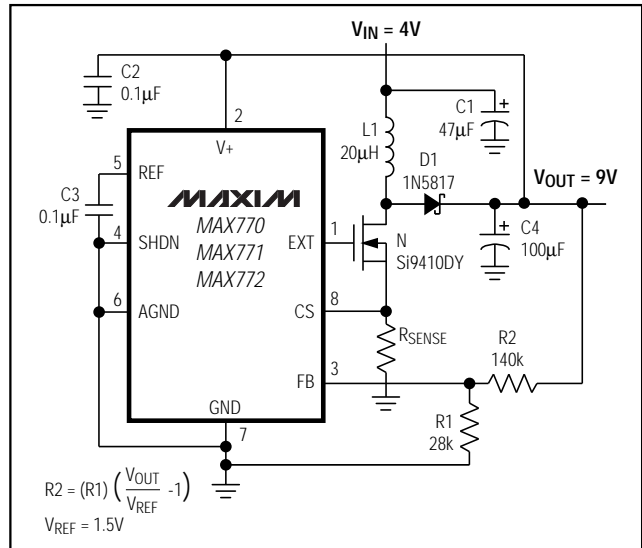

Figure 2d. 9V Output, Bootstrapped

frequencies (up to 300kHz), allowing the use of tiny external components.

As with traditional PFM converters, the power transistor is not turned on until the voltage comparator senses that the output is out of regulation. However, unlike traditional PFM converters, the MAX770-MAX773 switch using the combination of a peak current limit and a pair of one-shots that set the maximum on-time (16µs) and

minimum off-time (2.3µs); there is no oscillator. Once off, the minimum off-time one-shot holds the switch off for 2.3µs. After this minimum time, the switch either 1) stays off if the output is in regulation, or 2) turns on again if the output is out of regulation.

The control circuitry allows the ICs to operate in continuous-conduction mode (CCM) while maintaining high efficiency with heavy loads. When the power switch is

5V/12V/15V or Adjustable, High-Efficiency, Low IQ, Step-Up DC-DC Controllers

MAX770-MAX773

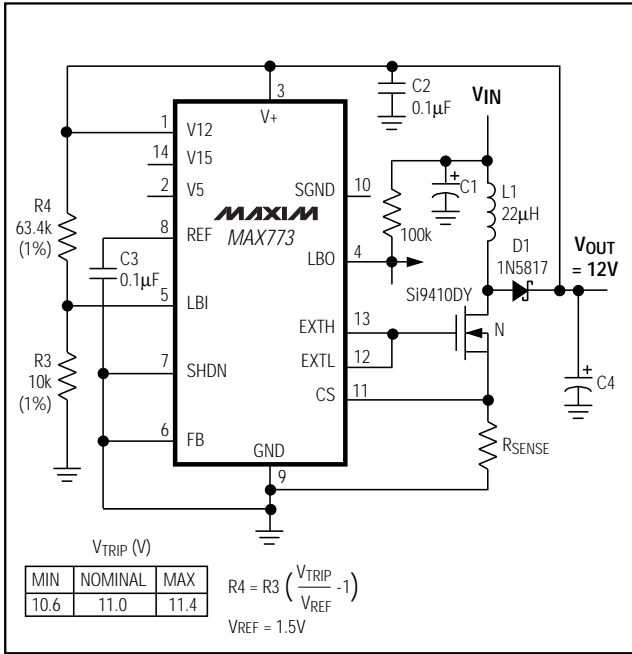

Figure 3a. 12V Preset Output, Bootstrapped, N-Channel Power MOSFET

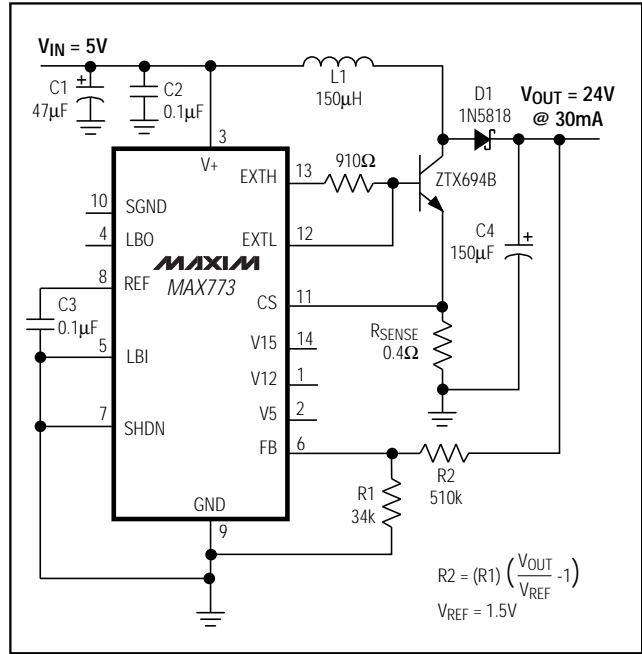

Figure 3b. 24V Output, Non-Bootstrapped, NPN Power Transistor

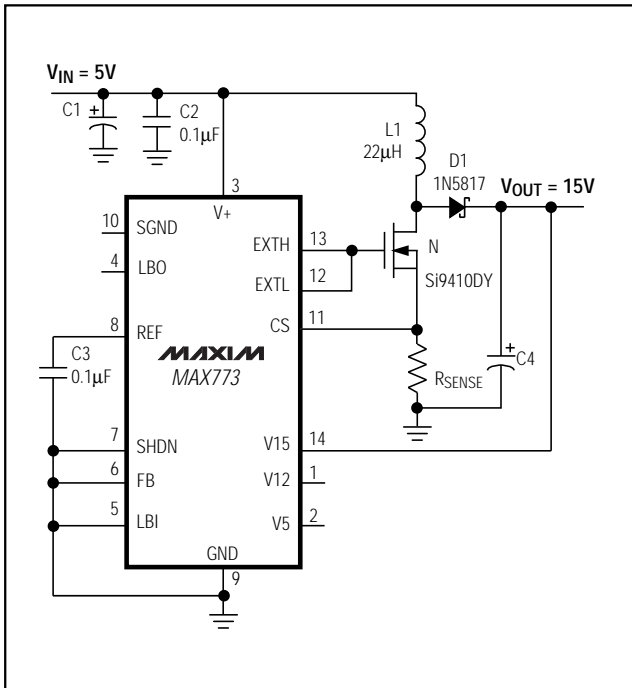

Figure 3c. 15V Preset Output, Non-Bootstrapped N-Channel Power MOSFET

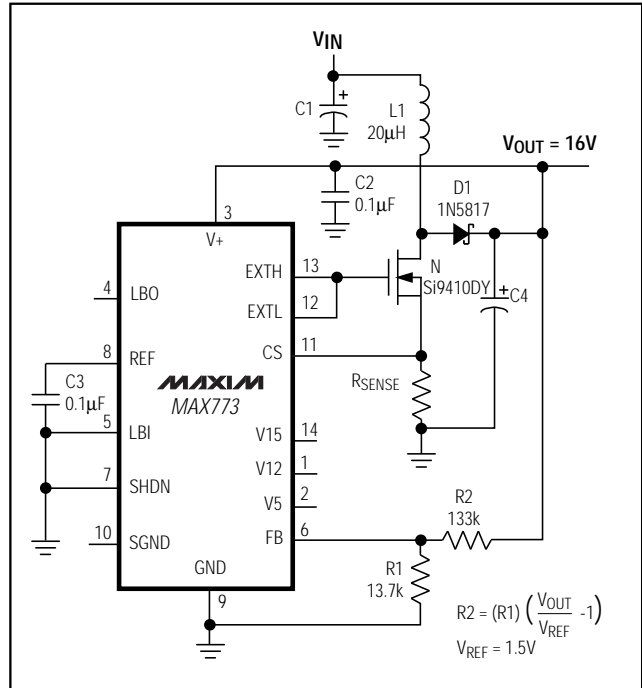

Figure 3d. 16V Output, Bootstrapped, N-Channel Power MOSFET

5V/12V/15V or Adjustable, High-Efficiency, Low IQ, Step-Up DC-DC Controllers

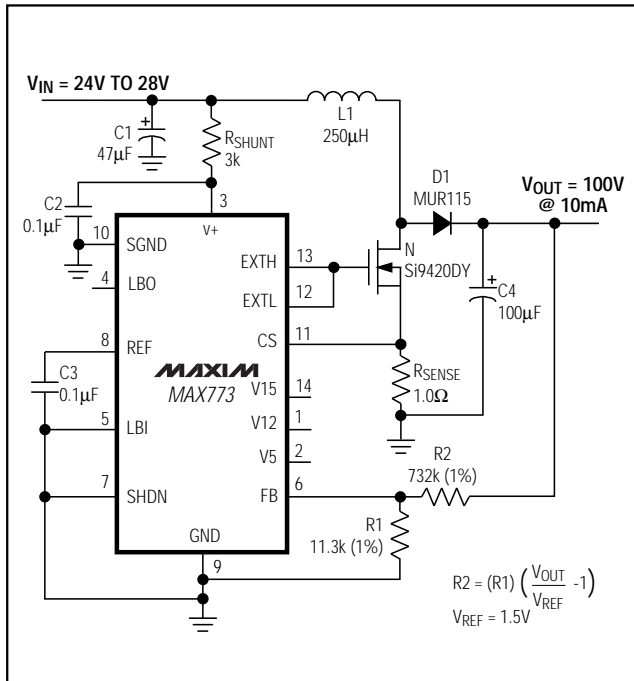

Figure 3e. 100V Output, Shunt Regulator, N-Channel Power MOSFET

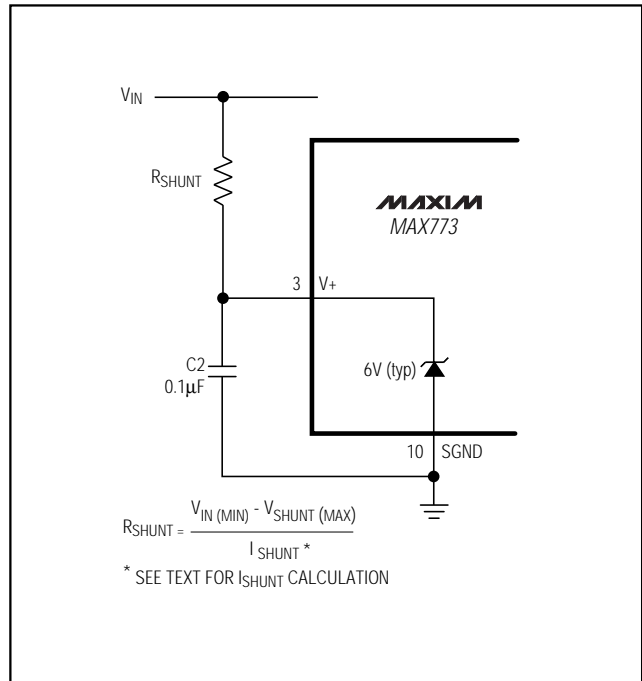

Figure 4. MAX773 Shunt Regulator

turned on, it stays on until either 1) the maximum on-time one-shot turns it off (typically 16µs later), or 2) the switch current reaches the peak current limit set by the current-sense resistor.

To increase light-load efficiency, the current limit for the first two pulses is set to one-half the peak current limit. If those pulses bring the output voltage into regulation, the error comparator holds the MOSFET off and the current limit remains at one-half the peak current limit. If the output voltage is still out of regulation after two pulses, the current limit for the next pulse is raised to the peak current limit set by the external sense resistor (see inductor current waveforms in the *Typical Operating Characteristics*).

The MAX770-MAX773 switching frequency is variable (depending on load current and input voltage), causing variable switching noise. However, the subharmonic noise generated does not exceed the peak current limit times the filter capacitor equivalent series resistance (ESR). For example, when generating a 12V output at 500mA from a 5V input, only 180mV of output ripple occurs using the circuit of Figure 2b.

Low-Voltage Start-Up Oscillator

The MAX770/MAX771/MAX772 feature a low input voltage start-up oscillator that guarantees start-up with no load down to 2V when operating in bootstrapped mode and using internal feedback resistors. At these low voltages, the supply voltage is not large enough for proper error-comparator operation and internal biasing. The start-up oscillator has a fixed 50% duty cycle and the MAX770/MAX771/MAX772 disregard the error-comparator output when the supply voltage is less than 2.5V. Above 2.5V, the error-comparator and normal one-shot timing circuitry are used. The low voltage start-up circuitry is disabled if non-bootstrapped mode is selected (FB is not tied to ground).

The MAX773 does not provide the low-voltage 50% duty-cycle oscillator. Its minimum start-up voltage is 3V for all modes.

External Transistor

An N-FET power switch is recommended for the MAX770/MAX771/MAX772.

The MAX773 can drive either an N-channel MOSFET (N-FET) or an NPN because it provides two separate

5V/12V/15V or Adjustable, High-Efficiency, Low IQ, Step-Up DC-DC Controllers

drive outputs (EXTH and EXTL) that operate 180° out of phase (Figures 3a and 3b). In Figure 3b, the resistor in series with EXTH limits the base current, and EXTL (which is connected directly to the base) turns the transistor off.

Shutdown Mode

When SHDN is high, the MAX770–MAX773 enter shutdown mode. In this mode, the internal biasing circuitry is turned off (including the reference) and V_{OUT} falls to a diode drop below V_{IN} (due to the DC path from the input to the output). In shutdown mode, the supply current drops to less than 5µA. SHDN is a TTL/CMOS logic-level input. Connect SHDN to GND for normal operation.

The MAX773's shunt regulator is **not** disabled in shutdown mode.

Low-Battery Detector

The MAX773 provides a low-battery comparator that compares the voltage on LBI to the reference voltage. When the LBI voltage is below V_{REF} , LBO (an open-drain output) goes low. The low-battery comparator's 20mV of hysteresis adds noise immunity, preventing repeated triggering of LBO. Use a resistor-divider network between V_+ , LBI, and GND to set the desired trip voltage V_{TRIP} . LBO is high impedance in shutdown mode.

Design Procedure

Setting the Output Voltage

To set the output voltage, first determine the mode of operation, either bootstrapped or non-bootstrapped. Bootstrapped mode provides more output current capability, while non-bootstrapped mode reduces the supply current (see *Typical Operating Characteristics*). If a decaying voltage source (such as a battery) is used, see the additional notes in the *Low Input Voltage Operation* section.

Use the MAX770/MAX771/MAX772 unless one or more of the following conditions applies. If one or more of the following is true, use the MAX773:

- 1) An NPN power transistor will be used as the power switch
- 2) The LBI/LBO function is required
- 3) The shunt regulator must accommodate a high input voltage
- 4) Preset-output non-bootstrapped operation is desired—for example, to reduce the no-load supply current in a 5V to 12V application.

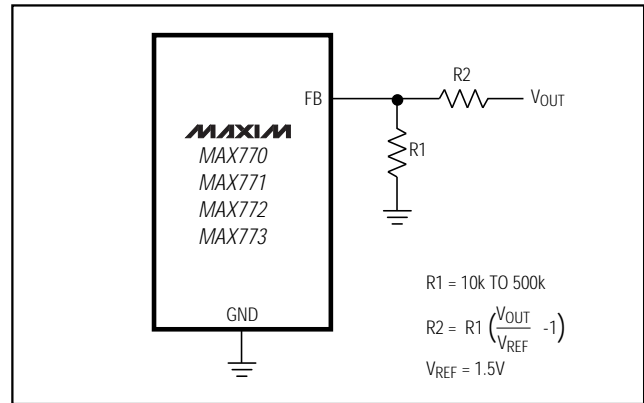

Figure 5. Adjustable Output Circuit

See Table 1 for a summary of operating characteristics and requirements for the ICs in bootstrapped and non-bootstrapped modes.

The MAX770–MAX773's output voltage can be adjusted from very high voltages down to 3V, using external resistors R1 and R2 configured as shown in Figure 5. For adjustable-output operation, select feedback resistor R1 in the range of 10kΩ to 500kΩ. R2 is given by:

$$R2 = (R1) \left(\frac{V_{OUT}}{V_{REF}} - 1 \right)$$

where V_{REF} equals 1.5V.

For preset-output operation, tie FB to GND (this forces bootstrapped-mode operation for the MAX770/MAX771/MAX772).

Configure the MAX773 for a preset voltage of 5V, 12V, or 15V by connecting the output to the corresponding sense input pin (i.e., V5, V12, or V15). FB must be tied to ground for preset-output operation. Leave all unused sense input pins unconnected. Failure to do so will cause an incorrect output voltage. The MAX773 can provide a preset output voltage in both bootstrapped and non-bootstrapped modes.

Figures 2 and 3 show various circuit configurations for bootstrapped/non-bootstrapped, preset/adjustable operation.

Shunt-Regulator Operation

When using the shunt regulator, connect SGND to ground and place a 0.1µF capacitor between V_+ and SGND, as close to the IC as possible. Increase C2 to 1.0µF to improve shunt regulators performance with heavy loads. Select R_{SHUNT} such that $1mA \leq I_{SHUNT} \leq 20mA$.

5V/12V/15V or Adjustable, High-Efficiency, Low IQ, Step-Up DC-DC Controllers

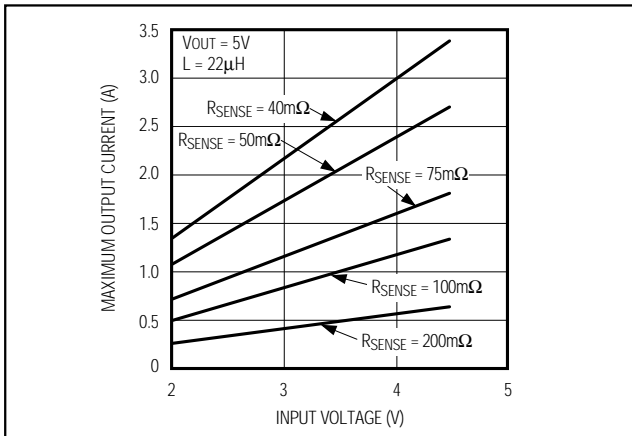

Figure 7a. Maximum Output Current vs. Input Voltage ($V_{OUT} = 5V$)

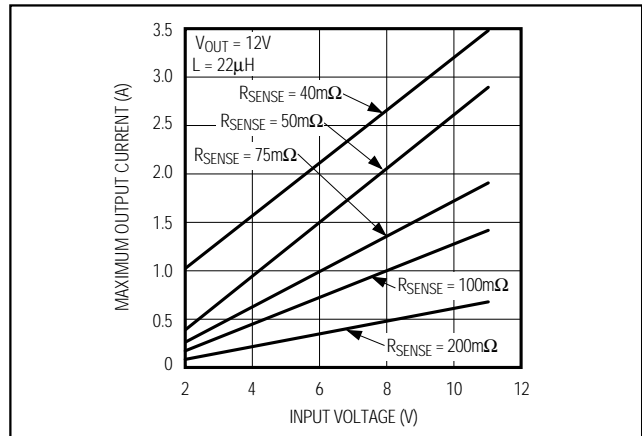

Figure 7b. Maximum Output Current vs. Input Voltage ($V_{OUT} = 12V$)

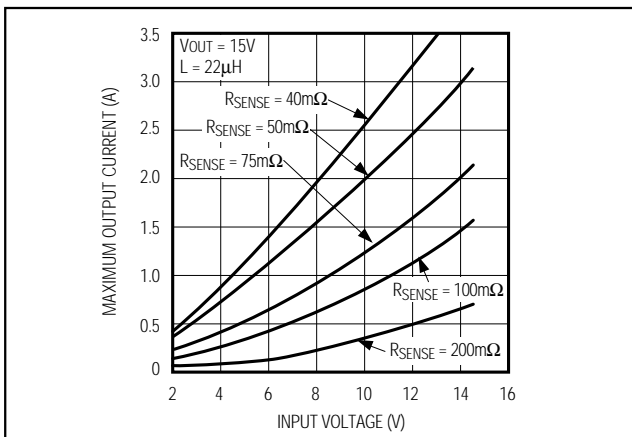

Figure 7c. Maximum Output Current vs. Input Voltage ($V_{OUT} = 15V$)

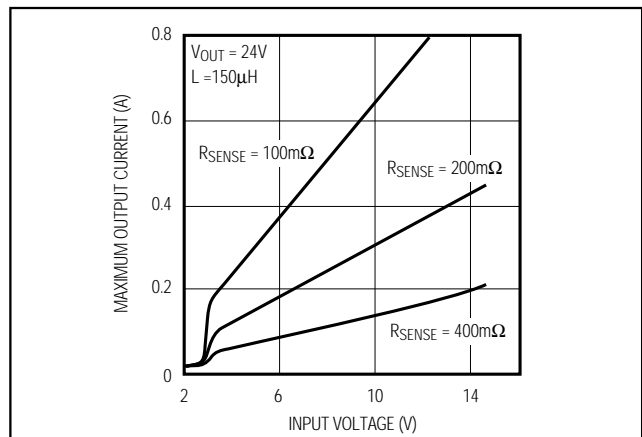

Figure 7d. Maximum Output Current vs. Input Voltage ($V_{OUT} = 24V$)

Determining R_{SENSE}

The *Typical Operating Characteristics* graphs show the output current capability for various modes, sense resistors, and input/output voltages. Use these graphs, along with the theoretical output current curves shown in Figures 7a-7d, to select R_{SENSE} . These theoretical curves assume that an external N-FET power switch is used. They were derived using the minimum (worst-case) current-limit comparator threshold value, and the inductance value. No tolerance was included for R_{SENSE} . The voltage drop across the diode was assumed to be 0.5V, and the drop across the power switch $r_{DS(ON)}$ and coil resistance was assumed to be 0.3V. To use the graphs, locate the graph with the appropriate output voltage or the graph having the nearest output voltage higher than the desired output voltage. On this graph, find the curve for the largest

sense-resistor value with an output current that is adequate at the lowest input voltage.

Determining the Inductor (L)

Practical inductor values range from 10 μ H to 300 μ H. 20 μ H is a good choice for most applications. In applications with large input/output differentials, the IC's output current capability will be much less when the inductance value is too low, because the IC will always operate in discontinuous mode. If the inductor value is too low, the current will ramp up to a high level before the current-limit comparator can turn off the switch. The minimum on-time for the switch ($t_{ON(min)}$) is approximately 2 μ s; select an inductor that allows the current to ramp up to $I_{LIM}/2$ in no less than 2 μ s. Choosing a value of $I_{LIM}/2$ allows the half-size current pulses to occur, increasing light-load efficiency and minimizing output ripple.

5V/12V/15V or Adjustable, High-Efficiency, Low IQ, Step-Up DC-DC Controllers

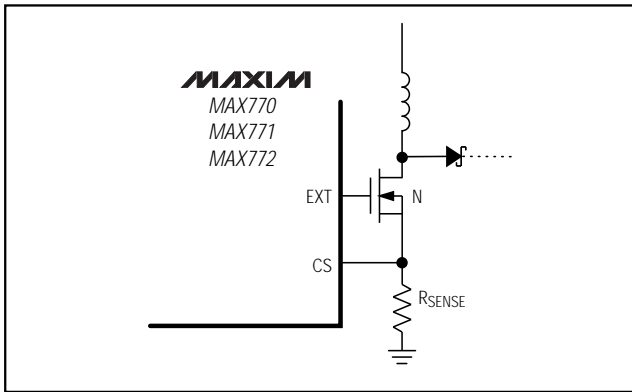

Figure 8a. Use an N-Channel MOSFET with the MAX770/MAX771/MAX772

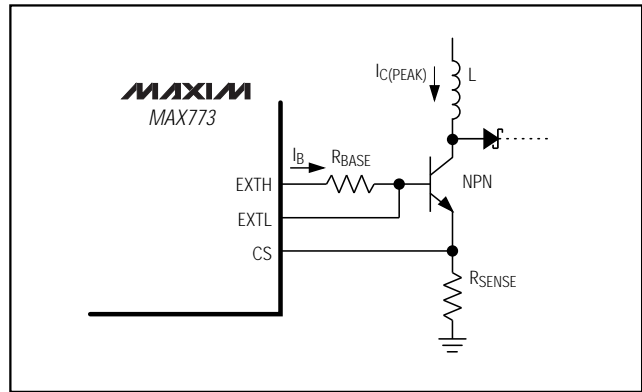

Figure 8c. Using an NPN Transistor with the MAX773

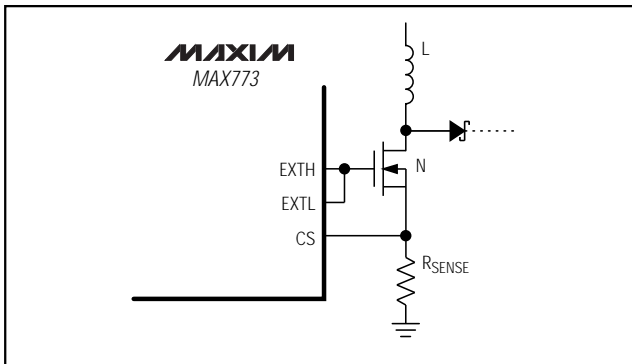

Figure 8b. Using an N-Channel MOSFET with the MAX773

The standard operating circuits use a 22μH inductor. If a different inductance value is desired, select L such that:

$$L \geq \frac{V_{IN(max)} \times t_{ON(min)}}{I_{LIM}/2}$$

Larger inductance values tend to increase the start-up time slightly, while smaller inductance values allow the coil current to ramp up to higher levels before the switch turns off, increasing the ripple at light loads.

Inductors with a ferrite core or equivalent are recommended; powder iron cores are not recommended for use with high switching frequencies. Make sure the inductor's saturation current rating (the current at which the core begins to saturate and the inductance starts to fall) exceeds the peak current rating set by RSENSE. However, it is generally acceptable to bias the inductor into saturation by approximately 20% (the point where the inductance is 20% below the nominal value). For highest efficiency, use a coil with low DC resistance,

preferably under 20mΩ. To minimize radiated noise, use a toroid, a pot core, or a shielded coil.

Table 2 lists inductor suppliers and specific recommended inductors.

Power Transistor Selection

Use an N-channel MOSFET power transistor with the MAX770/MAX771/MAX772 (Figure 8a).

Use an N-FET whenever possible with the MAX773. An NPN transistor can be used, but be extremely careful when determining the base current (see *NPN Transistors* section). An NPN transistor is not recommended when using the shunt regulator.

N-Channel MOSFETs

To ensure the external N-channel MOSFET (N-FET) is turned on hard, use logic-level or low-threshold N-FETs when the input drive voltage is less than 8V. This applies even in bootstrapped mode, to ensure start-up.

N-FETs provide the highest efficiency because they do not draw any DC gate-drive current, but they are typically more expensive than NPN transistors. When using an N-FET with the MAX773, connect EXTH and EXTL to the N-FET's gate (Figure 8b).

When selecting an N-FET, three important parameters are the total gate charge (Q_g), on resistance (r_{DS(ON)}), and reverse transfer capacitance (C_{rss}).

Q_g takes into account all capacitances associated with charging the gate. Use the typical Q_g value for best results; the maximum value is usually grossly over-specified since it is a guaranteed limit and not the measured value. The typical total gate charge should be 50nC or less. With larger numbers, the EXT pins may not be able to adequately drive the gate. The EXT rise/fall time with various capacitive loads as shown in the *Typical Operating Characteristics*.

5V/12V/15V or Adjustable, High-Efficiency, Low IQ, Step-Up DC-DC Controllers

The two most significant losses contributing to the N-FET's power dissipation are I^2R losses and switching losses. Select a transistor with low $r_{DS(ON)}$ and low C_{RSS} to minimize these losses.

Determine the maximum required gate-drive current from the Q_g specification in the N-FET data sheet.

The MAX773's maximum allowed switching frequency during normal operation is 300kHz; but at start-up the maximum frequency can be 500kHz, so the maximum current required to charge the N-FET's gate is $f(\max) \times Q_g(\text{typ})$. Use the typical Q_g number from the transistor data sheet. For example, the Si9410DY has a $Q_g(\text{typ})$ of 17nC (at $V_{GS} = 5V$), therefore the current required to charge the gate is:

$$I_{GATE}(\max) = (500\text{kHz})(17\text{nC}) = 8.5\text{mA}.$$

The bypass capacitor on V_+ (C_2) must instantaneously furnish the gate charge without excessive droop (e.g., less than 200mV):

$$\Delta V_+ = \frac{Q_g}{C_2}$$

Continuing with the example, $\Delta V_+ = 17\text{nC}/0.1\mu\text{F} = 170\text{mV}$.

Use I_{GATE} when calculating the appropriate shunt resistor. See the *Shunt Regulator Operation* section.

Figure 2a's application circuit uses an MTD3055EL logic-level N-FET with a guaranteed threshold voltage (V_{TH}) of 2V. Figure 2b's application circuit uses an 8-pin Si9410DY surface-mount N-FET that has 50m Ω on resistance with 4.5V V_{GS} , and a guaranteed V_{TH} of less than 3V.

NPN Transistors

The MAX773 can drive NPN transistors, but be extremely careful when determining the base-current requirements. Too little base current can cause excessive power dissipation in the transistor; too much base current can cause the base to oversaturate, so the transistor remains on continually. Both conditions can damage the transistor.

When using the MAX773 with an NPN transistor, connect EXTL to the transistor's base, and connect R_{BASE} between EXTH and the base (Figure 8c).

To determine the required peak inductor current, $I_{C(PEAK)}$, observe the *Typical Operating Characteristics* efficiency graphs and the theoretical output current capability vs. input voltage graphs to determine a sense resistor that will allow the desired output current. Divide the 170mV worst-case (smallest) voltage across the current-sense amplifier $V_{CS(\max)}$ by the sense-resistor value. To determine I_B , set the peak inductor current (I_{LIM}) equal to the peak transistor collector cur-

rent $I_{C(PEAK)}$. Calculate I_B as follows:

$$I_B = I_{LIM}/\beta$$

Use the worst-case (lowest) value for β given in the transistor's electrical specification, where the collector current used for the test is approximately equal to I_{LIM} . It may be necessary to use even higher base currents (e.g., $I_B = I_{LIM}/10$), although excessive I_B may impair operation by extending the transistor's turn-off time.

R_{BASE} is determined by:

$$R_{BASE} = \frac{(V_{EXTH} - V_{BE} - V_{CS(\min)})}{I_B}$$

Where V_{EXTH} is the voltage at V_+ (in bootstrapped mode V_{EXTH} is the output voltage), V_{BE} is the 0.7V transistor base-emitter voltage, $V_{CS(\min)}$ is the voltage drop across the current-sense resistor, and I_B is the minimum base current that forces the transistor into saturation. This equation reduces to $(V_+ - 700\text{mV} - 170\text{mV}) / I_B$.

For maximum efficiency, make R_{BASE} as large as possible, but small enough to ensure the transistor is always driven near saturation. Highest efficiency is obtained with a fast-switching NPN transistor ($f_T \geq 150\text{MHz}$) with a low collector-emitter saturation voltage and a high current gain. A good transistor to use is the Zetex ZTX694B.

Diode Selection

The MAX770-MAX773's high switching frequency demands a high-speed rectifier. Schottky diodes such as the 1N5817-1N5822 are recommended. Make sure that the Schottky diode's average current rating exceeds the peak current limit set by R_{SENSE} , and that its breakdown voltage exceeds V_{OUT} . For high-temperature applications, Schottky diodes may be inadequate due to their high leakage currents; high-speed silicon diodes may be used instead. At heavy loads and high temperatures, the benefits of a Schottky diode's low forward voltage may outweigh the disadvantages of its high leakage current.

Capacitor Selection

Output Filter Capacitor

The primary criterion for selecting the output filter capacitor (C_2) is low effective series resistance (ESR). The product of the peak inductor current and the output filter capacitor's ESR determines the amplitude of the ripple seen on the output voltage. An OS-CON 300 μF , 6.3V output filter capacitor has approximately 50m Ω of ESR and typically provides 180mV ripple when stepping up from 3V to 5V at 1A (Figure 2a).

5V/12V/15V or Adjustable, High-Efficiency, Low IQ, Step-Up DC-DC Controllers

Smaller capacitors are acceptable for light loads or in applications that can tolerate higher output ripple.

Since the output filter capacitor's ESR affects efficiency, use low-ESR capacitors for best performance. The smallest low-ESR surface-mount tantalum capacitors currently available are the Sprague 595D series. Sanyo OS-CON organic semiconductor through-hole capacitors and the Nichicon PL series also exhibit low ESR. See Table 2.

Input Bypass Capacitors

The input bypass capacitor (C1) reduces peak currents drawn from the voltage source and also reduces noise at the voltage source caused by the switching action of the MAX770-MAX773. The input voltage source impedance determines the size of the capacitor required at the V+ input. As with the output filter capacitor, a low-ESR capacitor is recommended. For output currents up to 1A, 150 μ F (C1) is adequate, although smaller bypass capacitors may also be acceptable.

Bypass the IC with a 0.1 μ F ceramic capacitor (C2) placed close to the V+ and GND pins.

Reference Capacitor

Bypass REF with a 0.1 μ F capacitor (C3). REF can source up to 100 μ A of current.

Setting the Low-Battery-Detector Voltage

To set the low-battery detector's falling trip voltage ($V_{TRIP(falling)}$), select R3 between 10k Ω and 500k Ω (Figure 9), and calculate R4 as follows:

$$R4 = (R3) \left(\frac{V_{TRIP} - V_{REF}}{V_{REF}} \right)$$

where $V_{REF} = 1.5V$.

The rising trip voltage is higher because of the comparator's approximately 20mV of hysteresis, and is determined by:

$$V_{TRIP}(\text{rising}) = (V_{REF} + 20mV) \left(1 + \frac{R4}{R3} \right)$$

Connect a high value resistor (larger than $R3 + R4$) between LBI and LBO if additional hysteresis is required.

Connect a pull-up resistor (e.g., 100k Ω) between LBO and V+. Tie LBI to GND and leave LBO floating if the low-battery detector is not used.

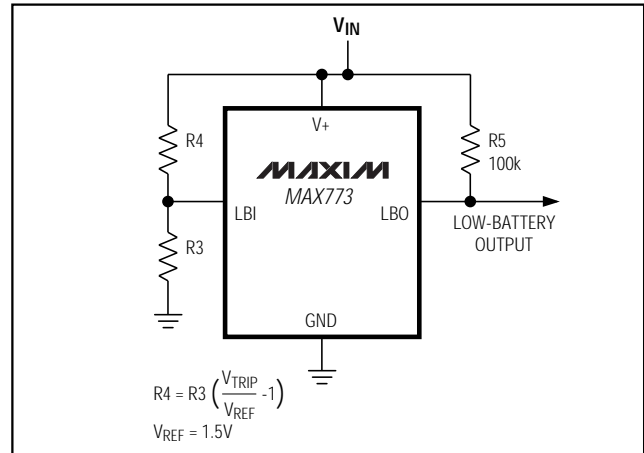

Figure 9. Input Voltage Monitor Circuit

Applications Information

MAX773 Operation with High Input/Output Voltages

The MAX773's shunt regulator input allows high voltages to be converted to very high voltages. Since the MAX773 runs off the 6V shunt (bootstrapped operation is not allowed), the IC will not see the high input voltage. Use an external logic-level N-FET as the power switch, since only 6V of V_{GS} are available. Also, make sure all external components are rated for very high output voltage. Figure 3e shows a circuit that converts 28V to 100V.

Low Input Voltage Operation

When using a power supply that decays with time (such as a battery), the N-FET transistor will operate in its linear region when the voltage at EXT approaches the threshold voltage of the FET, dissipating excessive power. Prolonged operation in this mode may damage the FET. This effect is much more significant in non-bootstrapped mode than in bootstrapped mode, since bootstrapped mode typically provides much higher V_{GS} voltages. To avoid this condition, make sure V_{EXT} is above the V_{TH} of the FET, or use a voltage detector (such as the MAX8211) to put the IC in shutdown mode once the input supply voltage falls below a predetermined minimum value. Excessive loads with low input voltages can also cause this condition.

5V/12V/15V or Adjustable, High-Efficiency, Low IQ, Step-Up DC-DC Controllers

MAX770-MAX773

Starting Up under Load

The *Typical Operating Characteristics* show the Start-Up Voltage vs. Load Current graph for bootstrapped-mode operation. This graph depends on the type of power switch used. The MAX770-MAX773 are not designed to start up under full load in bootstrapped mode with low input voltages.

Layout Considerations

Due to high current levels and fast switching waveforms, which radiate noise, proper PC board layout is essential. Protect sensitive analog grounds by using a star ground configuration. Minimize ground noise by connecting GND, the input bypass capacitor ground

lead, and the output filter capacitor ground lead to a single point (star ground configuration). Also, minimize lead lengths to reduce stray capacitance, trace resistance, and radiated noise. Place input bypass capacitor C2 as close as possible to V+ and GND.

Excessive noise at the V+ input may falsely trigger the timing circuitry, resulting in short pulses at EXT. If this occurs it will have a negligible effect on circuit efficiency. If desired, place a 4.7 μ F directly across the V+ and GND pins (in parallel with the 0.1 μ F C2 bypass capacitor) to reduce the noise at V+.

Table 2. Component Suppliers

PRODUCTION	INDUCTORS	CAPACITORS	TRANSISTORS	DIODES
Surface Mount	Sumida CD54 series CDR125 series Coiltronics CTX20 series	Matsuo 267 series Sprague 595D series	N-FET Siliconix Si9410DY Si9420DY (high voltage) Motorola MTP3055EL MTD20N03HDL	Nihon EC10 series
Through Hole	Sumida RCH855 series RCH110 series Renco RL1284-18	Sanyo OS-CON series Nichicon PL series United Chemi-Con LXF series	NPN Zetex ZTX694B	Motorola 1N5817-1N5822 MUR115 (high voltage)

SUPPLIER	PHONE	FAX
Coiltronics	USA: (561) 241-7876	(561) 241-9339
Matsuo	USA: (714) 969-2491 Japan: 81-6-337-6450	(714) 960-6492 81-6-337-6456
Nichicon	USA: (847) 843-7500	(847) 843-2798
Nihon	USA: (805) 867-2555	(805) 867-2698
Renco	USA: (516) 586-5566	(516) 586-5562
Sanyo	USA: (619) 661-6835 Japan: 81-7-2070-6306	(619) 661-1055 81-7-2070-1174
Sumida	USA: (847) 956-0666 Japan: 81-3-3607-5111	81-3-3607-5144
United Chemi-Con	USA: (714) 255-9500	(714) 255-9400
Zetex	USA: (516) 543-7100 UK: 44-61-627-4963	(516) 864-7630 44-61-627-5467

5V/12V/15V or Adjustable, High-Efficiency, Low IQ, Step-Up DC-DC Controllers

Ordering Information (continued)

PART	TEMP. RANGE	PIN-PACKAGE
MAX771 CPA	0°C to +70°C	8 Plastic DIP
MAX771CSA	0°C to +70°C	8 SO
MAX771C/D	0°C to +70°C	Dice*
MAX771EPA	-40°C to +85°C	8 Plastic DIP
MAX771ESA	-40°C to +85°C	8 SO
MAX771MJA	-55°C to +125°C	8 CERDIP
MAX772 CPA	0°C to +70°C	8 Plastic DIP
MAX772CSA	0°C to +70°C	8 SO
MAX772C/D	0°C to +70°C	Dice*
MAX772EPA	-40°C to +85°C	8 Plastic DIP
MAX772ESA	-40°C to +85°C	8 SO
MAX772MJA	-55°C to +125°C	8 CERDIP
MAX773 CPD	0°C to +70°C	14 Plastic DIP
MAX773CSD	0°C to +70°C	14 SO
MAX773C/D	0°C to +70°C	Dice*
MAX773EPD	-40°C to +85°C	14 Plastic DIP
MAX773ESD	-40°C to +85°C	14 Narrow SO
MAX773MJD	-55°C to +125°C	14 CERDIP

*Contact factory for dice specifications.

Pin Configurations (continued)

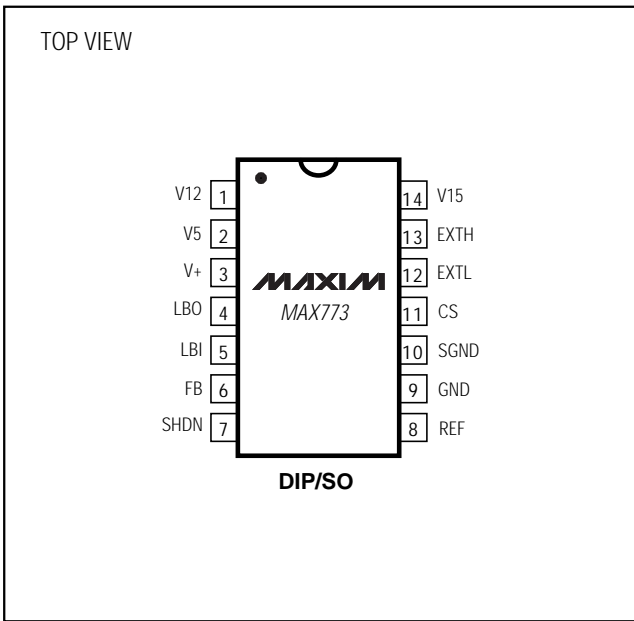

Chip Topographies

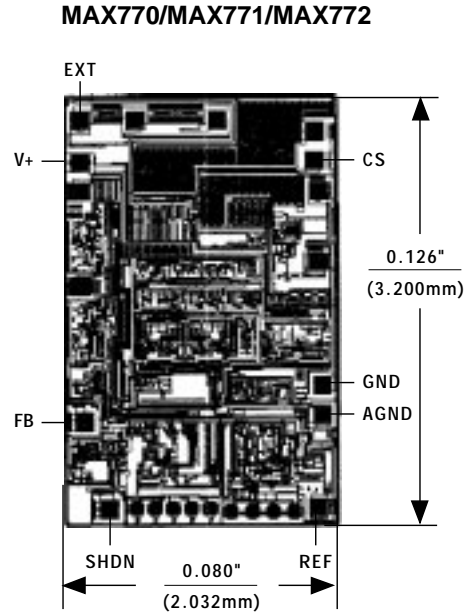

TRANSISTOR COUNT: 501;
SUBSTRATE CONNECTED TO V+.

MAX773

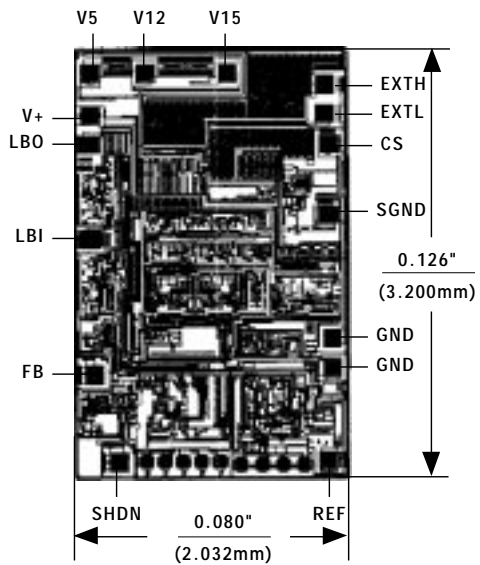

TRANSISTOR COUNT: 501;
SUBSTRATE CONNECTED TO V+.