



## 20 $\mu$ A, 1/8-Unit-Load, Slew-Rate-Limited RS-485 Transceivers

MAX1482/MAX1483

### General Description

The MAX1482 and MAX1483 are low-power transceivers for RS-485 and RS-422 communication. Both feature slew-rate-limited drivers that minimize EMI and reduce reflections caused by improperly terminated cables. Data rates are guaranteed up to 250kbps.

The MAX1482/MAX1483 draw only 20 $\mu$ A of supply current. Additionally, they have a low-current shutdown mode that consumes only 0.1 $\mu$ A. Both parts operate from a single +5V supply.

Drivers are short-circuit current limited and are protected against excessive power dissipation by thermal shutdown circuitry that places the driver outputs into a high-impedance state. The receiver input has a fail-safe feature that guarantees a logic-high output if the input is open circuit.

The MAX1482 is full duplex and the MAX1483 is half duplex. Both parts have a 1/8-unit-load input impedance that guarantees up to 256 transceivers on the bus.

### Applications

- Low-Power RS-485/RS-422 Networks
- Transceivers for EMI-Sensitive Applications
- Industrial-Control Local Area Networks
- Large 256-Node LANs

### Typical Operating Circuits

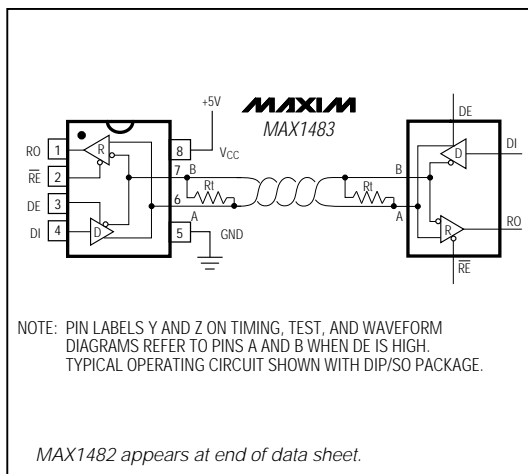

### Features

- ◆ Low 20 $\mu$ A Operating Current
- ◆ Slew-Rate Limited for Reduced EMI and Reduced Reflections
- ◆ 0.1 $\mu$ A Low-Current Shutdown Mode
- ◆ Designed for RS-485 and RS-422 Applications
- ◆ Operate from a Single +5V Supply
- ◆ -7V to +12V Common-Mode Input Voltage Range
- ◆ Allows up to 256 Transceivers on the Bus—Guaranteed (1/8-unit load)
- ◆ Current Limiting and Thermal Shutdown for Driver Overload Protection

### Ordering Information

PART	TEMP. RANGE	PIN-PACKAGE
MAX1482CPD	0°C to +70°C	14 Plastic DIP
MAX1482CSD	0°C to +70°C	14 SO
MAX1482EPD	-40°C to +85°C	14 Plastic DIP
MAX1482ESD	-40°C to +85°C	14 SO
MAX1483CPA	0°C to +70°C	8 Plastic DIP
MAX1483CSA	0°C to +70°C	8 SO
MAX1483CUA	0°C to +70°C	8 $\mu$ MAX
MAX1483EPA	-40°C to +85°C	8 Plastic DIP
MAX1483ESA	-40°C to +85°C	8 SO

### Pin Configurations

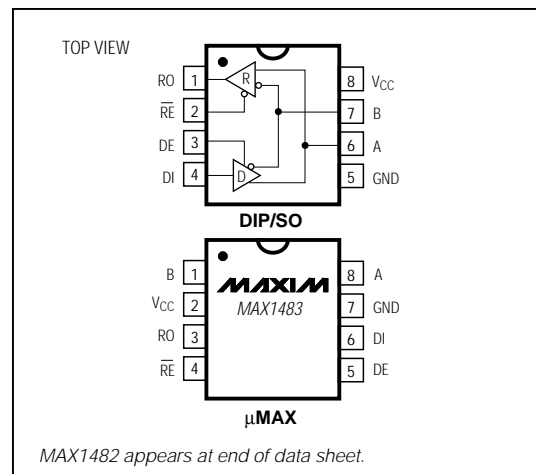

# 20 $\mu$ A, 1/8-Unit-Load, Slew-Rate-Limited RS-485 Transceivers

MAX1482/MAX1483

## ABSOLUTE MAXIMUM RATINGS

Supply Voltage (V <sub>CC</sub> )	.....7V	8-Pin SO (derate 5.88mW/°C above +70°C)	.....471mW
Control Input Voltages ( $\overline{RE}$ , DE)	.....-0.5V to (V <sub>CC</sub> + 0.5V)	14-Pin SO (derate 8.33mW/°C above +70°C)	.....667mW
Driver Input Voltage (DI)	.....-0.5V to (V <sub>CC</sub> + 0.5V)	8-Pin $\mu$ MAX (derate 4.10mW/°C above +70°C)	.....330mW
Driver Output Voltages	.....-7.5V to 12.5V	Operating Temperature Ranges	
Receiver Input Voltages (A, B)	.....-7.5V to 12.5V	MAX148_C_	.....0°C to +70°C
Receiver Output Voltage (RO)	.....-0.5V to (V <sub>CC</sub> + 0.5V)	MAX148_E_	.....-40°C to +85°C
Continuous Power Dissipation (T <sub>A</sub> = +70°C)		Storage Temperature Range	.....-65°C to +160°C
8-Pin Plastic DIP (derate 9.09mW/°C above +70°C)	.....727mW	Lead Temperature (soldering, 10sec)	.....+300°C
14-Pin Plastic DIP (derate 10.00mW/°C above +70°C)	.....800mW		

Stresses beyond those listed under "Absolute Maximum Ratings" may cause permanent damage to the device. These are stress ratings only, and functional operation of the device at these or any other conditions beyond those indicated in the operational sections of the specifications is not implied. Exposure to absolute maximum rating conditions for extended periods may affect device reliability.

## DC ELECTRICAL CHARACTERISTICS

(V<sub>CC</sub> = 5V  $\pm$ 5%, T<sub>A</sub> = T<sub>MIN</sub> to T<sub>MAX</sub>, unless otherwise noted. Typical values are at T<sub>A</sub> = +25°C.) (Note 1)

PARAMETER	SYMBOL	CONDITIONS	MIN	TYP	MAX	UNITS
Differential Driver Output (no load)	V <sub>OD1</sub>				5	V
Differential Driver Output (with load)	V <sub>OD2</sub>	R = 50 $\Omega$ (RS-422), Figure 1	2		5	V
		R = 27 $\Omega$ (RS-485), Figure 1	1.5		5	
Change in Magnitude of Driver Differential Output Voltage for Complementary Output States	$\Delta$ V <sub>OD</sub>	R = 27 $\Omega$ or 50 $\Omega$ , Figure 1			0.2	V
Driver Common-Mode Output Voltage	V <sub>OC</sub>	R = 27 $\Omega$ or 50 $\Omega$ , Figure 1			3	V
Change in Magnitude of Driver Common-Mode Output Voltage for Complementary Output States	$\Delta$ V <sub>OC</sub>	R = 27 $\Omega$ or 50 $\Omega$ , Figure 1			0.2	V
Three-State (high impedance) Output Current at Driver	I <sub>OZD</sub>	MAX1482 only, -7V < V <sub>Y</sub> and V <sub>Z</sub> < 12V			$\pm$ 50	$\mu$ A
Logic Input High Voltage	V <sub>IH</sub>	DE, DI, $\overline{RE}$	2.0			V
Logic Input Low Voltage	V <sub>IL</sub>	DE, DI, $\overline{RE}$			0.8	V
Logic Input Current	I <sub>IN1</sub>	DE, DI, $\overline{RE}$			$\pm$ 2	$\mu$ A
Input Current (A, B)	I <sub>IN2</sub>	MAX1482, DE = 0V, V <sub>CC</sub> = 0V or 5.25V	V <sub>IN</sub> = 12V		150	$\mu$ A
			V <sub>IN</sub> = -7V		-100	
		MAX1483, DE = 0V, V <sub>CC</sub> = 0V or 5.25V	V <sub>IN</sub> = 12V		200	
			V <sub>IN</sub> = -7V		-150	
Receiver Differential Threshold Voltage	V <sub>TH</sub>	-7V $\leq$ V <sub>CM</sub> $\leq$ 12V	-0.2		0.2	V
Receiver Input Hysteresis	$\Delta$ V <sub>TH</sub>	V <sub>CM</sub> = 0V		75		mV
Receiver Output High Voltage	V <sub>OH</sub>	I <sub>O</sub> = -4mA, V <sub>ID</sub> = 200mV	3.5			V
Receiver Output Low Voltage	V <sub>OL</sub>	I <sub>O</sub> = 4mA, V <sub>ID</sub> = -200mV			0.4	V
Three-State (high impedance) Output Current at Receiver	I <sub>OZR</sub>	0.4V $\leq$ V <sub>O</sub> $\leq$ 2.4V			$\pm$ 1	$\mu$ A
Receiver Input Resistance	R <sub>IN</sub>	-7V $\leq$ V <sub>CM</sub> $\leq$ 12V	96			k $\Omega$

**Note 1:** All currents into device pins are positive; all currents out of device pins are negative. All voltages are referenced to device ground unless otherwise specified.

# 20 $\mu$ A, 1/8-Unit-Load, Slew-Rate-Limited RS-485 Transceivers

MAX1482/MAX1483

## DC ELECTRICAL CHARACTERISTICS (continued)

( $V_{CC} = 5V \pm 5\%$ ,  $T_A = T_{MIN}$  to  $T_{MAX}$ , unless otherwise noted. Typical values are at  $T_A = +25^\circ C$ .) (Note 1)

PARAMETER	SYMBOL	CONDITIONS	MIN	TYP	MAX	UNITS
No-Load Supply Current	$I_{CC}$	MAX1482, $\overline{RE} = 0V$ or $V_{CC}$	$DE = V_{CC}$	25	45	$\mu A$
			$DE = 0V$	20	35	
		MAX1483, $\overline{RE} = 0V$ or $V_{CC}$	$DE = V_{CC}$	55	85	
			$DE = 0V$	20	35	
Supply Current in Shutdown	$I_{SHDN}$	$DE = 0V, \overline{RE} = V_{CC}$	0.1	10	$\mu A$	
Driver Short-Circuit Current	$I_{OSD}$	$DI = \text{high or low}, -7V \leq V_O \leq 12V$ (Note 2)	35		250	$mA$
Receiver Short-Circuit Current	$I_{OSR}$	$0V \leq V_O \leq V_{CC}$	$\pm 7$		$\pm 95$	$mA$

## SWITCHING CHARACTERISTICS

( $V_{CC} = 5V \pm 5\%$ ,  $T_A = T_{MIN}$  to  $T_{MAX}$ , unless otherwise noted. Typical values are at  $T_A = +25^\circ C$ .) (Note 1)

PARAMETER	SYMBOL	CONDITIONS	MIN	TYP	MAX	UNITS
Driver Input to Output	$t_{PLH}$	Figures 3 and 5, $R_{DIFF} = 54\Omega$ , $C_{L1} = C_{L2} = 100pF$			2	$\mu s$
	$t_{PHL}$				2	
Driver Output Skew to Output	$t_{SKEW}$	Figures 3 and 5, $R_{DIFF} = 54\Omega$ , $C_{L1} = C_{L2} = 100pF$			800	$ns$
Driver Rise or Fall Time	$t_R, t_F$	Figures 3 and 5, $R_{DIFF} = 54\Omega$ , $C_{L1} = C_{L2} = 100pF$	0.25		2	$\mu s$
Driver Enable to Output High	$t_{ZH}$	Figures 4 and 6, $C_L = 100pF$ , $S_2$ closed	0.2		2	$\mu s$
Driver Enable to Output Low	$t_{ZL}$	Figures 4 and 6, $C_L = 100pF$ , $S_1$ closed	0.1		2	$\mu s$
Driver Disable Time from Low	$t_{LZ}$	Figures 4 and 6, $C_L = 15pF$ , $S_1$ closed	0.3		3.0	$\mu s$
Driver Disable Time from High	$t_{HZ}$	Figures 4 and 6, $C_L = 15pF$ , $S_2$ closed	0.3		3.0	$\mu s$
Receiver Input to Output	$t_{PLH}, t_{PHL}$	Figures 3 and 7, $R_{DIFF} = 54\Omega$ , $C_{L1} = C_{L2} = 100pF$	0.25		2.25	$\mu s$
$ t_{PLH} - t_{PHL} $ Differential Receiver Skew	$t_{SKD}$	Figures 3 and 7, $R_{DIFF} = 54\Omega$ , $C_{L1} = C_{L2} = 100pF$		160		$ns$
Receiver Enable to Output Low	$t_{ZL}$	Figures 2 and 8, $C_{RL} = 15pF$ , $S_1$ closed			90	$ns$
Receiver Enable to Output High	$t_{ZH}$	Figures 2 and 8, $C_{RL} = 15pF$ , $S_2$ closed			90	$ns$
Receiver Disable Time from Low	$t_{LZ}$	Figures 2 and 8, $C_{RL} = 15pF$ , $S_1$ closed			90	$ns$
Receiver Disable Time from High	$t_{HZ}$	Figures 2 and 8, $C_{RL} = 15pF$ , $S_2$ closed			90	$ns$
Maximum Data Rate	$f_{MAX}$		250			$kbps$
Time to Shutdown	$t_{SHDN}$	(Note 3)	50	200	600	$ns$
Driver Enable from Shutdown to Output High	$t_{ZH}(SHDN)$	Figures 4 and 6, $C_L = 100pF$ , $S_2$ closed			2	$\mu s$
Driver Enable from Shutdown to Output Low	$t_{ZL}(SHDN)$	Figures 4 and 6, $C_L = 100pF$ , $S_1$ closed			2	$\mu s$
Receiver Enable from Shutdown to Output High	$t_{ZH}(SHDN)$	Figures 2 and 8, $C_L = 15pF$ , $S_2$ closed, $A - B = 2V$			3	$\mu s$
Receiver Enable from Shutdown to Output Low	$t_{ZL}(SHDN)$	Figures 2 and 8, $C_L = 15pF$ , $S_1$ closed, $B - A = 2V$			3	$\mu s$

**Note 2:** Applies to peak current. See *Typical Operating Characteristics*.

**Note 3:** The MAX1482/MAX1483 are put into shutdown by bringing  $\overline{RE}$  high and  $DE$  low. If the inputs are in this state for less than 50ns, the parts are guaranteed not to enter shutdown. If the inputs are in this state for at least 600ns, the parts are guaranteed to have entered shutdown. See *Low-Power Shutdown Mode* section.

# 20 $\mu$ A, 1/8-Unit-Load, Slew-Rate-Limited RS-485 Transceivers

## Typical Operating Characteristics

(T<sub>A</sub> = +25°C, unless otherwise noted.)

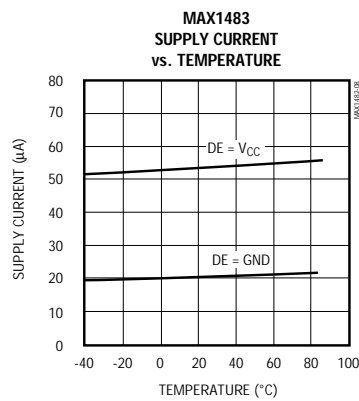
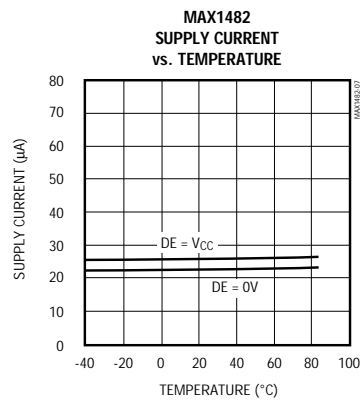
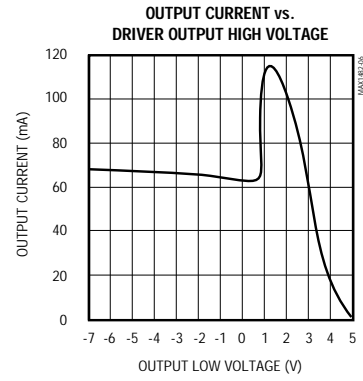
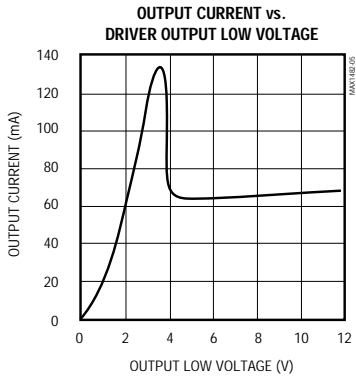
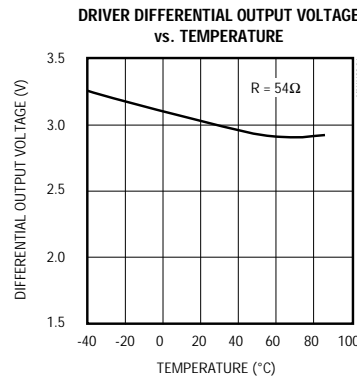
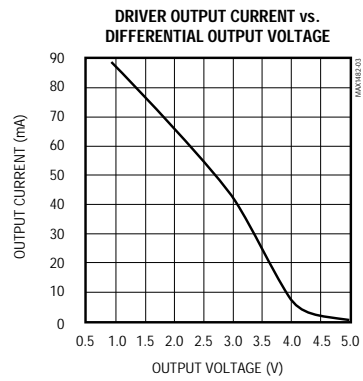
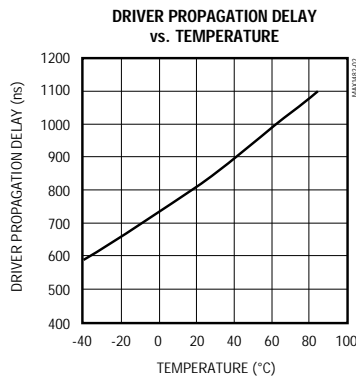
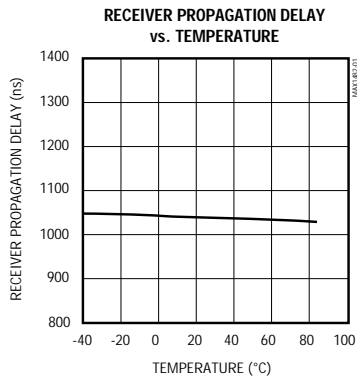

## 20 $\mu$ A, 1/8-Unit-Load, Slew-Rate-Limited RS-485 Transceivers

### Pin Description

MAX1482/MAX1483

PIN			NAME	FUNCTION
MAX1482	MAX1483			
DIP/SO	DIP/SO	$\mu$ MAX		
2	1	3	RO	Receiver Output. With the receiver output enabled ( $\overline{RE}$ low), RO is high if $A > B$ by 200mV or when A and B are not connected, and RO is low if $A < B$ by 200mV.
3	2	4	$\overline{RE}$	Receiver Output Enable. When $\overline{RE}$ is low, RO is enabled. When $\overline{RE}$ is high, RO is high impedance. If $\overline{RE}$ is high and DE is low, the MAX1482/MAX1483 enter a low-power (0.1 $\mu$ A) shutdown state.
4	3	5	DE	Driver Output Enable. The driver outputs, A and B, (Y and Z for the MAX1482) are enabled by bringing DE high. When DE is low, the driver outputs are high impedance, and the devices can function as line receivers if $\overline{RE}$ is low. If $\overline{RE}$ is high and DE is low, the parts will enter a low-power (0.1 $\mu$ A) shutdown state. If the driver outputs are enabled, the devices function as line drivers.
5	4	6	DI	Driver Input. With DE high, a low on DI forces output Y low and output Z high, and a high on DI forces output Y high and output Z low.
6, 7	5	7	GND	Ground
9	—	—	Y	Noninverting Driver Output
10	—	—	Z	Inverting Driver Output
—	6	8	A	Noninverting Receiver Input and Noninverting Driver Output
12	—	—	A	Noninverting Receiver Input
—	7	1	B	Inverting Receiver Input and Inverting Driver Output
11	—	—	B	Inverting Receiver Input
14	8	2	VCC	Positive Supply: 4.75V to 5.25V
1, 8, 13	—	—	N.C.	No Connect—not internally connected

# 20 $\mu$ A, 1/8-Unit-Load, Slew-Rate-Limited RS-485 Transceivers

Test Circuits

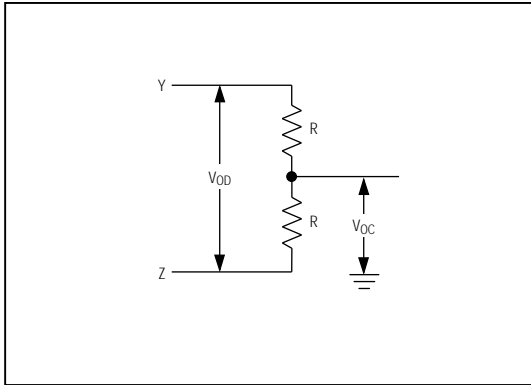

Figure 1. Driver DC Test Load

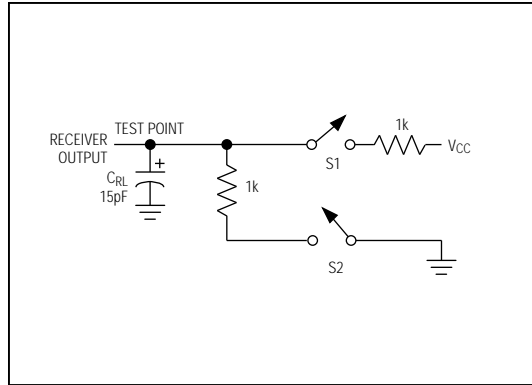

Figure 2. Receiver Timing Test Load

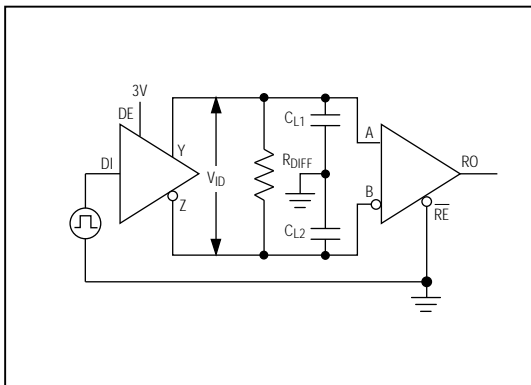

Figure 3. Driver/Receiver Timing Test Circuit

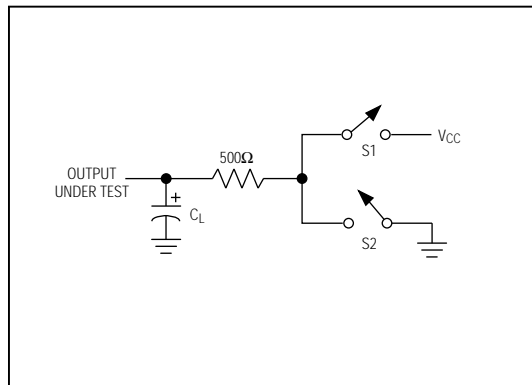

Figure 4. Driver Timing Test Load

# 20 $\mu$ A, 1/8-Unit-Load, Slew-Rate-Limited RS-485 Transceivers

## Switching Waveforms

MAX1482/MAX1483

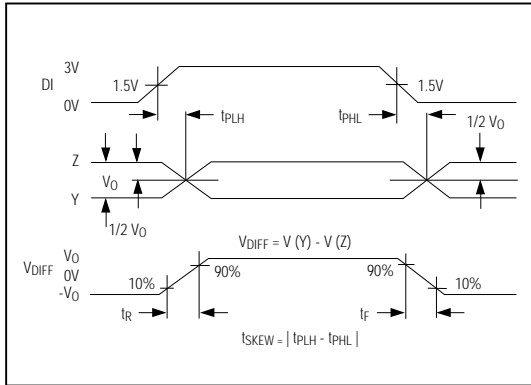

Figure 5. Driver Propagation Delays

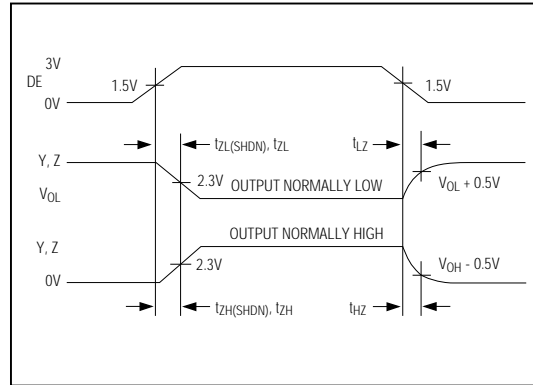

Figure 6. Driver Enable and Disable Times

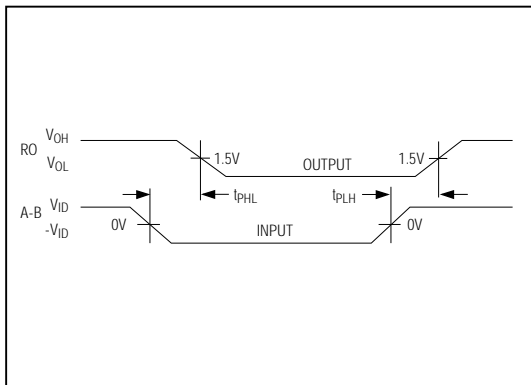

Figure 7. Receiver Propagation Delays

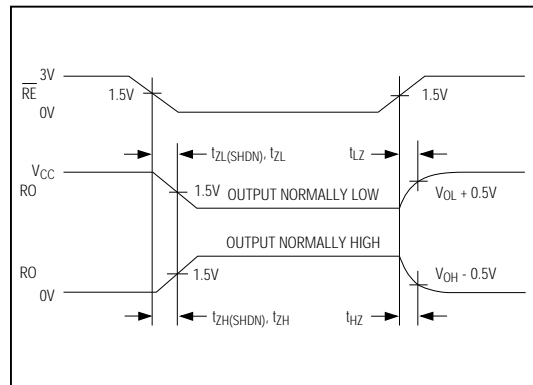

Figure 8. Receiver Enable and Disable Times

## 20μA, 1/8-Unit-Load, Slew-Rate-Limited RS-485 Transceivers

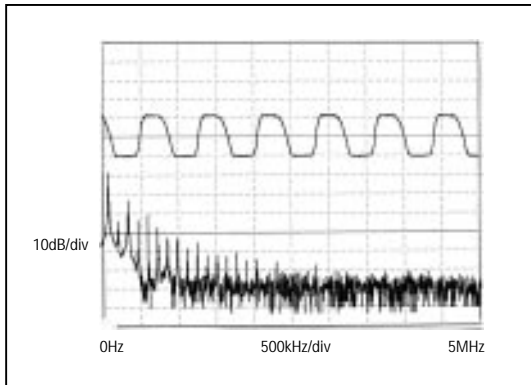

Figure 9. Driver Output Waveform and FFT, Transmitting 250kbps (125kHz) Signal

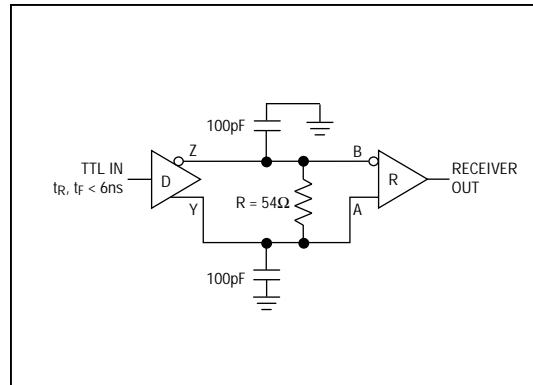

Figure 10. Receiver Propagation-Delay Test Circuit

**Table 1. Transmitting**

INPUTS			OUTPUTS	
$\overline{RE}$	DE	DI	Z	Y
X	1	1	0	1
X	1	0	1	0
X	0	X	High-Z	High-Z

X = Don't Care  
High-Z = High Impedance

**Table 2. Receiving**

INPUTS			OUTPUT
$\overline{RE}$	DE*	A-B	RO
0	0	$\geq +0.2V$	1
0	0	$\leq -0.2V$	0
0	0	Inputs open	1
1	0	X	High-Z

X = Don't Care  
High-Z = High Impedance  
\* DE = 0 for MAX1483 and is a Don't Care for MAX1482.

### Applications Information

The MAX1482/MAX1483 are low-power transceivers for RS-485 and RS-422 communications. The MAX1482 and MAX1483 are specified for data rates of at least 250kbps. The MAX1482 is a full-duplex transceiver while the MAX1483 is half duplex. When disabled, the driver and receiver outputs are high impedance.

The 96kΩ, 1/8-unit-load receiver input impedance of the MAX1482/MAX1483 allows up to 256 transceivers on a bus, compared to the 1-unit load (12kΩ input impedance) of standard RS-485 drivers (32 transceivers maximum). Any combination of MAX1482/MAX1483 and other RS-485 transceivers with a total of 32 unit loads or less can be put on the bus.

### Reduced EMI and Reflections

The MAX1482/MAX1483 are slew-rate limited, minimizing EMI and reducing reflections caused by improperly terminated cables. Figure 9 shows both the driver output waveform of a MAX1482/MAX1483 transmitting a 125kHz signal and the Fourier analysis of that signal.

High-frequency harmonics have much lower amplitudes, and the potential for EMI is significantly reduced.



## 20 $\mu$ A, 1/8-Unit-Load, Slew-Rate-Limited RS-485 Transceivers

MAX1482/MAX1483

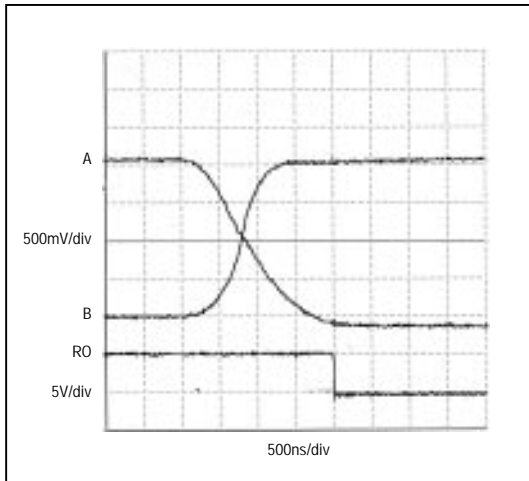

Figure 11. Receiver  $t_{PHL}$

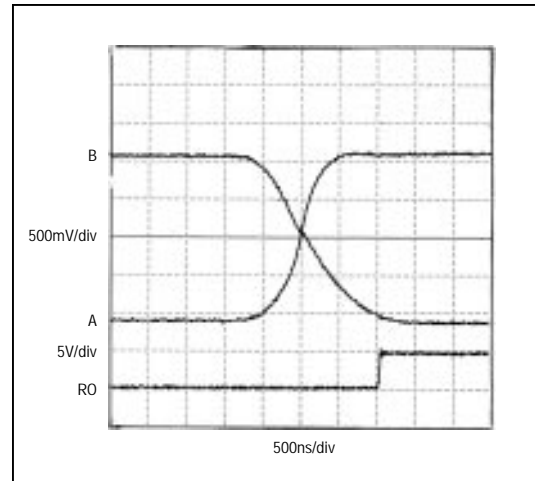

Figure 12. Receiver  $t_{PLH}$

### Low-Power Shutdown Mode

A low-power shutdown mode is initiated by bringing  $\overline{RE}$  high and DE low. The devices will not shut down unless **both** the driver and receiver are disabled. In shutdown, the devices typically draw only 0.1 $\mu$ A of supply current.

$\overline{RE}$  and DE may be driven simultaneously; the parts are guaranteed not to enter shutdown if  $\overline{RE}$  is high and DE is low for less than 50ns. If the inputs are in this state for at least 600ns, the parts are guaranteed to enter shutdown.

For the receiver, the  $t_{ZH}$  and  $t_{ZL}$  enable times assume the part was not in the low-power shutdown state. The  $t_{ZH}(SHDN)$  and  $t_{ZL}(SHDN)$  enable times assume the parts were shut down (see *Electrical Characteristics*).

It takes the receivers longer to become enabled from the low-power shutdown state ( $t_{ZH}(SHDN)$ ,  $t_{ZL}(SHDN)$ ) than from the operating mode ( $t_{ZH}$ ,  $t_{ZL}$ ). (The parts are in operating mode if the  $\overline{RE}$ , DE inputs equal a logical 0,1 or 1,1 or 0,0.)

### Driver Output Protection

Excessive output current and power dissipation caused by faults or by bus contention are prevented by two mechanisms. A foldback current limit on the output stage provides immediate protection against short circuits over the whole common-mode voltage range (see *Typical Operating Characteristics*). In addition, a thermal shutdown circuit forces the driver outputs into a high-impedance state if the die temperature rises excessively.

### Propagation Delay

Digital encoding schemes depend on the driver and receiver skew. Skew is defined as the difference between the rising and falling propagation delay times. Typical propagation delays are shown in Figures 11 and 12 using Figure 10's test circuit.

The difference in receiver delay times,  $|t_{PLH} - t_{PHL}|$ , is typically under 160ns.

The driver skew times are typically 160ns (800ns max).

## 20 $\mu$ A, 1/8-Unit-Load, Slew-Rate-Limited RS-485 Transceivers

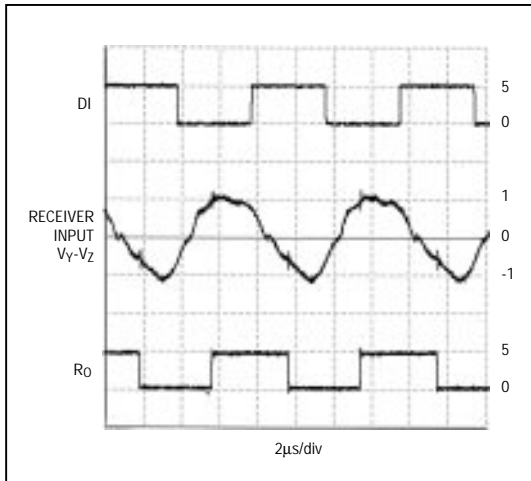

Figure 13. System Differential Voltage at 250kbps (125kHz) Driving 4000 Feet of Cable

### Line Length vs. Data Rate

The RS-485/RS-422 standard covers line lengths up to 4000 feet. For line lengths greater than 4000 feet, see Figure 16.

Figure 13 shows the system differential voltage for the parts driving 4000 feet of 26AWG twisted-pair wire at 110kHz into 120 $\Omega$  loads. Even after 4000 feet of cable, the MAX1482/MAX1483 output shows virtually no distortion.

### Typical Applications

The MAX1482/MAX1483 transceivers are designed for bidirectional data communications on multipoint bus transmission lines. Figures 14 and 15 show typical network applications circuits. These parts can also be used as line repeaters, with cable lengths longer than 4000 feet, as shown in Figure 16.

To minimize reflections, the line should be terminated at both ends in its characteristic impedance, and stub lengths off the main line should be kept as short as possible (although the slew-rate-limited MAX1482 and MAX1483 are more tolerant of imperfect termination than standard RS-485 ICs).

### Isolated RS-485

For isolated RS-485 applications, see the MAX253 and MAX1480 data sheets.

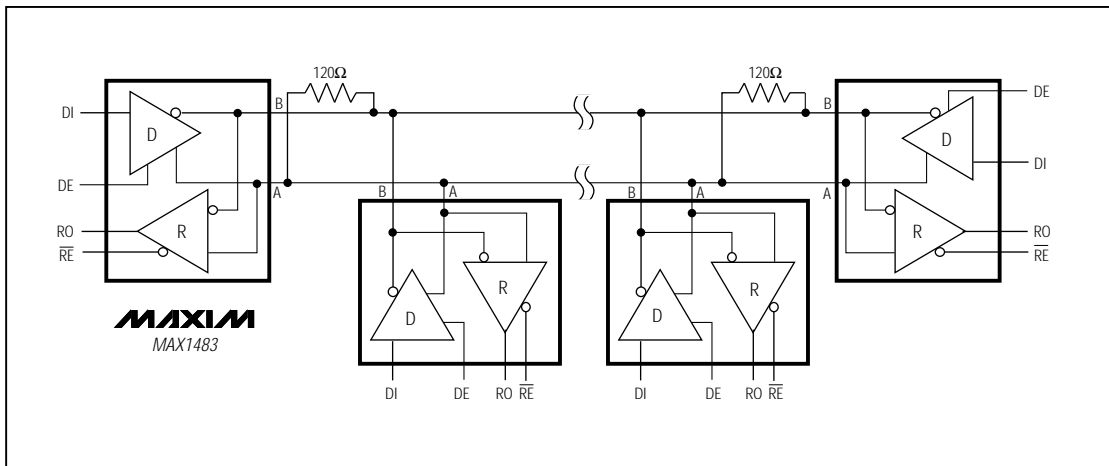

Figure 14. MAX1483 Typical Half-Duplex RS-485 Network

## 20 $\mu$ A, 1/8-Unit-Load, Slew-Rate-Limited RS-485 Transceivers

MAX1482/MAX1483

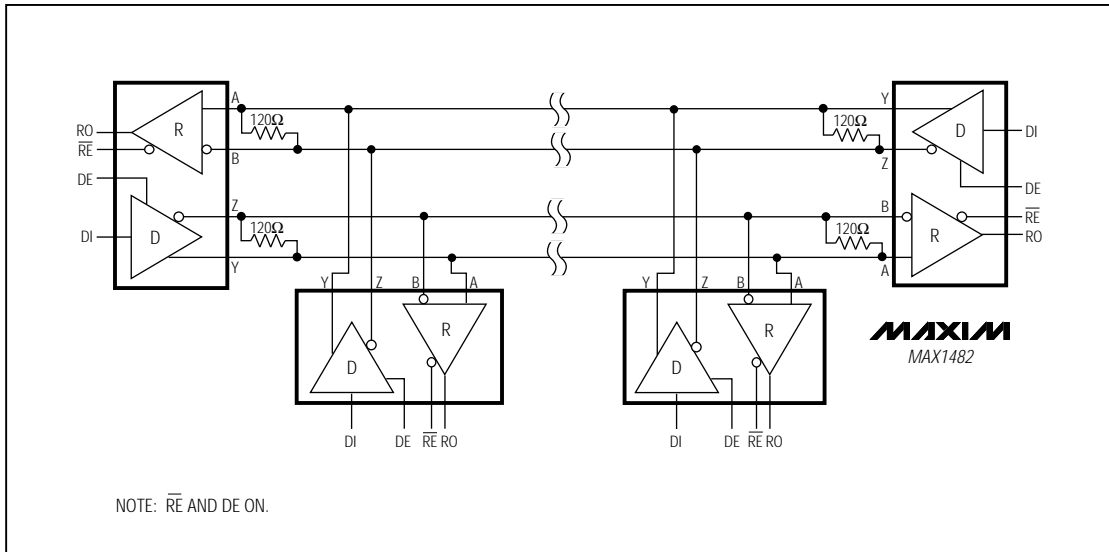

Figure 15. MAX1482 Full-Duplex RS-485 Network

### Typical Operating Circuits (continued)

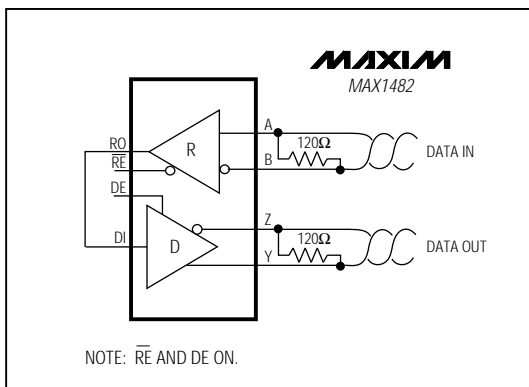
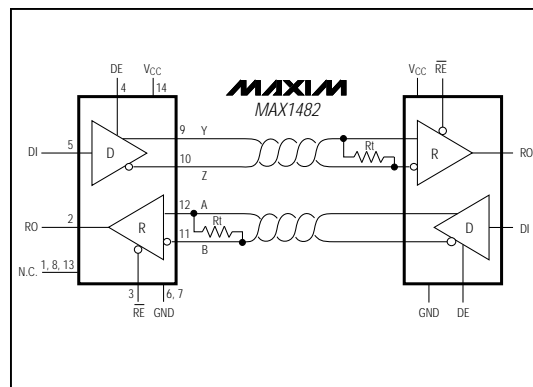

Figure 16. Line Repeater for MAX1482



# 20 $\mu$ A, 1/8-Unit-Load, Slew-Rate-Limited RS-485 Transceivers

Pin Configurations (continued)

Chip Information

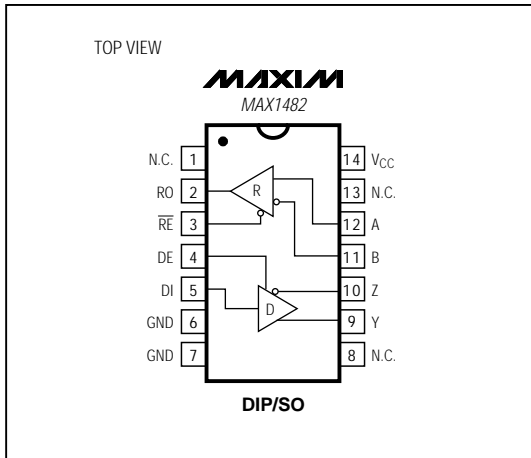

TRANSISTOR COUNT: 294

Package Information

DIM	INCHES		MILLIMETERS	
	MIN	MAX	MIN	MAX
A	0.036	0.044	0.91	1.11
A1	0.004	0.008	0.10	0.20
B	0.010	0.014	0.25	0.36
C	0.005	0.007	0.13	0.18
D	0.116	0.120	2.95	3.05
E	0.116	0.120	2.95	3.05
e	0.0256		0.65	
H	0.188	0.198	4.78	5.03
L	0.016	0.026	0.41	0.66
α	0°	6°	0°	6°

**8-PIN  $\mu$ MAX  
MICROMAX SMALL OUTLINE  
PACKAGE**

Maxim cannot assume responsibility for use of any circuitry other than circuitry entirely embodied in a Maxim product. No circuit patent licenses are implied. Maxim reserves the right to change the circuitry and specifications without notice at any time.

12 Maxim Integrated Products, 120 San Gabriel Drive, Sunnyvale, CA 94086 (408) 737-7600

© 1995 Maxim Integrated Products

Printed USA

MAXIM is a registered trademark of Maxim Integrated Products.