

## FEATURES

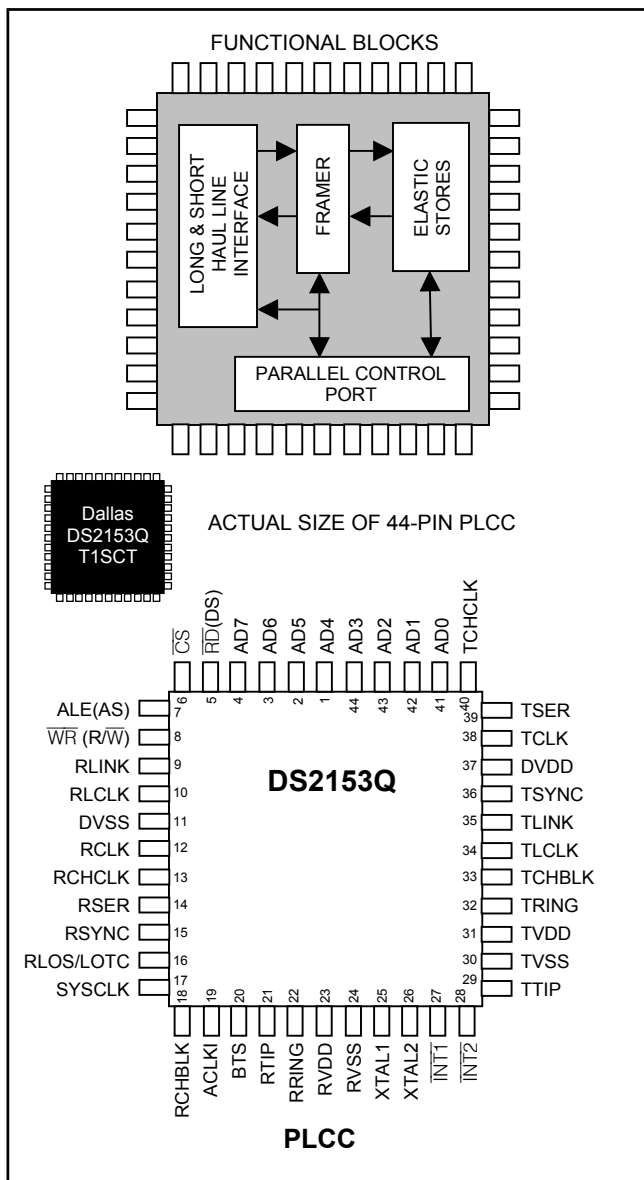
- Complete E1 (CEPT) PCM-30/ISDN-PRI Transceiver Functionality
- On-Board Line Interface for Clock/Data Recovery and Waveshaping
- 32-Bit or 128-Bit Jitter Attenuator
- Generates Line Build-Outs for Both 120Ω and 75Ω Lines
- Frames to FAS, CAS, and CRC4 Formats
- Dual On-Board Two-Frame Elastic Store Slip Buffers That can Connect to Backplanes Up to 8.192MHz
- 8-Bit Parallel Control Port That can be Used on Either Multiplexed or Nonmultiplexed Buses
- Extracts and Inserts CAS Signaling
- Detects and Generates Remote and AIS Alarms
- Programmable Output Clocks for Fractional E1, H0, and H12 Applications
- Fully Independent Transmit and Receive Functionality
- Full Access to Both Si and Sa Bits
- Three Separate Loopbacks for Testing
- Large Counters for Bipolar and Code Violations, CRC4 Codeword Errors, FAS Errors, and E Bits
- Pin Compatible with DS2151Q T1 Single-Chip Transceiver
- 5V Supply; Low-Power CMOS

## ORDERING INFORMATION

PART	TEMP RANGE	PIN-PACKAGE
DS2153Q	0°C to +70°C	44 PLCC
DS2153Q+	0°C to +70°C	44 PLCC
DS2153QN	-40°C to +85°C	44 PLCC
DS2153QN+	-40°C to +85°C	44 PLCC

+Denotes lead-free/RoHS-compliant package.

## PIN CONFIGURATION



**Note:** Some revisions of this device may incorporate deviations from published specifications known as errata. Multiple revisions of any device may be simultaneously available through various sales channels. For information about device errata, click here: [www.maxim-ic.com/errata](http://www.maxim-ic.com/errata).

## TABLE OF CONTENTS

<b>1</b>	<b>DETAILED DESCRIPTION</b>	<b>4</b>
1.1	INTRODUCTION	4
1.2	READER'S NOTE	4
<b>2</b>	<b>PIN DESCRIPTION</b>	<b>6</b>
2.1	DS2153Q REGISTER MAP	8
<b>3</b>	<b>PARALLEL PORT</b>	<b>9</b>
<b>4</b>	<b>CONTROL AND TEST REGISTERS</b>	<b>10</b>
4.1	LOCAL LOOPBACK	17
4.2	REMOTE LOOPBACK	17
4.3	FRAMER LOOPBACK	17
4.4	AUTOMATIC ALARM GENERATION	17
4.5	POWER-UP SEQUENCE	17
<b>5</b>	<b>STATUS AND INFORMATION REGISTERS</b>	<b>18</b>
5.1	CRC4 SYNC COUNTER	20
<b>6</b>	<b>ERROR COUNT REGISTERS</b>	<b>26</b>
6.1	BPV OR CODE VIOLATION COUNTER	26
6.2	CRC4 ERROR COUNTER	27
6.3	E-BIT COUNTER	27
6.4	FAS BIT ERROR COUNTER	28
<b>7</b>	<b>SA DATA LINK CONTROL AND OPERATION</b>	<b>29</b>
<b>8</b>	<b>SIGNALING OPERATION</b>	<b>30</b>
<b>9</b>	<b>TRANSMIT IDLE REGISTERS</b>	<b>32</b>
<b>10</b>	<b>CLOCK BLOCKING REGISTERS</b>	<b>33</b>
<b>11</b>	<b>ELASTIC STORES OPERATION</b>	<b>35</b>
<b>12</b>	<b>ADDITIONAL (SA) AND INTERNATIONAL (SI) BIT OPERATION</b>	<b>36</b>
<b>13</b>	<b>LINE INTERFACE FUNCTIONS</b>	<b>39</b>
13.1	RECEIVE CLOCK AND DATA RECOVERY	40
13.2	TRANSMIT WAVESHAPING AND LINE DRIVING	41
13.3	JITTER ATTENUATOR	42
<b>14</b>	<b>TIMING DIAGRAMS</b>	<b>46</b>
<b>15</b>	<b>DC CHARACTERISTICS</b>	<b>52</b>
<b>16</b>	<b>AC CHARACTERISTICS</b>	<b>53</b>
<b>17</b>	<b>PACKAGE INFORMATION</b>	<b>60</b>
17.1	44-PIN PLCC (56-G4003-001)	60

## LIST OF FIGURES

Figure 1-1. DS2153Q Block Diagram .....	5
Figure 13-1. External Analog Connections .....	43
Figure 13-2. Jitter Tolerance .....	44
Figure 13-3. Transmit Waveform Template .....	44
Figure 13-4. Jitter Attenuation .....	45
Figure 14-1. Receive Side Timing .....	46
Figure 14-2. Receive Side Boundary Timing (with Elastic Stores Disabled) .....	46
Figure 14-3. 1.544MHz Boundary Timing with Elastic Store(s) Disabled .....	47
Figure 14-4. 2.048MHz Boundary Timing with Elastic Store(s) Enabled .....	47
Figure 14-5. Transmit Side Timing .....	48
Figure 14-6. Transmit Side Boundary Timing .....	48
Figure 14-7. G.802 Timing.....	49
Figure 14-8. Synchronization Flowchart .....	50
Figure 14-9. Transmit Data Flow .....	51
Figure 16-1. Intel Bus Read AC Timing .....	54
Figure 16-2. Intel Bus Write AC Timing .....	54
Figure 16-3. Motorola Bus AC Timing .....	55
Figure 16-4. Receive Side AC Timing .....	57
Figure 16-5. Transmit Side AC Timing .....	59

## LIST OF TABLES

Table 4-1. Sync/Resync Criteria .....	11
Table 5-1. Alarm Set and Clear Criteria .....	22
Table 13-1. Source of RCLK Upon RCL .....	40
Table 13-2. LBO Select in LICR .....	41
Table 13-3. Transformer Specifications .....	41
Table 13-4. Crystal Selection Guidelines .....	42
Table 15-1. Recommended DC Characteristics .....	52
Table 15-2. Capacitance .....	52
Table 15-3. DC Characteristics .....	52
Table 16-1. AC Characteristics—Parallel Port .....	53
Table 16-2. AC Characteristics—Receive Side .....	56
Table 16-3. AC Characteristics—Transmit Side .....	58

## 1 DETAILED DESCRIPTION

The DS2153Q E1 single-chip transceiver (SCT) contains all the necessary functions for connection to E1 lines. The on-board clock/data recovery circuitry converts the AMI/HDB3 E1 waveforms to a NRZ serial stream. The DS2153Q automatically adjusts to E1 22 AWG (0.6mm) twisted-pair cables from 0 to 1.5km. The device can generate the necessary G.703 waveshapes for both 75 $\Omega$  and 120 $\Omega$  cables. The on-board jitter attenuator (selectable to either 32 bits or 128 bits) can be placed in either the transmit or receive data paths. The framer locates the frame and multiframe boundaries and monitors the data stream for alarms. It is also used for extracting and inserting signaling data, Si, and Sa-bit information. The device contains a set of 71 8-bit internal registers that the user can access to control the operation of the unit. Quick access via the parallel control port allows a single micro to handle many E1 lines. The device fully meets all the latest E1 specifications, including ITU G.703, G.704, G.706, G.823, and I.431 as well as ETSI 300 011, 300 233, TBR 12 and TBR 13.

### 1.1 Introduction

The analog AMI waveform off of the E1 line is transformer coupled into the RRING and RTIP pins of the DS2153Q. The device recovers clock and data from the analog signal and passes it through the jitter attenuation mux to the receive side framer where the digital serial stream is analyzed to locate the framing pattern. If needed, the receive side elastic store can be enabled in order to absorb the phase and frequency differences between the recovered E1 data stream and an asynchronous backplane clock which is provided at the SYSCLK input.

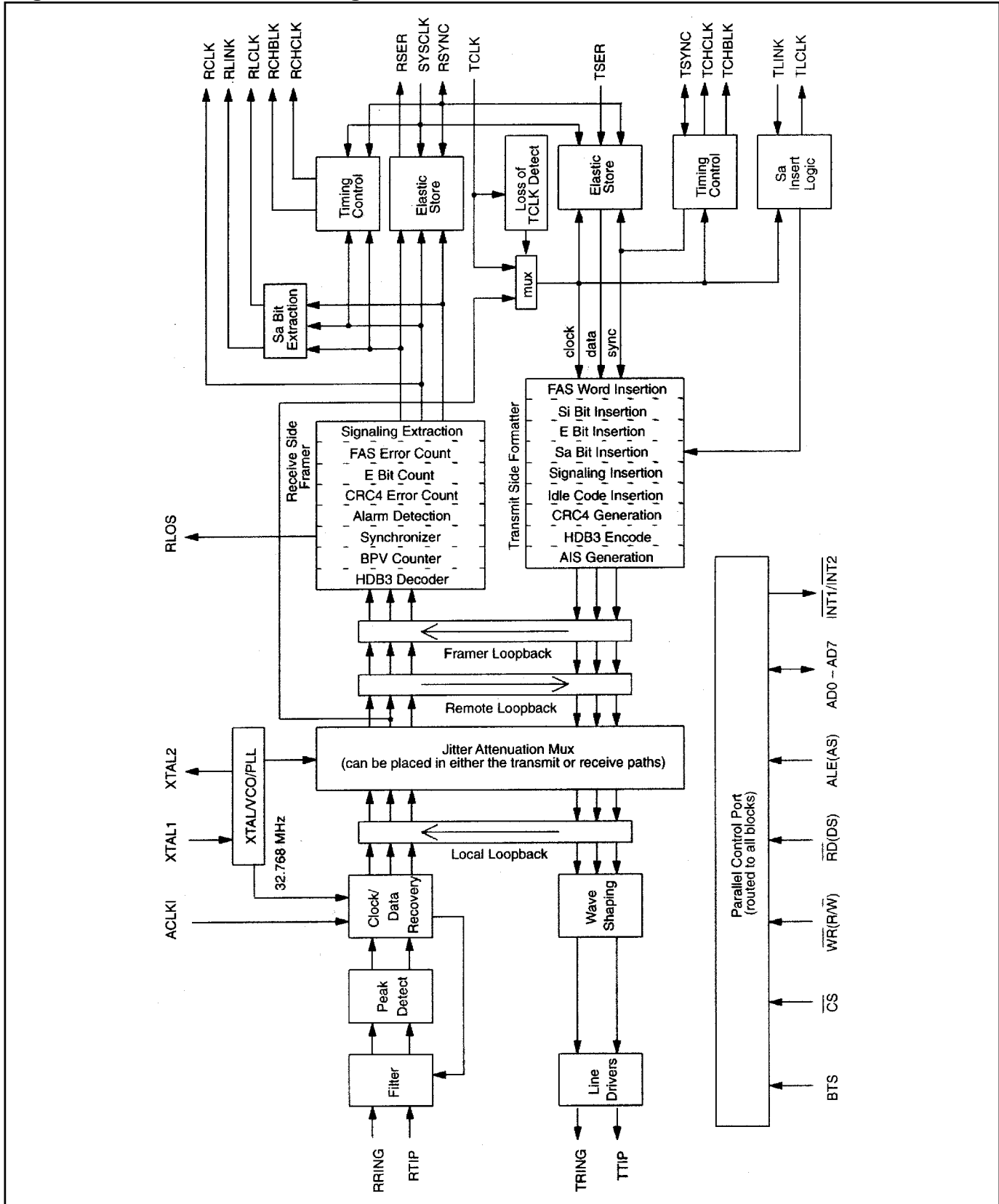
The transmit side of the DS2153Q is totally independent from the receive side in both the clock requirements and characteristics. The transmit formatter will provide the necessary data overhead for E1 transmission. Once the data stream has been prepared for transmission, it is sent via the jitter attenuation mux to the waveshaping and line driver functions. The DS2153Q will drive the E1 line from the TTIP and TRING pins via a coupling transformer.

### 1.2 Reader's Note

This data sheet assumes a particular nomenclature of the E1 operating environment. There are 32 8-bit time slots in E1 systems that are numbered 0 to 31. Time slot 0 is transmitted first and received first. These 32 time slots are also referred to as channels with a numbering scheme of 1 to 32. Time slot 0 is identical to channel 1, time slot 1 is identical to channel 2, and so on. Each time slot (or channel) is made up of 8 bits numbered 1 to 8. Bit number 1 is the MSB and is transmitted first. Bit number 8 is the LSB and is transmitted last. Throughout this data sheet, the following abbreviations are used:

FAS	Frame Alignment Signal
CAS	Channel Associated Signaling
MF	Multiframe
Si	International Bits
CRC4	Cyclical Redundancy Check
CCS	Common Channel Signaling
Sa	Additional bits
E-bit	CRC4 Error bits

Figure 1-1. DS2153Q Block Diagram



## 2 PIN DESCRIPTION

PIN	NAME	TYPE	FUNCTION
1–4, 41–44	AD4–AD7, AD0–AD3	I/O	<b>Address/Data Bus.</b> An 8-bit multiplexed address/data bus.
5	$\overline{\text{RD}}$ (DS)	I	<b>Active-Low Read Input (Data Strobe)</b>
6	$\overline{\text{CS}}$	I	<b>Active-Low Chip Select.</b> Must be low to read or write the port.
7	ALE(AS)	I	<b>Address Latch Enable (Address Strobe).</b> A positive going edge serves to demultiplex the bus.
8	$\overline{\text{WR}}$ (R/ $\overline{\text{W}}$ )	I	<b>Active-Low Write Input (Read/Write)</b>
9	RLINK	O	<b>Receive Link Data.</b> Outputs the full receive data stream including the Sa bits. See Section 14 for timing details.
10	RLCLK	O	<b>Receive Link Clock.</b> 4kHz to 20kHz demand clock for the RLINK output. Controlled by RCR2. See Section 14 for timing details.
11	DVSS	—	<b>Digital Signal Ground.</b> 0.0V. Should be tied to local ground plane.
12	RCLK	O	<b>Receive Clock.</b> Recovered 2.048MHz clock.
13	RCHCLK	O	<b>Receive Channel Clock.</b> 256kHz clock that pulses high during the LSB of each channel. Useful for parallel to serial conversion of channel data. See Section 14 for timing details.
14	RSER	O	<b>Receive Serial Data.</b> Received NRZ serial data, updated on rising edges of RCLK or SYSCLK.
15	RSYNC	I/O	<b>Receive Sync.</b> An extracted pulse, one RCLK wide, is output at this pin, which identifies either frame (RCR1.6 = 0) or multiframe boundaries (RCR1.6 = 1). If the elastic store is enabled via the RCR2.1, then this pin can be enabled to be an input via RCR1.5 at which a frame boundary pulse is applied. See Section 14 for timing details.
16	RLOS/LOTCL	O	<b>Receive Loss of Sync/Loss of Transmit Clock.</b> A dual function output. If TCR2.0 = 0, will toggle high when the synchronizer is searching for the E1 frame and multiframe; if TCR2.0 = 1, will toggle high if the TCLK pin has not toggled for 5 $\mu$ s.
17	SYSCLK	I	<b>System Clock.</b> 1.544MHz or 2.048MHz clock. Only used when the elastic store functions are enabled via either RCR2.1. Should be tied low in applications that do not use the elastic store. If tied high for at least 100 $\mu$ s, will force all output pins (including the parallel port) to tri-state.
18	RCHBLK	O	<b>Receive Channel Block.</b> A user-programmable output that can be forced high or low during any of the 32 E1 channels. Useful for blocking clocks to a serial UART or LAPD controller in applications where not all E1 channels are used such as Fractional E1, 384kbps service (H0), 1920kbps (H12), or ISDN-PRI. Also useful for locating individual channels in drop-and-insert applications. See Section 14 for timing details.
19	ACLKI	I	<b>Alternate Clock Input.</b> Upon a receive carrier loss, the clock applied at this pin (normally 2.048MHz) will be routed to the RCLK pin. If no clock is routed to this pin, then it should be tied to DVSS via a 1k $\Omega$ resistor.

PIN	NAME	TYPE	FUNCTION
20	BTS	I	<b>Bus Type Select.</b> Strap high to select Motorola bus timing; strap low to select Intel bus timing. This pin controls the function of the RD (DS), ALE(AS), and $\overline{WR}$ (R/ $\overline{W}$ ) pins. If BTS = 1, then these pins assume the function listed in parentheses ().
21, 22	RTIP, RRING	—	<b>Receive Tip and Ring.</b> Analog inputs for clock recovery circuitry; connects to a 1:1 transformer (see Section 13 for details).
23	RVDD	—	<b>Receive Analog Positive Supply.</b> 5.0V. Should be tied to DVDD and TVDD pins.
24	RVSS	—	<b>Receive Signal Ground.</b> 0V. Should be tied to local ground plane.
25, 26	XTAL1, XTAL2	—	<b>Crystal Connections.</b> A pullable 8.192MHz crystal must be applied to these pins. See Section 13 for crystal specifications.
27	$\overline{INT1}$	O	<b>Receive Alarm Interrupt 1.</b> Flags host controller during alarm conditions defined in Status Register 1. Active low, open drain output.
28	$\overline{INT2}$	O	<b>Receive Alarm Interrupt 2.</b> Flags host controller during conditions defined in Status Register 2. Active low, open drain output.
29	TTIP	—	<b>Transmit Tip.</b> Analog line driver output; connects to a step-up transformer (see Section 13 for details).
30	TVSS	—	<b>Transmit Signal Ground.</b> 0V. Should be tied to local ground plane.
31	TVDD	—	<b>Transmit Analog Positive Supply.</b> 5.0V. Should be tied to DVDD and RVDD pins.
32	TRING	—	<b>Transmit Ring.</b> Analog line driver outputs; connects to a step-up transformer (see Section 13 for details).
33	TCHBLK	O	<b>Transmit Channel Block.</b> A user-programmable output that can be forced high or low during any of the 32 E1 channels. Useful for blocking clocks to a serial UART or LAPD controller in applications where not all E1 channels are used such as Fractional E1, 384kbps service (H0), 1920kbps (H12), or ISDN-PRI. Also useful for locating individual channels in drop-and-insert applications. See Section 14 for timing details.
34	TLCLK	O	<b>Transmit Link Clock.</b> 4kHz to 20kHz demand clock for the TLINK input. Controlled by TCR2. See Section 14 for timing details.
35	TLINK	I	<b>Transmit Link Data.</b> If enabled, this pin will be sampled on the falling edge of TCLK to insert the Sa bits. See Section 14 for timing details.
36	TSYNC	I/O	<b>Transmit Sync.</b> A pulse at this pin will establish either frame or multiframe boundaries for the DS2153Q. Via TCR1.1, the DS2153Q can be programmed to output either a frame or multiframe pulse at this pin. See Section 14 for timing details.
37	DVDD	—	<b>Digital Positive Supply.</b> 5.0V. Should be tied to RVDD and TVDD pins.
38	TCLK	I	<b>Transmit Clock.</b> 2.048MHz primary clock.
39	TSER	I	<b>Transmit Serial Data.</b> Transmit NRZ serial data, sampled on the falling edge of TCLK.
40	TCHCLK	O	<b>Transmit Channel Clock.</b> 256kHz clock that pulses high during the LSB of each channel. Useful for parallel to serial conversion of channel data. See Section 14 for timing details.

## 2.1 DS2153Q Register Map

ADDRESS	R/W	REGISTER NAME	ADDRESS	R/W	REGISTER NAME
00	R	BPV or Code Violation Count 1	20	R/W	Transmit Align Frame
01	R	BPV or Code Violation Count 2	21	R/W	Transmit Non-Align Frame
02	R	CRC4 Count 1/FAS Error Count 1	22	R/W	Transmit Channel Blocking 1
03	R	CRC4 Error Count 2	23	R/W	Transmit Channel Blocking 2
04	R	E-Bit Count 1/FAS Error Count 2	24	R/W	Transmit Channel Blocking 3
05	R	E-Bit Count 2	25	R/W	Transmit Channel Blocking 4
06	R	Status 1	26	R/W	Transmit Idle 1
07	R	Status 2	27	R/W	Transmit Idle 2
08	R/W	Receive Information	28	R/W	Transmit Idle 3
10	R/W	Receive Control 1	29	R/W	Transmit Idle 4
11	R/W	Receive Control 2	2A	R/W	Transmit Idle Definition
12	R/W	Transmit Control 1	2B	R/W	Receive Channel Blocking 1
13	R/W	Transmit Control 2	2C	R/W	Receive Channel Blocking 2
14	R/W	Common Control 1	2E	R/W	Receive Channel Blocking 3
15	R/W	Test 1	2E	R/W	Receive Channel Blocking 4
16	R/W	Interrupt Mask 1	2F	R	Receive Align Frame
17	R/W	Interrupt Mask 2	30	R	Receive Signaling 1
18	R/W	Line Interface Control	31	R	Receive Signaling 2
19	R/W	Test 2	32	R	Receive Signaling 3
1A	R/W	Common Control 2	33	R	Receive Signaling 4
1B	R/W	Common Control 3	34	R	Receive Signaling 5
1E	R	Synchronizer Status	35	R	Receive Signaling 6
1F	R	Receive Non-Align Frame	36	R	Receive Signaling 7
40	R/W	Transmit Signaling 1	37	R	Receive Signaling 8
41	R/W	Transmit Signaling 2	38	R	Receive Signaling 9
42	R/W	Transmit Signaling 3	39	R	Receive Signaling 10
43	R/W	Transmit Signaling 4	3A	R	Receive Signaling 11
44	R/W	Transmit Signaling 5	3B	R	Receive Signaling 12
45	R/W	Transmit Signaling 6	3C	R	Receive Signaling 13
46	R/W	Transmit Signaling 7	3D	R	Receive Signaling 14
47	R/W	Transmit Signaling 8	3E	R	Receive Signaling 15
48	R/W	Transmit Signaling 9	3F	R	Receive Signaling 16
49	R/W	Transmit Signaling 10			
4A	R/W	Transmit Signaling 11			
4B	R/W	Transmit Signaling 12			
4C	R/W	Transmit Signaling 13			
4D	R/W	Transmit Signaling 14			
4E	R/W	Transmit Signaling 15			
4F	R/W	Transmit Signaling 16			

**Note:** Test Registers 1 and 2 are used only by the factory; these registers must be cleared (set to all 0s) on power-up initialization to ensure proper operation.



### 3 PARALLEL PORT

The DS2153Q is controlled via a multiplexed bidirectional address/data bus by an external microcontroller or microprocessor. The DS2153Q can operate with either Intel or Motorola bus timing configurations. If the BTS pin is tied low, Intel timing will be selected; if tied high, Motorola timing will be selected. All Motorola bus signals are listed in parentheses (). See the timing diagrams in Section [14](#) for more details. The multiplexed bus on the DS2153Q saves pins because the address information and data information share the same signal paths. The addresses are presented to the pins in the first portion of the bus cycle and data will be transferred on the pins during second portion of the bus cycle. Addresses must be valid prior to the falling edge of ALE (AS), at which time the DS2153Q latches the address from the AD0 to AD7 pins. Valid write data must be present and held stable during the later portion of the DS or  $\overline{\text{WR}}$  pulses. In a read cycle, the DS2153Q outputs a byte of data during the latter portion of the DS or  $\overline{\text{RD}}$  pulses. The read cycle is terminated and the bus returns to a high-impedance state as  $\overline{\text{RD}}$  transitions high in Intel timing or as DS transitions low in Motorola timing.

## 4 CONTROL AND TEST REGISTERS

The operation of the DS2153Q is configured via a set of seven registers. Typically, the control registers are only accessed when the system is first powered up. Once the DS2153Q has been initialized, the control registers only need to be accessed when there is a change in the system configuration. There are two Receive Control Registers (RCR1 and RCR2), two Transmit Control Registers (TCR1 and TCR2), and three Common Control Registers (CCR1, CCR2, and CCR3). Each of the seven registers is described in this section. The LICR is described in Section [13](#).

The Test Registers at addresses 15 and 19 hex are used by the factory in testing the DS2153Q. On power-up, the Test Registers should be set to 00 hex in order for the DS2153Q to operate properly.

### RCR1: RECEIVE CONTROL REGISTER 1 (Address = 10B Hex)

(MSB)				(LSB)			
RSMF	RSM	RSIO	—	—	FRC	SYNCE	RESYNC

SYMBOL	POSITION	NAME AND DESCRIPTION
RSMF	RCR1.7	<b>RSYNC Multiframe Function.</b> Only used if the RSYNC pin is programmed in the multiframe mode (RCR1.6 = 1). 0 = RSYNC outputs CAS multiframe boundaries 1 = RSYNC outputs CRC4 multiframe boundaries
RSM	RCR1.6	<b>RSYNC Mode Select.</b> 0 = frame mode (see the timing in Section <a href="#">14</a> ) 1 = multiframe mode (see the timing in Section <a href="#">14</a> )
RSIO	RCR1.5	<b>RSYNC I/O Select.</b> 0 = RSYNC is an output (depends on RCR1.6) 1 = RSYNC is an input (only valid if elastic store enabled) (Note: this bit must be set to 0 when RCR2.1 = 0)
—	RCR1.4	<b>Not Assigned.</b> Should be set to 0 when written.
—	RCR1.3	<b>Not Assigned.</b> Should be set to 0 when written.
FRC	RCR1.2	<b>Frame Resync Criteria.</b> 0 = resync if FAS received in error 3 consecutive times 1 = resync if FAS or bit 2 of non-FAS is received in error 3 consecutive times
SYNCE	RCR1.1	<b>Sync Enable.</b> 0 = auto resync enabled 1 = auto resync disabled
RESYNC	RCR1.0	<b>Resync.</b> When toggled from low to high, a resync is initiated. Must be cleared and set again for a subsequent resync.

**Table 4-1. Sync/Resync Criteria**

FRAME OR MULTIFRAME LEVEL	SYNC CRITERIA	RESYNC CRITERIA	ITU SPEC
FAS	FAS present in frames N and N + 2, and FAS not present in frame N + 1.	Three consecutive incorrect FAS received. Alternate (RCR1.2 = 1) the above criteria is met or three consecutive incorrect bit 2 of non-FAS received.	G.706 4.1.1 4.1.2
CRC4	Two valid MF alignment words found within 8ms.	915 or more CRC4 codewords out of 1000 received in error.	G.706 4.2 4.3.2
CAS	Valid MF alignment word found and previous time slot 16 contains code other than all 0s.	Two consecutive MF alignment words received in error.	G.732 5.2

**RCR2: RECEIVE CONTROL REGISTER 2 (Address = 11 Hex)**

(MSB)							(LSB)
Sa8S	Sa7S	Sa6S	Sa5S	Sa4S	RSCLKM	RESE	—

SYMBOL	POSITION	NAME AND DESCRIPTION
Sa8S	RCR2.7	<b>Sa8 Bit Select.</b> Set to 1 to report the Sa8 bit at the RLINK pin; set to 0 to not report the Sa8 bit.
Sa7S	RCR2.6	<b>Sa7 Bit Select.</b> Set to 1 to report the Sa7 bit at the RLINK pin; set to 0 to not report the Sa7 bit.
Sa6S	RCR2.5	<b>Sa6 Bit Select.</b> Set to 1 to report the Sa6 bit at the RLINK pin; set to 0 to not report the Sa6 bit.
Sa5S	RCR2.4	<b>Sa5 Bit Select.</b> Set to 1 to report the Sa5 bit at the RLINK pin; set to 0 to not report the Sa5 bit.
Sa4S	RCR2.3	<b>Sa4 Bit Select.</b> Set to 1 to report the Sa4 bit at the RLINK pin; set to 0 to not report the Sa4 bit.
RSCLKM	RCR2.2	<b>Receive Side SYSCLK Mode Select.</b> 0 = if SYSCLK is 1.544MHz 1 = if SYSCLK is 2.048MHz
RESE	RCR2.1	<b>Receive Side Elastic Store Enable.</b> 0=elastic store is bypassed 1=elastic store is enabled
—	RCR2.0	<b>Not Assigned.</b> Should be set to 0 when written.

**TCR1: TRANSMIT CONTROL REGISTER 1 (Address = 12 Hex)**

(MSB)							(LSB)
—	TFPT	T16S	TUA1	TSiS	TSA1	TSM	TSIO

SYMBOL	POSITION	NAME AND DESCRIPTION
—	TCR1.7	<b>Not Assigned.</b> Should be set to 0 when written to.
TFPT	TCR1.6	<b>Transmit Time Slot 0 Pass Through.</b> 0 = FAS bits/Sa bits/Remote Alarm sourced internally from the TAF and TNAF registers 1 = FAS bits/Sa bits/Remote Alarm sourced from TSER
T16S	TCR1.5	<b>Transmit Time Slot 16 Data Select.</b> 0 = sample time slot 16 at TSER pin 1 = source time slot 16 from TS1 to TS16 registers
TUA1	TCR1.4	<b>Transmit Unframed All Ones.</b> 0 = transmit data normally 1 = transmit an unframed all ones code at TPOS and TNEG
TSiS	TCR1.3	<b>Transmit International Bit Select.</b> 0 = sample Si bits at TSER pin 1 = source Si bits from TAF and TNAF registers (in this mode, TCR1.6 must be set to 0)
TSA1	TCR1.2	<b>Transmit Signaling All Ones.</b> 0 = normal operation 1 = force time slot 16 in every frame to all ones
TSM	TCR1.1	<b>TSYNC Mode Select.</b> 0 = frame mode (see the timing in Section <a href="#">14</a> ) 1 = CAS and CRC4 multiframe mode (see the timing in Section <a href="#">14</a> )
TSIO	TCR1.0	<b>TSYNC I/O Select.</b> 0 = TSYNC is an input 1 = TSYNC is an output

**Note:** For details about how the Transmit Control Registers affect the operation of the DS2153Q, see [Figure 14-9](#).

**TCR2: TRANSMIT CONTROL REGISTER 2 (Address = 13 Hex)**

(MSB)						(LSB)	
Sa8S	Sa7S	Sa6S	Sa5S	Sa4S	—	AEBE	P16F

SYMBOL	POSITION	NAME AND DESCRIPTION
Sa8S	TCR2.7	<b>Sa8 Bit Select.</b> Set to 1 to source the Sa8 bit from the TLINK pin; set to 0 to not source the Sa8 bit.
Sa7S	TCR2.6	<b>Sa7 Bit Select.</b> Set to 1 to source the Sa7 bit from the TLINK pin; set to 0 to not source the Sa7 bit.
Sa6S	TCR2.5	<b>Sa6 Bit Select.</b> Set to 1 to source the Sa6 bit from the TLINK pin; set to 0 to not source the Sa6 bit.
Sa5S	TCR2.4	<b>Sa5 Bit Select.</b> Set to 1 to source the Sa5 bit from the TLINK pin; set to 0 to not source the Sa5 bit.
Sa4S	TCR2.3	<b>Sa4 Bit Select.</b> Set to 1 to source the Sa4 bit from the TLINK pin; set to 0 to not source the Sa4 bit.
—	TCR2.2	<b>Not Assigned.</b> Should be set to 0 when written.
AEBE	TCR2.1	<b>Automatic E-Bit Enable.</b> 0 = E-bits not automatically set in the transmit direction 1 = E-bits automatically set in the transmit direction
P16F	TCR2.0	<b>Function of Pin 16.</b> 0 = Receive Loss of Sync (RLOS) 1 = Loss of Transmit Clock (LOTIC)

**CCR1: COMMON CONTROL REGISTER 1 (Address = 14 Hex)**

(MSB)						(LSB)	
FLB	THDB3	TG802	TCRC4	RSM	RHDB3	RG802	RCRC4

SYMBOL	POSITION	NAME AND DESCRIPTION
FLB	CCR1.7	<b>Framer Loopback.</b> 0 = loopback disabled 1 = loopback enabled
THDB3	CCR1.6	<b>Transmit HDB3 Enable.</b> 0 = HDB3 disabled 1 = HDB3 enabled
TG802	CCR1.5	<b>Transmit G.802 Enable.</b> See <a href="#">Figure 14-7</a> for details. 0 = do not force TCHBLK high during bit 1 of time slot 26 1 = force TCHBLK high during bit 1 of time slot 26
TCRC4	CCR1.4	<b>Transmit CRC4 Enable.</b> 0 = CRC4 disabled 1 = CRC4 enabled
RSM	CCR1.3	<b>Receive Signaling Mode Select.</b> 0 = CAS signaling mode 1 = CCS signaling mode
RHDB3	CCR1.2	<b>Receive HDB3 Enable.</b> 0 = HDB3 disabled 1 = HDB3 enabled
RG802	CCR1.1	<b>Receive G.802 Enable.</b> See <a href="#">Figure 14-7</a> for details. 0 = do not force RCHBLK high during bit 1 of time slot 26 1 = force RCHBLK high during bit 1 of time slot 26
RCRC4	CCR1.0	<b>Receive CRC4 Enable.</b> 0 = CRC4 disabled 1 = CRC4 enabled

**CCR2: COMMON CONTROL REGISTER 2 (Address = 1A Hex)**

<b>(MSB)</b>						<b>(LSB)</b>	
ECUS	VCRFS	AAIS	ARA	RSERC	LOTCCM	RLB	LLB

SYMBOL	POSITION	NAME AND DESCRIPTION
ECUS	CCR2.7	<b>Error Counter Update Select.</b> 0 = update error counters once a second 1 = update error counters every 62.5ms (500 frames)
VCRFS	CCR2.6	<b>VCR Function Select.</b> 0 = count Bipolar Violations (BPVs) 1 = count Code Violations (CVs)
AAIS	CCR2.5	<b>Automatic AIS Generation.</b> 0 = disabled 1 = enabled
ARA	CCR2.4	<b>Automatic Remote Alarm Generation.</b> 0 = disabled 1 = enabled
RSERC	CCR2.3	<b>RSER Control.</b> 0 = allow RSER to output data as received under all conditions 1 = force RSER to 1 under loss of frame alignment conditions
LOTCCM	CCR2.2	<b>Loss of Transmit Clock Mux Control.</b> Determines whether the transmit side formatter should switch to the ever present RCLK if the TCLK should fail to transition (see <a href="#">Figure 1-1</a> ). 0 = do not switch to RCLK if TCLK stops 1 = switch to RCLK if TCLK stops
RLB	CCR2.1	<b>Remote Loopback.</b> 0 = loopback disabled 1 = loopback enabled
LLB	CCR2.0	<b>Local Loopback.</b> 0 = loopback disabled 1 = loopback enabled

**CCR3: COMMON CONTROL REGISTER 3 (Address = 1B Hex)**

(MSB)						(LSB)	
TESE	TCBFS	TIRFS	ESR	LIRST	—	TSCLKM	—

SYMBOL	POSITION	NAME AND DESCRIPTION
TESE	CCR3.7	<b>Transmit Elastic Store Enable.</b> 0 = elastic store is disabled 1 = elastic store is enabled
TCBFS	CCR3.6	<b>Transmit Channel Blocking Registers (TCBR) Function Select.</b> 0 = TCBRs define the operation of the TCHBLK output pin 1 = TCBRs define which signaling bits are to be inserted
TIRFS	CCR3.5	<b>Transmit Idle Registers (TIR) Function Select.</b> 0 = TIRs define in which channels to insert idle code 1 = TIRs define in which channels to insert data from RSER
ESR	CCR3.4	<b>Elastic Stores Reset.</b> Setting this bit from a 1 to a 0 will force the elastic stores to a known depth. Should be toggled after SYSCLK has been applied and is stable. Must be set and cleared again for a subsequent reset. Do not leave this bit set high.
LIRST	CCR3.3	<b>Line Interface Reset.</b> Setting this bit from a 0 to a 1 will initiate an internal reset that affects the slicer, AGC, clock recovery state machine, and jitter attenuator. Normally this bit is only toggled on power-up. Must be cleared and set again for a subsequent reset.
—	CCR3.2	<b>Not Assigned.</b> Should be set to 0 when written.
TSCLKM	CCR3.1	<b>Transmit Backplane Clock Select.</b> Must be set like RCR2.2. 0 = 1.544MHz 1 = 2.048MHz
—	CCR3.0	<b>Not Assigned.</b> Should be set to 0 when written.



## 4.1 Local Loopback

When CCR2.0 is set to a 1, the DS2153Q will be forced into Local Loopback (LLB). In this loopback, data will continue to be transmitted as normal through the transmit side of the SCT. Data being received at RTIP and RRING will be replaced with the data being transmitted. Data in this loopback will pass through the jitter attenuator. See [Figure 1-1](#) for more details.

## 4.2 Remote Loopback

When CCR2.1 is set to a 1, the DS2153Q will be forced into Remote Loopback (RLB). In this loopback, data recovered off the E1 line from the RTIP and RRING pins will be transmitted back onto the E1 line (with any BPVs that might have occurred intact) via the TTIP and TRING pins. Data will continue to pass through the receive side of the DS2153Q as it would normally and the data at the TSER input will be ignored. Data in this loopback will pass through the jitter attenuator. See [Figure 1-1](#) for more details.

## 4.3 Framer Loopback

When CCR1.7 is set to a 1, the DS2153Q will enter a Framer Loopback (FLB) mode. This loopback is useful in testing and debugging applications. In FLB, the DS2153Q will loop data from the transmit side back to the receive side. When FLB is enabled, the following will occur:

- 1) Data will be transmitted at TTIP and TRING.
- 2) Data off the E1 line at RTIP and RRING will be ignored.

The RCLK output will be replaced with the TCLK input.

## 4.4 Automatic Alarm Generation

When either CCR2.4 or CCR2.5 is set to 1, the DS2153Q monitors the receive side to determine if any of the following conditions are present: loss of receive frame synchronization, AIS alarm (all 1s) reception, or loss of receive carrier (or signal). If any one (or more) of the above conditions is present, then the DS2153Q will either force an AIS alarm (if CCR2.5 = 1) or a Remote Alarm (CCR2.4 = 1) to be transmitted via the TTIP and TRING pins. It is an illegal state to have both CCR2.4 and CCR2.5 set to 1 at the same time.

## 4.5 Power-Up Sequence

On power-up, after the supplies are stable, the DS2153Q should be configured for operation by writing to all of the internal registers (this includes setting the Test Register) since the contents of the internal registers cannot be predicted on power-up. Next, the LIRST bit should be toggled from 0 to 1 to reset the line interface circuitry (it will take the DS2153Q about 40ms to recover from the LIRST being toggled). Finally, after the SYSCLK input is stable, the ESR bit should be toggled from a 0 to a 1 and back to 0 (this step can be skipped if the elastic stores are disabled).

## 5 STATUS AND INFORMATION REGISTERS

There is a set of four registers that contain information on the current real-time status of the DS2153Q: Status Register 1 (SR1), Status Register 2 (SR2), Receive Information Register (RIR), and Synchronizer Status Register (SSR). When a particular event has occurred (or is occurring), the appropriate bit in one of these four registers will be set to a 1. All of the bits in these registers operate in a latched fashion (except for the SSR). This means that if an event occurs and a bit is set to a 1 in any of the registers, it will remain set until the user reads that bit. The bit will be cleared when it is read and it will not be set again until the event has occurred again or if the alarm is still present.

The user will always precede a read of the SR1, SR2, and RIR registers with a write. The byte written to the register will inform the DS2153Q which bits the user wishes to read and have cleared. The user will write a byte to one of these three registers, with a 1 in the bit positions he or she wishes to read and a 0 in the bit positions he or she does not wish to obtain the latest information on. When a 1 is written to a bit location, the read register will be updated with current value and it will be cleared. When a 0 is written to a bit position, the read register will not be updated and the previous value will be held. A write to the status and information registers will be immediately followed by a read of the same register. The read result should be logically ANDed with the mask byte that was just written and this value should be written back into the same register to insure that bit does indeed clear. This second write step is necessary because the alarms and events in the status registers occur asynchronously in respect to their access via the parallel port. This write-read-write scheme allows an external microcontroller or microprocessor to individually poll certain bits without disturbing the other bits in the register. This operation is key in controlling the DS2153Q with higher-order software languages.

The SSR register operates differently than the other three. It is a read-only register and it reports the status of the synchronizer in real time. This register is not latched and it is not necessary to precede a read of this register with a write.

The SR1 and SR2 registers have the unique ability to initiate a hardware interrupt via the  $\overline{\text{INT1}}$  and  $\overline{\text{INT2}}$  pins, respectively. Each of the alarms and events in the SR1 and SR2 can be either masked or unmasked from the interrupt pins via the Interrupt Mask Register 1 (IMR1) and Interrupt Mask Register 2 (IMR2), respectively.

**RIR: RECEIVE INFORMATION REGISTER (Address = 08 Hex)**

<b>(MSB)</b>						<b>(LSB)</b>	
TESF	TESE	JALT	RESF	RESE	CRCRC	FASRC	CASRC

SYMBOL	POSITION	NAME AND DESCRIPTION
TESF	RIR.7	<b>Transmit Elastic Store Full.</b> Set when the elastic store fills and a frame is deleted.
TESE	RIR.6	<b>Transmit Elastic Store Empty.</b> Set when the elastic store empties and a frame is repeated.
JALT	RIR.5	<b>Jitter Attenuator Limit Trip.</b> Set when the jitter attenuator FIFO reaches to within 4 bits of its limit; useful for debugging jitter attenuation operation.
RESF	RIR.4	<b>Elastic Store Full.</b> Set when the elastic store buffer fills and a frame is deleted.
RESE	RIR.3	<b>Elastic Store Empty.</b> Set when the elastic store buffer empties and a frame is repeated.
CRCRC	RIR.2	<b>CRC Resync Criteria Met.</b> Set when 915/1000 codewords are received in error.
FASRC	RIR.1	<b>FAS Resync Criteria Met.</b> Set when three consecutive FAS words are received in error.
CASRC	RIR.0	<b>CAS Resync Criteria Met.</b> Set when two consecutive CAS MF alignment words are received in error.

**SSR: SYNCHRONIZER STATUS REGISTER (Address = 1E Hex)**

(MSB)						(LSB)	
CSC5	CSC4	CSC3	CSC2	CSC0	FASSA	CASSA	CRC4SA

SYMBOL	POSITION	NAME AND DESCRIPTION
CSC5	SSR.7	<b>CRC4 Sync Counter Bit 5.</b> MSB of the 6-bit counter.
CSC4	SSR.6	<b>CRC4 Sync Counter Bit 4.</b>
CSC3	SSR.5	<b>CRC4 Sync Counter Bit 3.</b>
CSC2	SSR.4	<b>CRC4 Sync Counter Bit 2.</b>
CSC0	SSR.3	<b>CRC4 Sync Counter Bit 0.</b> LSB of the 6-bit counter. The next to LSB bit is not accessible. This bit will toggle each time the CRC4 MF search times out at 8ms.
FASSA	SSR.2	<b>FAS Sync Active.</b> Set while the synchronizer is searching for alignment at the FAS level.
CASSA	SSR.1	<b>CAS MF Sync Active.</b> Set while the synchronizer is searching for the CAS MF alignment word.
CRC4SA	SSR.0	<b>CRC4 MF Sync Active.</b> Set while the synchronizer is searching for the CRC4 MF alignment word.

**5.1 CRC4 Sync Counter**

The CRC4 sync counter increments each time the 8ms CRC4 multiframe search times out. The counter is cleared when the DS2153Q has successfully obtained synchronization at the CRC4 level. The counter can also be cleared by disabling the CRC4 mode (CCR1.0 = 0). This counter is useful for determining the amount of time the DS2153Q has been searching for synchronization at the CRC4 level. Annex B of CCITT G.706 suggests that if synchronization at the CRC4 level cannot be obtained within 400ms, then the search should be abandoned and proper action taken. The CRC4 sync counter will rollover.

**SR1: STATUS REGISTER 1 (Address = 06 Hex)**

(MSB)							(LSB)
RSA1	RDMA	RSA0	RSLIP	RUA1	RRA	RCL	RLOS

SYMBOL	POSITION	NAME AND DESCRIPTION
RSA1	SR1.7	<b>Receive Signaling All 1s.</b> Set when the contents of time slot 16 contains less than three 0s over 16 consecutive frames. This alarm is not disabled in the CCS signaling mode.
RDMA	SR1.6	<b>Receive Distant MF Alarm.</b> Set when bit 6 of time slot 16 in frame 0 has been set for two consecutive multiframes. This alarm is not disabled in the CCS signaling mode.
RSA0	SR1.5	<b>Receive Signaling All 0s.</b> Set when over a full MF, time slot 16 contains all 0s.
RSLIP	SR1.4	<b>Receive Elastic Store Slip Occurrence.</b> Set when the elastic store has either repeated or deleted a frame of data.
RUA1	SR1.3	<b>Receive Unframed All 1s.</b> Set when an unframed all 1s code is received at RTIP and RRING.
RRA	SR1.2	<b>Receive Remote Alarm.</b> Set when a remote alarm is received at RTIP and RRING.
RCL	SR1.1	<b>Receive Carrier Loss.</b> Set when 255 consecutive 0s have been detected at RTIP and RRING.
RLOS	SR1.0	<b>Receive Loss of Sync.</b> Set when the device is not synchronized to the receive E1 stream.

**Table 5-1. Alarm Set and Clear Criteria**

<b>ALARM</b>	<b>SET CRITERIA</b>	<b>CLEAR CRITERIA</b>	<b>CCITT SPEC.</b>
<b>RSA1</b> (receive signaling all 1s)	Over 16 consecutive frames (one full MF) time slot 16 contains less than three 0s	Over 16 consecutive frames (one full MF) time slot 16 contains three or more 0s	G.732 4.2
<b>RSA0</b> (receive signaling all 0s)	Over 16 consecutive frames (one full MF) time slot 16 contains all 0s	Over 16 consecutive frames (one full MF) time slot 16 contains at least a single 1	G.732 5.2
<b>RDMA</b> (receive distant multiframe alarm)	Bit 6 in time slot 16 of frame 0 set to 1 for two consecutive MF	Bit 6 in time slot 16 of frame 0 set to 0 for a two consecutive MF	O.162 2.1.5
<b>RUA1</b> (receive unframed all 1s)	Less than three 0s in two frames (512 bits)	More than two 0s in two frames (512 bits)	O.162 1.6.1.2
<b>RRA</b> (receive remote alarm)	Bit 3 of non-align frame set to 1 for three consecutive occasions	Bit 3 of non-align frame set to 0 for three consecutive occasions	O.162 2.1.4
<b>RCL</b> (receive carrier loss)	255 consecutive 0s received	In 255-bit times, at least 32 1s are received	G.775

**SR2: STATUS REGISTER 2 (Address = 07 Hex)**

(MSB)						(LSB)	
RMF	RAF	TMF	SEC	TAF	LOTC	RCMF	TSLIP

SYMBOL	POSITION	NAME AND DESCRIPTION
RMF	SR2.7	<b>Receive CAS Multiframe.</b> Set every 2ms (regardless if CAS signaling is enabled or not) on receive multiframe boundaries. Used to alert the host that signaling data is available.
RAF	SR2.6	<b>Receive Align Frame.</b> Set every 250ms at the beginning of align frames. Used to alert the host that Si and Sa bits are available in the RAF and RNAF registers.
TMF	SR2.5	<b>Transmit Multiframe.</b> Set every 2 $\mu$ s (regardless if CRC4 is enabled) on transmit multiframe boundaries. Used to alert the host that signaling data needs to be updated.
SEC	SR2.4	<b>1-Second Timer.</b> Set on increments of 1 second based on RCLK. If CCR2.7 = 1, then this bit will be set every 62.5ms instead of once a second.
TAF	SR2.3	<b>Transmit Align Frame.</b> Set every 250 $\mu$ s at the beginning of align frames. Used to alert the host that the TAF and TNAF registers need to be updated.
LOTC	SR2.2	<b>Loss of Transmit Clock.</b> Set when the TCLK pin has not transitioned for one channel time (or 3.9 $\mu$ s). Will force pin 16 high if enabled via TCR2.0. Based on RCLK.
RCMF	SR2.1	<b>Receive CRC4 Multiframe.</b> Set on CRC4 multiframe boundaries; will continue to be set every 2ms on an arbitrary boundary if CRC4 is disabled.
TSLIP	SR2.0	<b>Transmit Elastic Store Slip.</b> Set when the elastic store has either repeated or deleted a frame of data.

**IMR1: INTERRUPT MASK REGISTER1 (Address = 16 Hex)**

<b>(MSB)</b>							<b>(LSB)</b>
RSA1	RDMA	RSA0	RSLIP	RUA1	RRA	RCL	RLOS

<b>SYMBOL</b>	<b>POSITION</b>	<b>NAME AND DESCRIPTION</b>
RSA1	IMR1.7	<b>Receive Signaling All 1s.</b> 0 = interrupt masked 1 = interrupt enabled
RDMA	IMR1.6	<b>Receive Distant MF Alarm.</b> 0 = interrupt masked 1 = interrupt enabled
RSA0	IMR1.5	<b>Receive Signaling All 0s.</b> 0 = interrupt masked 1 = interrupt enabled
RSLIP	IMR1.4	<b>Receive Elastic Store Slip Occurrence.</b> 0 = interrupt masked 1 = interrupt enabled
RUA1	IMR1.3	<b>Receive Unframed All 1s.</b> 0 = interrupt masked 1 = interrupt enabled
RRA	IMR1.2	<b>Receive Remote Alarm.</b> 0 = interrupt masked 1 = interrupt enabled
RCL	IMR1.1	<b>Receive Carrier Loss.</b> 0 = interrupt masked 1 = interrupt enabled
RLOS	IMR1.0	<b>Receive Loss of Sync.</b> 0 = interrupt masked 1 = interrupt enabled



**IMR2: INTERRUPT MASK REGISTER 2 (Address = 17 Hex)**

<b>(MSB)</b>						<b>(LSB)</b>	
RMF	RAF	TMF	SEC	TAF	LOTC	RCMF	TSLIP

<b>SYMBOL</b>	<b>POSITION</b>	<b>NAME AND DESCRIPTION</b>
RMF	IMR2.7	<b>Receive CAS Multiframe.</b> 0 = interrupt masked 1 = interrupt enabled
RAF	IMR2.6	<b>Receive Align Frame.</b> 0 = interrupt masked 1 = interrupt enabled
TMF	IMR2.5	<b>Transmit Multiframe.</b> 0 = interrupt masked 1 = interrupt enabled
SEC	IMR2.4	<b>1-Second Timer.</b> 0 = interrupt masked 1 = interrupt enabled
TAF	IMR2.3	<b>Transmit Align Frame.</b> 0 = interrupt masked 1 = interrupt enabled
LOTC	IMR2.2	<b>Loss Of Transmit Clock.</b> 0 = interrupt masked 1 = interrupt enabled
RCMF	IMR2.1	<b>Receive CRC4 Multiframe.</b> 0 = interrupt masked 1 = interrupt enabled
TSLIP	IMR2.0	<b>Transmit Side Elastic Store Slip.</b> 0 = interrupt masked 1 = interrupt enabled

## 6 ERROR COUNT REGISTERS

There are a set of four counters in the DS2153Q that record bipolar or code violations, errors in the CRC4 SMF codewords, E bits as reported by the far end, and word errors in the FAS. Each of these four counters are automatically updated on either 1-second boundaries (CCR2.7 = 0) or every 62.5ms (CCR2.7 = 1) as determined by the timer in Status Register 2 (SR2.4). Hence, these registers contain performance data from either the previous second or the previous 62.5ms. The user can use the interrupt from the timer to determine when to read these registers. The user has a full second (or 62.5ms) to read the counters before the data is lost.

### 6.1 BPV or Code Violation Counter

Violation Count Register 1 (VCR1) is the most significant word and VCR2 is the least significant word of a 16-bit counter that records either Bipolar Violations (BPVs) or Code Violations (CVs). If CCR2.6 = 0, then the VCR counts bipolar violations. Bipolar violations are defined as consecutive marks of the same polarity. In this mode, if the HDB3 mode is set for the receive side via CCR1.2, then HDB3 codewords are not counted as BPVs. If CCR2.6 = 1, then the VCR counts code violations as defined in CCITT O.161. Code violations are defined as consecutive bipolar violations of the same polarity. In most applications, the DS2153Q should be programmed to count BPVs when receiving AMI code and to count CVs when receiving HDB3 code. This counter increments at all times and is not disabled by loss of sync conditions. The counter saturates at 65,535 and will not rollover. The bit error rate on an E1 line would have to be greater than  $10^{-2}$  before the VCR would saturate.

**VCR1: UPPER BIPOLAR VIOLATION COUNT REGISTER 1 (Address = 00 Hex)**

**VCR2: LOWER BIPOLAR VIOLATION COUNT REGISTER 2 (Address = 01 Hex)**

(MSB)							(LSB)	
V15	V14	V13	V12	V11	V10	V9	V8	VCR1
V7	V6	V5	V4	V3	V2	V1	V0	VCR2

SYMBOL	POSITION	NAME AND DESCRIPTION
V15	VCR1.7	MSB of the 16-bit bipolar or code violation count.
V0	VCR2.0	LSB of the 16-bit bipolar or code violation count.

## 6.2 CRC4 Error Counter

CRC4 Count Register 1 (CRCCR1) is the most significant word and CRCCR2 is the least significant word of a 10-bit counter that records word errors in the Cyclic Redundancy Check 4 (CRC4). Since the maximum CRC4 count in a 1-second period is 1000, this counter cannot saturate. The counter is disabled during loss of sync at either the FAS or CRC4 level; it will continue to count if loss of multiframe sync occurs at the CAS level.

### CRCCR1: CRC4 COUNT REGISTER 1 (Address = 02 Hex)

### CRCCR2: CRC4 COUNT REGISTER 2 (Address = 03 Hex)

(MSB)						(LSB)		
(See note)	(See note)	(See note)	(See note)	(See note)	(See note)	CRC9	CRC8	CRCCR1
CRC7	CRC6	CRC5	CRC4	CRC3	CRC2	CRC1	CRC0	CRCCR2

SYMBOL	POSITION	NAME AND DESCRIPTION
CRC9	CRCCR1.1	MSB of the 10-bit CRC4 error count.
CRC0	CRCCR2.0	LSB of the 10-bit CRC4 error count.

*Note:* The upper 6 bits of CRCCR1 at address 02 are the most significant bits of the 12-bit FAS error counter.

## 6.3 E-Bit Counter

E-bit Count Register 1 (EBCR1) is the most significant word and EBCR2 is the least significant word of a 10-bit counter that records Far End Block Errors (FEBE) as reported in the first bit of frames 13 and 15 on E1 lines running with CRC4 multiframe. These count registers will increment once each time the received E-bit is set to 0. Since the maximum E-bit count in a 1-second period is 1000, this counter cannot saturate. The counter is disabled during loss of sync at either the FAS or CRC4 level; it will continue to count if loss of multiframe sync occurs at the CAS level.

### EBCR1: E-BIT COUNT REGISTER 1 (Address = 04 Hex)

### EBCR2: E-BIT COUNT REGISTER 2 (Address = 05 Hex)

(MSB)						(LSB)		
(See note)	(See note)	(See note)	(See note)	(See note)	(See note)	EB9	EB8	EBCR1
EB7	EB6	EB5	EB4	EB3	EB2	EB1	EB0	EBCR2

SYMBOL	POSITION	NAME AND DESCRIPTION
EB9	EBCR1.1	MSB of the 10-bit E-bit count.
EB0	EBCR2.0	LSB of the 10-bit E-bit count.

*Note:* The upper 6 bits of EBCR1 at address 04 are the least significant bits of the 12-bit FAS error counter.

## 6.4 FAS Bit Error Counter

FAS Count Register 1 (FASCR1) is the most significant word and FASCR2 is the least significant word of a 12-bit counter that records word errors in the Frame Alignment Signal in time slot 0. This counter is disabled during loss of synchronization conditions, (RLOS = 1). Since the maximum FAS word error count in a 1-second period is 4000, this counter cannot saturate.

### FASCR1: FAS BIT COUNT REGISTER 1 (Address = 02 Hex)

### FASCR2: FAS BIT COUNT REGISTER 2 (Address = 04 Hex)

(MSB)						(LSB)		
FAS11	FAS10	FAS9	FAS8	FAS7	FAS6	(Note 1)	(Note 1)	FASCR1
FAS5	FAS4	FAS3	FAS2	FAS1	FAS0	(Note 2)	(Note 2)	FASCR2

SYMBOL	POSITION	NAME AND DESCRIPTION
FAS11	FASCR1.7	MSB of the 12-bit FAS error count.
FAS0	FASCR2.2	LSB of the 12-bit FAS error count.

**Note 1:** The lower 2 bits of FASCR1 at address 02 are the most significant bits of the 10-bit CRC4 error counter.

**Note 2:** The lower 2 bits of FASCR2 at address 04 are the most significant bits of the 10-bit E-bit counter.

## 7 Sa DATA LINK CONTROL AND OPERATION

The DS2153Q provides for access to the proposed E1 performance monitor data link in the Sa bit positions. The device allows access to the Sa bits either via a set of two internal registers (RNAF and TNAF) or via two external pins (RLINK and TLINK).

On the receive side, the Sa bits are always reported in the internal RNAF register (see Section [12](#) for more details). All five Sa bits are always output at the RLINK pin. See Section [14](#) for detailed timing. Via RCR2, the user can control the RLCLK pin to pulse during any combination of Sa bits. This allows the user to create a clock that can be used to capture the needed Sa bits.

On the transmit side, the individual Sa bits can be either sourced from the internal TNAF register (TCR1.6 = 0) or from the external TLINK pin. Via TCR2, the DS2153Q can be programmed to source any combination of the additional bits from the TLINK pin. If the user wishes to pass the Sa bits through the DS2153Q without them being altered, then the device should be set up to source all five Sa bits via the TLINK pin and the TLINK pin should be tied to the TSER pin. See the timing diagrams and the transmit data flow diagram in Section [14](#) for examples.

## 8 SIGNALING OPERATION

The Channel Associated Signaling (CAS) bits embedded in the E1 stream can be extracted from the receive stream and inserted into the transmit stream by the DS2153Q. Each of the 30 channels has four signaling bits (A/B/C/D) associated with it. The numbers in parentheses are the channel associated with a particular signaling bit. The channel numbers have been assigned as described in the ITU documents. For example, channel 1 is associated with time slot 1 and channel 30 is associated with time slot 31. There is a set of 16 registers for the receive side (RS1 to RS16) and 16 registers on the transmit side (TS1 to TS16). The signaling registers are detailed below.

### RS1 TO RS16: RECEIVE SIGNALING REGISTERS (Address = 30 to 3F Hex)

(MSB)				(LSB)				
0	0	0	0	X	Y	X	X	
A(1)	B(1)	C(1)	D(1)	A(16)	B(16)	C(16)	D(16)	RS1 (30)
A(2)	B(2)	C(2)	D(2)	A(17)	B(17)	C(17)	D(17)	RS2 (31)
A(3)	B(3)	C(3)	D(3)	A(18)	B(18)	C(18)	D(18)	RS3 (32)
A(4)	B(4)	C(4)	D(4)	A(19)	B(19)	C(19)	D(19)	RS4 (33)
A(5)	B(5)	C(5)	D(5)	A(20)	B(20)	C(20)	D(20)	RS5 (34)
A(6)	B(6)	C(6)	D(6)	A(21)	B(21)	C(21)	D(21)	RS6 (35)
A(7)	B(7)	C(7)	D(7)	A(22)	B(22)	C(22)	D(22)	RS7 (33)
A(8)	B(8)	C(8)	D(8)	A(23)	B(23)	C(23)	D(23)	RS8 (37)
A(9)	B(9)	C(9)	D(9)	A(24)	B(24)	C(24)	D(24)	RS9 (38)
A(10)	B(10)	C(10)	D(10)	A(25)	B(25)	C(25)	D(25)	RS10 (39)
A(11)	B(11)	C(11)	D(11)	A(26)	B(26)	C(26)	D(26)	RS11 (3A)
A(12)	B(12)	C(12)	D(12)	A(27)	B(27)	C(27)	D(27)	RS12 (3B)
A(13)	B(13)	C(13)	D(13)	A(28)	B(28)	C(28)	D(28)	RS13 (3C)
A(14)	B(14)	C(14)	D(14)	A(29)	B(29)	C(29)	D(29)	RS14 (3D)
A(15)	B(15)	C(15)	D(15)	A(30)	B(30)	C(30)	D(30)	RS15 (3E)
								RS16 (3F)

SYMBOL	POSITION	NAME AND DESCRIPTION
X	RS1.0/1/3	<b>Spare Bits</b>
Y	RS1.2	<b>Remote Alarm Bit (integrated and reported in SR1.6)</b>
A(1)	RS2.7	<b>Signaling Bit A for Channel 1</b>
D(30)	RS16.0	<b>Signaling Bit D for Channel 30</b>

Each Receive Signaling Register (RS1 to RS16) reports the incoming signaling from two time slots. The bits in the Receive Signaling Registers are updated on multiframe boundaries so the user can utilize the Receive Multiframe Interrupt in the Receive Status Register 2 (SR2.7) to know when to retrieve the signaling bits. The user has a full 2ms to retrieve the signaling bits before the data is lost. The RS registers are updated under all conditions. Their validity should be qualified by checking for synchronization at the CAS level. In CCS signaling mode, RS1 to RS16 can also be used to extract signaling information. Via the SR2.7 bit, the user will be informed when the signaling registers have been loaded with data. The user has 2ms to retrieve the data before it is lost.

**TS1 TO TS16: TRANSMIT SIGNALING REGISTERS (Address = 40 to 4F Hex)**

(MSB)				(LSB)				
0	0	0	0	X	Y	X	X	
A(1)	B(1)	C(1)	D(1)	A(31)	B(16)	C(16)	D(16)	TS1 (40)
A(2)	B(2)	C(2)	D(2)	A(32)	B(17)	C(17)	D(17)	TS2 (41)
A(3)	B(3)	C(3)	D(3)	A(33)	B(18)	C(18)	D(18)	TS3 (42)
A(4)	B(4)	C(4)	D(4)	A(34)	B(19)	C(19)	D(19)	TS4 (43)
A(5)	B(5)	C(5)	D(5)	A(35)	B(20)	C(20)	D(20)	TS5 (44)
A(6)	B(6)	C(6)	D(6)	A(36)	B(21)	C(21)	D(21)	TS6 (45)
A(7)	B(7)	C(7)	D(7)	A(37)	B(22)	C(22)	D(22)	TS7 (43)
A(8)	B(8)	C(8)	D(8)	A(38)	B(23)	C(23)	D(23)	TS8 (47)
A(9)	B(9)	C(9)	D(9)	A(39)	B(24)	C(24)	D(24)	TS9 (48)
A(10)	B(10)	C(10)	D(10)	A(40)	B(25)	C(25)	D(25)	TS10 (49)
A(11)	B(11)	C(11)	D(11)	A(41)	B(26)	C(26)	D(26)	TS11 (4A)
A(12)	B(12)	C(12)	D(12)	A(42)	B(27)	C(27)	D(27)	TS12 (4B)
A(13)	B(13)	C(13)	D(13)	A(43)	B(28)	C(28)	D(28)	TS13 (4C)
A(14)	B(14)	C(14)	D(14)	A(44)	B(29)	C(29)	D(29)	TS14 (4D)
A(15)	B(15)	C(15)	D(15)	A(45)	B(30)	C(30)	D(30)	TS15 (43)
								TS16 (4F)

SYMBOL	POSITION	NAME AND DESCRIPTION
X	TS1.0/1/3	<b>Spare Bits</b>
Y	TS1.2	<b>Remote Alarm Bit</b>
A(1)	TS2.7	<b>Signaling Bit A for Channel 1</b>
D(30)	TS16.0	<b>Signaling Bit D for Channel 30</b>

Each Transmit Signaling Register (TS1 to TS16) contains the CAS bits for two time slots that will be inserted into the outgoing stream if enabled to do so via TCR1.5. On multiframe boundaries, the DS2153Q will load the values present in the Transmit Signaling Register into an outgoing signaling shift register that is internal to the device. The user can utilize the Transmit Multiframe bit in Status Register 2 (SR2.5) to know when to update the signaling bits. The bit will be set every 2ms and the user has 2ms to update the TSRs before the old data will be retransmitted.

The TS1 register is special because it contains the CAS multiframe alignment word in its upper nibble. The upper nibble must always be set to 0000, or else the terminal at the far end will lose multiframe synchronization. If the user wishes to transmit a multiframe alarm to the far end, then the TS1.2 bit should be set to a 1. If no alarm is to be transmitted, then the TS1.2 bit should be cleared. The three remaining bits in TS1 are the spare bits. If they are not used, they should be set to 1. In CCS signaling mode, TS1 to TS16 can also be used to insert signaling information. Via the SR2.5 bit, the user will be informed when the signaling registers need to be loaded with data. The user has 2ms to load the data before the old data will be retransmitted. Via the CCR3.6 bit, the user has the option to use the Transmit Channel Blocking Registers (TCBRs) to determine on a channel by channel basis which signaling bits are to be inserted via the TSRs (the corresponding bit in the TCBRs = 1) and which are to be sourced from the TSER pin (the corresponding bit in the TCBRs = 0). See the Transmit Data Flow diagram in Section 14 for more details.

## 9 TRANSMIT IDLE REGISTERS

There is a set of five registers in the DS2153Q that can be used to custom tailor the data that is to be transmitted onto the E1 line, on a channel-by-channel basis. Each of the 32 E1 channels can be forced to have a user-defined idle code inserted into them.

### TIR1/TIR2/TIR3/TIR4: TRANSMIT IDLE REGISTERS (Address = 26 to 29 Hex)

(MSB)				(LSB)				
CH8	CH7	CH6	CH5	CH4	CH3	CH2	CH1	TIR1 (26)
CH16	CH15	CH14	CH13	CH12	CH11	CH10	CH9	TIR2 (27)
CH24	CH23	CH22	CH21	CH20	CH19	CH18	CH17	TIR3 (28)
CH32	CH31	CH30	CH29	CH28	CH27	CH26	CH25	TIR4 (29)

SYMBOL	POSITION	NAME AND DESCRIPTION
--------	----------	----------------------

CH32	TIR4.7	<b>Transmit Idle Registers.</b> 0 = do not insert the Idle Code into this channel
------	--------	--

CH1	TIR1.0	1 = insert the Idle Code into this channel
-----	--------	--

*Note: If CCR3.5 = 1, then a 0 in the TIRs implies that channel data is to be sourced from TSER and a 1 implies that channel data is to be sourced from the RSER pin.*

### TIDR: TRANSMIT IDLE DEFINITION REGISTER (Address = 2A Hex)

(MSB)							(LSB)
TIDR7	TIDR6	TIDR5	TIDR4	TIDR3	TIDR2	TIDR1	TIDR0

SYMBOL	POSITION	NAME AND DESCRIPTION
--------	----------	----------------------

TIDR7	TIDR.7	MSB of the Idle Code
-------	--------	----------------------

TIDR0	TIDR.0	LSB of the Idle Code
-------	--------	----------------------

Each of the bit positions in the Transmit Idle Registers (TIR1/TIR2/TIR3/TIR4) represents a time slot in the outgoing frame. When these bits are set to a 1, the corresponding channel will transmit the Idle Code contained in the Transmit Idle Definition Register (TIDR). In the TIDR, the MSB is transmitted first. Via the CCR3.5 bit, the user has the option to use the TIRs to determine on a channel-by-channel basis, if data from the RSER pin should be substituted for data from the TSER pin. In this mode, if the corresponding bit in the TIRs is set to 1, then data will be sourced from the RSER pin. If the corresponding bit in the TIRs is set to 0, then data for that channel will sourced from the TSER pin. See the Transmit Data Flow diagram in Section [14](#) for more details.



## 10 CLOCK BLOCKING REGISTERS

The Receive Channel Blocking Registers (RCBR1/RCBR2/RCBR3/RCBR4) and the Transmit Channel Blocking Registers (TCBR1/TCBR2/TCBR3/TCBR4) control the RCHBLK and TCHBLK pins, respectively. The RCHBLK and TCHCLK pins are user-programmable outputs that can be forced either high or low during individual channels. These outputs can be used to block clocks to a USART or LAPD controller in ISDN-PRI applications. When the appropriate bits are set to a 1, the RCHBLK and TCHCLK pins will be held high during the entire corresponding channel time. See the timing diagrams in Section 14 for an example. The TCBRs have an alternate mode of use. Via the CCR3.6 bit, the user has the option to use the TCBRs to determine on a channel by channel basis, which signaling bits are to be inserted via the TSRs (the corresponding bit in the TCBRs = 1) and which are to be sourced from the TSER pin (the corresponding bit in the TCBR = 0). See the Transmit Data Flow diagram in Section 14 for more details.

### RCBR1/RCBR2/RCBR3/RCBR4: RECEIVE CHANNEL BLOCKING REGISTERS (Address = 2B to 2E Hex)

(MSB)				(LSB)				
CH8	CH7	CH6	CH5	CH4	CH3	CH2	CH1	RCBR1 (2B)
CH16	CH15	CH14	CH13	CH12	CH11	CH10	CH9	RCBR2 (2C)
CH24	CH23	CH22	CH21	CH20	CH19	CH18	CH17	RCBR3 (2D)
CH32	CH31	CH30	CH29	CH28	CH27	CH26	CH25	RCBR4 (2E)

SYMBOL	POSITION	NAME AND DESCRIPTION
		<b>Receive Channel Blocking Registers.</b>
CH32	RCBR4.7	0 = force the RCHBLK pin to remain low during this channel time
CH1	RCBR1.0	1 = force the RCHBLK pin high during this channel time

### TCBR1/TCBR2/TCBR3/TCBR4: TRANSMIT CHANNEL BLOCKING REGISTERS (Address = 22 to 25 Hex)

(MSB)				(LSB)				
CH8	CH7	CH6	CH5	CH4	CH3	CH2	CH1	TCBR1 (22)
CH16	CH15	CH14	CH13	CH12	CH11	CH10	CH9	TCBR2 (23)
CH24	CH23	CH22	CH21	CH20	CH19	CH18	CH17	TCBR3 (24)
CH32	CH31	CH30	CH29	CH28	CH27	CH26	CH25	TCBR4 (25)

SYMBOL	POSITION	NAME AND DESCRIPTION
		<b>Transmit Channel Blocking Registers.</b>
CH32	TCBR4.7	0 = force the TCHBLK pin to remain low during this channel time
CH1	TCBR1.0	1 = force the TCHBLK pin high during this channel time

*Note: If CCR3.6 = 1, then a 0 in the TCBRs implies that signaling data is to be sourced from TSER and a 1 implies that signaling data for that channel is to be sourced from the Transmit Signaling (TS) registers.*

**TCBR1/TCBR2/TCBR3/TCBR4: DEFINITION WHEN CCR3.6 = 1**

<b>(MSB)</b>				<b>(LSB)</b>				
CH20	CH4	CH19	CH3	CH18	CH2	CH17*	CH1*	TCBR1
CH24	CH8	CH23	CH7	CH22	CH6	CH21	CH5	TCBR2
CH28	CH12	CH27	CH11	CH26	CH10	CH25	CH9	TCBR3
CH32	CH16	CH31	CH15	CH30	CH14	CH29	CH13	TCBR4

\*CH1 and CH17 should be set to 1 to allow the internal TS1 register to create the CAS Multiframe Alignment Word and Spare/Remote Alarm bits.

## 11 ELASTIC STORES OPERATION

The DS2153Q has an on-board two-frame (512 bits) elastic store. This elastic store can be enabled via RCR2.1. If the elastic store is enabled (RCR2.1=1), then the user must provide either a 1.544MHz (RCR2.2 = 0) or 2.048MHz (RCR2.2 = 1) clock at the SYSCLK pin. If the elastic store is enabled, then the user has the option of either providing a frame sync at the RSYNC pin (RCR1.5 = 1) or having the RSYNC pin provide a pulse on frame or multiframe boundaries (RCR1.5 = 0). If the user wishes to obtain pulses at the frame boundary, then RCR1.6 must be set to 0, and if the user wishes to have pulses occur at the multiframe boundary, then RCR1.6 must be set to 1. If the user selects to apply a 1.544MHz clock to the SYSCLK pin, then every fourth channel will be deleted and the F-bit position inserted (forced to 1). Hence channels 1, 5, 9, 13, 17, 21, 25, and 29 (time slots 0, 4, 8, 12, 16, 20, 24, and 28) will be deleted. Also, in 1.544MHz applications, the RCHBLK output will not be active in channels 25 through 32 (or in other words, RCBR4 is not active). See Section [14](#) for more details. If the 512-bit elastic buffer either fills or empties, a controlled slip will occur. If the buffer empties, then a full frame of data (256 bits) will be repeated at RSER and the SR1.4 and RIR.3 bits will be set to 1. If the buffer fills, then a full frame of data will be deleted and the SR1.4 and RIR.4 bits will be set to 1.

## 12 ADDITIONAL (Sa) AND INTERNATIONAL (Si) BIT OPERATION

The DS2153Q provides for access to both the Additional (Sa) and International (Si) bits. On the receive side, the RAF and RNAF registers will always report the data as it received in the Additional and International bit locations. The RAF and RNAF registers are updated with the setting of the Receive Align Frame bit in Status Register 2 (SR2.6). The host can use the SR2.6 bit to know when to read the RAF and RNAF registers. It has 250 $\mu$ s to retrieve the data before it is lost.

On the transmit side, data is sampled from the TAF and TNAF registers with the setting of the Transmit Align Frame bit in Status Register 2 (SR2.3). The host can use the SR2.3 bit to know when to update the TAF and TNAF registers. It has 250 $\mu$ s to update the data or else the old data will be retransmitted. Data in the Si bit position will be overwritten if either the DS2153Q is programmed: (1) to source the Si bits from the TSER pin, (2) in the CRC4 mode, or (3) have automatic E-bit insertion enabled. Data in the Sa bit position will be overwritten if any of the TCR2.3 to TCR2.7 bits are set to 1. See the register descriptions for TCR1 and TCR2 and the Transmit Data Flow diagram in Section [14](#) for more details.

### RAF: RECEIVE ALIGN FRAME REGISTER (Address = 2F Hex)

(MSB)							(LSB)
Si	0	0	1	1	0	1	1

SYMBOL	POSITION	NAME AND DESCRIPTION
Si	RAF.7	<b>International Bit.</b>
0	RAF.6	<b>Frame Alignment Signal Bit.</b>
0	RAF.5	<b>Frame Alignment Signal Bit.</b>
1	RAF.4	<b>Frame Alignment Signal Bit.</b>
1	RAF.3	<b>Frame Alignment Signal Bit.</b>
0	RAF.2	<b>Frame Alignment Signal Bit.</b>
1	RAF.1	<b>Frame Alignment Signal Bit.</b>
1	RAF.0	<b>Frame Alignment Signal Bit.</b>

**RNAF: RECEIVE NON-ALIGN FRAME REGISTER (Address = 1F Hex)**

(MSB)	Si	1	A	Sa4	Sa5	Sa6	Sa7	Sa8	(LSB)
-------	----	---	---	-----	-----	-----	-----	-----	-------

SYMBOL	POSITION	NAME AND DESCRIPTION
Si	RNAF.7	<b>International Bit.</b>
1	RNAF.6	<b>Frame Non-Alignment Signal Bit.</b>
A	RNAF.5	<b>Remote Alarm.</b>
Sa4	RNAF.4	<b>Additional Bit 4.</b>
Sa5	RNAF.3	<b>Additional Bit 5.</b>
Sa6	RNAF.2	<b>Additional Bit 6.</b>
Sa7	RNAF.1	<b>Additional Bit 7.</b>
Sa8	RNAF.0	<b>Additional Bit 8.</b>

**TAF: TRANSMIT ALIGN FRAME REGISTER (Address = 20 Hex)**

(MSB)	Si	0	0	1	1	0	1	1	(LSB)
-------	----	---	---	---	---	---	---	---	-------

SYMBOL	POSITION	NAME AND DESCRIPTION
Si	TAF.7	<b>International Bit.</b>
0	TAF.6	<b>Frame Alignment Signal Bit.</b>
0	TAF.5	<b>Frame Alignment Signal Bit.</b>
1	TAF.4	<b>Frame Alignment Signal Bit.</b>
1	TAF.3	<b>Frame Alignment Signal Bit.</b>
0	TAF.2	<b>Frame Alignment Signal Bit.</b>
1	TAF.1	<b>Frame Alignment Signal Bit.</b>
1	TAF.0	<b>Frame Alignment Signal Bit.</b>

**TNAF: TRANSMIT NON-ALIGN FRAME REGISTER (Address = 21 Hex)****(MSB)****(LSB)**

Si	1	A	Sa4	Sa5	Sa6	Sa7	Sa8
----	---	---	-----	-----	-----	-----	-----

<b>SYMBOL</b>	<b>POSITION</b>	<b>NAME AND DESCRIPTION</b>
Si	TNAF.7	<b>International Bit.</b>
1	TNAF.6	<b>Frame Non-Alignment Signal Bit.</b>
A	TNAF.5	<b>Remote Alarm.</b>
Sa4	TNAF.4	<b>Additional Bit 4.</b>
Sa5	TNAF.3	<b>Additional Bit 5.</b>
Sa6	TNAF.2	<b>Additional Bit 6.</b>
Sa7	TNAF.1	<b>Additional Bit 7.</b>
Sa8	TNAF.0	<b>Additional Bit 8.</b>

### 13 LINE INTERFACE FUNCTIONS

The line interface function in the DS2153Q contains three sections: the receiver, which handles clock and data recovery; the transmitter, which waveshapes and drives the T1 line; and the jitter attenuator. Each of these three sections is controlled by the Line Interface Control Register (LICR), which is described below.

#### LICR: LINE INTERFACE CONTROL REGISTER (Address = 18 Hex)

(MSB)			(LSB)					
LB2	LB1	LB0	EGL	JAS	JABDS	DJA	TPD	LICR

SYMBOL	POSITION	NAME AND DESCRIPTION
LB2	LICR.7	<b>Line Build-Out Select Bit 2.</b> Sets the transmitter build out; see the <a href="#">Table 13-2</a> .
LB1	LICR.6	<b>Line Build-Out Select Bit 1.</b> Sets the transmitter build out; see the <a href="#">Table 13-2</a> .
LB0	LICR.5	<b>Line Build-Out Select Bit 0.</b> Sets the transmitter build out; see the <a href="#">Table 13-2</a> .
EGL	LICR.4	<b>Receive Equalizer Gain Limit.</b> 0 = -12dB 1 = -30dB
JAS	LICR.3	<b>Jitter Attenuator Select.</b> 0 = place the jitter attenuator on the receive side 1 = place the jitter attenuator on the transmit side
JABDS	LICR.2	<b>Jitter Attenuator Buffer Depth Select.</b> 0 = 128 bits 1 = 32 bits (use for delay sensitive applications)
DJA	LICR.1	<b>Disable Jitter Attenuator.</b> 0 = jitter attenuator enabled 1 = jitter attenuator disabled
TPD	LICR.0	<b>Transmit Power Down.</b> 0 = normal transmitter operation 1 = powers down the transmitter and tri-states the TTIP and TRING pins

### 13.1 Receive Clock and Data Recovery

The DS2153Q contains a digital clock recovery system. See [Figure 1-1](#) and [Figure 13-1](#) for more details. The DS2153Q couples to the receive E1 twisted pair or coax via a 1:1 transformer. See [Table 13-3](#) for transformer details. The DS2153Q automatically adjusts to the E1 signal being received at the RTIP and RRING pins and can handle E1 twisted pair cables of 0.6mm (22 AWG) from 0 to 1.5km in length. The crystal attached at the XTAL1 and XTAL2 pins is multiplied by 4 via an internal PLL and fed to the clock recovery system. The clock recovery system uses both edges of the clock from the PLL circuit to form a 32 times oversampler that is used to recover the clock and data. This oversampling technique offers outstanding jitter tolerance (see [Figure 13-2](#)).

Normally, the clock that is output at the RCLK pin is the recovered clock from the E1 AMI waveform presented at the RTIP and RRING inputs. When no AMI signal is present at RTIP and RRING, a Receive Carrier Loss (RCL) condition will occur and the RCLK can be sourced from either the ACLKI pin or from the crystal attached to the XTAL1 and XTAL2 pins. The DS2153Q will sense the ACLKI pin to determine if a clock is present. If no clock is applied to the ACLKI pin, then it should be tied to RVSS to prevent the device from falsely sensing a clock. See [Table 13-1](#). If the jitter attenuator is either placed in the transmit path or is disabled, the RCLK output can exhibit short high cycles of the clock. This is due to the highly oversampled digital clock recovery circuitry. If the jitter attenuator is placed in the receive path (as is the case in most applications), the jitter attenuator restores the RCLK to being close to 50% duty cycle. See the receive AC timing characteristics in Section [16](#) for more details.

**Table 13-1. Source of RCLK Upon RCL**

ACLKI PRESENT?	RECEIVE SIDE JITTER ATTENUATOR	TRANSMIT SIDE JITTER ATTENUATOR
Yes	ACLKI via the jitter attenuator	ACLKI
No	Centered crystal	TCLK via the jitter attenuator



## 13.2 Transmit Waveshaping and Line Driving

The DS2153Q uses a set of laser-trimmed delay lines along with a precision digital-to-analog converter (DAC) to create the waveforms that are transmitted onto the E1 line. The waveforms created by the DS2153Q meet the ITU specifications. See [Figure 13-3](#). The user will select which waveform is to be generated by properly programming the L0 to L2 bits in the Line Interface Control Register (LICR). The DS2153Q can set up in a number of various configurations depending on the application. See [Table 13-2](#) and [Figure 1-1](#).

**Table 13-2. LBO Select in LICR**

L2	L1	L0	APPLICATION	TRANSFORMER	RETURN LOSS (dB)	Rt ( $\Omega$ )
0	0	0	75 $\Omega$ normal	1:1.15 step-up	N.M.	0
0	0	1	120 $\Omega$ normal	1:1.15 step-up	N.M.	0
0	1	0	75 $\Omega$ normal with protection resistors	1:1.15 step-up	N.M.	8.2
0	1	1	120 $\Omega$ normal with protection resistors	1:1.15 step-up	N.M.	8.2
1	0	0	75 $\Omega$ with high return loss	1:1.15 step-up	21	27
1	1	0	75 $\Omega$ with high return loss	1:1.36 step-up	21	18
1	0	0	120 $\Omega$ with high return loss	1:1.36 step-up	21	27

*N.M.* = not meaningful

Due to the nature of the design of the transmitter in the DS2153Q, very little jitter (less than  $0.005U_{I-P-P}$  broadband from 10Hz to 100kHz) is added to the jitter present on TCLK. Also, the waveforms that they create are independent of the duty cycle of TCLK. The transmitter in the DS2153Q couples to the E1 transmit shielded twisted pair or coax via a 1:1.15 or 1:1.36 step-up transformer as shown in [Figure 13-1](#). For the devices to create the proper waveforms, the transformer used must meet the specifications listed in [Table 13-3](#).

**Table 13-3. Transformer Specifications**

SPECIFICATION	RECOMMENDED VALUE
Turns Ratio	1:1 (receive) and 1:1.15 or 1:1.36 (transmit) $\pm 5\%$
Primary Inductance	600 $\mu$ H minimum
Leakage Inductance	1.0 $\mu$ H maximum
Intertwining Capacitance	60pF maximum
DC Resistance	1.2 $\Omega$ maximum

### 13.3 Jitter Attenuator

The DS2153Q contains an on-board jitter attenuator that can be set to a depth of either 32 or 128 bits via the JABDS bit in the Line Interface Control Register (LICR). The 128-bit mode is used in applications where large excursions of wander are expected. The 32-bit mode is used in delay sensitive applications. The characteristics of the attenuation are shown in [Figure 13-4](#). The jitter attenuator can be placed in either the receive path or the transmit path by appropriately setting or clearing the JAS bit in the LICR. Also, the jitter attenuator can be disabled (in effect, removed) by setting the DJA bit in the LICR. In order for the jitter attenuator to operate properly, a crystal with the specifications listed in [Table 13-4](#) must be connected to the XTAL1 and XTAL2 pins.

The jitter attenuator divides the clock provided by the 8.192MHz crystal at the XTAL1 and XTAL2 pins to create an output clock that contains very little jitter. On-board circuitry will pull the crystal (by switching in or out load capacitance) to keep it long-term averaged to the same frequency as the incoming E1 signal. If the incoming jitter exceeds either  $120U_{I,P-P}$  (buffer depth is 128 bits) or  $28U_{I,P-P}$  (buffer depth is 32 bits), then the DS2153Q will divide the attached crystal by either 3.5 or 4.5 instead of the normal 4 to keep the buffer from overflowing. When the device divides by either 3.5 or 4.5, it also sets the Jitter Attenuator Limit Trip (JALT) bit in the Receive Information Register (RIR.5).

**Table 13-4. Crystal Selection Guidelines**

PARAMETER	SPECIFICATION
Parallel Resonant Frequency	8.192MHz
Mode	Fundamental
Load Capacitance	18pF to 20pF (18.5pF nominal)
Tolerance	$\pm 50$ ppm
Pullability	$C_L = 10$ pF, delta frequency = +175ppm to +250ppm $C_L = 45$ pF, delta frequency = -175ppm to -250ppm
Effective Series Resistance	30 $\Omega$ maximum
Crystal Cut	AT

Figure 13-1. External Analog Connections

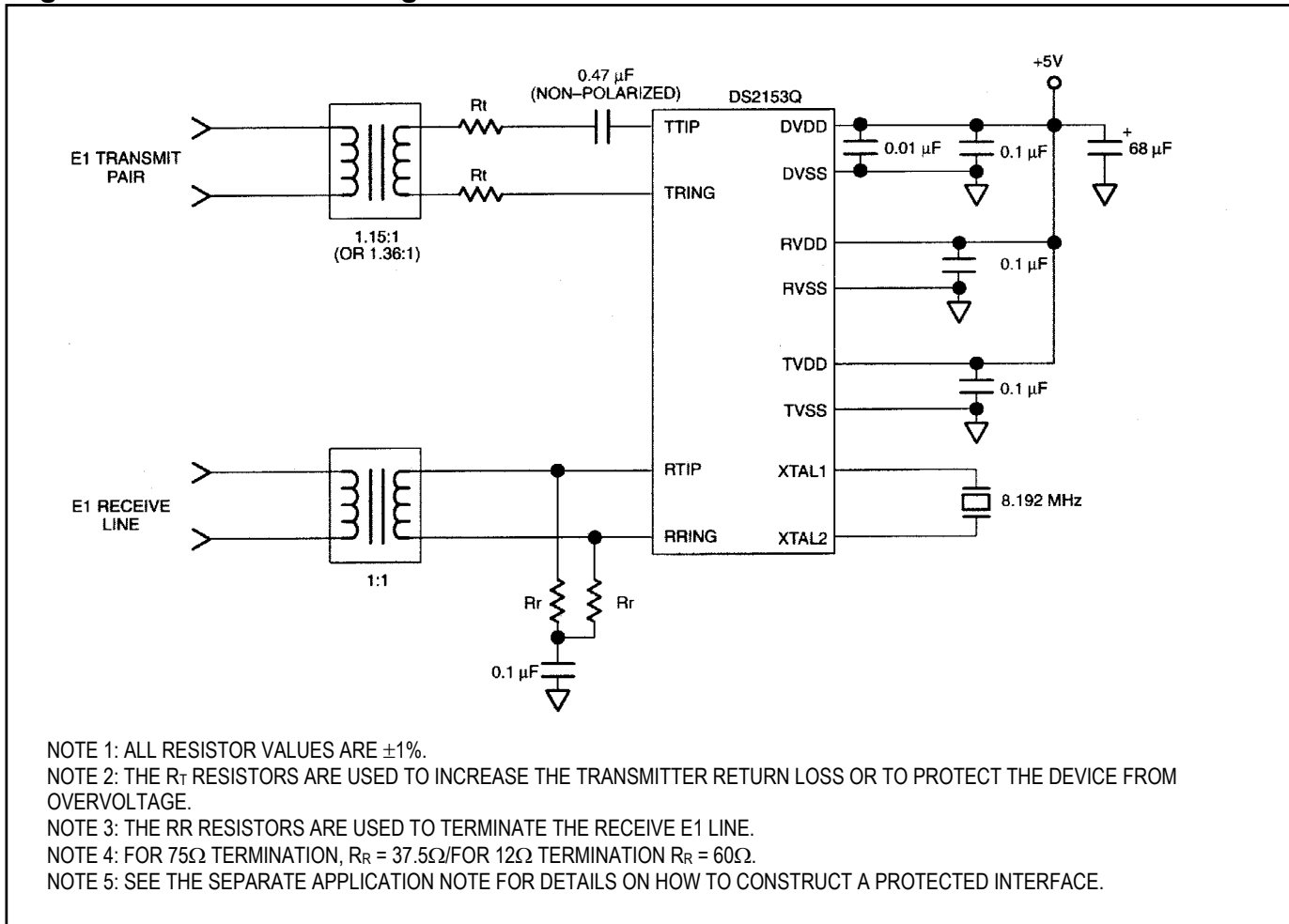


Figure 13-2. Jitter Tolerance

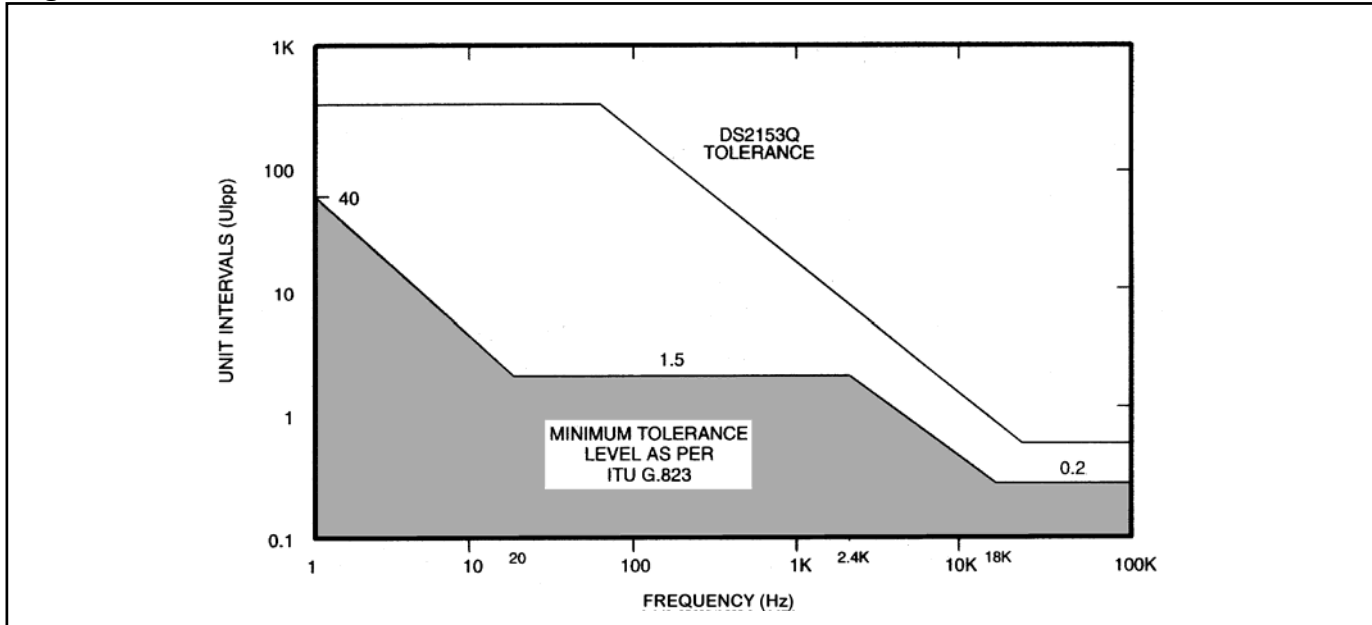
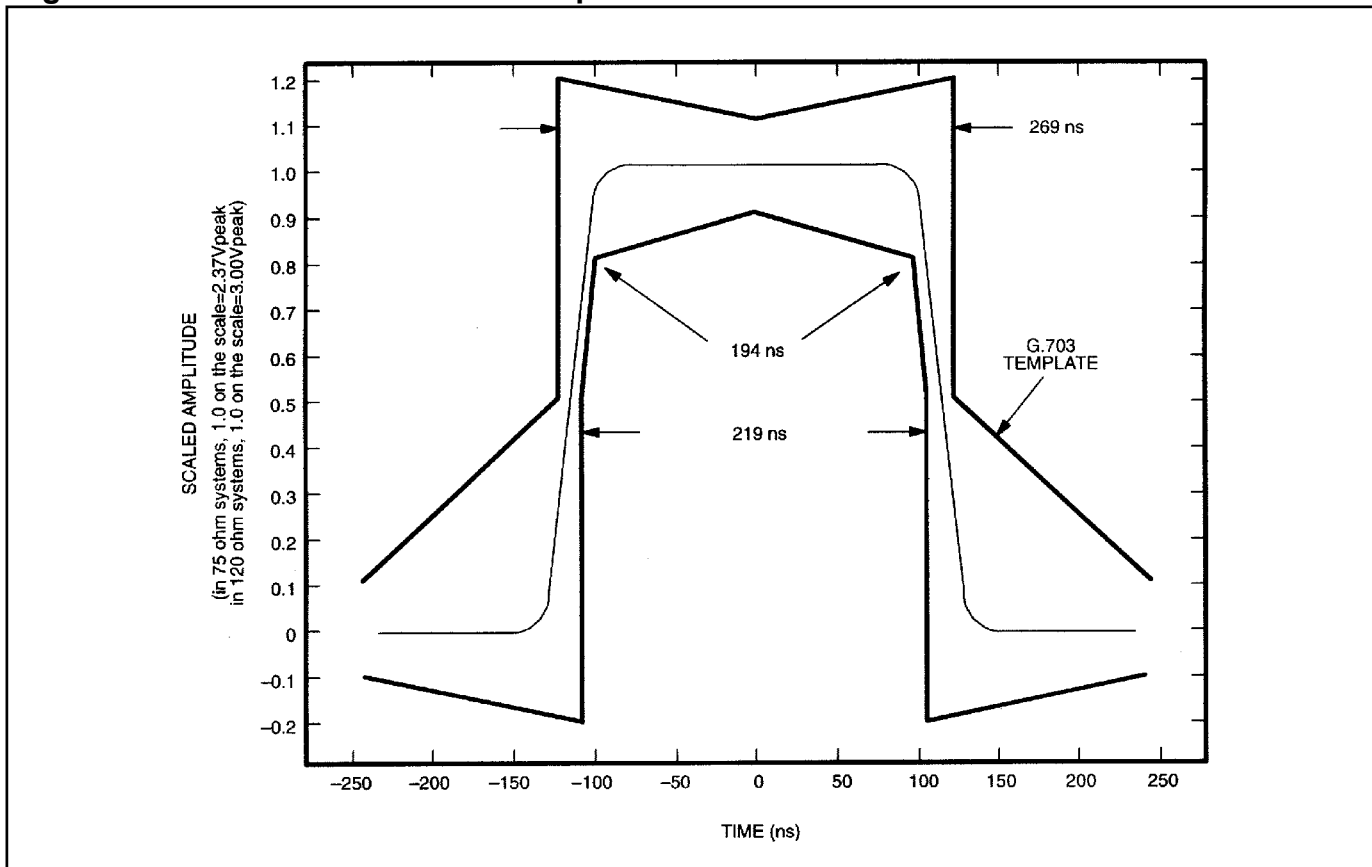
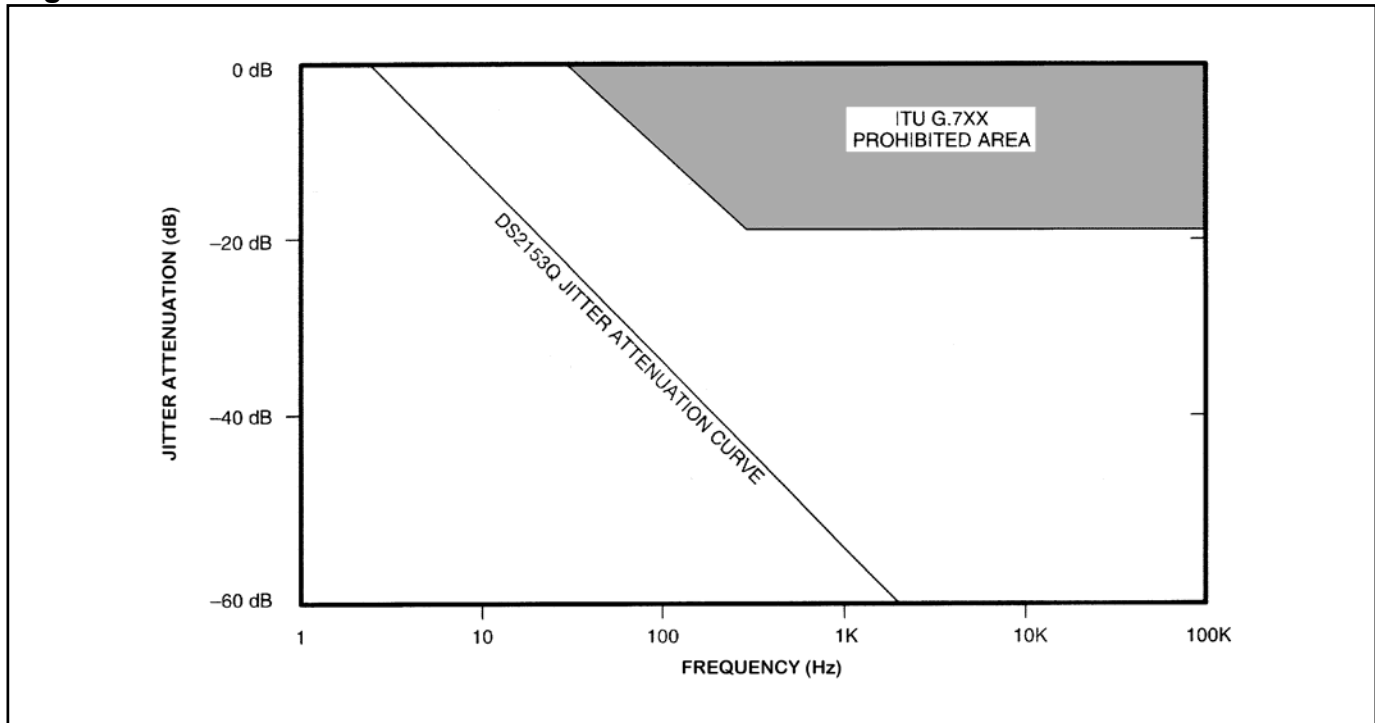


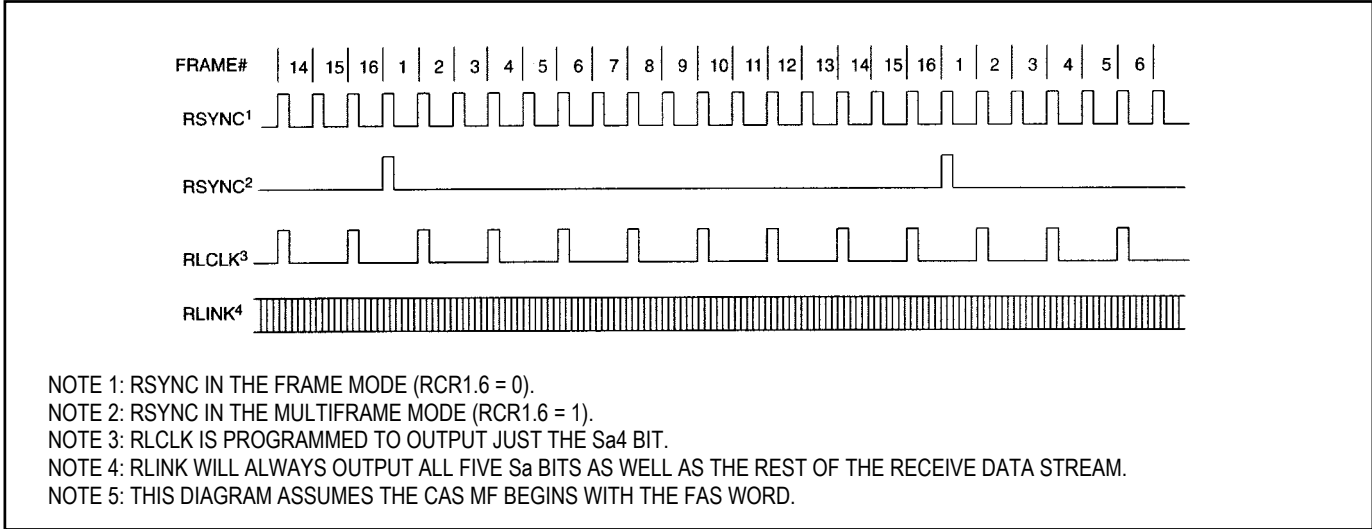
Figure 13-3. Transmit Waveform Template



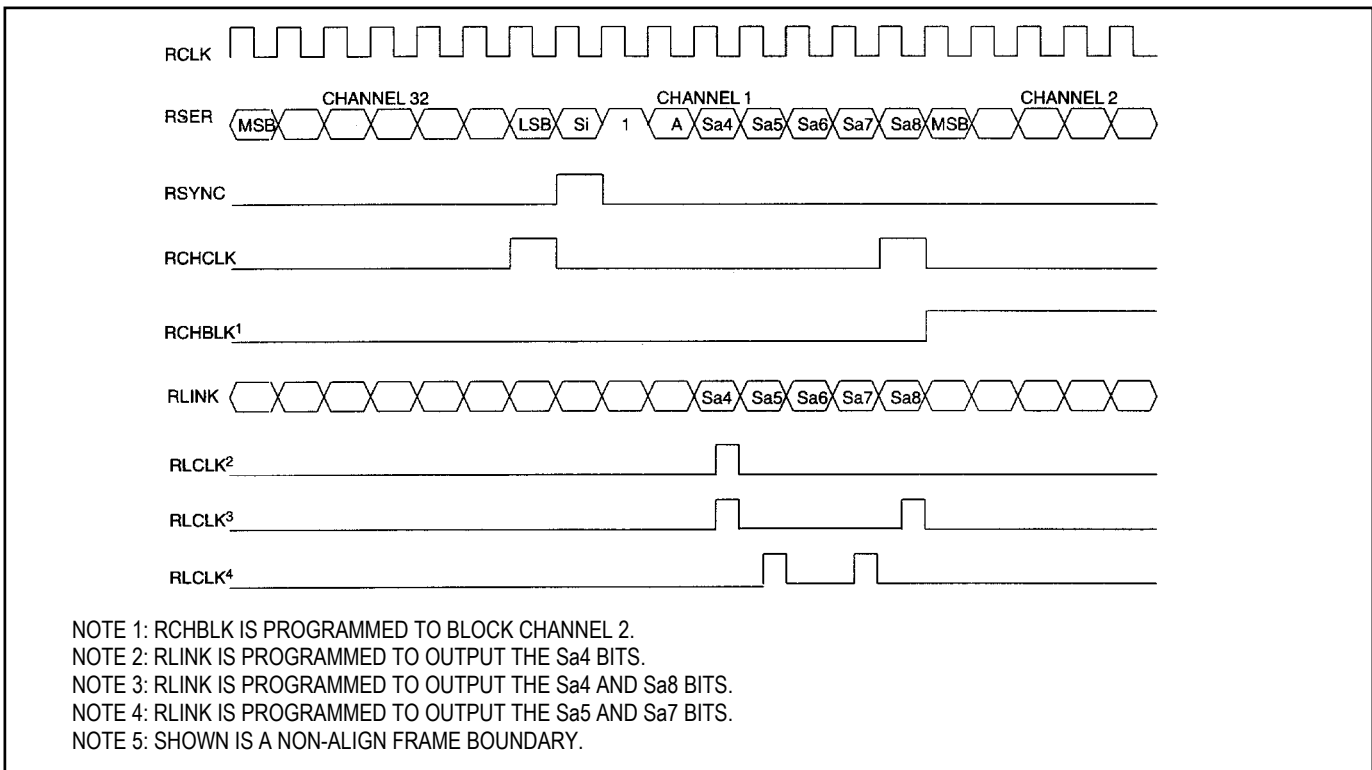
**Figure 13-4. Jitter Attenuation**

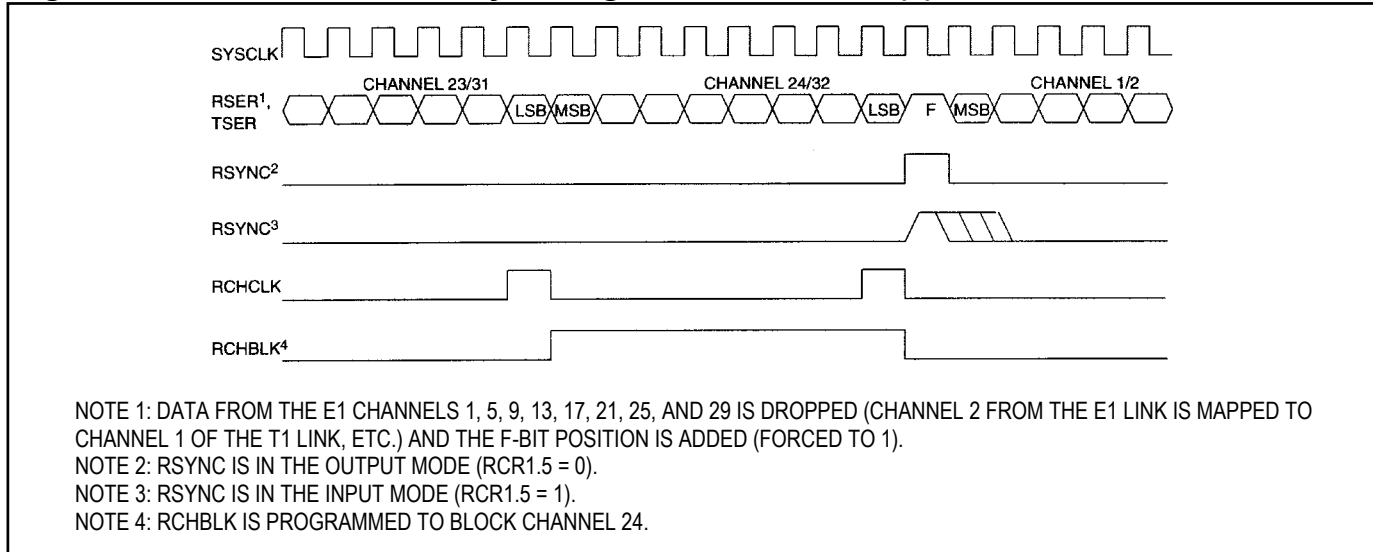
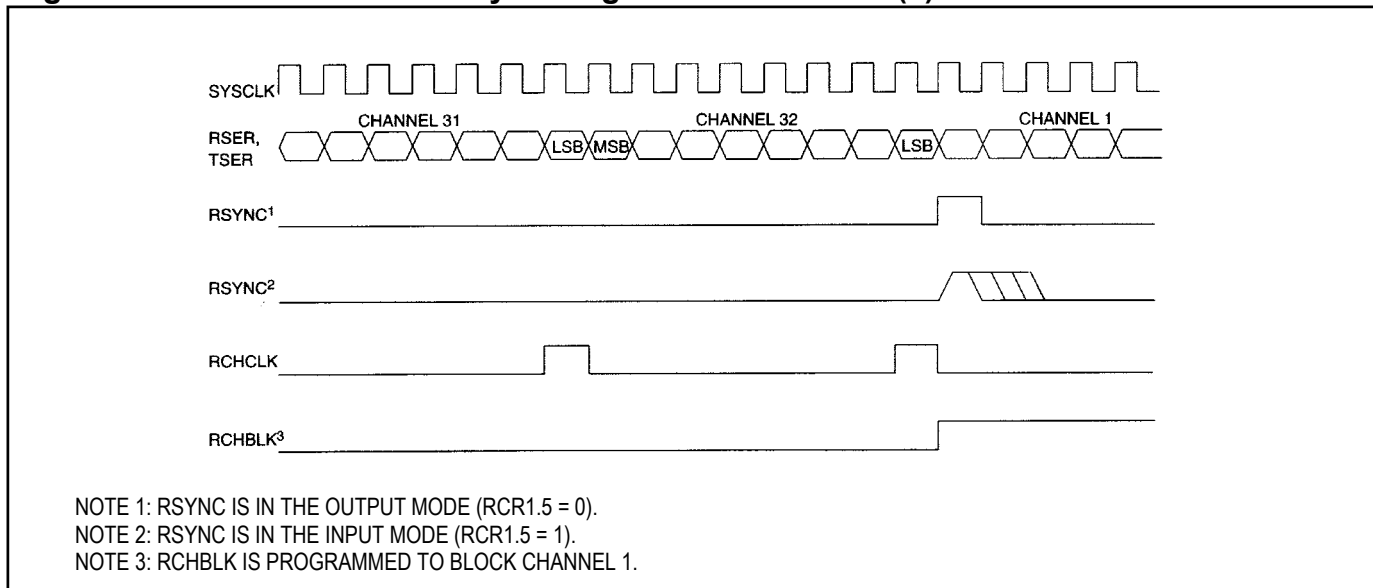
## 14 TIMING DIAGRAMS

**Figure 14-1. Receive Side Timing**

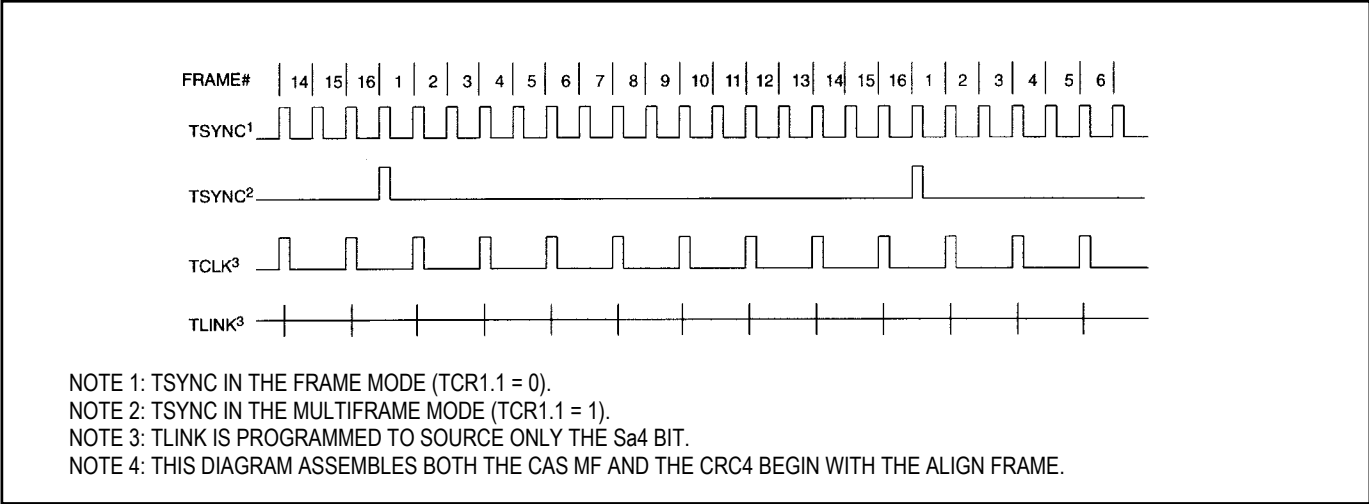


**Figure 14-2. Receive Side Boundary Timing (with Elastic Stores Disabled)**

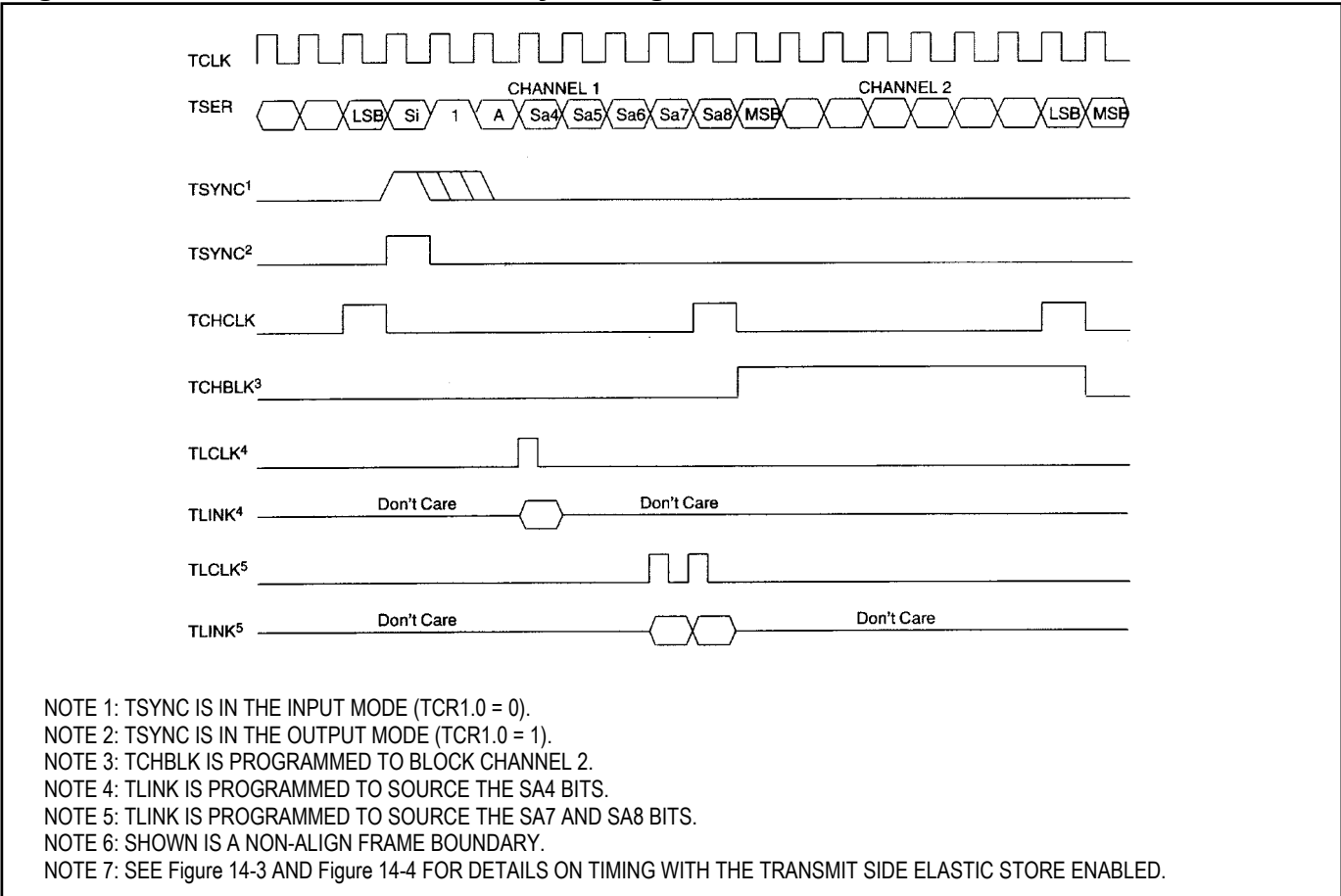


**Figure 14-3. 1.544MHz Boundary Timing with Elastic Store(s) Disabled**

**Figure 14-4. 2.048MHz Boundary Timing with Elastic Store(s) Enabled**


**Figure 14-5. Transmit Side Timing**



**Figure 14-6. Transmit Side Boundary Timing**





**Figure 14-7. G.802 Timing**

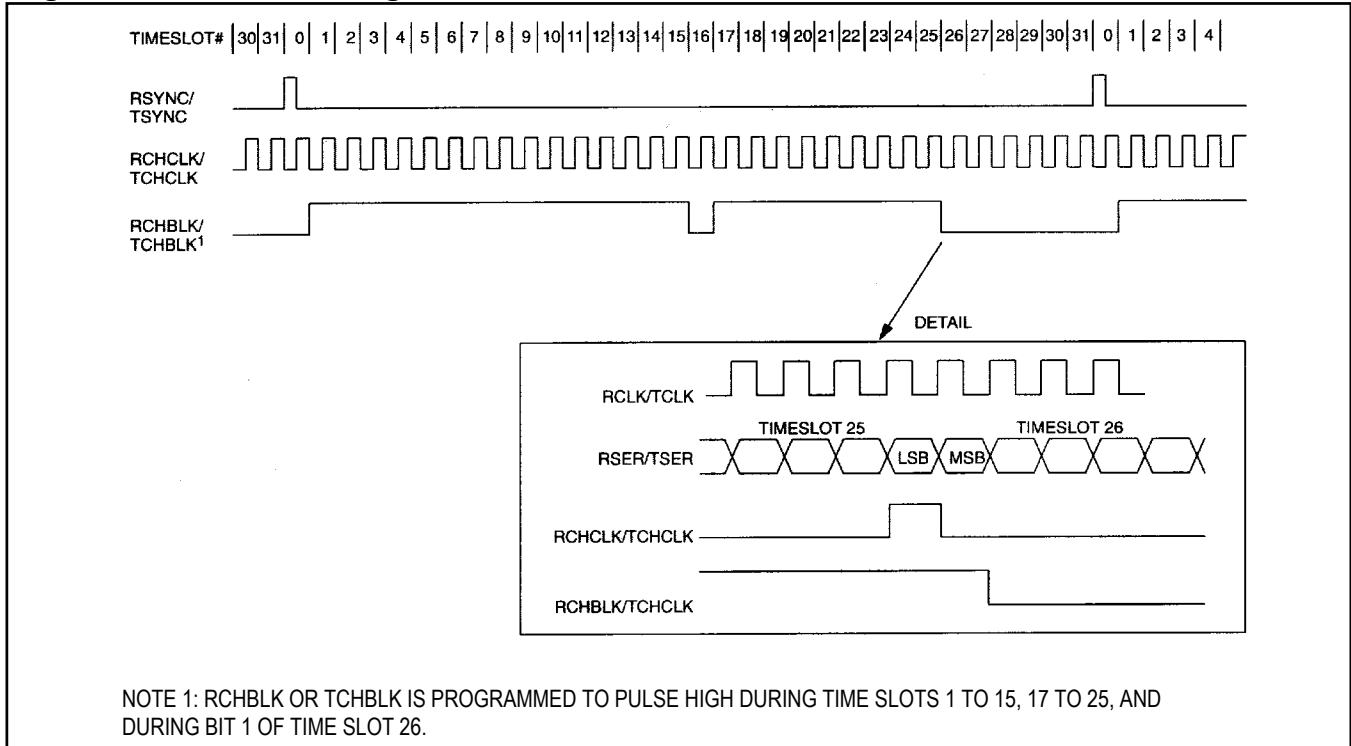


Figure 14-8. Synchronization Flowchart

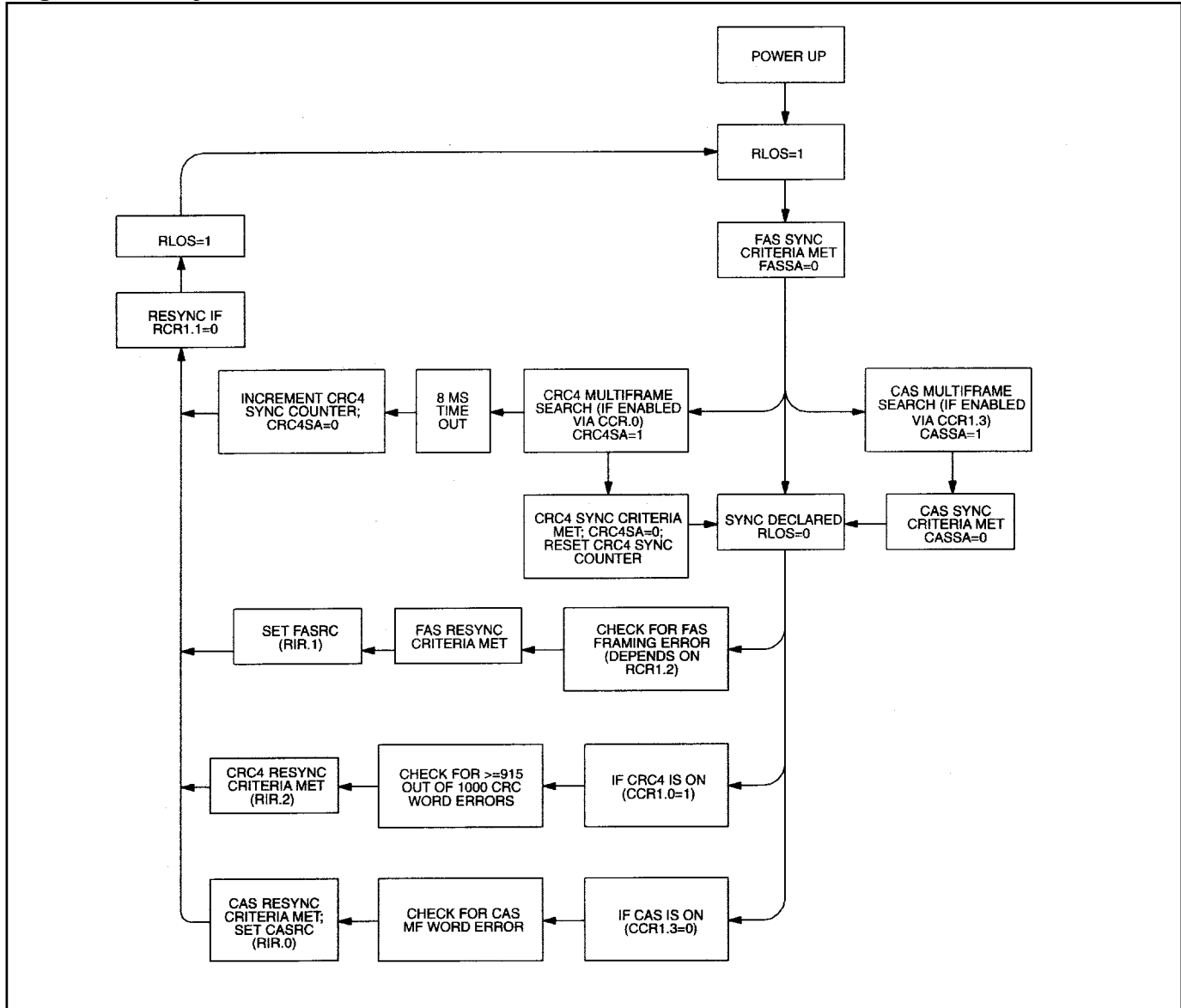
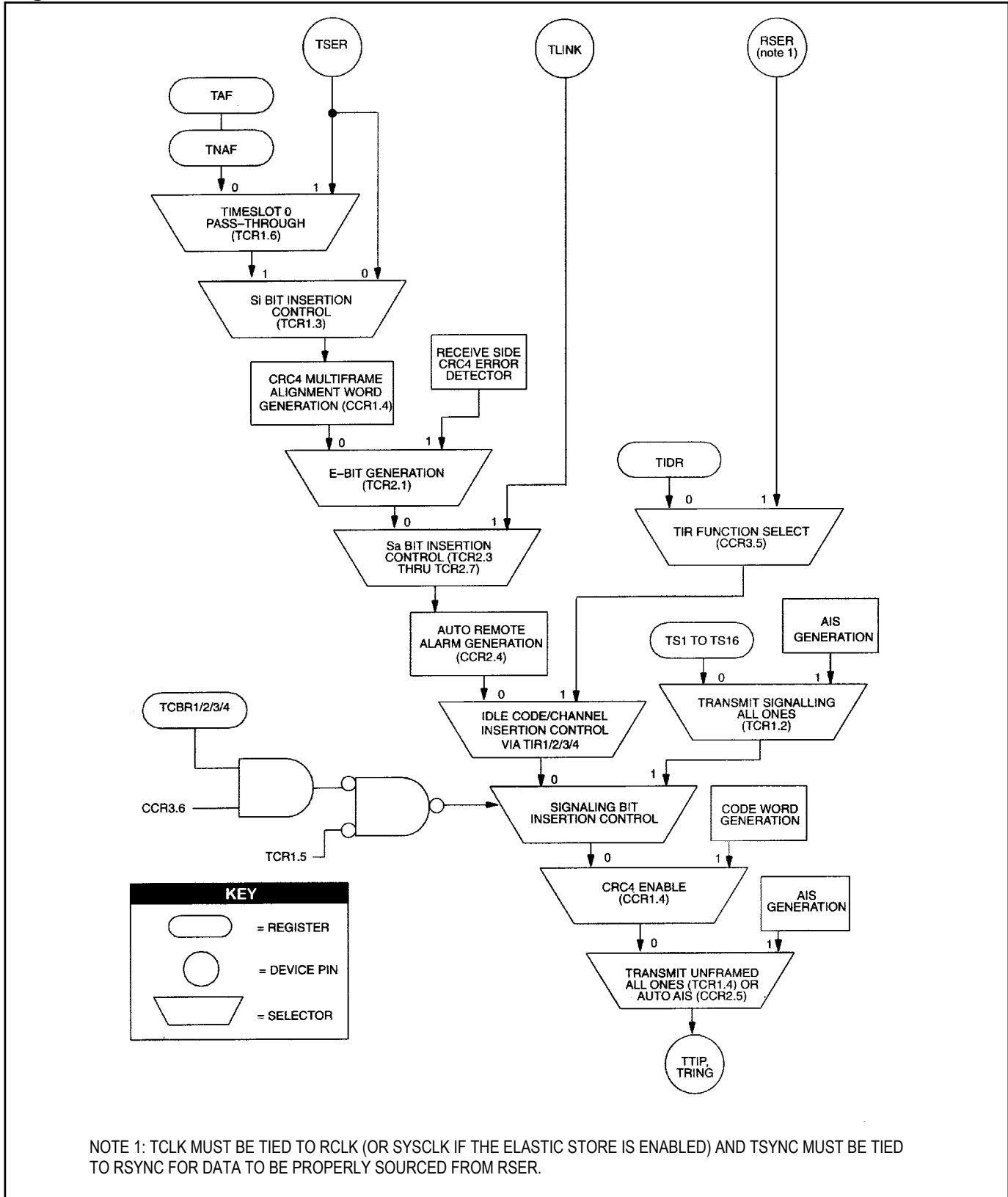


Figure 14-9. Transmit Data Flow



## 15 DC CHARACTERISTICS

### ABSOLUTE MAXIMUM RATINGS

Voltage Range on Any Pin Relative to Ground.....	-1.0V to +7.0V
Operating Temperature Range	
Commercial.....	0°C to 70°C
Industrial.....	-40°C to +85°C
Storage Temperature .....	-55°C to +125°C
Soldering Temperature.....	See IPC/JEDEC J-STD-020 Specification

*This is a stress rating only and functional operation of the device at these or any other conditions above those indicated in the operation sections of this specification is not implied. Exposure to absolute maximum rating conditions for extended periods of time may affect reliability.*

**Table 15-1. Recommended DC Characteristics**

( $T_A = 0^\circ\text{C}$  to  $+70^\circ\text{C}$  for DS2153Q,  $T_A = -40^\circ\text{C}$  to  $+85^\circ\text{C}$  for DS2153QN.)

PARAMETER		SYMBOL	MIN	TYP	MAX	UNITS	NOTES
Logic 1		$V_{IH}$	2.0		$V_{DD} + 0.3$	V	
Logic 0		$V_{IL}$	-0.3		+0.8	V	
Supply	DS2153Q	$V_{DD}$	4.75		5.25	V	1
	DS2153QN		4.80		5.25		

**Table 15-2. Capacitance**

( $T_A = +25^\circ\text{C}$ )

PARAMETER	SYMBOL	MIN	TYP	MAX	UNITS	NOTES
Input Capacitance	$C_{IN}$		5		pF	
Output Capacitance	$C_{OUT}$		7		pF	

**Table 15-3. DC Characteristics**

( $V_{DD} = 5V \pm 5\%$ ,  $T_A = 0^\circ\text{C}$  to  $+70^\circ\text{C}$  for DS2153Q;  $V_{DD} = 5V +5\%/-4\%$ ,  $T_A = -40^\circ\text{C}$  to  $+85^\circ\text{C}$  for DS2153QN.)

PARAMETER	SYMBOL	MIN	TYP	MAX	UNITS	NOTES
Supply Current at 5V	$I_{DD}$		65		mA	2
Input Leakage	$I_{IL}$	-1.0		+1.0	$\mu\text{A}$	3
Output Leakage	$I_{LO}$			1.0	$\mu\text{A}$	4
Output Current (2.4V)	$I_{OH}$	-1.0			mA	
Output Current (0.4V)	$I_{OL}$	+4.0			mA	

#### NOTES:

- 1) Applies to RVDD, TVDD, and DVDD.
- 2) TCLK = 2.048MHz.
- 3)  $0V < V_{IN} < V_{DD}$ .
- 4) Applies to  $\overline{\text{INT1}}$  and  $\overline{\text{INT1}}$  when tri-stated.

## 16 AC CHARACTERISTICS

**Table 16-1. AC Characteristics—Parallel Port**

( $V_{DD} = 5V \pm 5\%$ ,  $T_A = 0^\circ C$  to  $+70^\circ C$  for DS2153Q;  $V_{DD} = 5V +5\%/-4\%$ ,  $T_A = -40^\circ C$  to  $+85^\circ C$  for DS2153QN.) (See [Figure 16-1](#), [Figure 16-2](#), and [Figure 16-3](#).)

PARAMETER	SYMBOL	MIN	TYP	MAX	UNITS	NOTES
Cycle Time	$t_{CYC}$	250			ns	
Pulse Width, DS Low or $\overline{RD}$ High	$PW_{EL}$	150			ns	
Pulse Width, DS High or $\overline{RD}$ Low	$PW_{EH}$	100			ns	
Input Rise/Fall Times	$t_R, t_F$			30	ns	
$R/\overline{W}$ Hold Time	$t_{RWH}$	10			ns	
$R/\overline{W}$ Setup Time before DS High	$t_{RWS}$	50			ns	
$\overline{CS}$ Setup Time before DS, $\overline{WR}$ or $\overline{RD}$ Active	$t_{CS}$	20			ns	
$\overline{CS}$ Hold Time	$t_{CH}$	0			ns	
Read Data Hold Time	$t_{DHR}$	10		50	ns	
Write Data Hold Time	$t_{DHW}$	0			ns	
Muxed Address Valid to AS or ALE Fall	$t_{ASL}$	20			ns	
Muxed Address Hold Time	$t_{AHL}$	10			ns	
Delay Time DS, $\overline{WR}$ or $\overline{RD}$ to AS or ALE Rise	$t_{ASD}$	25			ns	
Pulse Width AS or ALE High	$PW_{ASH}$	40			ns	
Delay Time, AS or ALE to DS, $\overline{WR}$ or $\overline{RD}$	$t_{ASED}$	20			ns	
Output Data Delay Time from DS or $\overline{RD}$	$t_{DDR}$	20		100	ns	
Data Setup Time	$t_{DSW}$	80			ns	

Figure 16-1. Intel Bus Read AC Timing

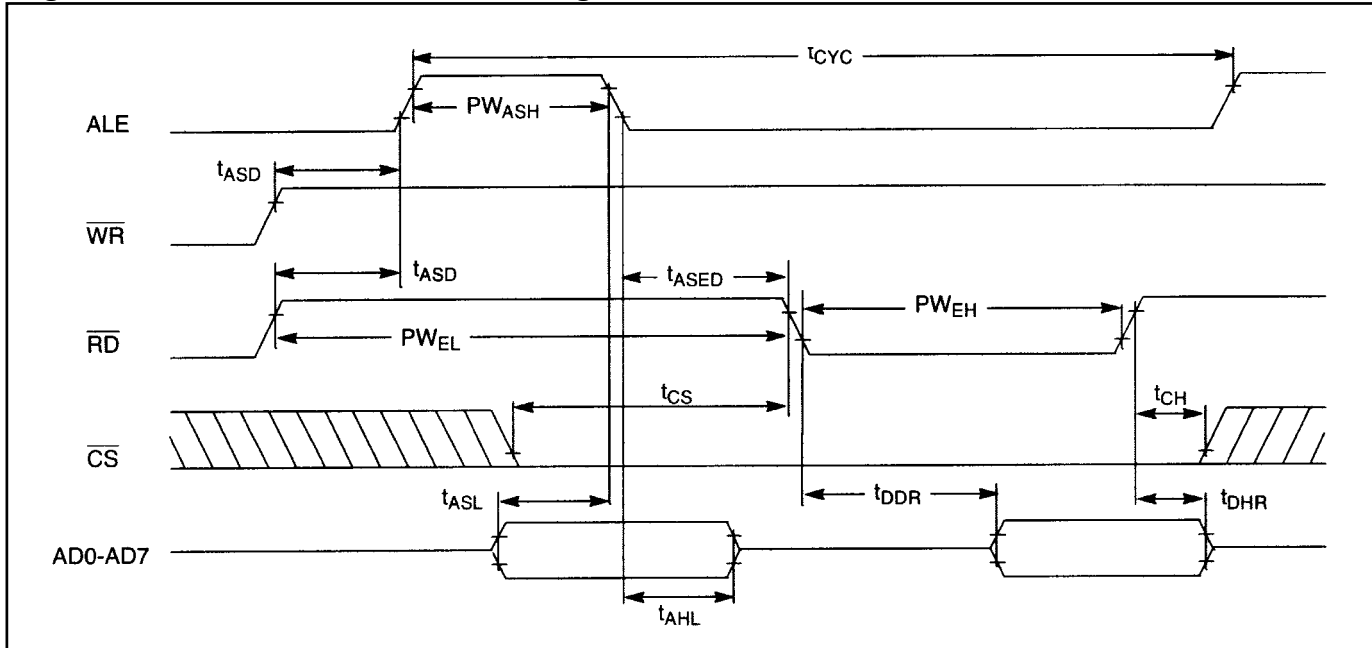


Figure 16-2. Intel Bus Write AC Timing

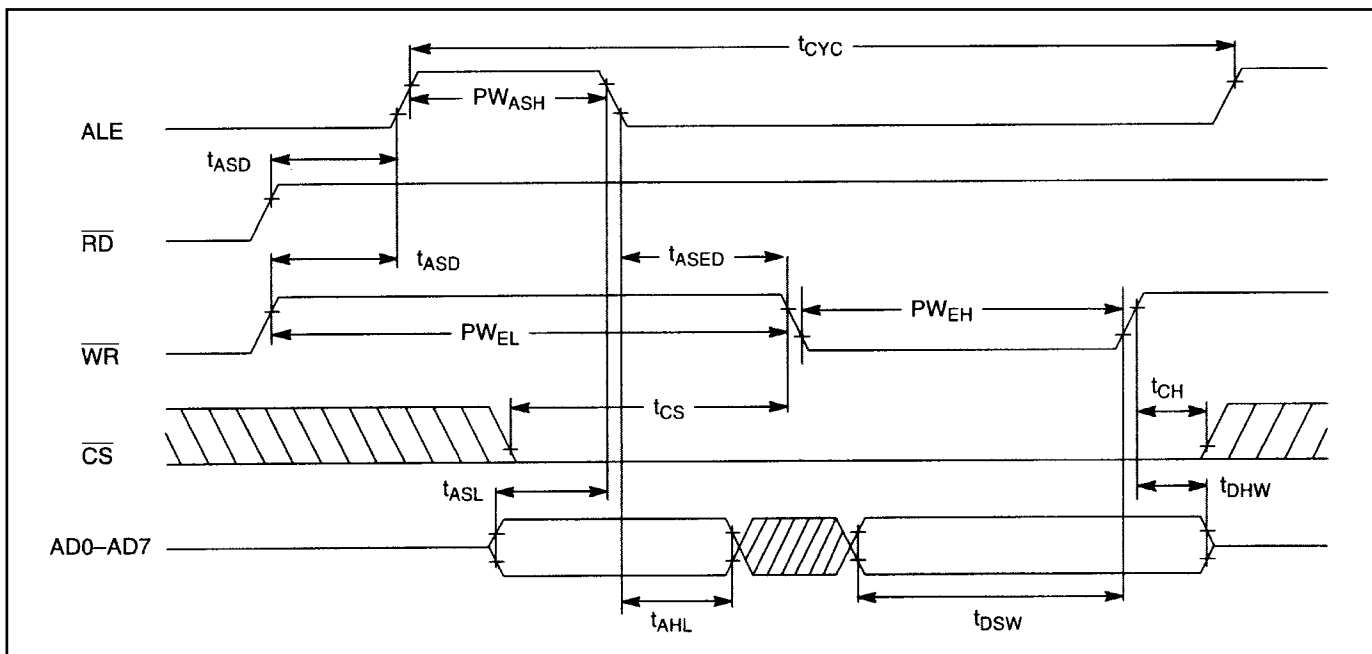
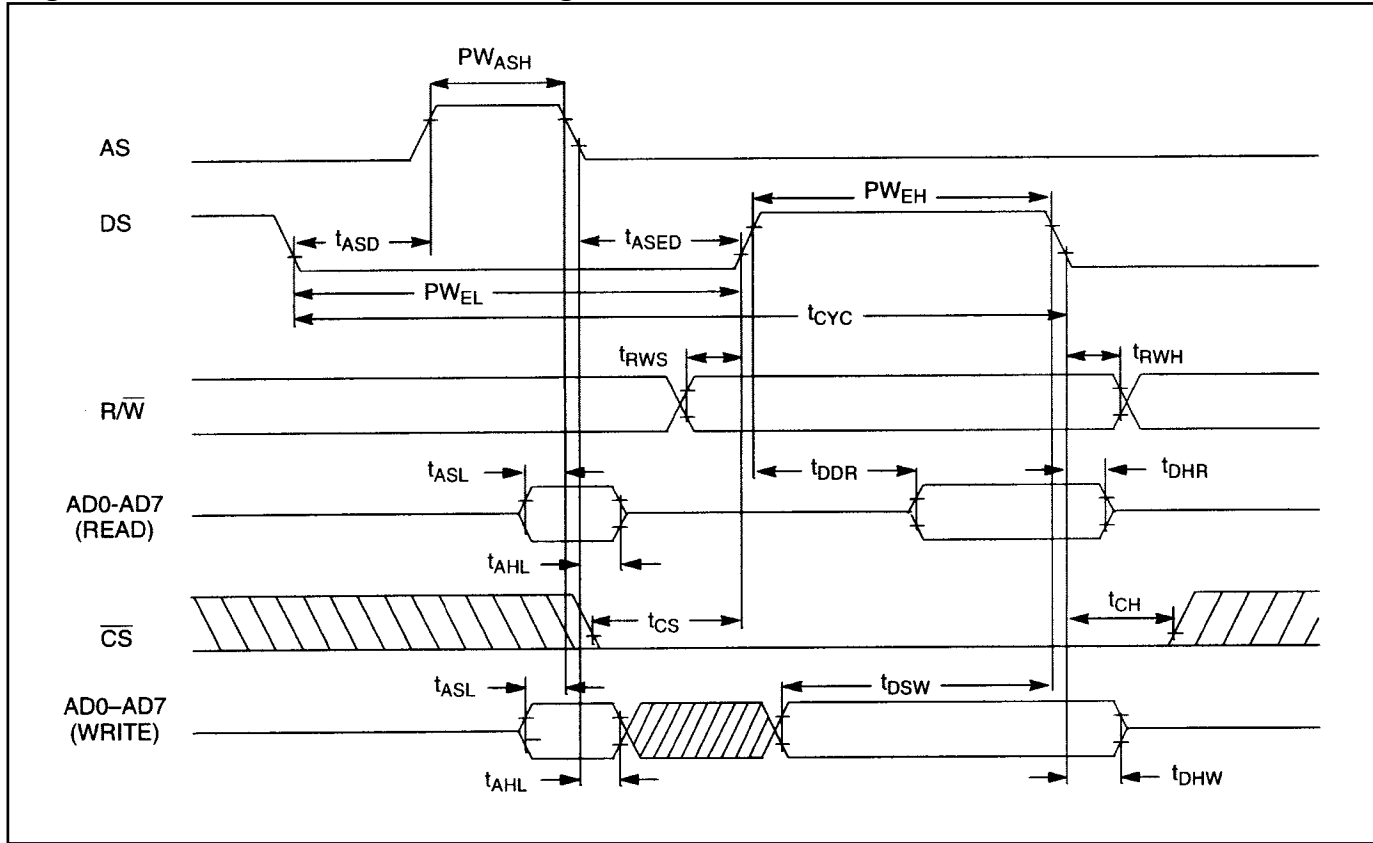


Figure 16-3. Motorola Bus AC Timing



**Table 16-2. AC Characteristics—Receive Side**

( $V_{DD} = 5V \pm 5\%$ ,  $T_A = 0^\circ C$  to  $+70^\circ C$  for DS2153Q;  $V_{DD} = 5V +5\%/-4\%$ ,  $T_A = -40^\circ C$  to  $+85^\circ C$  for DS2153QN.) (See [Figure 16-4](#).)

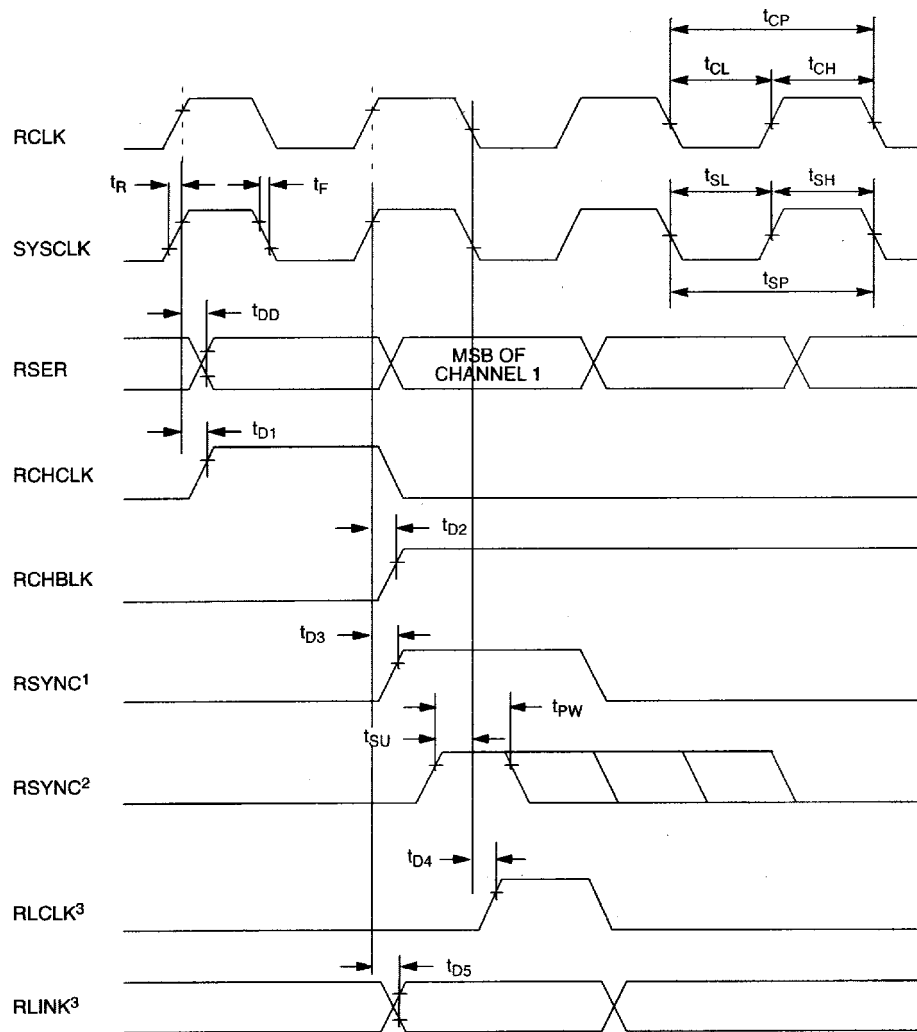
PARAMETER	SYMBOL	MIN	TYP	MAX	UNITS	NOTES
ACLKI/RCLK Period	$t_{CP}$		488		ns	
RCLK Pulse Width	$t_{CH}$	180	244		ns	1
	$t_{CL}$	180	244		ns	
RCLK Pulse Width	$t_{CH}$	90	244		ns	2
	$t_{CL}$	200	244		ns	
SYSCLK Period	$t_{SP}$		648		ns	3
	$t_{SP}$		488		ns	4
SYSCLK Pulse Width	$t_{SH}$	50			ns	
	$t_{SL}$	50				
RSYNC Setup to SYSCLK Falling	$t_{SU}$	25		$t_{SH} - 5$	ns	
RSYNC Pulse Width	$t_{PW}$	50			ns	
SYSCLK Rise/Fall Times	$t_R, t_F$			25	ns	
Delay RCLK or SYSCLK to RSER Valid	$t_{DD}$			70	ns	
Delay RCLK or SYSCLK to RCHCLK	$t_{D1}$			50	ns	
Delay RCLK or SYSCLK to RCHBLK	$t_{D2}$			50	ns	
Delay RCLK or SYSCLK to RSYNC	$t_{D3}$			50	ns	
Delay RCLK to RLCLK	$t_{D4}$			50	ns	
Delay RCLK to RLINK Valid	$t_{D5}$			50	ns	

**NOTES:**

- 1) Jitter attenuator enabled in the receive side path.
- 2) Jitter attenuator disabled or enabled in the transmit path.
- 3) SYSCLK = 1.544MHz.
- 4) SYSCLK = 2.048MHz.



Figure 16-4. Receive Side AC Timing



NOTE 1: RSYNC IS IN THE OUTPUT MODE (RCR1.5 = 0).

NOTE 2: RSYNC IS IN THE INPUT MODE (RCR1.5 = 1).

NOTE 3: RLCLK AND RLINK ONLY HAVE A TIMING RELATIONSHIP TO RCLK. NO TIMING RELATIONSHIP BETWEEN RLCLK/RLINK AND RSYNC IS IMPLIED.

NOTE 4: RCLK CAN EXHIBIT A SHORT HIGH TIME IF THE JITTER ATTENUATOR IS EITHER DISABLED OR IN THE TRANSMIT PATH.

**Table 16-3. AC Characteristics—Transmit Side**

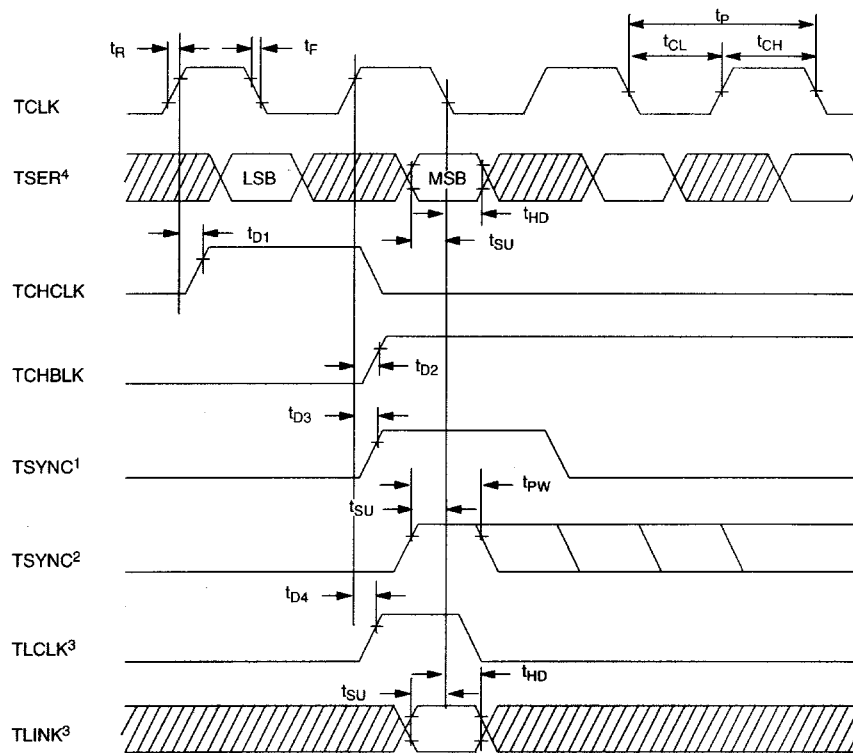
( $V_{DD} = 5V \pm 5\%$ ,  $T_A = 0^\circ\text{C}$  to  $+70^\circ\text{C}$  for DS2153Q;  $V_{DD} = 5V +5\%/-4\%$ ,  $T_A = -40^\circ\text{C}$  to  $+85^\circ\text{C}$  for DS2153QN.) (See [Figure 16-5](#).)

PARAMETER	SYMBOL	MIN	TYP	MAX	UNITS	NOTES
TCLK Period	$t_p$		488		ns	
TCLK Pulse Width	$t_{CH}$	75			ns	
	$t_{CL}$	75			ns	
TSER and TLINK Set up to TCLK Falling	$t_{SU}$	25			ns	1
TSER and TLINK Hold from TCLK Falling	$t_{HD}$	25			ns	1
TSYNC Set up to TCLK Falling	$t_{SU}$	25		$t_{CH} - 5$		
TSYNC Pulse Width	$t_{PW}$					
TCLK Rise/Fall Times	$t_R, t_F$			25	ns	
Delay TCLK to TCHCLK	$t_{D1}$			50	ns	
Delay TCLK to TCHBLK	$t_{D2}$			50	ns	
Delay TCLK to TSYNC	$t_{D3}$			50	ns	
Delay TCLK to TLCLK	$t_{D4}$			50	ns	

**NOTES:**

- 1) If the transmit side elastic store is enabled, then TSER is sampled on the falling edge of SYSCLK and the parameters  $t_{SU}$  and  $t_{HD}$  still apply.

Figure 16-5. Transmit Side AC Timing



NOTE 1: TSYNC IS IN THE OUTPUT MODE (TCR1.0 = 1).

NOTE 2: TSYNC IS IN THE INPUT MODE (TCR1.0 = 0).

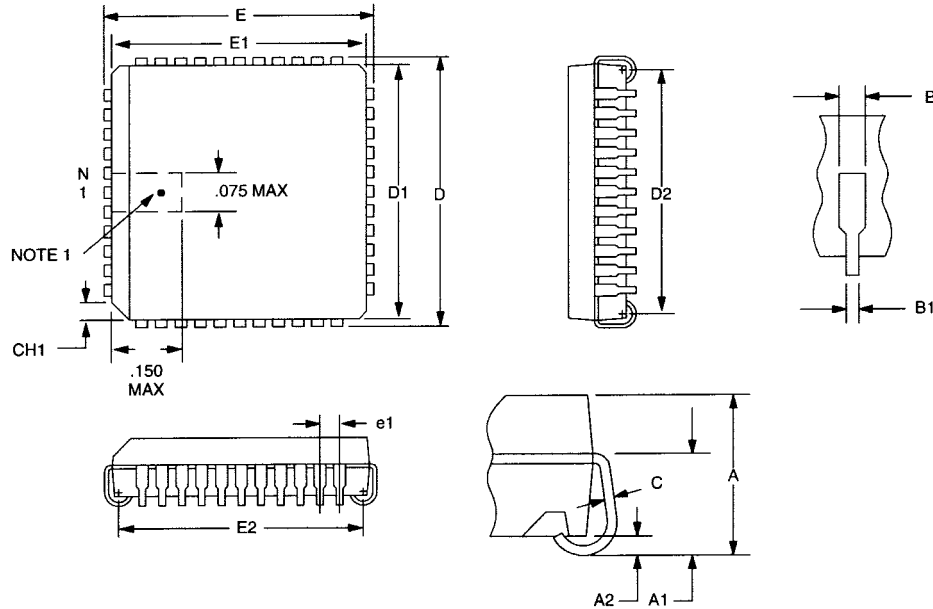
NOTE 3: NO TIMING RELATIONSHIP BETWEEN TSYNC AND TLCLK/TLINK IS IMPLIED.

NOTE 4: TSER IS SAMPLED ON THE FALLING EDGE OF TSYNC IF THE TRANSMIT SIDE ELASTIC STORE IS ENABLED.

## 17 PACKAGE INFORMATION

(The package drawing(s) in this data sheet may not reflect the most current specifications. The package number provided for each package is a link to the latest package outline information.)

### 17.1 44-Pin PLCC ([56-G4003-001](#))



NOTE1: PIN 1 IDENTIFIER TO BE LOCATED IN ZONE INDICATED.

DIM	INCHES	
	MIN	MAX
A	0.165	0.180
A1	0.090	0.120
A2	0.020	—
B	0.026	0.033
B1	0.013	0.021
C	0.009	0.012
CH1	0.042	0.048
D	0.685	0.695
D1	0.650	0.656
D2	0.590	0.630
E	0.685	0.695
E1	0.650	0.656
E2	0.590	0.630
e1	0.050 BSC	
N	44	—

Maxim/Dallas Semiconductor cannot assume responsibility for use of any circuitry other than circuitry entirely embodied in a Maxim/Dallas Semiconductor product. No circuit patent licenses are implied. Maxim/Dallas Semiconductor reserves the right to change the circuitry and specifications without notice at any time.

**Maxim Integrated Products, 120 San Gabriel Drive, Sunnyvale, CA 94086 408-737-7600**

© 2006 Maxim Integrated Products • Printed USA

The Maxim logo is a registered trademark of Maxim Integrated Products, Inc. The Dallas logo is a registered trademark of Dallas Semiconductor.