

# MDE Semiconductor, Inc.

78-150 Calle Tampico, Unit 210, La Quinta, CA, U.S.A. 92253 Tel: 760-564-8656 • Fax: 760-564-2414

## TWO TERMINAL THYRISTOR SERIES

### SURFACE MOUNT AND AXIAL LEAD TWO TERMINAL THYRISTOR (3T) SURGE SUPPRESSOR

#### FEATURES

- UL94V-O Fammability Classification
- ESD Protection >40 kilovolts
- Low Capacitance for T1/E1 Trunk and Line card applications
- High Surge Current Capability (See Electrical Characteristics)
- Peak Off-State Voltage from 58 to 300 volts
- Meet IEC100-4-4 & 5 Industry Requirement
- Provides Protection in Accordance with FCC Part 68, UL1459, Bellcore 189, ITU-TK, 20 & k. 21

#### DEVICE SYMBOL

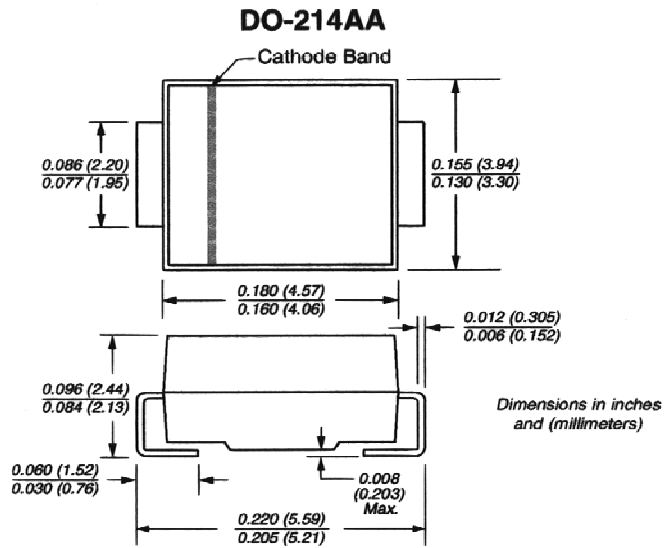
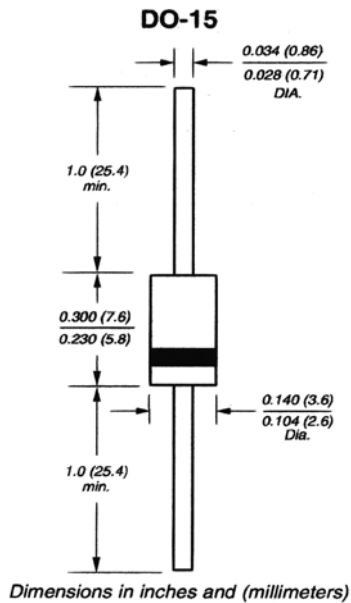
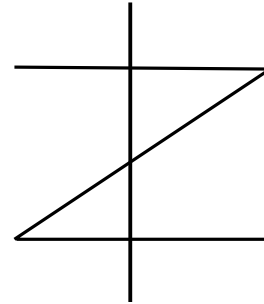

#### MECHANICAL DATA

Case: JEDEC DO-15 Molded plastic over glass passivated junction  
Terminals: Solder plated axial leads, solderable per MIL-STD-750, Method 2026  
Polarity: Color band denoted positive end (cathode) except Bipolar  
Mounting Position: Any  
Weight: 0.015 ounces, 0.4 grams

#### MECHANICAL DATA

Case: JEDEC DO214AA. Molded plastic over glass passivated junction  
Terminals: Solder plated, solderable per MIL-STD-750, Method 2026  
Polarity: Color band denoted positive end (cathode) except Bidirectional  
Standard Packaging: 12mm tape (EIA STD RS-481)  
Weight: 0.003 ounces, 0.093 grams

# MDE Semiconductor, Inc.

78-150 Calle Tampico, Unit 210, La Quinta, CA., USA 92253 Tel: 760-564-8656 • Fax: 760-564-2414

## Electrical Characteristics @ 25 °C Ambient Temperature

PART NUMBER	MARKING CODE FOR SMD PACKAGE	REPETITIVE PEAK OFF-STAGE VOLTAGE V <sub>DRM</sub> VOLTS	SWITCHING VOLTAGE @ 100V/ μs V <sub>s</sub> VOLTS	MINIMUM HOLDING CURRENT di/dt = 1A/ms I <sub>H</sub> mA	SWITCHING CURRENT I <sub>s</sub> mA	SURGE RATING I <sub>PP</sub> 10x1000 μs Amps	ON-STAGE CURRENT I <sub>T</sub> A	TYPICAL CAPACITANCE @ 2V, 1MHZ C pF
3T064A	GC	58.00	77	150	800.0	50.0	1	60
3T072A	GD	65.00	88	150	800.0	50.0	1	60
3T080A	GE	75.00	98	150	800.0	50.0	1	60
3T110A	GF	90.00	130	150	800.0	50.0	1	60
3T130A	GG	120.00	160	150	800.0	50.0	1	40
3T150A	GH	140.00	180	150	800.0	50.0	1	40
3T180A	GI	160.00	220	150	800.0	50.0	1	40
3T230A	GJ	190.00	260	150	800.0	50.0	1	30
3T260A	GK	220.00	300	150	800.0	50.0	1	30
3T310A	GL	275.00	350	150	800.0	50.0	1	30
3T350A	GM	300.00	400	150	800.0	50.0	1	30
3T064B	GP	58.00	77	150	800.0	100.0	1	60
3T072B	GQ	65.00	88	150	800.0	100.0	1	60
3T080B	GR	75.00	98	150	800.0	100.0	1	60
3T110B	GS	90.00	130	150	800.0	100.0	1	60
3T130B	GT	120.00	160	150	800.0	100.0	1	40
3T150B	GU	140.00	180	150	800.0	100.0	1	40
3T180B	GV	160.00	220	150	800.0	100.0	1	40
3T230B	GW	190.00	260	150	800.0	100.0	1	30
3T260B	GX	220.00	300	150	800.0	100.0	1	30
3T310B	GY	275.00	350	150	800.0	100.0	1	30
3T350B	GZ	300.00	400	150	800.0	100.0	1	30

**FIGURE 1  
PULSE WAVE FORM EXAMPLE**

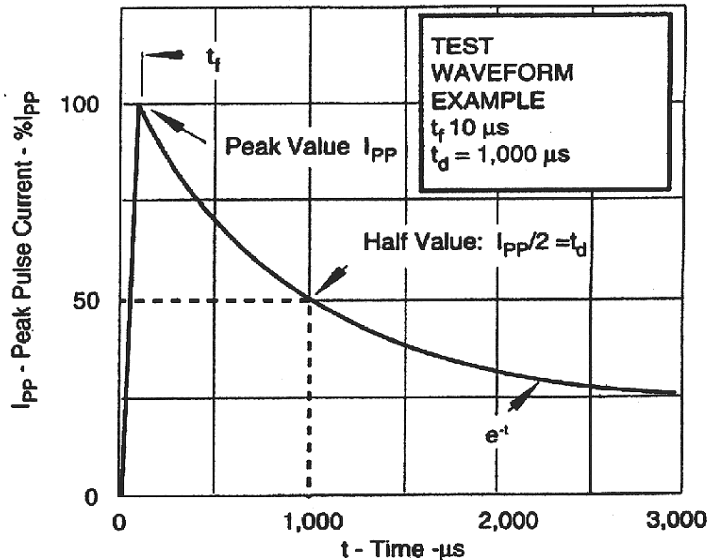

# MDE Semiconductor, Inc.

78-150 Calle Tampico, Unit 210, La Quinta, CA., USA 92253 Tel: 760-564-8656 • Fax: 760-564-2414

**FIGURE 2**  
TYPICAL PEAK OFF-STATE CURRENT VS JUNCTION TEMPERATURE

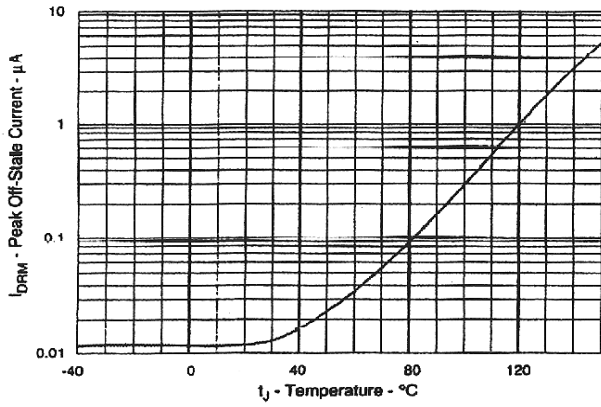

**FIGURE 3**  
TYPICAL ON-STATE CURRENT VS ON-STATE VOLTAGE

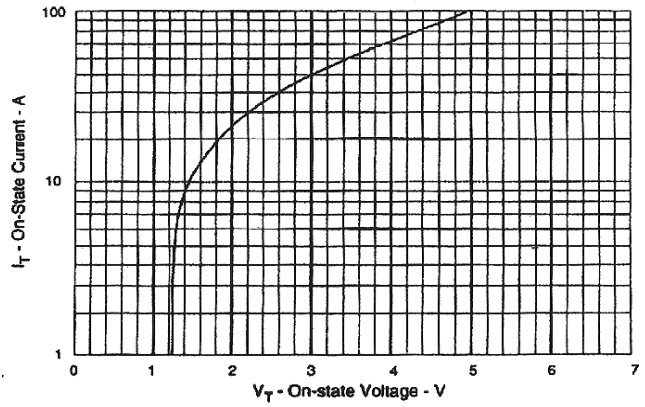

**FIGURE 4**  
TYPICAL HOLDING CURRENT VS JUNCTION TEMPERATURE

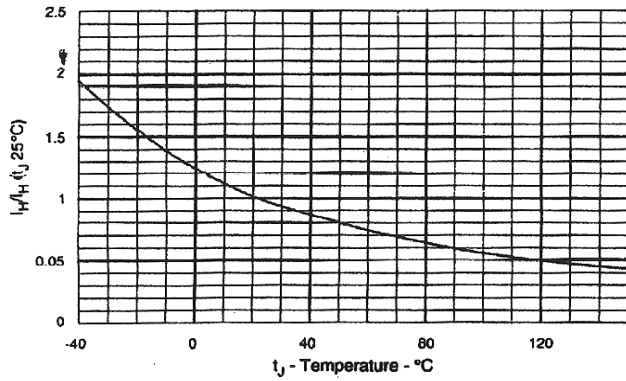

**FIGURE 5**  
TYPICAL NORMALIZED  $V_S$  VS JUNCTION TEMPERATURE

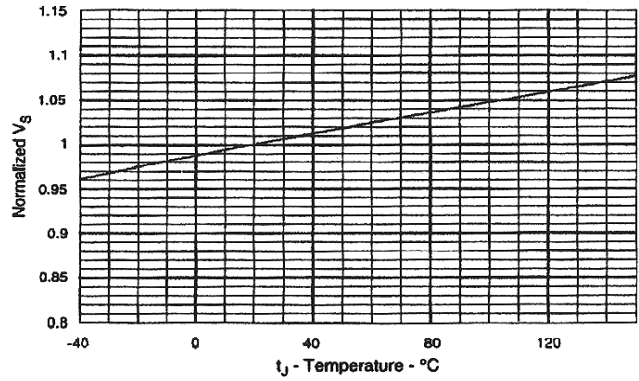

**FIGURE 6**  
ON-STATE CURRENT VS SURGE CURRENT DURATION

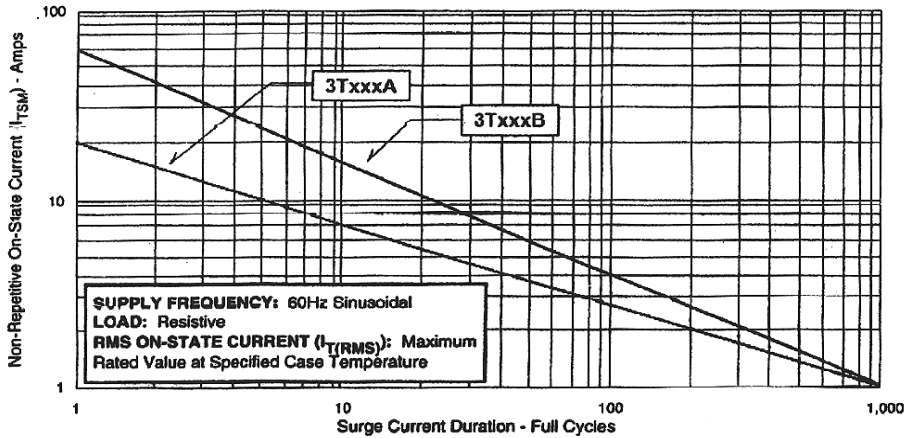

**FIGURE 7**  
V - I CHARACTERISTICS CURVE

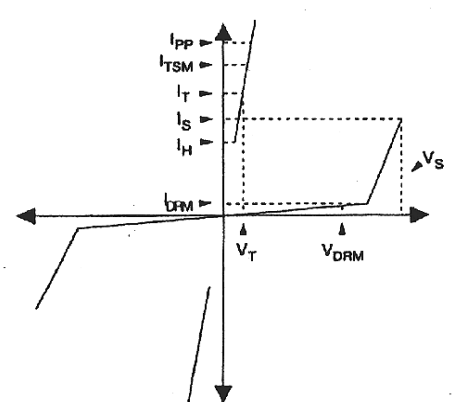

# MDE Semiconductor, Inc.

78-150 Calle Tampico, Unit 210, La Quinta, CA., USA 92253 Tel: 760-564-8656 • Fax: 760-564-2414

## Application Notes for Thyristor Surge Suppressors used in Telecommunication Circuits

FIGURE 8 - UL 1459 & FCC Part 68 Metallic Protection

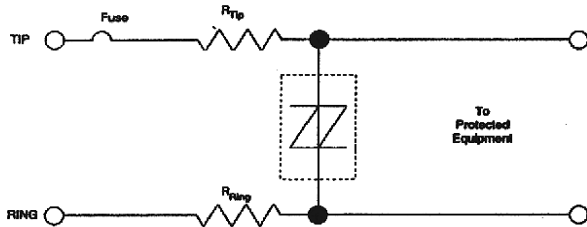

The 3T device is located across the tip-to-ring line after a limiting resistor and fuse combination. RTIP and RRING resistors are optional depending upon the 3T device selection. Without the resistors, the 3T310B is recommended. However, with a resistance value of 7.5 ohms for tip and ring, the 3T310A is recommended. Digital signals may use a lower 3T device depending upon the total tip to ring voltage range. Selection of the 3T device, either 3TXXXA or B is based upon the value of the tip and ring resistors. For the National Electronic Code (NEC) article 800, it is recommended that at least one fuse be used in the tip or ring line for metallic surges. Fuses may be replaced with a suitable Positive Temperature Coefficient (PTC) automatic resettable current limiting device.

FIGURE 9 - UL 1459 & FCC Part 68 - Longitudinal Protection

There are two 3T devices, one located from tip-to-ground and one ring-to-ground. For standard analog signals, the 3T310A is recommended with a typical resistor value for tip and ring of 15 ohms. The 3T310B is recommended for resistor values of 7.5 ohms each. The National Electronic Code (NEC) article 800 requires two fuse elements when connecting to ground. Fuses or a suitable Positive Temperature Coefficient (PTC) automatic resettable current limiting device may be used. The purpose of this circuit is to limit AC power current from getting on the ground line causing any safety hazard.

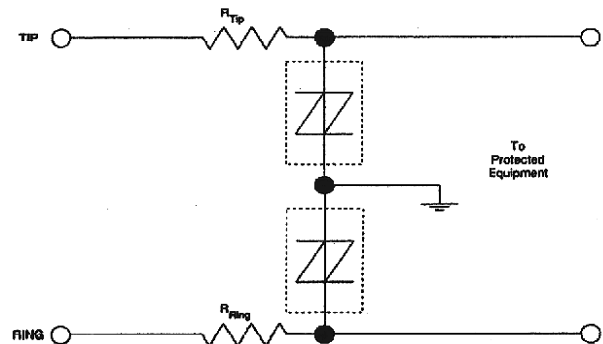
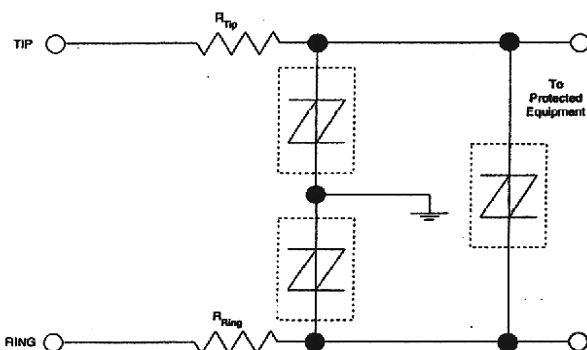

FIGURE 10 - UL 1459 & FCC Part 68 - Metallic and Longitudinal Protection



Three equal 3T devices are used in this application for metallic (tip-to-ring) and longitudinal (tip-to-ground and ring-to-ground) protection. For analog signals, the 3T310B is recommended. With a resistance value of 15 ohms for the tip and ring resistors, the 3T310A may be used. The National Electric Code (NEC) article 800 requires two fuse elements when connecting to ground. Fuses or a suitable Positive Temperature Coefficient (PTC) automatic resettable current limiting device may be used. This circuit is recommended for protection against the Bellcore requirement: First Level Lightning Surge Tests (Telecommunications Port), document # GR-1089-CORE.