



MicroConverter, Dual 10-channel 24-Bit ADCs with Embedded 62kB FLASH MCU

Preliminary Technical Data

ADuC845

FEATURES

High Resolution Sigma-Delta ADCs

Two Independent ADCs (24-Bit Resolution)

Up to 10 ADC input channels

24-Bit No Missing Codes, Primary ADC

20-Bit rms (17.4 Bit p-p) Effective Resolution @ 60 Hz

Offset Drift 10 nV/°C, Gain Drift 0.5 ppm/°C (Chop enabled)

Memory

62 Kbytes On-Chip Flash/EE Program Memory

4 Kbytes On-Chip Flash/EE Data Memory

Flash/EE, 100 Year Retention, 100 Kcycles Endurance

3 Levels of Flash/EE Program Memory Security

In-Circuit Serial Download (No External Hardware)

High Speed User Download (5 Seconds)

2304 Bytes On-Chip Data RAM

8051-Based Core

8051 Compatible Instruction Set

High Performance Single Cycle Core

32 kHz External Crystal

On-Chip Programmable PLL (12.58 MHz Max)

3 x 16-Bit Timer/Counter

26 Programmable I/O Lines

11 Interrupt Sources, Two Priority Levels

Dual Data Pointer, Extended 11-Bit Stack Pointer

On-Chip Peripherals

Internal Power on Reset Circuit

12-Bit Voltage Output DAC

Dual 16-Bit S-D DACs/PWMs

On-Chip Temperature Sensor

Dual Excitation Current Sources

Time Interval Counter (Wakeup/RTC Timer)

UART, SPI®, and I²C® Serial I/O

High Speed Baud Rate Generator (incl 115,200)

Watchdog Timer (WDT)

Power Supply Monitor (PSM)

Power

Normal: 2.3mA Max @ 3.6 V (Core CLK = 1.57 MHz)

Power-Down: 20mA Max with Wakeup Timer Running

Specified for 3 V and 5 V Operation

Package and Temperature Range

52-Lead MQFP (14 mm x 14 mm), -40°C to +125°C

56-Lead CSP (8 mm x 8 mm), -40°C to +85°C

APPLICATIONS

Multi channel Sensor monitoring

Industrial/Environmental Instrumentation

WeighScales

Portable Instrumentation, Battery Powered Systems

4-20mA Transmitters

Data Logging

Precision System Monitoring

FUNCTIONAL BLOCK DIAGRAM

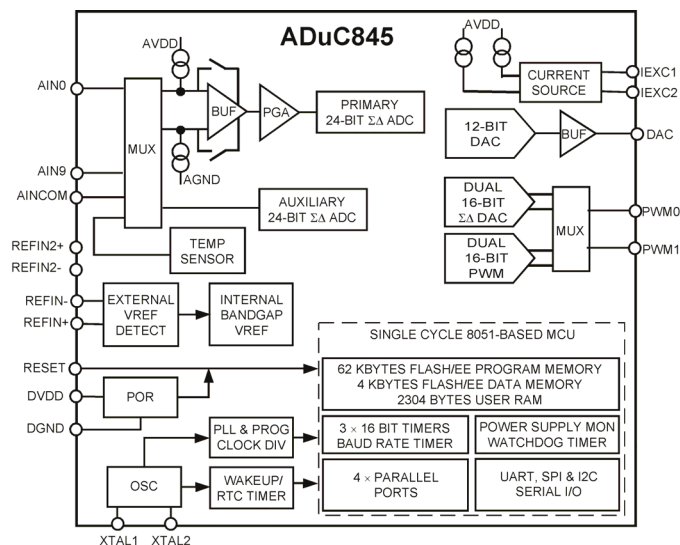

REV. PrB

Information furnished by Analog Devices is believed to be accurate and reliable. However, no responsibility is assumed by Analog Devices for its use, nor for any infringements of patents or other rights of third parties that may result from its use. No license is granted by implication or otherwise under any patent or patent rights of Analog Devices. Trademarks and registered trademarks are the property of their respective companies.

Purchase of licensed I²C components of Analog Devices or one of its sublicensed Associated Companies conveys a license for the purchaser under the Philips I²C Patent Rights to use these components in an I²C system, provided that the system conforms to the I²C Standard Specification as defined by Philips

One Technology Way, P.O. Box 9106, Norwood, MA 02062-9106, U.S.A.

Tel: 781/329-4700

www.analog.com

Fax: 781/326-8703

© 2003 Analog Devices, Inc. All rights reserved

Preliminary Technical Data

SPECIFICATIONS¹

ADuC845

(AVDD = 2.7 V to 3.6 V or 4.75 V to 5.25 V, DVDD = 2.85 V to 3.6 V or 4.75 V to 5.25 V, REFIN(+) = 2.5 V, REFIN(-) = AGND; AGND = DGND = 0 V; XTAL1/XTAL2 = 32.768 kHz Crystal; all specifications T_{MIN}, to T_{MAX} unless otherwise noted.).

PARAMETER	MIN	TYP	MAX	UNITS	CONDITION
PRIMARY ADC (CHOP ENABLED)¹					
Conversion Rate	5.4	19.8	105	Hz	On Both Channels
No Missing Codes ²	24			Bits	19.79Hz Update Rate
Resolution		13.5		Bits Pk-Pk	Range = ± 20mV, 20Hz Update Rate
		18.5		Bits Pk-Pk	Range = ± 2.56V, 20Hz Update Rate
		17.4		Bits Pk-Pk	Range = ± 2.56V, 59.4Hz Update Rate
Output Noise	See Tables V and VI in ADC Description				Output Noise varies with selected Update Rates and Gain Range
Integral Non Linearity			± 15	ppm of FSR	1 LSB ₁₆
Offset Error ³		± 3		μV	
Offset Error Drift (vs. Temp)		± 10		nV/°C	
Full-Scale Error ⁴		± 10		μV	
Gain Error Drift (vs. Temp) ⁵		± 0.5		ppm/°C	
ADC Range Matching		± 2		μV	AIN=18mV
Power Supply Rejection	80			dBs	AIN=1V, Range=± 2.56V
		113		dBs	AIN=7.8mV, Range=± 20mV
Common Mode DC Rejection					
On AIN	95			dBs	@DC, AIN=7.8mV, Range=± 20mV
On AIN		113		dBs	@DC, AIN=1V, Range=± 2.56V
Common Mode 50/60Hz Rejection					20 Hz Update Rate
On AIN	95			dBs	50/60Hz ± 1Hz, AIN=7.8mV, Range=± 20mV
On AIN	90			dBs	50/60Hz ± 1Hz, AIN=1V, Range=± 2.56V
Normal Mode 50/60 Hz Rejection					
On AIN	60			dBs	50/60Hz ± 1Hz, 20 Hz Update Rate

Preliminary Technical Data

ADuC845

PARAMETER	MIN	TYP	MAX	UNITS	CONDITION
PRIMARY ADC (CHOP DISABLED)¹					
Conversion Rate	16.06		1365	Hz	On Both Channels
No Missing Codes ²	24			Bits	59.36Hz Update Rate
Resolution		13		Bits Pk-Pk	Range = ± 20mV, 59.4Hz Update Rate
		18		Bits Pk-Pk	Range = ± 2.56V, 59.4Hz Update Rate
Output Noise	See Tables VII and VIII in ADC Description				Output Noise varies with selected Update Rates and Gain Range
Integral Non Linearity			± 15	ppm of FSR	1 LSB ₁₆
Offset Error ³		TBD			
Offset Error Drift (vs. Temp)		± 200		nV/°C	
Full-Scale Error ⁴		± 10		µV	
Gain Error Drift ⁵ (vs. Temp)		± 0.5		ppm/°C	
Negative Full-Scale Error			± 0.003	%FSR	
Power Supply Rejection	80			dBs	AIN=1V, Range=± 2.56V
		113		dBs	AIN=7.8mV, Range=± 20mV
Common Mode DC Rejection					
On AIN	95			dBs	@DC, AIN=7.8mV, Range=± 20mV
On AIN		113		dBs	@DC, AIN=1V, Range=± 2.56V
Common Mode 50/60Hz Rejection					59.4 Hz Update Rate
On AIN	95			dBs	50/60Hz ± 1Hz, AIN=7.8mV, Range=± 20mV
On AIN	90			dBs	50/60Hz ± 1Hz, AIN=1V, Range=± 2.56V
Normal Mode 50/60 Hz Rejection					
On AIN	60			dBs	50/60Hz ± 1Hz, 59.4 Hz Update Rate
PRIMARY ADC ANALOG INPUTS (CHOP DISABLED)					
Differential Input Voltage Ranges ^{9, 10}	± 1.024 x V _{REF} /GAIN			V	V _{REF} = REFIN(+) - REFIN(-) (or Int 1.25V Ref)
Bipolar Mode (ADC0CON.5 = 0)					GAIN = 1 to 128
Unipolar Mode (ADC0CON.5 = 1)	0 → 1.024 x V _{ref} /GAIN			V	V _{REF} = REFIN(+) - REFIN(-)
					GAIN=1 to 128
Analog Input Current ²			± 1	nA	T _{MAX} = 85°C
			± 5	nA	T _{MAX} = 125°C
Analog Input Current Drift		± 5		pA/°C	T _{MAX} = 85°C
		± 15		pA/°C	T _{MAX} = 125°C
AINCOM Input Current		± 125		nA/V	± 2.56V Range
AINCOM Input Current Drift		± 2		pA/V/°C	
Absolute AIN Voltage Limits ²	A _{GND} + 0.1		A _{VDD} - 0.1	V	
Absolute AINCOM Voltage Limits	A _{GND} + 0.03		A _{VDD} - 0.03	V	
EXTERNAL REFERENCE INPUTS (CHOP DISABLED)					
REFIN(+) to REFIN(-) Range ²	1	2.5	A _{VDD}	V	
Average Reference Input Current		1		µA/V	Both ADCs Enabled
Average Reference Input Current Drift		+/- 0.1		nA/V/°C	
'NO Ext. REF' Trigger Voltage	0.3		0.65	V	NOXREF bit active if VREF<0.3V
					NOXREF bit Inactive if VREF>0.65
Common Mode DC Rejection	125			dBs	@DC, AIN=1V, Range=± 2.56V
Common Mode 50/60Hz Rejection	90			dBs	50/60Hz ± 1Hz, AIN=1V, Range=± 2.56V
Normal Mode 50/60 Hz Rejection	60			dBs	50/60Hz ± 1Hz, 59.4 Hz Update Rate

PARAMETER	MIN	TYP	MAX	UNITS	CONDITION
AUXILIARY ADC (CHOP ENABLED)					
Conversion Rate	5.4	19.8	105	Hz	On Both Channels
No Missing Codes ²	24			Bits	20 Hz Update Rate
Resolution		16		Bits Pk-Pk	Range = ± 2.5V, 20Hz Update Rate
Output Noise		See Table IX Auxiliary ADC			Output Noise varies with selected Update Rates
Integral Non Linearity			± 15	ppm of FSR	1 LSB ₁₆
Offset Error ³		-2		LSB	
Offset Error Drift		1		µV /°C	
Fullscale Error ⁴		-2.5		LSBs	
Gain Error Drift ⁵		± 0.5		ppm/°C	
Power Supply Rejection	80			dBs	AIN=1V, Range=± 2.56V
Normal Mode 50/60 Hz Rejection					
On AIN	60			dBs	50/60Hz ± 1Hz, 19.79Hz Update Rate
On REFIN	60			dBs	50/60Hz ± 1Hz, 19.79Hz Update Rate
AUXILIARY ADC ANALOG INPUTS (CHOP ENABLED)					
Differential Input Voltage Ranges ^{9, 10} (Bipolar Mode – ADC0CON3 = 0)		± REFIN		V	REFIN=REFIN(+)-REFIN(-) (or Int 1.25V Ref)
(Unipolar Mode – ADC0CON3 = 1)		0 → REFIN		V	REFIN=REFIN(+)-REFIN(-) (or Int 1.25V Ref)
Average Analog Input Current		125		nA/V	
Analog Input Current Drift		± 2		pA/V/°C	
AINCOM Input Current		± 125		nA/V	± 2.56V Range
AINCOM Input Current Drift		± 2		pA/V/°C	
Absolute AIN/AINCOM Voltage Limits ^{2,11}	A _{GND} -0.03		A _{VDD} +0.03	V	
AUXILIARY ADC (CHOP DISABLED)					
Conversion Rate	16.06		1365	Hz	On Both Channels
No Missing Codes ²	24			Bits	20 Hz Update Rate
Resolution		16		Bits Pk-Pk	Range = ± 2.5V, 20Hz Update Rate
Output Noise		See Table IX Auxiliary ADC			Output Noise varies with selected Update Rates
Integral Non Linearity			± 15	ppm of FSR	1 LSB ₁₆
Offset Error		-2		LSB	
Offset Error Drift		1		µV /°C	
Fullscale Error ⁴		-2.5		LSBs	
Gain Error Drift ⁵		± 0.5		ppm/°C	
Power Supply Rejection	80			dBs	AIN=1V, Range=± 2.56V
Normal Mode 50/60 Hz Rejection					
On AIN	60			dBs	50/60Hz ± 1Hz, 19.79Hz Update Rate
On REFIN	60			dBs	50/60Hz ± 1Hz, 19.79Hz Update Rate
AUXILIARY ADC ANALOG INPUTS (CHOP DISABLED)					
Differential Input Voltage Ranges ^{9, 10} (Bipolar Mode – ADC0CON3 = 0)		± Vref		V	Vref=REFIN(+)-REFIN(-) (or Int 1.25V Ref)
(Unipolar Mode – ADC0CON3 = 1)		0 → Vref		V	Vref=REFIN(+)-REFIN(-) (or Int 1.25V Ref)
Average Analog Input Current		125		nA/V	
Analog Input Current Drift		± 2		pA/V/°C	
AINCOM Input Current		± 125		nA/V	± 2.56V Range
AINCOM Input Current Drift		± 2		pA/V/°C	
Absolute AIN/AINCOM Voltage Limits ^{2,11}	A _{GND} -0.03		A _{VDD} +0.03	V	

Preliminary Technical Data

ADuC845

PARAMETER	MIN	TYP	MAX	UNITS	CONDITION
ADC SYSTEM CALIBRATION					
Full Scale Calibration Limit			+1.05 x FS	V	
Zero Scale Calibration Limit	-1.05 x FS			V	
Input Span	0.8 x FS		2.1 x FS	V	
DAC					
Voltage Range		0 → V _{REF} 0 → AV _{DD}		V	DACCON.2 = 0 DACCON.2 = 1
Resistive Load		10		kΩ	From DAC Output to AGND
Capacitive Load		100		pF	From DAC Output to AGND
Output Impedance		0.5		Ω	
I _{SINK}		50		μA	
DC Specifications⁷					
Resolution	12			LSBs	Guaranteed 12-Bit Monotonic
Relative Accuracy		± 3		Bit	
Differential NonLinearity			-1	Bit	
Offset Error			± 50	mV	
Gain Error ⁸			± 1	%	AV _{DD} Range
		± 1		%	V _{REF} Range
AC Specifications^{2,7}					
Voltage Output Settling Time		15		us	Settling time to 1LSB of final value
Digital to Analog Glitch Energy		10		nVs	1 LSB change at major carry
INT REFERENCE (CHOP ENABLED)					
ADC Reference					
Reference Voltage	1.237	1.25	1.2625	V	initial tolerance @ 25°C, VDD=5V
Power Supply Rejection		45		dBs	
Reference Tempco		100		ppm/°C	
DAC Reference					
Reference Voltage	2.475	2.5	1.525	V	initial tolerance @ 25°C, VDD=5V
Power Supply Rejection		50		dBs	
Reference Tempco		± 100		ppm/°C	
TEMPERATURE SENSOR					
Accuracy		+/- 2		°C	MQFP Package CSP Package
Thermal Impedance		90		°C/W	
		52		°C/W	
TRANSDUCER BURNOUT CURRENT SOURCES					
AIN+ Current		-100		nA	AIN+ is the selected positive input (Ain4 or Ain6 only) to the primary ADC AIN- is the selected negative input (Ain5 or Ain7 only) to the primary ADC
AIN- Current		100		nA	
Initial Tolerance at 25°C		+/- 10		%	
Drift		0.03		%/°C	
EXCITATION CURRENT SOURCES					
Output Current		-200		μA	Available from each Current Source
Initial Tolerance at 25°C		+/-10		%	
Drift		200		ppm/°C	Matching between both Current Sources
Initial Current Matching at 25°C		+/-1		%	
Drift Matching		20		ppm/°C	AV _{DD} =5V +/- 5%
Line Regulation (AV _{DD})		1		μA/V	
Load Regulation			0.1	V	
Output Compliance	A _{GND}		AV _{DD} -0.6	V	

Preliminary Technical Data

ADuC845

PARAMETER	MIN	TYP	MAX	UNITS	CONDITION
POWER SUPPLY MONITOR (PSM)					
AV _{DD} Trip Point Selection Range	2.63		4.63	V	Four Trip Points selectable in this range
AV _{DD} Trip Point Accuracy			+/- 3.0	%	T _{MAX} = 85°C
AV _{DD} Trip Point Accuracy			+/- 3.0	%	T _{MAX} = 125°C
DV _{DD} Trip Point Selection Range	2.63		4.63	V	Four Trip Points selectable in this range
DV _{DD} Trip Point Accuracy			+/- 3.0	%	T _{MAX} = 85°C
DV _{DD} Trip Point Accuracy			+/- 3.0	%	T _{MAX} = 125°C
CRYSTAL OSCILLATOR (XTAL1 AND XTAL2)					
Logic Inputs, XTAL1 Only ²					
V _{INL} , Input Low Voltage			0.8	V	DV _{DD} = 5V
			0.4	V	DV _{DD} = 3V
V _{INH} , Input Low Voltage	3.5			V	DV _{DD} = 5V
	2.5			V	DV _{DD} = 3V
XTAL1 Input Capacitance		18		pF	
XTAL2 Output Capacitance		18		pF	
LOGIC INPUTS					
All Inputs except SCLOCK, RESET and XTAL1 ²					
V _{INL} , Input Low Voltage			0.8	V	DV _{DD} = 5V
			0.4	V	DV _{DD} = 3V
V _{INH} , Input Low Voltage	2.0			V	
SCLOCK and RESET Only (Schmidt Triggered Inputs) ²					
V _{T+}	1.3		3.0	V	DV _{DD} = 5V
	0.95		2.5	V	DV _{DD} = 3V
V _{T-}	0.8		1.4	V	DV _{DD} = 5V
	0.4		1.1	V	DV _{DD} = 3V
V _{T+} - V _{T-}	0.3		0.85	V	DV _{DD} = 5V or 3V
Input Currents					
Port 0, P1.0→P1.7, \overline{EA}	2.0			V	V _{IN} = 0V or V _{DD}
SCLOCK, MOSI, MISO \overline{SS} ¹³			+/- 10	μA	V _{IN} = 0V, DV _{DD} =5V, Internal Pullup
			-10	μA	V _{IN} = DV _{DD} , DV _{DD} =5V
RESET			+/-10	μA	V _{IN} = 0V, DV _{DD} =5V
	35		105	μA	V _{IN} = DV _{DD} , DV _{DD} =5V, Internal Pull-Down
Port 2, Port 3			+/-10	μA	V _{IN} = DV _{DD} , DV _{DD} =5V
	-180		-660	μA	V _{IN} = 2V, DV _{DD} =5V
	-20		-75	μA	V _{IN} = 0.45V, DV _{DD} =5V
Input Capacitance		10		pF	All Digital Inputs
LOGIC OUTPUTS					
All Digital Outputs except XTAL2 ²					
V _{OH} , Output High Voltage	2.4			V	DV _{DD} = 5V, I _{SOURCE} = 80 μA
	2.4			V	DV _{DD} = 3V, I _{SOURCE} = 20 μA
V _{OL} , Output Low Voltage ¹⁴			0.8	V	I _{SINK} = 8mA, SCLOCK, MOSI/SDATA
			0.8	V	I _{SINK} = 10mA, P1.0, P1.1
			0.8	V	I _{SINK} = 1.6mA, All Other Outputs
Floating State Leakage Current			+/-10	μA	
Floating State Output Capacitance		10		pF	

Preliminary Technical Data

ADuC845

PARAMETER	MIN	TYP	MAX	UNITS	CONDITION	
START UP TIME						
At Power On		300		ms	Controlled via WDCON SFR PLLCON.7 = 0 PLLCON.7 = 1	
After External RESET in Normal Mode		3		ms		
After WDT RESET in Normal Mode		3		ms		
From Idle Mode		10		us		
From Power-Down Mode						
Oscillator Running						
Wakeup with INT0 Interrupt		20		us		
Wakeup with SPI Interrupt		20		us		
Wakeup with TIC Interrupt		20		us		
Wakeup with External RESET		3		us		
Oscillator Powered Down						
Wakeup with INT0 Interrupt		20		us		
Wakeup with SPI Interrupt		20		us		
Wakeup with External RESET		5		ms		
FLAH/EE MEMORY RELIABILITY CHARACTERISTICS						
Endurance ¹⁶		100,000	700,000		Cycles	
Data Retention ¹⁷		100				
POWER REQUIREMENTS						
Power Supply Voltages						
AV _{DD} 3V Nominal	2.85		3.6	V		
AV _{DD} 5V Nominal	4.75		5.25	V		
DV _{DD} 3V Nominal	2.85		3.6	V		
DV _{DD} 5V Nominal	4.75		5.25	V		
5V POWER CONSUMPTION						
Normal Mode ^{18, 19}						
DV _{DD} Current			4	mA	4.75V < DVDD < 5.25V, AVDD = 5.25V core clock = 1.57MHz core clock = 12.58MHz	
		13	16	mA		
AV _{DD} Current			180	μA		
Power-Down Mode ^{18, 19}						
DV _{DD} Current			53	μA	T _{MAX} = 85°C; Osc ON; TIC ON T _{MAX} = 125°C; Osc ON; TIC ON T _{MAX} = 85°C; Osc OFF T _{MAX} = 125°C; Osc OFF T _{MAX} = 85°C; Osc ON or OFF T _{MAX} = 125°C; Osc ON or OFF	
			100	μA		
DV _{DD} Current			30	μA		
			80	μA		
AV _{DD} Current			1	μA		
			3	μA		
Typical Additional Peripheral Currents (AI _{DD} and DI _{DD})						
Primary ADC		1		mA		
Auxiliary ADC		0.5		mA		
Power Supply Monitor		50		μA		
DAC		150		μA		
Dual Excitation Current Sources		400		μA		
3V POWER CONSUMPTION						
Normal Mode ^{18, 19}						
DV _{DD} Current			2.3	mA	4.75V < DVDD < 5.25V, AVDD = 5.25V core clock = 1.57MHz core clock = 12.58MHz	
		8	10	mA		
AV _{DD} Current			180	μA		
Power-Down Mode ^{18, 19}						
DV _{DD} Current			20	μA	T _{MAX} = 85°C; Osc ON; TIC ON T _{MAX} = 125°C; Osc ON; TIC ON Osc OFF T _{MAX} = 125°C; Osc OFF T _{MAX} = 85°C; Osc ON or OFF T _{MAX} = 125°C; Osc ON or OFF	
			40	μA		
DV _{DD} Current		10		μA		
			80	μA		
AV _{DD} Current			1	μA		
			3	μA		

NOTES

- 1 Temperature Range for ADuC845BS (MQFP package) is -40°C to $+125^{\circ}\text{C}$.
Temperature Range for ADuC845BCP (CSP package) is -40°C to $+85^{\circ}\text{C}$.
- 2 These numbers are not production tested but are guaranteed by design and/or characterization data on production release.
- 3 System Zero-Scale Calibration can remove this error.
- 4 The primary ADC is factory calibrated at 25°C with $\text{AVDD} = \text{DVDD} = 5\text{ V}$ yielding this full-scale error of $10\ \mu\text{V}$. If user power supply or temperature conditions are significantly different from these, an Internal Full-Scale Calibration will restore this error to $10\ \mu\text{V}$. A system zero-scale and full-scale calibration will remove this error altogether.
- 5 Gain Error Drift is a span drift. To calculate Full-Scale Error Drift, add the Offset Error Drift to the Gain Error Drift times the full-scale input.
- 6 The auxiliary ADC is factory calibrated at 25°C with $\text{AVDD} = \text{DVDD} = 5\text{ V}$ yielding this full-scale error of -2.5 LSB . A system zero-scale and full-scale calibration will remove this error altogether.
- 7 DAC linearity and ac specifications are calculated using: reduced code range of 48 to 4095, 0 to VREF, reduced code range of 100 to 3950, 0 to VDD.
- 8 Gain Error is a measure of the span error of the DAC.
- 9 In general terms, the bipolar input voltage range to the primary ADC is given by $\text{RangeADC} = \pm(\text{VREF} \cdot 2^{\text{RN}})/125$, where:
VREF = REFIN(+) to REFIN(-) voltage and VREF = 1.25 V when internal ADC VREF is selected.
RN = decimal equivalent of RN2, RN1, RN0
e.g., VREF = 2.5 V and RN2, RN1, RN0 = 1, 1, 0 the $\text{RangeADC} = \pm 1.28\text{ V}$, In unipolar mode, the effective range is 0 V to 1.28 V in our example.
- 10 1.25 V is used as the reference voltage to the ADC when internal VREF is selected via XREF0 and XREF1 bits in ADC0CON and ADC1CON, respectively.
- 11 In bipolar mode, the Auxiliary ADC can only be driven to a minimum of $\text{AGND} - 30\text{ mV}$ as indicated by the Auxiliary ADC absolute AIN voltage limits. The bipolar range is still $-\text{VREF}$ to $+\text{VREF}$; however, the negative voltage is limited to -30 mV .
- 12 The ADuC845BCP (CSP Package) has been qualified and tested with the base of the CSP Package floating.
- 13 Pins configured in SPI Mode, pins configured as digital inputs during this test.
- 14 Pins configured in I^2C Mode only.
- 15 Flash/EE Memory Reliability Characteristics apply to both the Flash/EE program memory and Flash/EE data memory.
- 16 Endurance is qualified to 100 Kcycles as per JEDEC Std. 22 method A117 and measured at -40°C , $+25^{\circ}\text{C}$, $+85^{\circ}\text{C}$, and $+125^{\circ}\text{C}$. Typical endurance at 25°C is 700 Kcycles.
- 17 Retention lifetime equivalent at junction temperature (TJ) = 55°C as per JEDEC Std. 22, Method A117. Retention lifetime based on an activation energy of 0.6eV will derate with junction temperature.
- 18 Power Supply current consumption is measured in Normal, Idle, and Power-Down Modes under the following conditions:
Normal Mode: Reset = 0.4 V, Digital I/O pins = open circuit, Core Clk changed via CD bits in PLLCON, Core Executing internal software loop.
Idle Mode: Reset = 0.4 V, Digital I/O pins = open circuit, Core Clk changed via CD bits in PLLCON, PCON.0 = 1, Core Execution suspended in idle mode.
Power-Down Mode: Reset = 0.4 V, All P0 pins and P1.2–P1.7 Pins = 0.4 V, All other digital I/O pins are open circuit, Core Clk changed via CD bits in PLLCON, PCON.1 = 1, Core Execution suspended in power-down mode, OSC turned ON or OFF via OSC_PD bit (PLLCON.7) in PLLCON SFR.
- 19 DVDD power supply current will increase typically by 3 mA (3 V operation) and 10 mA (5 V operation) during a Flash/EE memory program or erase cycle.

Specifications subject to change without notice

Preliminary Technical Data

ADuC845

ABSOLUTE MAXIMUM RATINGS¹

(TA = 25°C unless otherwise noted)

AVDD to AGND	-0.3 V to +7 V
AVDD to DGND	-0.3 V to +7 V
DVDD to AGND	-0.3 V to +7 V
DVDD to DGND	-0.3 V to +7 V
AGND to DGND ²	-0.3 V to +0.3 V
AVDD to DVDD	-2 V to +5 V
Analog Input Voltage to AGND ³	-0.3 V to AVDD +0.3 V
Reference Input Voltage to AGND	-0.3 V to AVDD +0.3 V
AIN/REFIN Current (Indefinite)	30 mA
Digital Input Voltage to DGND	-0.3 V to DVDD +0.3 V
Digital Output Voltage to DGND	-0.3 V to DVDD +0.3 V
Operating Temperature Range	-40°C to +125°C
Storage Temperature Range	-65°C to +150°C
Junction Temperature	150°C
qJA Thermal Impedance	90°C/W
Lead Temperature, Soldering	
Vapor Phase (60 sec)	215°C
Infrared (15 sec)	220°C

¹Stresses above those listed under Absolute Maximum Ratings may cause permanent damage to the device. This is a stress rating only; functional operation of the device at these or any other conditions above those listed in the operational sections of this specification is not implied. Exposure to absolute maximum rating conditions for extended periods may affect device reliability.

²AGND and DGND are shorted internally on the ADuC845.

³Applies to P1.0 to P1.7 pins operating in analog or digital input modes.

PIN CONFIGURATION

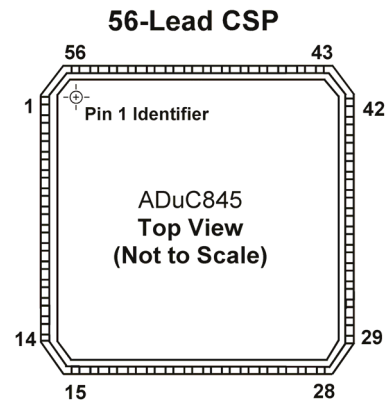
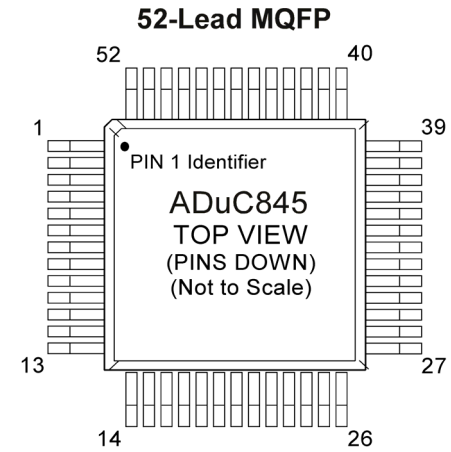

ORDERING GUIDE

MODEL	Temperature Range	Package Description	Package Option
ADuC845BS62-5	-40 → +125°C	52-Lead Plastic Quad Flatpack, 62kB, 5v	S-52
ADuC845BS62-3	-40 → +125°C	52-Lead Plastic Quad Flatpack, 62kB, 3v	S-52
ADuC845BCP62-5	-40 → +85°C	56-Lead Chip Scale Package, 62kB, 5v	CP-56
ADuC845BCP62-3	-40 → +85°C	56-Lead Chip Scale Package, 62kB, 3v	CP-56
ADuC845BCP32-5	-40 → +85°C	56-Lead Chip Scale Package, 32kB, 5v	CP-56
ADuC845BCP32-3	-40 → +85°C	56-Lead Chip Scale Package, 32kB, 3v	CP-56
ADuC845BCP8-5	-40 → +85°C	56-Lead Chip Scale Package, 8kB, 5v	CP-56
ADuC845BCP8-3	-40 → +85°C	56-Lead Chip Scale Package, 8kB, 3v	CP-56
EVAL-ADuC845QS		QuickStart™ Development System	
EVAL-ADuC845QSP		QuickStart PLUS Development System	

CAUTION

ESD (electrostatic discharge) sensitive device. Electrostatic charges as high as 4000 V readily accumulate on the human body and test equipment and can discharge without detection. Although the ADuC845 features proprietary ESD protection circuitry, permanent damage may occur on devices subjected to high-energy electrostatic discharges. Therefore, proper ESD precautions are recommended to avoid performance degradation or loss of functionality.



PIN FUNCTION DESCRIPTIONS

Pin No: 52-MQFP	Pin No: 56-CSP	Pin Mnemonic	Type*	Description
1	56	P1.0/AIN0	I	By power on default P1.0/AIN0 is configured as the AIN0 Analog Input. AIN0 can be used as a pseudo differential input when used with AINCOM or as the positive input of a fully differential pair when used with AIN2. P1.0 has no digital output driver. It can function as a digital input for which '0' must be written to the port bit. As a digital input, this pin must be driven high or low externally.
2	1	P1.1/AIN1	I	By power on default P1.1/AIN1 is configured as the AIN1 Analog Input. AIN1 can be used as a pseudo differential input when used with AINCOM or as the negative input of a fully differential pair when used with AIN0. P1.1 has no digital output driver. It can function as a digital input for which '0' must be written to the port bit. As a digital input, this pin must be driven high or low externally.
3	2	P1.2/AIN2/REFIN2+	I	By power on default P1.2/AIN2 is configured as the AIN2 Analog Input. AIN2 can be used as a pseudo differential input when used with AINCOM or as the positive input of a fully differential pair when used with AIN3. P1.2 has no digital output driver. It can function as a digital input for which '0' must be written to the port bit. As a digital input, this pin must be driven high or low externally. This pin also functions as a second external differential reference input, positive terminal.
4	3	P1.3/AIN3/REFIN2-	I	By power on default P1.3/AIN3 is configured as the AIN3 Analog Input. AIN3 can be used as a pseudo differential input when used with AINCOM or as the negative input of a fully differential pair when used with AIN2. P1.3 has no digital output driver. It can function as a digital input for which '0' must be written to the port bit. As a digital input, this pin must be driven high or low externally. This pin also functions as a second external differential reference input, negative terminal.
5	4	AVDD	S	Analog Supply Voltage
6	5	AGND	S	Analog Ground.
---	6	AGND	S	A second Analog ground is provided with the CSP version only*
7	7	REFIN-	I	External Differential Reference Input, negative terminal
8	8	REFIN+	I	External Differential Reference Input, positive terminal
9	9	P1.4/AIN4	I	By power on default P1.4/AIN4 is configured as the AIN4 Analog Input. AIN4 can be used as a pseudo differential input when used with AINCOM or as the positive input of a fully differential pair when used with AIN5. P1.0 has no digital output driver. It can function as a digital input for which '0' must be written to the port bit. As a digital input, this pin must be driven high or low externally.
10	10	P1.5/AIN5	I	By power on default P1.5/AIN5 is configured as the AIN5 Analog Input. AIN5 can be used as a pseudo differential input when used with AINCOM or as the negative input of a fully differential pair when used with AIN4. P1.1 has no digital output driver. It can function as a digital input for which '0' must be written to the port bit. As a digital input, this pin must be driven high or low externally.
11	11	P1.6/AIN6/IEXC1	I/O	By power on default P1.6/AIN6 is configured as the AIN6 Analog Input. AIN6 can be used as a pseudo differential input when used with AINCOM or as the positive input of a fully differential pair when used with AIN7. One or Both current sources can also be configured at this pin. P1.0 has no digital output driver. It can function as a digital input for which '0' must be written to the port bit. As a digital input, this pin must be driven high or low externally.

*Note: This pin is provided on the CSP version only.

Preliminary Technical Data

ADuC845

Pin No: 52-MQFP	Pin No: 56-CSP	Pin Mnemonic	Type*	Description
12	12	P1.7/AIN7/IEXC2	I/O	By power on default P1.7/AIN7 is configured as the AIN7 Analog Input. AIN7 can be used as a pseudo differential input when used with AINCOM or as the negative input of a fully differential pair when used with AIN6. One or Both current sources can also be configured at this pin P1.1 has no digital output driver. It can function as a digital input for which '0' must be written to the port bit. As a digital input, this pin must be driven high or low externally.
13	13	AINCOM/DAC	I/O	All analog inputs can be referred to this pin provided a relevant pseudo differential input mode is selected. This pin also functions as an alternative pin out for the DAC.
14	14	DAC	O	The voltage output from the DAC, if enabled, will appear at this pin.
----	15	AIN8	I	AIN8 can be used as a pseudo differential analog input when used with AINCOM or as the positive input of a fully differential pair when used with AIN9*.
----	16	AIN9	I	AIN9 can be used as a pseudo differential analog input when used with AINCOM or as the negative input of a fully differential pair when used with AIN8*.
15	17	RESET	I	Reset Input. A high level on this pin for 16 core clock cycles while the oscillator is running resets the device. There is an internal weak pull-down and a Schmitt trigger input stage on this pin.
16-19 22-25	18-21 24-27	P3.0 → P3.7	I/O	P3.0–P3.7 are bi-directional port pins with internal pull-up resistors. Port 3 pins that have 1s written to them are pulled high by the internal pull-up resistors, and in that state can be used as inputs. As inputs, Port 3 pins being pulled externally low will source current because of the internal pull-up resistors. When driving a 0-to-1 output transition, a strong pull-up is active for two core clock periods of the instruction cycle. Port 3 pins also have various secondary functions described below.
16	18	P3.0/RXD		Receiver Data for UART serial Port
17	19	P3.1/TXD		Transmitter Data for UART serial Port
18	20	P3.2/INT0		External Interrupt 0. This pin can also be used as a gate control input to Timer0.
19	21	P3.3/INT1		External Interrupt 1. This pin can also be used as a gate control input to Timer1.
22	24	P3.4/T0		Timer/Counter 0 External Input
23	25	P3.5/T1		Timer/Counter 1 External Input
24	26	P3.6//WR		External Data Memory Write Strobe. Latches the data byte from Port 0 into an external data memory.
25	27	P3.7//RD		External Data Memory Read Strobe. Enables the data from an external data memory to Port 0.
20, 34, 48	22, 36, 51	DVDD	S	Digital Supply Voltage
21, 35, 47	23, 37, 38, 50	DGND	S	Digital Ground.
26	28	SCLK (I2C)	I/O	Serial interface clock for the I2C interface. As an input this pin is a Schmitt triggered input and a weak internal pull-up is present on this pin unless it is outputting logic low. this pin can also be controlled in software as a digital output pin.
27	29	SDATA	I/O	Serial data pin for the I ² C interface. As an input this pin has a weak internal pull-up present unless it is outputting logic low.

*Note: This pin is provided on the CSP version only.

Pin No: 52-MQFP	Pin No: 56-CSP	Pin Mnemonic	Type*	Description
28 → 31 36 → 39	30 → 33 39 → 42	P2.0 → P2.7	I/O	Port 2 is a bidirectional port with internal pull-up resistors. Port 2 pins that have 1s written to them are pulled high by the internal pull-up resistors, and in that state can be used as inputs. As inputs, Port 2 pins being pulled externally low will source current because of the internal pull-up resistors. Port 2 emits the middle and high order address bytes during accesses to the 24-bit external data memory space. Port 2 pins also have various secondary functions described below.
28	30	P2.0/SCLOCK (SPI)		Serial interface clock for the SPI interface. As an input this pin is a Schmitt triggered input and a weak internal pull-up is present on this pin unless it is outputting logic low.
29	31	P2.1/MOSI		Serial master output/slave input data for the SPI interface. A strong internal pull-up is present on this pin when the SPI interface outputs a logic high. A strong internal pull-down is present on this pin when the SPI interface outputs a logic low.
30	32	P2.2/MISO		Master Input/Slave Output for the SPI Interface. There is a weak pull-up on this input pin.
31	33	P2.3/ \overline{SS} /T2		Slave select input for the SPI Interface is present at this pin. A weak pull-up is present on this pin. On both package options this pin can also be used to provide a clock input to Timer 2. When Enabled, counter 2 is incremented in response to a negative transition on the T2 input pin.
36	39	P2.4/T2EX		This pin can be used to provide a control input to Timer 2. When Enabled, a negative transition on the T2EX input pin will cause a Timer 2 capture or reload event.
37	40	P2.5/PWM0		If the PWM is enabled then the PWM0 output will appear at this pin.
38	41	P2.6/PWM1		If the PWM is enabled then the PWM1 output will appear at this pin.
39	42	P2.7/PWMCLK		If the PWM is enabled then an external PWM clock can be provided at this pin.
32	34	XTAL1	I	Input to the crystal oscillator inverter.
33	35	XTAL2	O	Output from the crystal oscillator inverter. (see “Hardware Design Considerations” for description)
40	43	\overline{EA}		External Access Enable, Logic Input. When held high, this input enables the device to fetch code from internal program memory locations 0000h to F7FFh. No external program memory access is available on the ADuC845. To determine the mode of code execution, the \overline{EA} pin is sampled at the end of an external RESET assertion or as part of a device power cycle. \overline{EA} may also be used as an external emulation I/O pin and therefore the voltage level at this pin must not be changed during normal mode operation as it may cause an emulation interrupt that will halt code execution.
41	44	PSEN		Program Store Enable, Logic Output. It is active every six oscillator periods except during external data memory accesses. This pin remains high during internal program execution. PSEN can also be used to enable serial download mode when pulled low through a resistor at the end of an external RESET assertion or as part of a device power cycle.
42	45	ALE		Address Latch Enable, Logic Output. This output is used to latch the low byte (and page byte for 24-bit data address space accesses) of the address to external memory during external data memory access cycles. It is activated every six oscillator periods except during an external data memory access. It can be disabled by setting the PCON.4 bit in the PCON SFR.

Pin No: 52-MQFP	Pin No: 56-CSP	Pin Mnemonic	Type*	Description
43 → 46 49 → 52	46 → 49 52 → 55	P0.0 → P0.7	I/O	P0.0–P0.7, these pins are part of Port0 which is an 8-bit open-drain bidirectional I/O port. Port 0 pins that have 1s written to them float and in that state can be used as high impedance inputs. An external pull-up resistor will be required on P0 outputs to force a valid logic high level externally. Port 0 is also the multiplexed low-order address and data bus during accesses to external data memory. In this application it uses strong internal pull-ups when emitting 1s.

*I = Input, O = Output, S = Supply.

DETAILED BLOCK DIAGRAM WITH PIN NUMBERS

Pin numbers refer to the 52pin MQFP package.

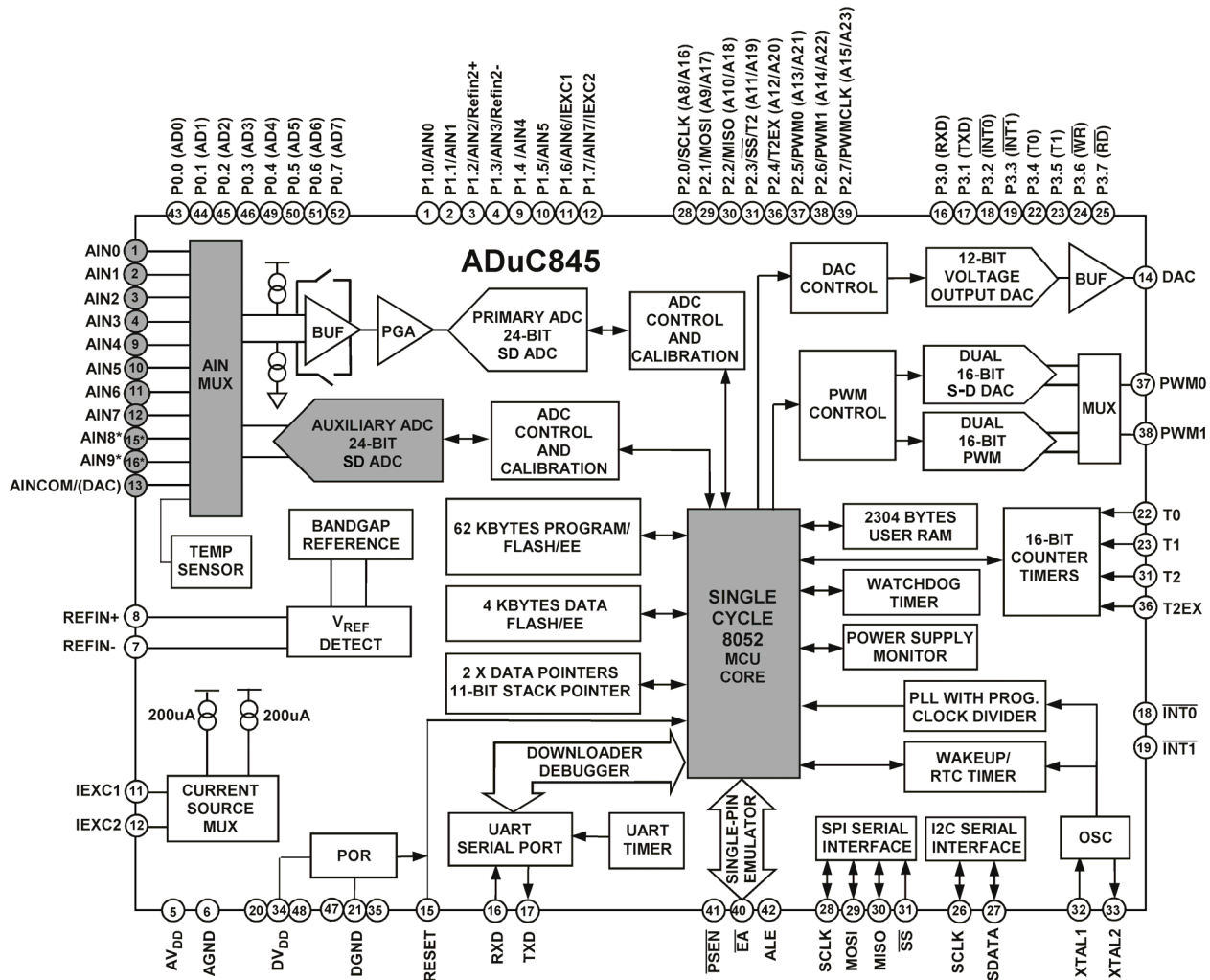

* CSP PACKAGE ONLY. The pin numbers refer to the CSP package only.

Shaded areas are upgrades from the ADuC834, and include a single cycle core, up to 10 ADC input channels (8 on the MQFP package), and the Auxiliary ADC is now 24-bit.

Figure 1: Detailed Block Diagram of the ADuC845

COMPLETE SFR MAP

Figure 6 below shows a full SFR memory map and the SFR contents after RESET. NOT USED indicates unoccupied SFR locations. Unoccupied locations in the SFR address space are not implemented; i.e., no register exists at this location. If an unoccupied location is read, an unspecified value is returned. SFR locations that are reserved for future use are shaded (RESERVED) and should not be accessed by user software.

ISPI FFH 0	WCOL FEH 0	SPE FDH 0	SPIM FCH 0	CPOL FBH 0	CPHA FAH 1	SPR1 F9H 0	SPR0 F8H 0	BITS	SPICON F8H 04H	RESERVED	RESERVED	DACL FBH 00H	DACH FCH 00H	DACCON FDH 00H	RESERVED	RESERVED
F7H 0	F6H 0	F5H 0	F4H 0	F3H 0	F2H 0	F1H 0	F0H 0	BITS	B F0H 00H	RESERVED	I2CADD1 F2H 7FH	NOT USED	RESERVED	RESERVED	RESERVED	SPIDAT F7H 00H
MDO EFH 0	MDE EEH 0	MC0 EDH 0	MDI ECH 0	I2CM EBH 0	I2CRS EAH 0	I2CTX E9H 0	I2CI E8H 0	BITS	I2CCON E8H 00H	GN0L ² E9H 55H	GN0M ² EAH 55H	GN0H ² EBH 53H	GN1L ² ECH 9AH	GN1H ² EDH 59H	RESERVED	RESERVED
E7H 0	E6H 0	E5H 0	E4H 0	E3H 0	E2H 0	E1H 0	E0H 0	BITS	ACC E0H 00H	OF0L E1H 00H	OF0M E2H 00H	OF0H E3H 80H	OF1L E4H 00H	OF1H E5H 80H	ADC0CON2 E6H 00H	RESERVED
RDY0 DFH 0	RDY1 DEH 0	CAL DDH 0	NOXREF DCH 0	ERR0 DBH 0	ERR1 DAH 0	D9H 0	D8H 0	BITS	ADCSTAT D8H 00H	ADC0L D9H 00H	ADC0M DAH 00H	ADC0H DBH 00H	ADC1M DCH 00H	ADC1H DDH 00H	ADC1L DEH 00H	PSMCON DFH DEH
CY D7H 0	AC D6H 0	F0 D5H 0	RSI D4H 0	RS0 D3H 0	OV D2H 0	FI D1H 0	P D0H 0	BITS	PSW D0H 00H	ADCMODE D1H 10H	ADC0CON1 D2H 07H	ADC1CON D3H 00H	SF D4H 45H	ICON D5H 00H	RESERVED	PLLCON D7H 03H
TF2 CFH 0	EXF2 CEH 0	RCLK CDH 0	TCLK CCH 0	EXEN2 CBH 0	TR2 CAH 0	CNT2 C9H 0	CAP2 C8H 0	BITS	T2CON C8H 00H	RESERVED	RCAP2L CAH 00H	RCAP2H CBH 00H	TL2 CCH 00H	TH2 CDH 00H	RESERVED	RESERVED
PRE3 C7H 0	PRE2 C6H 0	PRE1 C5H 0	PRE0 C4H 1	WDIR C3H 0	WDS C2H 0	WDE C1H 0	WDWR C0H 0	BITS	WDCON C0H 10H	RESERVED	CHIPID C2H 22H	RESERVED	RESERVED	RESERVED	EADRL C6H 00H	EADRH C7H 00H
BFH 0	PADC BEH 0	PT2 BDH 0	PS BCH 0	PT1 BBH 0	PX1 BAH 0	PT0 B9H 0	PX0 B8H 0	BITS	IP B8H 00H	ECON B9H 00H	RESERVED	RESERVED	EDATA1 BCH 00H	EDATA2 BDH 00H	EDATA3 BEH 00H	EDATA4 BFH 00H
RD B7H 1	WR B6H 1	T1 B5H 1	T0 B4H 1	INT1 B3H 1	INT0 B2H 1	TXD B1H 1	RXD B0H 1	BITS	P3 B0H FFH	PWM0L B1H 00H	PWM0H B2H 00H	PWM1L B3H 00H	PWM1H B4H 00H	RESERVED	RESERVED	SPH B7H 00H
EA AFH 0	EADC AEH 0	ET2 ADH 0	ES ACH 0	ET1 ABH 0	EX1 AAH 0	ET0 A9H 0	EX0 A8H 0	BITS	IE A8H 00H	IEIP2 A9H A0H	RESERVED	RESERVED	RESERVED	RESERVED	PWMCON AEH 00H	CFG845 AFH 00H
A7H 1	A6H 1	A5H 1	A4H 1	A3H 1	A2H 1	A1H 1	A0H 1	BITS	P2 A0H FFH	TIMECON A1H 00H	HTHSEC ¹ A2H 00H	SEC ¹ A3H 00H	MIN ¹ A4H 00H	HOURL ¹ A5H 00H	INTVAL A6H 00H	DPCON A7H 00H
SM0 9FH 0	SM1 9EH 0	SM2 9DH 0	REN 9CH 0	TB8 9BH 0	RB8 9AH 0	T1 99H 0	R1 98H 0	BITS	SCON 98H 00H	SBUF 99H 00H	I2CDAT 9AH 00H	I2CADD 9BH 55H	RESERVED	T3FD 9DH 00H	T3CON 9EH 00H	RESERVED
97H 1	96H 1	95H 1	94H 1	93H 1	92H 1	91H 1	90H 1	BITS	P1 90H FFH	RESERVED	RESERVED	RESERVED	RESERVED	RESERVED	RESERVED	RESERVED
TF1 8FH 0	TR1 8EH 0	TF0 8DH 0	TR0 8CH 0	IE1 8BH 0	IT1 8AH 0	IE0 89H 0	IT0 88H 0	BITS	TCON 88H 00H	TMOD 89H 00H	TL0 8AH 00H	TL1 8BH 00H	TH0 8CH 00H	TH1 8DH 00H	RESERVED	RESERVED
87H 1	86H 1	85H 1	84H 1	83H 1	82H 1	81H 1	80H 1	BITS	P0 80H FFH	SP 81H 07H	DPL 82H 00H	DPH 83H 00H	DPP 84H 00H	RESERVED	RESERVED	PCON 87H 00H

¹ THESE SFRs MAINTAIN THEIR PRE-RESET VALUES AFTER A RESET IF TIMECON.0=1.

² CALIBRATION COEFFICIENTS ARE PRECONFIGURED AT POWER-UP TO FACTORY CALIBRATED VALUES.

SFR MAP KEY:

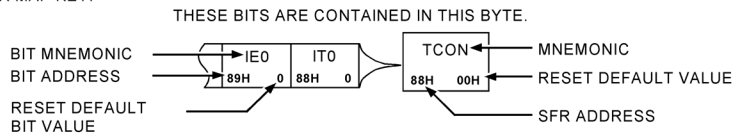

SFR NOTE:

SFRs WHOSE ADDRESSES END IN 0H OR 8H ARE BIT-ADDRESSABLE.

Figure 6: Complete SFR Map

INTRODUCTION

The ADuC845 is a 12.58MIPs 8052 core upgrade to the ADuC834. It includes additional analog inputs for applications requiring more ADC channels. It has all the same features as the ADuC834 but the standard 12-cycle 8052 core has been replaced with a 12.58MIPs single cycle core.

Since the ADuC845 and ADuC834 share the same feature set only the differences between the two chips are documented here. For full documentation on the ADuC834 please consult the datasheet available at <http://www.analog.com/microconverter>

GENERAL DESCRIPTION

The ADuC845 is a complete smart transducer front end, integrating two high resolution sigma-delta ADCs with flexible, 10/8-channel input multiplexing, a fast 8-bit MCU, and program/data Flash/EE memory on a single chip.

The two independent ADCs (primary and auxiliary) include flexible input multiplexing, a temperature sensor and a PGA (allowing direct measurement of low level signals). The ADCs with on-chip digital filtering and programmable output data rates are intended for the measurement of wide dynamic range, low frequency signals, such as those in weigh scale, strain-gage, pressure transducer, or temperature measurement applications.

The device operates from a 32 kHz crystal with an on-chip PLL generating a high frequency clock of 12.58 MHz. This clock is routed through a programmable clock divider from which the MCU core clock operating frequency is generated. The microcontroller core is an optimized single cycle 8052 offering up to 12.58MIPs performance while maintaining the 8051 instruction set compatibility.

62 Kbytes of nonvolatile Flash/EE program memory, 4 Kbytes of nonvolatile Flash/EE data memory, and 2304 bytes of data RAM are provided on-chip. The program memory can be configured as data memory to give up to 60 Kbytes of NV data memory in data logging applications.

On-chip factory firmware supports in-circuit serial download and debug modes (via UART), as well as single-pin emulation mode via the EA pin. The ADuC845 is supported by a QuickStart™ development system featuring low cost software and hardware development tools

8052 Instruction Set

The following pages document the number of clock cycles required for each instruction. Most instructions are executed in one or two clock cycles resulting in 12.6MIPs peak performance when operating at PLLCON = 00H.

Timer Operation

Timers on a standard 8052 increment by one with each machine cycle. On the ADuC842 one machine cycle is equal to one clock cycle hence the timers will increment at the same rate as the core clock.

ALE

The output on the ALE pin on the ADuC834 was a clock at 1/6th of the core operating frequency. On the ADuC845 the ALE pin operates as follows....

For a single machine cycle instruction: ALE is high for the first half of the machine cycle and low for the second half. The ALE output is at the core operating frequency. For a two or more machine cycle instruction: ALE is high for the first half of the first machine cycle and then low for the rest of the machine cycles.

External Memory Access

There is no support for external program memory access on the ADuC845. When accessing external RAM the EWAIT register may need to be programmed in order to give extra machine cycles to MOVX commands. This is to account for differing external RAM access speeds.

Preliminary Technical Data

ADuC845

INSTRUCTION TABLE

TABLE IV: Optimized Single Cycle 8051 Instruction Set

Mnemonic	Description	Bytes	Cycles
Arithmetic			
ADD A,Rn	Add register to A	1	1
ADD A,@Ri	Add indirect memory to A	1	2
ADD A,dir	Add direct byte to A	2	2
ADD A,#data	Add immediate to A	2	2
ADDC A,Rn	Add register to A with carry	1	1
ADDC A,@Ri	Add indirect memory to A with carry	1	2
ADDC A,dir	Add direct byte to A with carry	2	2
ADD A,#data	Add immediate to A with carry	2	2
SUBB A,Rn	Subtract register from A with borrow	1	1
SUBB A,@Ri	Subtract indirect memory from A with borrow	1	2
SUBB A,dir	Subtract direct from A with borrow	2	2
SUBB A,#data	Subtract immediate from A with borrow	2	2
INC A	Increment A	1	1
INC Rn	Increment register	1	1
INC @Ri	Increment indirect memory	1	2
INC dir	Increment direct byte	2	2
INC DPTR	Increment data pointer	1	3
DEC A	Decrement A	1	1
DEC Rn	Decrement Register	1	1
DEC @Ri	Decrement indirect memory	1	2
DEC dir	Decrement direct byte	2	2
MUL AB	Multiply A by B	1	9
DIV AB	Divide A by B	1	9
DA A	Decimal Adjust A	1	2
Logic			
ANL A,Rn	AND register to A	1	1
ANL A,@Ri	AND indirect memory to A	1	2
ANL A,dir	AND direct byte to A	2	2
ANL A,#data	AND immediate to A	2	2
ANL dir,A	AND A to direct byte	2	2
ANL dir,#data	AND immediate data to direct byte	3	3
ORL A,Rn	OR register to A	1	1
ORL A,@Ri	OR indirect memory to A	1	2
ORL A,dir	OR direct byte to A	2	2
ORL A,#data	OR immediate to A	2	2
ORL dir,A	OR A to direct byte	2	2
ORL dir,#data	OR immediate data to direct byte	3	3
XRL A,Rn	Exclusive-OR register to A	1	1
XRL A,@Ri	Exclusive-OR indirect memory to A	2	2
XRL A,#data	Exclusive-OR immediate to A	2	2
XRL dir,A	Exclusive-OR A to direct byte	2	2
XRL A,dir	Exclusive-OR indirect memory to A	2	2
XRL dir,#data	Exclusive-OR immediate data to direct	3	3
CLR A	Clear A	1	1
CPL A	Complement A	1	1
SWAP A	Swap Nibbles of A	1	1
RL A	Rotate A left	1	1
RLC A	Rotate A left through carry	1	1
RR A	Rotate A right	1	1
RRC A	Rotate A right through carry	1	1
Data Transfer			
MOV A,Rn	Move register to A	1	1
MOV A,@Ri	Move indirect memory to A	1	2
MOV Rn,A	Move A to register	1	1
MOV @Ri,A	Move A to indirect memory	1	2
MOV A,dir	Move direct byte to A	2	2
MOV A,#data	Move immediate to A	2	2

Preliminary Technical Data

ADuC845

Mnemonic	Description	Bytes	Cycles
MOV Rn,#data	Move register to immediate	2	2
MOV dir,A	Move A to direct byte	2	2
MOV Rn, dir	Move register to direct byte	2	2
MOV dir, Rn	Move direct to register	2	2
MOV @Ri,#data	Move immediate to indirect memory	2	2
MOV dir,@Ri	Move indirect to direct memory	2	2
MOV @Ri,dir	Move direct to indirect memory	2	2
MOV dir,dir	Move direct byte to direct byte	3	3
MOV dir,#data	Move immediate to direct byte	3	3
MOV DPTR,#data	Move immediate to data pointer	3	3
MOVC A,@A+DPTR	Move code byte relative DPTR to A	1	4
MOVC A,@A+PC	Move code byte relative PC to A	1	4
MOVX A,@Ri	Move external (A8) data to A	1	4
MOVX A,@DPTR	Move external (A16) data to A	1	4
MOVX @Ri,A	Move A to external data (A8)	1	4
MOVX @DPTR,A	Move A to external data (A16)	1	4
PUSH dir	Push direct byte onto stack	2	2
POP dir	Pop direct byte from stack	2	2
XCH A,Rn	Exchange A and register	1	1
XCH A,@Ri	Exchange A and indirect memory	1	2
XCHD A,@Ri	Exchange A and indirect memory nibble	1	2
XCH A,dir	Exchange A and direct byte	2	2
Boolean			
CLR C	Clear carry	1	1
CLR bit	Clear direct bit	2	2
SETB C	Set Carry	1	1
SETB bit	Set direct bit	2	2
CPL C	Complement carry	1	1
CPL bit	Complement direct bit	2	2
ANL C,bit	AND direct bit and carry	2	2
ANL C,/bit	AND direct bit inverse to carry	2	2
ORL C,bit	OR direct bit and carry	2	2
ORL C,/bit	OR direct bit inverse to carry	2	2
MOV C,bit	Move direct bit to carry	2	2
MOV bit,C	Move carry to direct bit	2	2
Branching			
JMP @A+DPTR	Jump indirect relative to DPTR	1	3
RET	Return from subroutine	1	4
RETI	Return from interrupt	1	4
ACALL addr11	Absolute jump to subroutine	2	3
AJMP addr11	Absolute jump unconditional	2	3
SJMP rel	Short jump (relative address)	2	3
JC rel	Jump on carry = 1	2	3
JNC rel	Jump on carry = 0	2	3
JZ rel	Jump on accumulator = 0	2	3
JNZ rel	Jump on accumulator != 0	2	3
DJNZ Rn,rel	Decrement register, jnz relative	2	3
LJMP	Long jump unconditional	3	4
LCALL addr16	Long jump to subroutine	3	4
JB bit,rel	Jump on direct bit = 1	3	4
JNB bit,rel	Jump on direct bit = 0	3	4
JBC bit,rel	Jump on direct bit = 1 and clear	3	4
CJNE A,dir,rel	Compare A, direct JNE relative	3	4
CJNE A,#data,rel	Compare A, immediate JNE relative	3	4
CJNE Rn,#data,rel	Compare register, immediate JNE relative	3	4
CJNE @Ri,#data,rel	Compare indirect, immediate JNE relative	3	4
DJNZ dir,rel	Decrement direct byte, JNZ relative	3	4
Miscellaneous			
NOP	No operation	1	1

1. One cycle is one clock.

2. MOVX instructions are four cycles when they have 0 wait state. Cycles of MOVX instructions are 4 + n cycles when they have n wait states.

3. LCALL instruction are three cycles when the LCALL instruction comes from an interrupt.

Preliminary Technical Data

ADuC845

MEMORY ORGANISATION

The ADuC845 contains 4 different memory blocks namely:

- 62k/30k/6k Bytes of On-Chip Flash/EE Program Memory
- 4kBytes of On-Chip Flash/EE Data Memory
- 256 Bytes of General Purpose RAM
- 2kBytes of Internal XRAM

(1) Flash/EE Program Memory

The ADuC845 provides up to 62kBytes of Flash/EE program memory to run user code.

When \overline{EA} is pulled high externally during a power cycle or a hardware reset the part defaults to code execution from its internal 62kBytes of Flash/EE program memory. The ADuC845 does not support the rollover from internal code space to external code space. No external code space is available on the ADuC845. Permanently embedded firmware allows code to be serially downloaded to the 62kBytes of internal code space via the UART serial port while the device is in-circuit. No external hardware is required.

56kBytes of the program memory can be reprogrammed during runtime hence the code space can be upgraded in the field using a user defined protocol or it can be used as a data memory. This will be discussed in more detail in the Flash/EE Memory section of the datasheet.

(2) Flash/EE Data Memory

4kBytes of Flash/EE Data Memory are available to the user and can be accessed indirectly via a group of registers mapped into the Special Function Register (SFR) area. Access to the Flash/EE Data memory is discussed in detail later as part of the Flash/EE memory section in this data sheet.

(3) General Purpose RAM

The general purpose RAM is divided into two separate memories, namely the upper and the lower 128 bytes of RAM. The lower 128 bytes of RAM can be accessed through direct or indirect addressing while the upper 128 bytes of RAM can only be accessed through indirect addressing as it shares the same address space as the SFR space which can only be accessed through direct addressing. The lower 128 bytes of internal data memory are mapped as shown in Figure 2. The lowest 32 bytes are grouped into four banks of eight registers addressed as R0 through R7. The next 16 bytes (128 bits), locations 20Hex through 2FHex above the register banks, form a block of directly addressable bit locations at bit addresses 00H through 7FH. The stack can be located anywhere in the internal memory address space, and the stack depth can be expanded up to 2048 bytes.

Reset initializes the stack pointer to location 07 hex. Any call or push pre-increments the SP before loading the stack. Hence loading the stack starts from locations 08 hex which is also the first register (R0) of register bank 1. Thus, if one is going to use more than one register bank, the stack pointer should be initialized to an area of RAM not used for data storage.

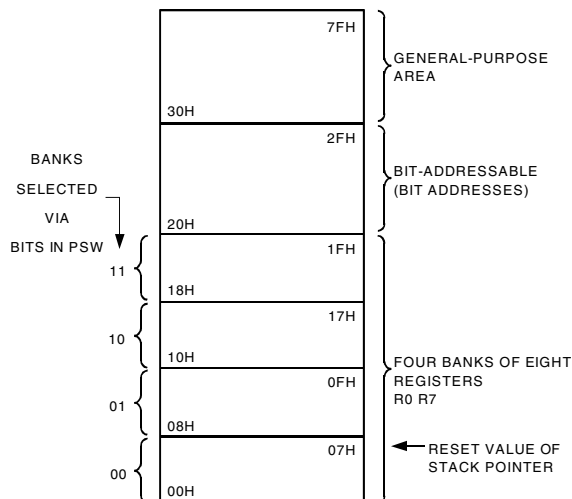

Figure 2. Lower 128 Bytes of Internal Data Memory

(4) Internal XRAM

The ADuC845 contains 2kBytes of on-chip extended data memory. This memory, although on-chip, is accessed via the MOVX instruction. The 2kBytes of internal XRAM are mapped into the bottom 2kBytes of the external address space if the CFG845.0 (see Table III) bit is set, otherwise access to the external data memory will occur just like a standard 8051.

Even with the CFG845.0 bit set access to the external XRAM will occur once the 24 bit DPTR is greater than 0007FFH.

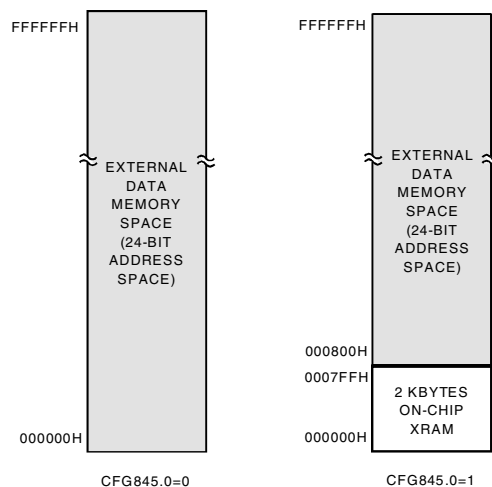

Figure 3: Internal and External XRAM

When accessing the internal XRAM, the P0, P2 port pins as well as the RD and WR strobes will not be output as per a standard 8051 MOVX instruction. This allows the user to use these port pins as standard I/O.

The upper 1792 bytes of the internal XRAM can be configured to be used as an extended 11-bit stack pointer.

By default the stack will operate exactly like an 8052 in that it will rollover from FFh to 00h in the general purpose RAM. On the ADuC845 however it is possible (by setting CFG845.7) to enable the 11-bit extended stack pointer. In this case the stack will rollover from FFh in RAM to 0100h in XRAM.

Preliminary Technical Data

ADuC845

The 11-bit stack pointer is visible in the SP and SPH SFRs. The SP SFR is located at 81h as with a standard 8052. The SPH SFR is located at B7h. The 3 LSBs of this SFR contain the 3 extra bits necessary to extend the 8-bit stack pointer into an 11-bit stack pointer.

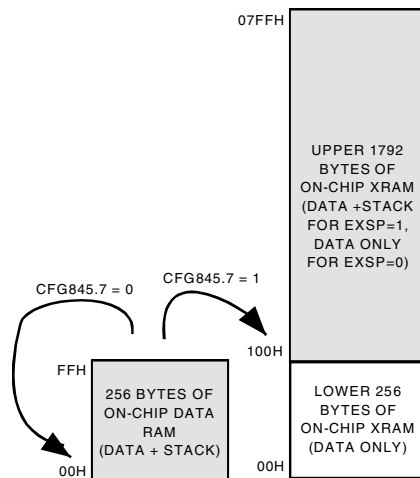

Figure 4. Extended Stack Pointer Operation

External Data Memory (External XRAM)

Just like a standard 8051 compatible core the ADuC845 can access external data memory using a MOVX instruction. The MOVX instruction automatically outputs the various control strobes required to access the data memory.

The ADuC845 however, can access up to 16MBytes of external data memory. This is an enhancement of the 64kBytes external data memory space available on a standard 8051 compatible core. The external data memory is discussed in more detail in the ADuC845 Hardware Design Considerations section.

SPECIAL FUNCTION REGISTERS (SFRs)

The SFR space is mapped into the upper 128 bytes of internal data memory space and accessed by direct addressing only. It provides an interface between the CPU and all on chip peripherals. A block diagram showing the programming model of the ADuC845 via the SFR area is shown in Figure 5.

All registers except the Program Counter (PC) and the four general-purpose register banks, reside in the SFR area. The SFR registers include control, configuration, and data registers that provide an interface between the CPU and all on-chip peripherals.

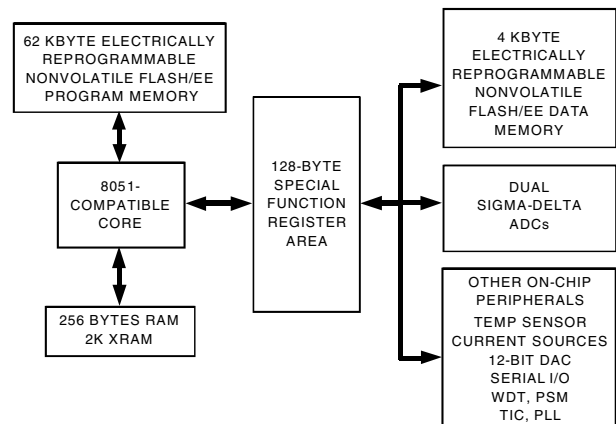

Figure 5. Programming Model

Accumulator SFR (ACC)

ACC is the Accumulator register and is used for math operations including addition, subtraction, integer multiplication and division, and Boolean bit manipulations. The mnemonics for accumulator-specific instructions refer to the Accumulator as A.

B SFR (B)

The B register is used with the ACC for multiplication and division operations. For other instructions it can be treated as a general-purpose scratchpad register.

Data Pointer (DPTR)

The Data Pointer is made up of three 8-bit registers, named DPP (page byte), DPH (high byte) and DPL (low byte). These are used to provide memory addresses for internal and external code access and external data access. It may be manipulated as a 16-bit register (DPTR = DPH, DPL), although INC DPTR instructions will automatically carry over to DPP, or as three independent 8-bit registers (DPP, DPH, DPL).

The ADuC845 supports dual data pointers. Refer to the Dual Data Pointer section later in this datasheet.

Stack Pointer (SP and SPH)

The SP SFR is the stack pointer and is used to hold an internal RAM address that is called the 'top of the stack.' The SP register is incremented before data is stored during PUSH and CALL executions. While the Stack may reside anywhere in on-chip RAM, the SP register is initialized to 07H after a reset. This causes the stack to begin at location 08H.

As mentioned earlier the ADuC845 offers an extended 11-bit stack pointer. The 3 extra bits to make up the 11-bit stack pointer are the 3 LSBs of the SPH byte located at B7h. To enable the SPH SFR the EXSP (CFG845.7) bit must be set otherwise the SPH SFR cannot be read or written to.

Preliminary Technical Data

ADuC845

Program Status Word (PSW)

The PSW SFR contains several bits reflecting the current status of the CPU as detailed in Table I.

SFR Address	D0H
Power ON Default Value	00H
Bit Addressable	Yes

Table I. PSW SFR Bit Designations

Bit	Name	Description
7	CY	Carry Flag
6	AC	Auxiliary Carry Flag
5	F0	General-Purpose Flag
4	RS1	Register Bank Select Bits
3	RS0	RS1 RS0 Selected Bank
		0 0 0
		0 1 1
		1 0 2
1 1 3		
2	OV	Overflow Flag
1	F1	General-Purpose Flag
0	P	Parity Bit

Power Control Register (PCON)

The PCON SFR contains bits for power-saving options and general-purpose status flags as shown in Table II.

SFR Address	87H
Power ON Default Value	00H
Bit Addressable	No

Table II. PCON SFR Bit Designations

Bit	Name	Description
7	SMOD	Double UART Baud Rate
6	SERIPD	SPI Power-Down Interrupt Enable
5	INT0PD	INT0 Power-Down Interrupt Enable
4	ALEOFF	Disable ALE Output
3	GF1	General-Purpose Flag Bit
2	GF0	General-Purpose Flag Bit
1	PD	Power-Down Mode Enable
0	IDL	Idle Mode Enable

845 Configuration Register (CFG845)

The CFG845 SFR contains the necessary bits to configure the internal XRAM and the extended SP. By default it configures the user into 8051 mode. i.e. extended SP is disabled, internal XRAM is disabled.

SFR Address	AFhH
Power ON Default Value	00H
Bit Addressable	No

Table III. CFG845 SFR Bit Designations

Bit	Name	Description
7	EXSP	Extended SP Enable. If this bit is set to 1 then the stack will rollover from SPH/SP = 00FFh to 0100h. If this bit is cleared to 0 then the SPH SFR will be disabled and the stack will rollover from SP=FFh to SP =00h
6	----	----
5	----	----
4	----	----
3	----	----
2	----	----
1	----	----
0	XRAMEN	XRAM Enable Bit If this bit is set to 1 then the internal XRAM will be mapped into the lower 2kBytes of the external address space. If this bit is cleared to 0 then the internal XRAM will not be accessible and the external data memory will be mapped into the lower 2kBytes of external data memory. (see figure 3).

Preliminary Technical Data

ADuC845

ADC CIRCUIT INFORMATION

The ADuC845 incorporates two (Primary & Auxiliary) 10-channel (8-channel on the MQFP package) 24-bit Σ - Δ ADCs. It also includes an on-chip programmable gain amplifier and digital filtering intended for the measurement of wide dynamic range, low frequency signals such as those in weigh-scale, strain-gauge, pressure transducer, or temperature measurement applications.

The ADuC845 can be configured as four/five fully-differential input channels or as eight/ten pseudo-differential input channels referenced to AINCOM. The primary ADC is buffered and can be programmed for one of eight input ranges from ± 20 mV to ± 2.56 V. Buffering the input channel means that the part can handle significant source impedances on the analog input and that R,C filtering (for noise rejection or RFI reduction) can be placed on the analog inputs if required. These input channels are intended to convert signals directly from sensors without the need for external signal conditioning.

Both ADCs employ a sigma-delta conversion technique to realize up to 24 bits of no missing codes performance (20Hz update rate, chop enabled). The sigma-delta modulator converts the sampled input signal into a digital pulse train whose duty cycle contains the digital information. A Sinc³ programmable low-pass filter is then employed to decimate the modulator output data stream to give a valid data conversion result at programmable output rates. The signal chain has two modes of operation, CHOP enabled and CHOP disabled. The $\overline{\text{CHOP}}$ bit in the ADCMODE register enables and disables the chopping scheme.

Signal Chain Overview (CHOP Enabled, $\overline{\text{CHOP}} = 0$)

With $\overline{\text{CHOP}} = 0$, chopping is enabled, this is the default and gives optimum performance in terms of drift performance. With chopping enabled, the available output rates vary from 5.35 Hz to 105 Hz. A block diagram of the ADC input channel with chop enabled is shown in Figure 7.

The sampling frequency of the modulator loop is many times higher than the bandwidth of the input signal. The integrator in the modulator shapes the quantization noise (which results from the analog-to-digital conversion) so that the noise is pushed toward one-half of the modulator frequency. The output of the sigma-delta modulator feeds directly into the digital filter. The digital filter then band-limits the response to a frequency significantly lower than one-half of the modulator frequency. In this manner, the 1-bit output of the comparator is translated into a band limited, low noise output from the ADuC845 ADC.

The ADuC845 filter is a low-pass, Sinc³ or $(\sin x/x)^3$ filter whose primary function is to remove the quantization noise introduced at the modulator. The cut-off frequency and decimated output data rate of the filter are programmable via the SF word loaded in the

filter register. The complete signal chain is chopped resulting in excellent dc offset and offset drift specifications and is extremely beneficial in applications where drift, noise rejection, and optimum EMI rejection are important factors.

With chopping, the ADC repeatedly reverses its inputs. The decimated digital output words from the Sinc³ filter, therefore, have a positive offset and negative offset term included. As a result, a final summing stage is included so that each output word from the filter is summed and averaged with the previous filter output to produce a new valid output result to be written to the ADC data register. The programming of the Sinc³ decimation factor is restricted to an 8-bit register called SF, the actual decimation factor is the register value times 8. The decimated output rate from the Sinc³ filter (and the ADC conversion rate) will therefore be:

$$f_{ADC} = \frac{1}{3} \times \frac{1}{8 \times SF} \times f_{MOD}$$

where

f_{ADC} is the ADC conversion rate.

SF is the decimal equivalent of the word loaded to the filter register.

f_{MOD} is the modulator sampling rate of 32.768 kHz.

The chop rate of the channel is half the output data rate:

$$f_{CHOP} = \frac{1}{2 \times f_{ADC}}$$

As shown in the block diagram, the Sinc³ filter outputs alternately contain $+V_{OS}$ and $-V_{OS}$, where V_{OS} is the respective channel offset. This offset is removed by performing a running average of two. This average by two means that the settling time to any change in programming of the ADC will be twice the normal conversion time, while an asynchronous step change on the analog input will not be fully reflected until the third subsequent output.

$$t_{SETTLE} = \frac{2}{f_{ADC}} = 2 \times t_{ADC}$$

The allowable range for SF (Chop Enabled) is 13 to 255 with a default of 69 (45H). The corresponding conversion rates, RMS and Pk-Pk noise performances are shown in Table V & Table VI. Note that the conversion time increases by 0.732 ms for each increment in SF.

With chopping enabled the ADC noise performance is the same as that of the ADuC834.

TABLE V: Typical Output rms noise (μ V) vs Input Range and Update Rate for the ADuC845 with chopping Enabled.

SF Word	Data Update Rate (Hz)	Input Range							
		± 20 mV	± 40 mV	± 80 mV	± 160 mV	± 320 mV	± 640 mV	± 1.28 V	± 2.56 V
13	105.03	1.50	1.50	1.60	1.75	3.50	4.50	6.70	11.75
69	19.79	0.60	0.65	0.65	0.65	0.65	0.95	1.40	2.30
255	5.35	0.35	0.35	0.37	0.37	0.37	0.51	0.82	1.25

TABLE VI: Peak to Peak Resolution (bits) vs Input Range and Update Rate for the ADuC845 with chopping Enabled.

SF Word	Data Update Rate (Hz)	Input Range							
		±20 mV	±40 mV	±80 mV	±160 mV	±320 mV	±640 mV	±1.28 V	±2.56 V
13	105.03	12	13	14	15	15	15.5	16	16
69	19.79	13.5	14	15	16	17	17.5	18	18.5
255	5.35	14	15	16	17	18	18.5	19	19.5

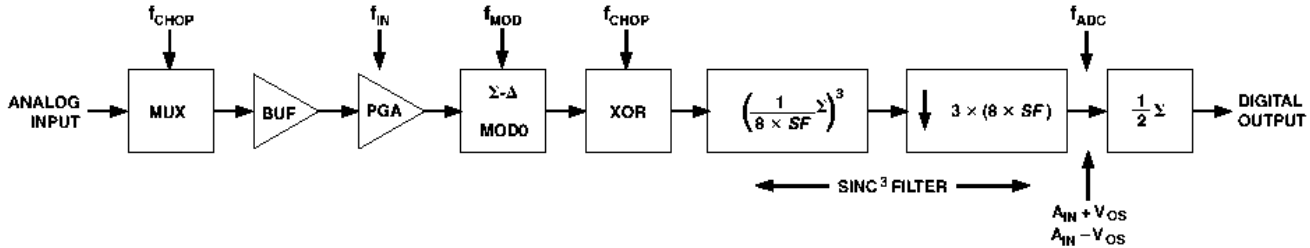

Figure 7: ADC Circuit Diagram with Chopping Enabled

Signal Chain Overview (CHOP Disabled, $\overline{\text{CHOP}} = 1$)

With CHOP = 1 chopping is disabled. With chopping disabled the available output rates vary from 16.06 Hz to 1.365 kHz. The range of applicable SF words is from 3 to 255. When switching between channels with chop disabled, the channel throughput rate is increased over the case where chop is enabled. The drawback with chop disabled is that the drift performance is degraded and calibration is required following a gain change or significant temperature change. A block diagram of the ADC input channel with chop disabled is shown in Figure 8. The signal chain includes a multiplexer, buffer, PGA, sigma-delta modulator, and digital filter. The modulator bit stream is applied to a Sinc³ filter. The programming of the Sinc³ decimation factor is restricted to an 8-bit register SF, the actual decimation factor is the register value times 8. The decimated output rate from the Sinc³ filter (and the ADC conversion rate) will therefore be:

$$f_{ADC} = \frac{1}{8 \times SF} \times f_{MOD}$$

where

f_{ADC} is the ADC conversion rate,

SF is the decimal equivalent of the word loaded to the filter register, valid range is from 3 to 255,

f_{MOD} is the modulator sampling rate of 32.768 kHz.

The settling time to a step input is governed by the digital filter. A synchronized step change will require a settling time of three times the programmed update rate, a channel change can be treated as a synchronized step change. This means that following a synchronized step change, the ADC will require three outputs before the result accurately reflects the new input voltage.

$$t_{SETTLE} = \frac{3}{f_{ADC}} = 3 \times t_{ADC}$$

An unsynchronized step change will require four outputs to accurately reflect the new analog input at its output.

The allowable range for SF is 3 to 255 with a default of 69 (45H). The corresponding conversion rates, RMS and Pk-Pk noise performances are shown in Table VII & Table VIII. Note that the conversion time increases by 0.244 ms for each increment in SF.

ADC NOISE PERFORMANCE WITH CHOPPING DISABLED

Tables VII and VIII show the output rms noise and output peak-to-peak resolution in bits (rounded to the nearest 0.5 LSB) for some typical output update rates. The numbers are typical and generated at a differential input voltage of 0V. The output update rate is selected via the SF7–SF0 bits in the SF Filter Register. It is important to note that the peak-to-peak resolution figures represent the resolution for which there will be no code flicker within a six-sigma limit. The output noise comes from two sources. The first is the electrical noise in the semiconductor devices (device noise) used in the implementation of the modulator. Secondly, when the analog input is converted to the digital domain, quantization noise is added. The device noise is at a low level and is independent of frequency. The quantization noise starts at an even lower level but rises rapidly with increasing frequency to become the dominant noise source. The numbers in the tables are given for the bipolar input ranges. For the unipolar ranges the rms noise numbers will be the same as the bipolar range, but the peak-to-peak resolution is now based on half the signal range which effectively means losing 1 bit of resolution. Typically, the performance of the ADC with Chop disabled will show a 1LSB degradation over the performance with Chop enabled.

TABLE VII: Typical Output rms noise (μV) vs Input Range and Update Rate for the ADuC845 with chopping disabled.

SF Word	Data Update Rate (Hz)	Input Range							
		$\pm 20\text{ mV}$	$\pm 40\text{ mV}$	$\pm 80\text{ mV}$	$\pm 160\text{ mV}$	$\pm 320\text{ mV}$	$\pm 640\text{ mV}$	$\pm 1.28\text{ V}$	$\pm 2.56\text{ V}$
3	1365.0	2.47	2.49	2.37	3.87	7.18	12.61	16.65	32.45
69	59.36	0.961	0.971	0.949	0.922	0.923	1.32	2.03	3.73
255	16.06	0.475	0.468	0.434	0.485	0.458	0.688	1.18	1.78

TABLE VIII: Peak to Peak Resolution (bits) vs Input Range and Update Rate for the ADuC845 with chopping disabled.

SF Word	Data Update Rate (Hz)	Input Range							
		$\pm 20\text{ mV}$	$\pm 40\text{ mV}$	$\pm 80\text{ mV}$	$\pm 160\text{ mV}$	$\pm 320\text{ mV}$	$\pm 640\text{ mV}$	$\pm 1.28\text{ V}$	$\pm 2.56\text{ V}$
3	1365.0	11	12	14	14	14	14	15	15
69	59.36	13	14	15	16	17	17	18	18
255	16.06	14	15	16	17	18	18	19	19

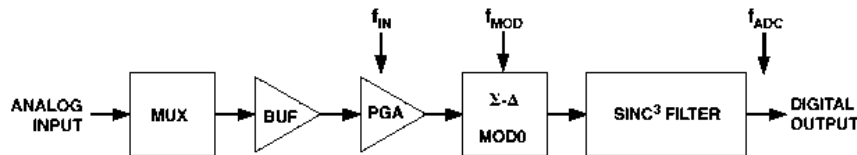

Figure: 8 ADC Circuit with CHOP disabled

Table IX Auxiliary ADC

Typical Output RMS Noise vs Update Rate*

Output RMS Noise in μV

SF Word	Data Update Rate (Hz)	Input Range 2.5v
13	105.3	10.75
69	19.79	2.00
255	5.35	1.15

* ADC converting in Bipolar Mode

Peak-to-Peak Resolution vs. Update Rate¹

Peak-to-Peak Resolution in Bits

SF Word	Data Update Rate (Hz)	Input Range 2.5v
13	105.3	16 ²
69	19.79	16
255	5.35	16

¹ ADC converting in Bipolar Mode

² In Unipolar mode, peak-to-peak resolution at 105Hz is 15 bits

Reference Inputs

The ADuC845 has two separate differential reference inputs REFIN+/- and REFIN2+/- . While both references are available for use with the primary ADC only the REFIN+/- is available for the auxiliary ADC. The common mode range for these differential references is from AGND to AV_{DD} . The nominal external reference voltage is 2.5v, with the primary and auxiliary reference select bits configured from the ADC0CON2 and ADC1CON respectively.

The ADuC845 can also be configured to use the on-chip band-gap reference, via the XREF0/1 bits in the ADC0CON2 SFR (for primary ADC) or the AXREF bit in ADC1CON (for auxiliary ADC). In this mode of operation the ADCs will see the internal reference of 1.25v, thereby halving all the input ranges. A consequence of using the internal bandgap reference is a noticeable degradation in peak-to-peak resolution. For this reason operation with an external reference is strongly recommended.

In applications where the excitation (voltage or current) for the transducer on the analog input also drives the reference inputs for the part, the effect of the of any low frequency noise in the excitation source will be removed as the application is ratiometric. If the ADuC845 is not used in a ratiometric configuration then a low noise reference should be used. Recommended references voltage sources for the ADuC845 include ADR421, REF43, REF192.

It should also be noted that the reference inputs provide a high impedance, dynamic load to external connections. Because the impedance of each reference input is dynamic, resistor/capacitor combinations on these pins can cause dc gain errors depending on the output impedance of the source that is driving the referenc inputs. Reference voltage sources, like those mentioned above (e.g. ADR421), will typically have low output impedances and therefore decoupling capacitors of the REFIN+/- or REFIN2+/- inputs would be recommended. Deriving the reference voltage from an external

resistor configuration will mean that the reference input sees a significant external source impedance. External decoupling of the REFIN+/- and/or REFIN2+/- inputs would not be recommended in this type of configuration.

Burnout Current Sources

The Primary ADC on the ADuC845 incorporates two 200 μ A constant current generators, one sourcing current from the AV_{DD} to AIN(+), and one sinking current from AIN(-) to AGND. These currents are only configurable for use on AIN4 \rightarrow AIN5 and/or AIN6 \rightarrow AIN7 in differential mode only, from the BO bit in the ICON SFR. These burnout current sources are also only available with full buffering enabled via the BUF0/BUF1 bits in the ADC0CON1 SFR. Once the burnout currents are turned on, a current will flow in the external transducer circuit, and a measurement of the input voltage on the analog input channel can be taken. If the resulting voltage measured is fullscale, it indicates that the transducer has gone open-circuit. If the voltage measured is 0v, it indicates that the transducer has gone short circuit. The current sources work over the normal absolute input voltage range specifications.

Reference Detect Circuit

The main and auxiliary ADC's have the option of using the internal bandgap reference or an external reference applied to the two REFIN pins, by means of the XREF0/1 bits in their respective control registers AD0CON2 and AD1CON. A reference detection circuit is provided to detect whether there is a valid voltage applied to the REFIN+/- pins. This feature arose in connection with strain

gauge sensors in weigh-scales where the reference and signal are provided via a cable from the remote sensor. It is desirable to detect whether the cable is disconnected. If either of the pins is floating or if the applied voltage is below a specified threshold then a flag (NOXREF) is set in the ADC status register (ADCSTAT), conversion results are clamped and calibration registers are not updated if a calibration is in progress.

Note: the reference-detect does not look at Refin2+/-.

Sinc Filter Register (SF)

The number entered into this register, when left shifted by 3 bits sets the decimation factor of the Sinc³ Filter for the ADC.

The range of operation of the SF word depends on whether ADC Chop is on or off. With Chop off the minimum SF word is 3 and the maximum is 255. This gives an ADC throughput rate from 16.06 Hz to 1.365kHz. With Chop on the minimum SF word is 13 (all values lower than 13 are clamped to 13) and the maximum is 255. This gives an ADC throughput rate from 5.4Hz to 105Hz. See f_{adc} equations in the ADC description section above.

There is one additional feature of the Sinc³ Filter, and that is a second notch filter positioned in the frequency response at 60Hz. This gives simultaneous 50Hz & 60Hz rejection.

This 60Hz filter is enabled via the REJ60 bit in the ADCMODE register (ADCMODE.6). This notch is only valid for SF words \geq 68, otherwise ADC errors will occur. This function is only useful with an ADC clock of 32.768kHz.

During Calibration the current (user written) value of the SF register is used.

ADC SFR INTERFACE

Both ADCs are controlled and configured via a number of SFRs that are mentioned here and described in more detail in the following pages.

ADCSTAT:	ADC Status Register. Holds general status of the Primary and Auxiliary ADCs.
ADCMODE:	ADC Mode Register. Controls general modes of operation for Primary and Auxiliary ADCs.
ADC0CON1:	Primary ADC Control Register 1. Controls specific configuration of Primary ADC.
ADC0CON2:	Primary ADC Control Register 2. Controls specific configuration of Primary ADC.
ADC1CON:	Auxiliary ADC Control Register. Controls specific configuration of Auxiliary ADC.
SF:	Sinc Filter Register. Configures the decimation factor for the Sinc ³ filter and thus the Primary and Auxiliary ADC update rates.
ICON:	Current Source Control Register. Allows user control of the various on-chip current source options.
ADC0L/M/H:	Primary ADC 24-bit conversion result is held in these three 8-bit registers.
ADC1L/M/H:	Auxiliary ADC 24-bit conversion result is held in these two 8-bit registers.
OF0L/M/H:	Primary ADC 24-bit Offset Calibration Coefficient is held in these three 8-bit registers.
OF1L/H:	Auxiliary ADC 16-bit Offset Calibration Coefficient is held in these two 8-bit registers.
GN0L/M/H:	Primary ADC 24-bit Gain Calibration Coefficient is held in these three 8-bit registers.
GN1L/H:	Auxiliary ADC 16-bit Gain Calibration Coefficient is held in these two 8-bit registers.

Preliminary Technical Data

ADuC845

ADCSTAT—(ADC Status Register)

This SFR reflects the status of both ADCs including data ready, calibration, and various (ADC-related) error and warning conditions including Refin+/- reference detect and conversion overflow/underflow flags.

SFR Address D8H
Power-On Default Value 00H
Bit Addressable Yes

Table X. ADCSTAT SFR Bit Designations

Bit	Name	Description
7	RDY0	Ready Bit for Primary ADC. <i>Set</i> by hardware on completion of ADC conversion or calibration cycle. <i>Cleared</i> directly by the user or indirectly by write to the mode bits to start another Primary ADC conversion or calibration. The Primary ADC is inhibited from writing further results to its data or calibration registers until the RDY0 bit is cleared.
6	RDY1	Ready Bit for Auxiliary ADC. Same definition as RDY0 referred to the Auxiliary ADC.
5	CAL	Calibration Status Bit. <i>Set</i> by hardware on completion of calibration. <i>Cleared</i> indirectly by a write to the mode bits to start another ADC conversion or calibration.
4	NOXREF	No External Reference Bit (<i>only active if Primary or Auxiliary ADC is active</i>). <i>Set</i> to indicate that one or both of the REFIN pins is floating or the applied voltage is below a specified threshold. When Set, conversion results are clamped to all ones. Only detects invalid Refin+/-, does not check Refin2+/-. <i>Cleared</i> to indicate valid VREF.
3	ERR0	Primary ADC Error Bit. <i>Set</i> by hardware to indicate that the result written to the Primary ADC data registers has been clamped to all zeros or all ones. After a calibration, this bit also flags error conditions that caused the calibration registers not to be written. <i>Cleared</i> by a write to the mode bits to initiate a conversion or calibration.
2	ERR1	Auxiliary ADC Error Bit. Same definition as ERR0 referred to the Auxiliary ADC.
1	---	Reserved for Future Use
0	---	Reserved for Future Use

Preliminary Technical Data

ADuC845

ADCMODE (ADC Mode Register)

Used to control the operational mode of both ADCs.

SFR Address D1H
 Power-On Default Value 10H
 Bit Addressable No

Table XI. ADCMODE SFR Bit Designations

Bit	Name	Description
7	—	Reserved for Future Use
6	REJ60	Automatic 60 Hz notch select bit. Setting this bit will place a notch in the frequency response at 60Hz, allowing simultaneous 50 & 60Hz rejection at an SF word of 82. This 60Hz notch can only be set if SF ≥ 68. This second notch is only placed at 60Hz if the ADC clock is at 32.768kHz.
5	ADC0EN	Primary ADC Enable. Set by the user to enable the Primary ADC and place it in the mode selected in MD2–MD0 below. Cleared by the user to place the Primary ADC in power-down mode.
4	ADC1EN	Auxiliary ADC Enable. Set by the user to enable the Auxiliary ADC and place it in the mode selected in MD2–MD0 below. Cleared by the user to place the Auxiliary ADC in power-down mode.
3	CHOP	Chop Mode Disable Set by the user to disable Chop Mode on both the Primary and Auxiliary ADC allowing greater ADC data throughput . Cleared by the user to enable Chop Mode on both the Primary and Auxiliary ADC.
2	MD2	Primary and Auxiliary ADC Mode bits. These bits select the operational mode of the enabled ADC as follows: MD2 MD1 MD0
1	MD1	
0	MD0	
		0 0 0 ADC Power-Down Mode (Power-On Default)
		0 0 1 Idle Mode. In Idle Mode, the ADC filter and modulator are held in a reset state although the modulator clocks are still provided.
		0 1 0 Single Conversion Mode In Single Conversion Mode, a single conversion is performed on the enabled ADC. On completion of a conversion, the ADC data registers(ADC0H/M/L and/or ADC1H/M/L) are updated. The relevant flags in the ADCSTAT SFR are written, and power-down is re-entered with the MD2–MD0 accordingly being written to 000.
		0 1 1 Continuous Conversion In Continuous Conversion Mode, the ADC data registers are regularly updated at the selected update rate (see SF Register).
		1 0 0 Internal Zero-Scale Calibration Internal short automatically connected to the enabled ADC input(s)
		1 0 1 Internal Full-Scale Calibration Internal or External REFIN+/- or REFIN2+/- VREF(as determined by XREF bits in ADC0CON2 and/or AXREF in ADC1CON) is automatically connected to the enabled ADC input(s) for this calibration.
		1 1 0 System Zero-Scale Calibration User should connect system zero-scale input to the enabled ADC input(s) as selected by CH3-CH0 and ACH3-ACH0 bits in the ADC0CON2 and ADC1CON Registers.
		1 1 1 System Full-Scale Calibration User should connect system full-scale input to the enabled ADC input(s) as selected by CH3-CH0 and ACH3-ACH0 bits in the ADC0CON2 and ADC1CON Registers.

NOTES

- Any change to the MD bits will immediately reset both ADCs. A write to the MD2–0 Bits with no change is also treated as a reset. (See exception to this in Note 3 below.)
- If ADC0CON is written when ADC0EN = 1, or if ADC0EN is changed from 0 to 1, then both ADCs are also immediately reset. In other words, the Primary ADC is given priority over the Auxiliary ADC and any change requested on the primary ADC is immediately responded to.
- On the other hand, if ADC1CON is written or if ADC1EN is changed from 0 to 1, only the Auxiliary ADC is reset. For example, if the Primary ADC is continuously converting when the Auxiliary ADC change or enable occurs, the primary ADC continues undisturbed. Rather than allow the Auxiliary ADC to operate with a phase difference from the primary ADC, the Auxiliary ADC will fall into step with the outputs of the primary ADC. The result is that the first conversion time for the Auxiliary ADC will be delayed up to three outputs while the Auxiliary ADC update rate is synchronized to the Primary ADC.
- Once ADCMODE has been written with a calibration mode, the RDY0/1 bits (ADCSTAT) are reset and the calibration commences. On completion, the appropriate calibration registers are written, the relevant bits in ADCSTAT are written, and the MD2–0 bits are reset to 000 to indicate the ADC is back in power-down mode.
- Any calibration request of the Auxiliary ADC while the temperature sensor is selected will fail to complete. Although the RDY1 bit will be set at the end of the calibration cycle, no update of the calibration SFRs will take place and the ERR1 bit will be set.
- Calibrations are performed at maximum SF (see SF SFR) value guaranteeing optimum calibration operation.

ADC0CON1 (Primary ADC Control Register)

ADC0CON is used to configure the Primary ADC for Buffer, unipolar or bipolar coding and ADC range configuration.

ADC0CON1 Primary ADC Control SFR

SFR Address D2H
 Power-On Default Value 07H
 Bit Addressable No

Table XII. ADC0CON1 SFR Bit Designations

Bit	Name	Description																																				
7	BUF1	Buffer Configuration Bits																																				
6	BUF0	<table border="0"> <tr> <td>BUF1</td> <td>BUF0</td> <td>Buffer Configuration</td> </tr> <tr> <td>0</td> <td>0</td> <td>ADC0+ and ADC0- are buffered</td> </tr> <tr> <td>0</td> <td>1</td> <td>ADC0+ only buffered</td> </tr> <tr> <td>1</td> <td>0</td> <td>Buffer Bypass</td> </tr> <tr> <td>1</td> <td>1</td> <td>Reserved for Future Use.</td> </tr> </table>	BUF1	BUF0	Buffer Configuration	0	0	ADC0+ and ADC0- are buffered	0	1	ADC0+ only buffered	1	0	Buffer Bypass	1	1	Reserved for Future Use.																					
BUF1	BUF0	Buffer Configuration																																				
0	0	ADC0+ and ADC0- are buffered																																				
0	1	ADC0+ only buffered																																				
1	0	Buffer Bypass																																				
1	1	Reserved for Future Use.																																				
5	UNI	Primary ADC Unipolar Bit. <i>Set</i> by user to enable unipolar coding, i.e., zero differential input will result in 0x000000 output. <i>Cleared</i> by user to enable bipolar coding, zero differential input will result in 0x800000 output.																																				
4	—	Reserved for Future Use																																				
3	—	Reserved for Future Use																																				
2	RN2	Primary ADC Range Bits. Written by the user to select the Primary ADC input range as follows:																																				
1	RN1	<table border="0"> <tr> <td>RN2</td> <td>RN1</td> <td>RN0</td> <td>Selected Primary ADC Input Range (VREF = 2.5 V)</td> </tr> <tr> <td>0</td> <td>0</td> <td>0</td> <td>±20 mV (0 mV–20 mV in Unipolar Mode)</td> </tr> <tr> <td>0</td> <td>0</td> <td>1</td> <td>±40 mV (0 mV–40 mV in Unipolar Mode)</td> </tr> <tr> <td>0</td> <td>1</td> <td>0</td> <td>±80 mV (0 mV–80 mV in Unipolar Mode)</td> </tr> <tr> <td>0</td> <td>1</td> <td>1</td> <td>±160 mV (0 mV–160 mV in Unipolar Mode)</td> </tr> <tr> <td>1</td> <td>0</td> <td>0</td> <td>±320 mV (0 mV–320 mV in Unipolar Mode)</td> </tr> <tr> <td>1</td> <td>0</td> <td>1</td> <td>±640 mV (0 mV–640 mV in Unipolar Mode)</td> </tr> <tr> <td>1</td> <td>1</td> <td>0</td> <td>±1.28 V (0 V–1.28 V in Unipolar Mode)</td> </tr> <tr> <td>1</td> <td>1</td> <td>1</td> <td>±2.56 V (0 V–2.56 V in Unipolar Mode)</td> </tr> </table>	RN2	RN1	RN0	Selected Primary ADC Input Range (VREF = 2.5 V)	0	0	0	±20 mV (0 mV–20 mV in Unipolar Mode)	0	0	1	±40 mV (0 mV–40 mV in Unipolar Mode)	0	1	0	±80 mV (0 mV–80 mV in Unipolar Mode)	0	1	1	±160 mV (0 mV–160 mV in Unipolar Mode)	1	0	0	±320 mV (0 mV–320 mV in Unipolar Mode)	1	0	1	±640 mV (0 mV–640 mV in Unipolar Mode)	1	1	0	±1.28 V (0 V–1.28 V in Unipolar Mode)	1	1	1	±2.56 V (0 V–2.56 V in Unipolar Mode)
RN2	RN1	RN0	Selected Primary ADC Input Range (VREF = 2.5 V)																																			
0	0	0	±20 mV (0 mV–20 mV in Unipolar Mode)																																			
0	0	1	±40 mV (0 mV–40 mV in Unipolar Mode)																																			
0	1	0	±80 mV (0 mV–80 mV in Unipolar Mode)																																			
0	1	1	±160 mV (0 mV–160 mV in Unipolar Mode)																																			
1	0	0	±320 mV (0 mV–320 mV in Unipolar Mode)																																			
1	0	1	±640 mV (0 mV–640 mV in Unipolar Mode)																																			
1	1	0	±1.28 V (0 V–1.28 V in Unipolar Mode)																																			
1	1	1	±2.56 V (0 V–2.56 V in Unipolar Mode)																																			
0	RN0																																					

Preliminary Technical Data

ADuC845

ADC0CON2 (Primary ADC Channel Select Register)

ADC0CON2 is used to select the channel for the Primary ADC

ADC0CON2 Primary ADC Channel Select Register

SFR Address E6H
 Power-On Default Value 00H
 Bit Addressable No

Table XIII. ADC0CON2 SFR Bit Designations

Bit	Name	Description																																																																																					
7	XREF1	Primary ADC External Reference Select Bit.																																																																																					
6	XREF0	<p>Set by user to enable the Primary ADC to use the external reference via REFIN+/- or REFIN2+/-.</p> <p>Cleared by user to enable the Primary ADC to use the internal bandgap reference (VREF = 1.25 V).</p> <table border="1"> <thead> <tr> <th>XREF1</th> <th>XREF0</th> <th></th> </tr> </thead> <tbody> <tr> <td>0</td> <td>0</td> <td>Internal 1.25v Vref</td> </tr> <tr> <td>0</td> <td>1</td> <td>Refin+/-</td> </tr> <tr> <td>1</td> <td>0</td> <td>Refin2+/- (Ain2 / Ain3)</td> </tr> <tr> <td>1</td> <td>1</td> <td>Reserved for Future Use</td> </tr> </tbody> </table>	XREF1	XREF0		0	0	Internal 1.25v Vref	0	1	Refin+/-	1	0	Refin2+/- (Ain2 / Ain3)	1	1	Reserved for Future Use																																																																						
XREF1	XREF0																																																																																						
0	0	Internal 1.25v Vref																																																																																					
0	1	Refin+/-																																																																																					
1	0	Refin2+/- (Ain2 / Ain3)																																																																																					
1	1	Reserved for Future Use																																																																																					
5	—	Reserved for Future Use																																																																																					
4	—	Reserved for Future Use																																																																																					
3	CH3	Primary ADC Channel Select Bits. Written by the user to select the Primary ADC Channel as follows <table border="1"> <thead> <tr> <th>CH3</th> <th>CH2</th> <th>CH1</th> <th>CH0</th> <th>Selected Primary ADC Input Channel.</th> </tr> </thead> <tbody> <tr> <td>0</td> <td>0</td> <td>0</td> <td>0</td> <td>AIN0 → AINCOM</td> </tr> <tr> <td>0</td> <td>0</td> <td>0</td> <td>1</td> <td>AIN1 → AINCOM</td> </tr> <tr> <td>0</td> <td>0</td> <td>1</td> <td>0</td> <td>AIN2 → AINCOM</td> </tr> <tr> <td>0</td> <td>0</td> <td>1</td> <td>1</td> <td>AIN3 → AINCOM</td> </tr> <tr> <td>0</td> <td>1</td> <td>0</td> <td>0</td> <td>AIN4 → AINCOM</td> </tr> <tr> <td>0</td> <td>1</td> <td>0</td> <td>1</td> <td>AIN5 → AINCOM</td> </tr> <tr> <td>0</td> <td>1</td> <td>1</td> <td>0</td> <td>AIN6 → AINCOM</td> </tr> <tr> <td>0</td> <td>1</td> <td>1</td> <td>1</td> <td>AIN7 → AINCOM</td> </tr> <tr> <td>1</td> <td>0</td> <td>0</td> <td>0</td> <td>AIN8 → AINCOM (CSP package only). Not a valid selection on MQFP package.</td> </tr> <tr> <td>1</td> <td>0</td> <td>0</td> <td>1</td> <td>AIN9 → AINCOM (CSP package only). Not a valid selection on MQFP package.</td> </tr> <tr> <td>1</td> <td>0</td> <td>1</td> <td>0</td> <td>AIN0 → AIN1</td> </tr> <tr> <td>1</td> <td>0</td> <td>1</td> <td>1</td> <td>AIN2 → AIN3</td> </tr> <tr> <td>1</td> <td>1</td> <td>0</td> <td>0</td> <td>AIN4 → AIN5</td> </tr> <tr> <td>1</td> <td>1</td> <td>0</td> <td>1</td> <td>AIN6 → AIN7</td> </tr> <tr> <td>1</td> <td>1</td> <td>1</td> <td>0</td> <td>AIN8 → AIN9 (CSP package only). Mot a valid selection on MQFP package.</td> </tr> <tr> <td>1</td> <td>1</td> <td>1</td> <td>1</td> <td>AINCOM → AINCOM</td> </tr> </tbody> </table>	CH3	CH2	CH1	CH0	Selected Primary ADC Input Channel.	0	0	0	0	AIN0 → AINCOM	0	0	0	1	AIN1 → AINCOM	0	0	1	0	AIN2 → AINCOM	0	0	1	1	AIN3 → AINCOM	0	1	0	0	AIN4 → AINCOM	0	1	0	1	AIN5 → AINCOM	0	1	1	0	AIN6 → AINCOM	0	1	1	1	AIN7 → AINCOM	1	0	0	0	AIN8 → AINCOM (CSP package only). Not a valid selection on MQFP package.	1	0	0	1	AIN9 → AINCOM (CSP package only). Not a valid selection on MQFP package.	1	0	1	0	AIN0 → AIN1	1	0	1	1	AIN2 → AIN3	1	1	0	0	AIN4 → AIN5	1	1	0	1	AIN6 → AIN7	1	1	1	0	AIN8 → AIN9 (CSP package only). Mot a valid selection on MQFP package.	1	1	1	1	AINCOM → AINCOM
CH3	CH2		CH1	CH0	Selected Primary ADC Input Channel.																																																																																		
0	0		0	0	AIN0 → AINCOM																																																																																		
0	0		0	1	AIN1 → AINCOM																																																																																		
0	0		1	0	AIN2 → AINCOM																																																																																		
0	0		1	1	AIN3 → AINCOM																																																																																		
0	1		0	0	AIN4 → AINCOM																																																																																		
0	1		0	1	AIN5 → AINCOM																																																																																		
0	1		1	0	AIN6 → AINCOM																																																																																		
0	1		1	1	AIN7 → AINCOM																																																																																		
1	0	0	0	AIN8 → AINCOM (CSP package only). Not a valid selection on MQFP package.																																																																																			
1	0	0	1	AIN9 → AINCOM (CSP package only). Not a valid selection on MQFP package.																																																																																			
1	0	1	0	AIN0 → AIN1																																																																																			
1	0	1	1	AIN2 → AIN3																																																																																			
1	1	0	0	AIN4 → AIN5																																																																																			
1	1	0	1	AIN6 → AIN7																																																																																			
1	1	1	0	AIN8 → AIN9 (CSP package only). Mot a valid selection on MQFP package.																																																																																			
1	1	1	1	AINCOM → AINCOM																																																																																			
2	CH2																																																																																						
1	CH1																																																																																						
0	CH0																																																																																						

Preliminary Technical Data

ADuC845

ADC1CON (Auxiliary ADC Control Register)

ADC1CON is used to configure the Auxiliary ADC for reference and channel selection and unipolar or bipolar coding.

ADC1CON Auxiliary ADC Control SFR

SFR Address D3H
 Power-On Default Value 00H
 Bit Addressable No

Table XIV. ADC1CON SFR Bit Designations

Bit	Name	Description	
7	—	Reserved for Future Use	
6	AXREF	Auxiliary ADC External Reference Bit. <i>Set</i> by user to enable the Auxiliary ADC to use the external reference via REFIN(+)/REFIN(-). <i>Cleared</i> by user to enable the Auxiliary ADC to use the internal bandgap reference.	
5	AUNI	Auxiliary ADC Unipolar Bit. <i>Set</i> by user to enable unipolar coding, i.e., zero input will result in 0x000000 output. <i>Cleared</i> by user to enable bipolar coding, zero input will result in 0x800000 output.	
4	—	Reserved for Future Use	
3	ACH3	Auxiliary ADC Channel Select Bits. Written by the user to select the Auxiliary ADC Channel Selected Auxiliary ADC Input Range (VREF = 2.5 V)	
2	ACH2		
1	ACH1		
0	ACH0		0 0 0 0 AIN0 → AINCOM
			0 0 0 1 AIN1 → AINCOM
			0 0 1 0 AIN2 → AINCOM
			0 0 1 1 AIN3 → AINCOM
			0 1 0 0 AIN4 → AINCOM
			0 1 0 1 AIN5 → AINCOM
		0 1 1 0 AIN6 → AINCOM	
0 1 1 1 AIN7 → AINCOM			
		1 0 0 0 AIN8 → AINCOM (CSP package only). Not a valid selection on MQFP package	
		1 0 0 1 AIN9 → AINCOM (CSP package only). Not a valid selection on MQFP package	
		1 0 1 0 AIN0 → AIN1	
		1 0 1 1 AIN2 → AIN3	
		1 1 0 0 AIN4 → AIN5	
		1 1 0 1 AIN6 → AIN7	
		1 1 1 0 TEMPERATRE SENSOR ^{1,2,3} .	
		1 1 1 1 AINCOM → AINCOM	

NOTES

1. When the temperature sensor is selected, user code must select internal reference via AXREF bit above and clear the AUNI bit (ADC1CON.5) to select bipolar coding.
2. The temperature sensor is factory calibrated to yield conversion results 0x800000 at 0 °C (ADC Chop on).
3. A +1°C change in temperature will result in a +1 LSB change in the ADC1H Register ADC conversion result.

Preliminary Technical Data

ADuC845

I²C SERIAL INTERFACE

The ADuC845 supports a fully licenced* I²C serial interface. The I²C interface is implemented as a full hardware slave and software master. SDATA (pin 27 on MQFP package and pin 29 on CSP package) is the data I/O pin and SCLK (pin 26 on MQFP package and pin 28 on CSP package). The I²C interface on the ADuC845 is fully independent of all other pin/function multiplexing. The I²C interface incorporated on the ADuC845 also includes a second address register (I2CADD1) at SFR address 0xF2 with a default

power on value of 0x7F. The I²C interface is always available to the user and is not multiplexed with any other I/O functionality on the chip. This means that on the ADuC845 the I²C and SPI interfaces can be used at the same time. When using the I²C and SPI interfaces simultaneously, because they both utilize the same interrupt routine (vector address 0x3B), when an interrupt occurs from one of these it will be necessary to interrogate each interface to see which one has triggered the ISR request.

Four SFRs are used to control the I²C interface. These are described below.

I2CCON	I²C Control Register
Function	I ² C control register.
SFR Address	0xE8
Power-On Default value	0x00
Bit Addressable	Yes

Table XV. I2CCON SFR Bit Designations

Bit	Name	Description
7	MDO	I ² C Software Master Data Output Bit (Master Mode Only). This data bit is used to implement a master I ² C transmitter interface in software. Data writted to this bit will be Outputted on the SDATA pin if the data output enable bit (MDE) is set.
6	MDE	I ² C Software Output Enable Bit (Master Mode only) Set by the user to enable the SDATA pin as an output (Tx). Cleared by the user to enable the SDATA pin as an input (Rx)
5	MCO	I ² C Software Master Clock Output Bit (Master Mode only) This bit is used to implement the SCLK for a master I ² C transmitter in software. Data written to this bit will be outputted on the SCLK pin.
4	MDI	I ² C Software Master Data Input Bit (Master Mode only) This data bit is used to implement a master I ² C receiver interface in software. Data on the SDATA pin is latched into this bit on an SCLK transition if the data output enable (MDE) bit is 0.
3	I2CM	I ² C Master/Slave mode bit Set by the user to enable I ² C software master mode. Cleared by user to enable I ² C hardware slave mode.
2	I2CRS	I ² C Reset Bit (Slave Mode only) Set by the user to reset the I ² C interface. Cleared by user code for normal I ² C operation.
1	I2CTX	I ² C Direction Transfer Bit (Slave Mode only) Set by the MicroConverter is the I ² C interface is transmitting. Cleared by the MicroConverter is the I ² C interface is receiving.
0	I2CI	I ² C Interrupt bit (Slave Mode only) Set by the MicroConverter after a byte has been transmitted or received. Cleared by the MicroConverter when the user code reads the I2CDAT SFR. I2CI should not be cleared by user code.

I2CADD	I²C Address Register 1
Function	Holds one of the I ² C peripheral addresses for the part. It may be overwritten by user code. Application note uC001 at http://www.analog.com/microconverter describes the format of the I ² C standard 7-bit address.
SFR Address	0x9B
Power-On Default value	0x55
Bit Addressable	No

I2CADD1	I²C Address Register 2
Function	As for I2CADD described above.
SFR Address	0xF2
Power On Default value	0x7F
Bit Addressable	No

* Purchase of licensed I²C components of Analog Devices or one of its sublicensed Associated Companies conveys a license for the purchaser under the Philips I²C Patent Rights to use these components in an I²C system, provided that the system conforms to the I²C Standard Specification as defined by Philips

I2CDAT Function

I²C Data Register

The I2CDAT SFR is written to by user code to transmit data, or read by user code to read data just received by the I2C interface. Accessing I2CDAT automatically clears any pending I2C interrupt and the I2CI bit in the I2CCON SFR. User code should only access I2CDAT once per interrupt cycle.

SFR Address	0x9A
Power-On Default value	0x00
Bit Addressable	No.

SPI SERIAL INTERFACE

The ADuC845 integrates a complete hardware Serial Peripheral Interface (SPI) interface on-chip. SPI is an industry-standard synchronous serial interface that allows eight bits of data to be synchronously transmitted and received simultaneously, i.e., full duplex. It should be noted that the SPI pins are multiplexed with Port 2 pins (P2.0, P2.1, P2.2 & P2.3). The pins have SPI functionality only if SPE is SET. Otherwise, with SPE cleared standard Port 2 functionality is maintained. SPI can be configured for master or slave operation and typically consists of four pins, namely:

SCLOCK (Serial Clock I/O Pin), Pin 28 (MQFP package), Pin 30 (CSP package)

The master clock (SCLOCK) is used to synchronize the data being transmitted and received through the MOSI and MISO data lines.

A single data bit is transmitted and received in each SCLOCK period. Therefore, a byte is transmitted/received after eight SCLOCK periods. The SCLOCK pin is configured as an output in master mode and as an input in Slave mode. In master mode the bit-rate, polarity, and phase of the clock are controlled by the CPOL, CPHA, SPR0, and SPR1 bits in the SPICON SFR (see Table XV). In Slave mode the SPICON register will have to be configured with the phase and polarity (CPHA and CPOL) as the master as for both Master and Slave mode the data is transmitted on one edge of the SCLOCK signal and sampled on the other.

MISO (Master In, Slave Out Pin), Pin 30 (MQFP package), Pin 32 (CSP package)

The MISO (master in slave out) pin is configured as an input line in Master mode and an output line in Slave mode. The MISO line on the master (data in) should be connected to the MISO line in the slave device (data out). The data is transferred as byte-wide (8-bit) serial data, MSB first.

MOSI (Master Out, Slave In Pin), Pin 29 (MQFP package), Pin31 (CSP package)

The MOSI (master out slave in) pin is configured as an output line in Master mode and an input line in Slave mode. The MOSI line on the master (data out) should be connected to the MOSI line in the slave device (data in). The data is transferred as byte-wide (8-bit) serial data, MSB first.

SS (Slave Select Input Pin), Pin 31 (MQFP package), Pin 33 (CSP package)

The Slave Select (SS) input pin is only used when the ADuC834 is configured in SPI Slave mode. This line is active low. Data is only received or transmitted in Slave mode when the SS pin is low, allowing the ADuC845 to be used in single master, multislave SPI configurations. If CPHA = 1, the SS input may be permanently pulled low. With CPHA = 0, the SS input must be driven low before the first bit in a byte wide transmission or reception and return high again after the last bit in that byte wide transmission or reception. In SPI Slave mode, the logic level on the external SS pin (Pin 13), can be read via the SPR0 bit in the SPICON SFR.

The following SFR registers are used to control the SPI interface.

Table XVI. SPICON SFR Bit Designations

Bit	Name	Description															
7	ISPI	SPI Interrupt bit Set by MicroConverter at the end of each SPI transfer Cleared directly by user code or indirectly by reading the SPIDAT SFR															
6	WCOL	Write Collision Error Bit Set by MicroConverter if SPIDAT is written to while an SPI transfer is in progress Cleared by user code															
5	SPE	SPI Interface Enable Bit Set by user code to enable SPI functionality Cleared by user code to enable standard Port2 functionality															
4	SPIM	SPI Master/Slave Mode Select Bit Set by user code to enable Master mode operation (SCLOCK is an output) Cleared by user code to enable Slave mode operation (SCLOCK is an input)															
3	CPOL ¹	Clock Polarity Bit Set by user code to enable SCLOCK idle High Cleared by user code to enable SCLOCK idle low															
2	CPHA ¹	Clock Phase Select Bit Set by user code if leading SCLOCK edge is to transmit data Cleared by user code if trailing SCLOCK edge is to transmit data.															
1	SPR1	SPI Bit-Rate Bits <table style="display: inline-table; vertical-align: top;"> <thead> <tr> <th>SPR1</th> <th>SPR0</th> <th>Selected Bit Rate</th> </tr> </thead> <tbody> <tr> <td>0</td> <td>0</td> <td>$f_{core}/2$</td> </tr> <tr> <td>0</td> <td>1</td> <td>$f_{core}/4$</td> </tr> <tr> <td>1</td> <td>0</td> <td>$f_{core}/8$</td> </tr> <tr> <td>1</td> <td>1</td> <td>$f_{core}/16$</td> </tr> </tbody> </table>	SPR1	SPR0	Selected Bit Rate	0	0	$f_{core}/2$	0	1	$f_{core}/4$	1	0	$f_{core}/8$	1	1	$f_{core}/16$
SPR1	SPR0		Selected Bit Rate														
0	0		$f_{core}/2$														
0	1		$f_{core}/4$														
1	0		$f_{core}/8$														
1	1	$f_{core}/16$															
0	SPR0																

1. The CPOL and CPHA bits should both contain the same values for master and slave devices.

Note: Both SPI & I²C utilize the same ISR (Vector address 0x3B), therefore when using both SPI & I²C simultaneously it will be necessary to check the interfaces following an interrupt to determine which one caused the interrupt.

OUTLINE DIMENSIONS

52 LEAD METRIC QUAD FLAT PACK (MQFP) (S-52)

Dimensions shown in millimeters

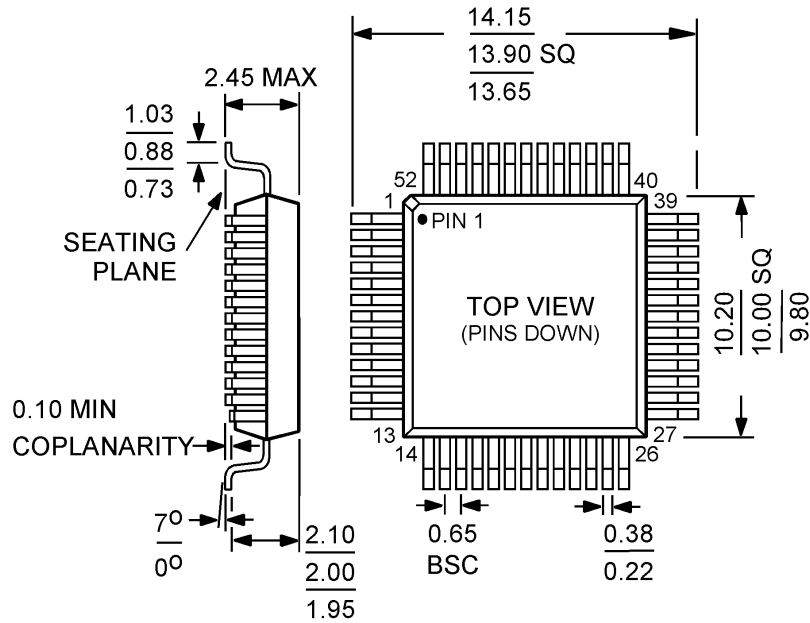

COMPLIANT TO JEDEC STANDARD MO-022-AC-1

56-Lead Frame Chip Scale Package [LFCSP] 8x8 mm Body (CP-56)

Dimensions shown in millimeters

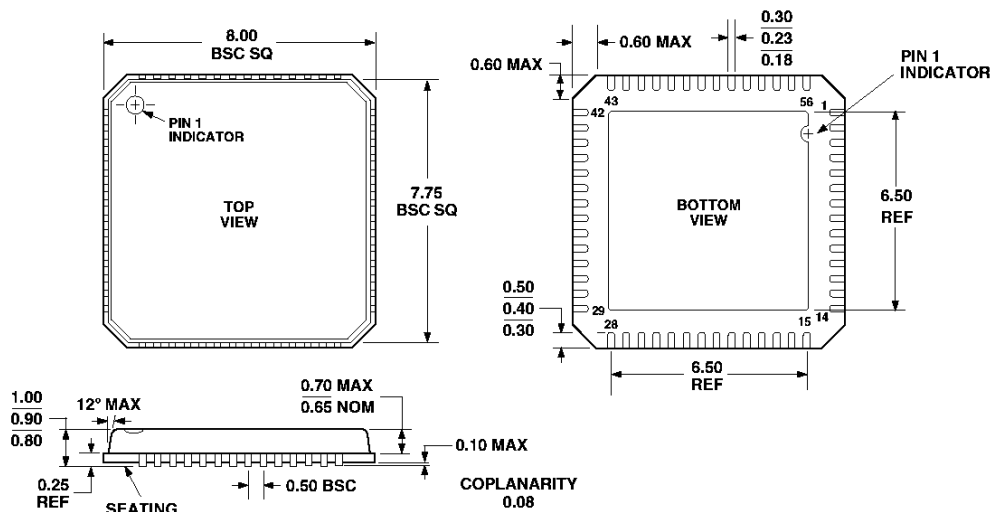

COMPLIANT TO JEDEC STANDARDS MO-220-VLLD-2