



Integrated Device Technology, Inc.

CMOS SyncBiFIFO™

256 x 36 x 2, 512 x 36 x 2,
1024 x 36 x 2

IDT723622
IDT723632
IDT723642

FEATURES:

- Free-running CLKA and CLKB may be asynchronous or coincident (simultaneous reading and writing of data on a single clock edge is permitted)
- Two independent clocked FIFOs buffering data in opposite directions
- Memory storage capacity:
 - IDT723622–256 x 36 x 2
 - IDT723632–512 x 36 x 2
 - IDT723642–1024 x 36 x 2
- Mailbox bypass register for each FIFO
- Programmable Almost-Full and Almost-Empty flags
- Microprocessor Interface Control Logic
- IRA, ORA, AEA, and AFA flags synchronized by CLKA
- IRB, ORB, AEB, and AFB flags synchronized by CLKB
- Supports clock frequencies up to 67MHz

- Fast access times of 11ns
- Available in 132-pin Plastic Quad Flatpack (PQF) or space-saving 120-pin Thin Quad Flatpack (PF)
- Low-power 0.8-Micron Advanced CMOS technology
- Industrial temperature range (-40°C to +85°C) is available, tested to military electrical specifications

DESCRIPTION:

The IDT723622/723632/723642 is a monolithic, high-speed, low-power, CMOS Bidirectional SyncFIFO (clocked) memory which supports clock frequencies up to 67MHz and have read access times as fast as 11ns. Two independent 256/512/1024x36 dual-port SRAM FIFOs on board each chip buffer data in opposite directions. Each FIFO has flags to indicate empty and full conditions and two programmable flags (almost

FUNCTIONAL BLOCK DIAGRAM

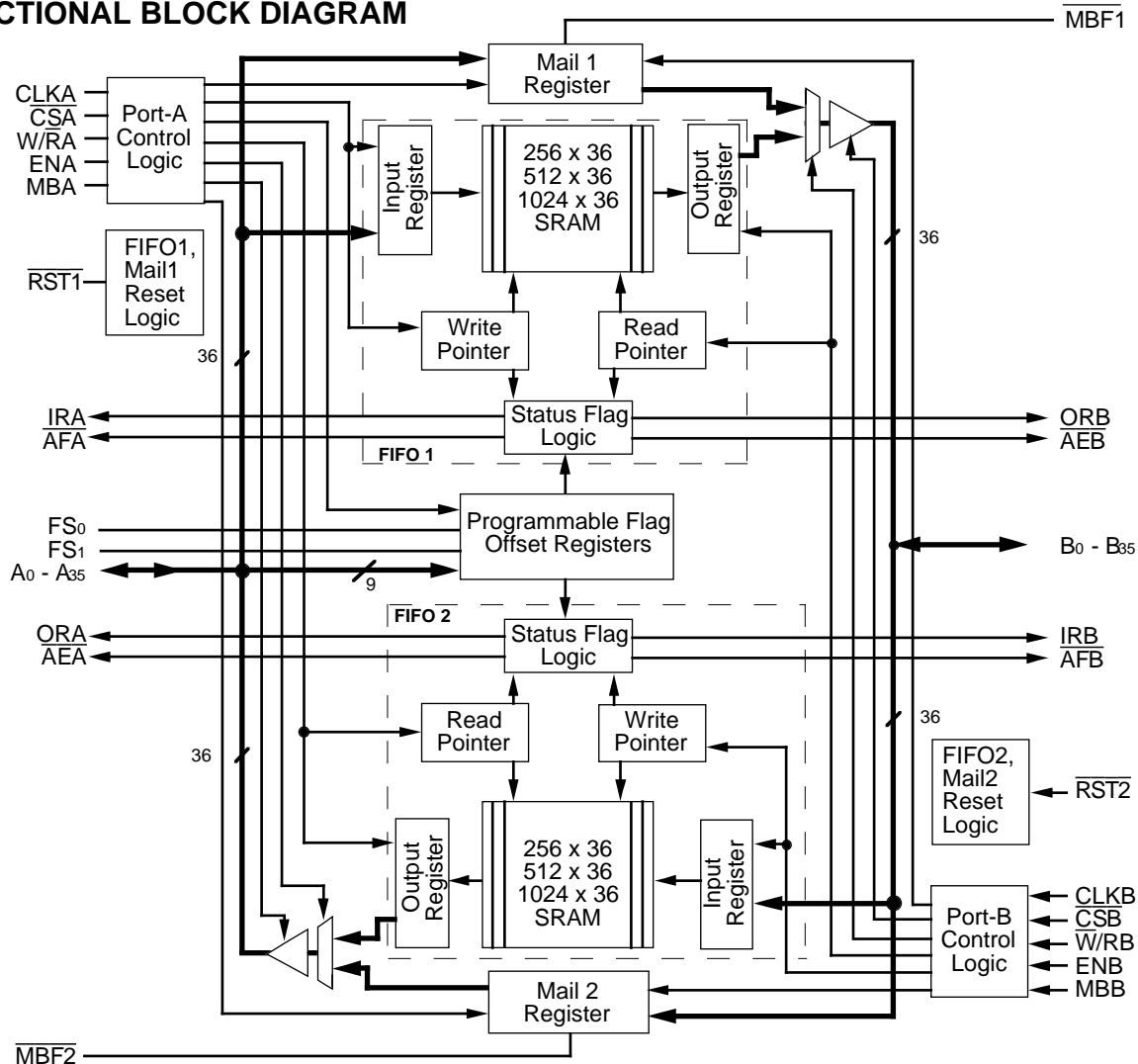

3022 drw 01

SyncFIFO is a trademark and the IDT logo is a registered trademark of Integrated Device Technology, Inc.

COMMERCIAL TEMPERATURE RANGE

DECEMBER 1996

DESCRIPTION (CONTINUED)

Full and almost Empty) to indicate when a selected number of words is stored in memory. Communication between each port may bypass the FIFOs via two 36-bit mailbox registers. Each mailbox register has a flag to signal when new mail has been stored. Two or more devices may be used in parallel to create wider data paths.

The IDT723622/723632/723642 is a synchronous (clocked) FIFO, meaning each port employs a synchronous interface. All data transfers through a port are gated to the LOW-to-HIGH transition of a port clock by enable signals. The clocks for each port are independent of one another and can be

asynchronous or coincident. The enables for each port are arranged to provide a simple bidirectional interface between microprocessors and/or buses with synchronous control.

The Input Ready (IRA, IRB) and Almost-Full (AFA, AFB) flags of a FIFO are two-stage synchronized to the port clock that writes data into its array. The Output Ready (ORA, ORB) and Almost-Empty (AEA, AEB) flags of a FIFO are two-stage synchronized to the port clock that reads data from its array. Offset values for the Almost-Full and Almost-Empty flags of both FIFOs can be programmed from Port A.

The IDT723622/723632/723642 is characterized for operation from 0°C to 70°C.

PIN CONFIGURATION

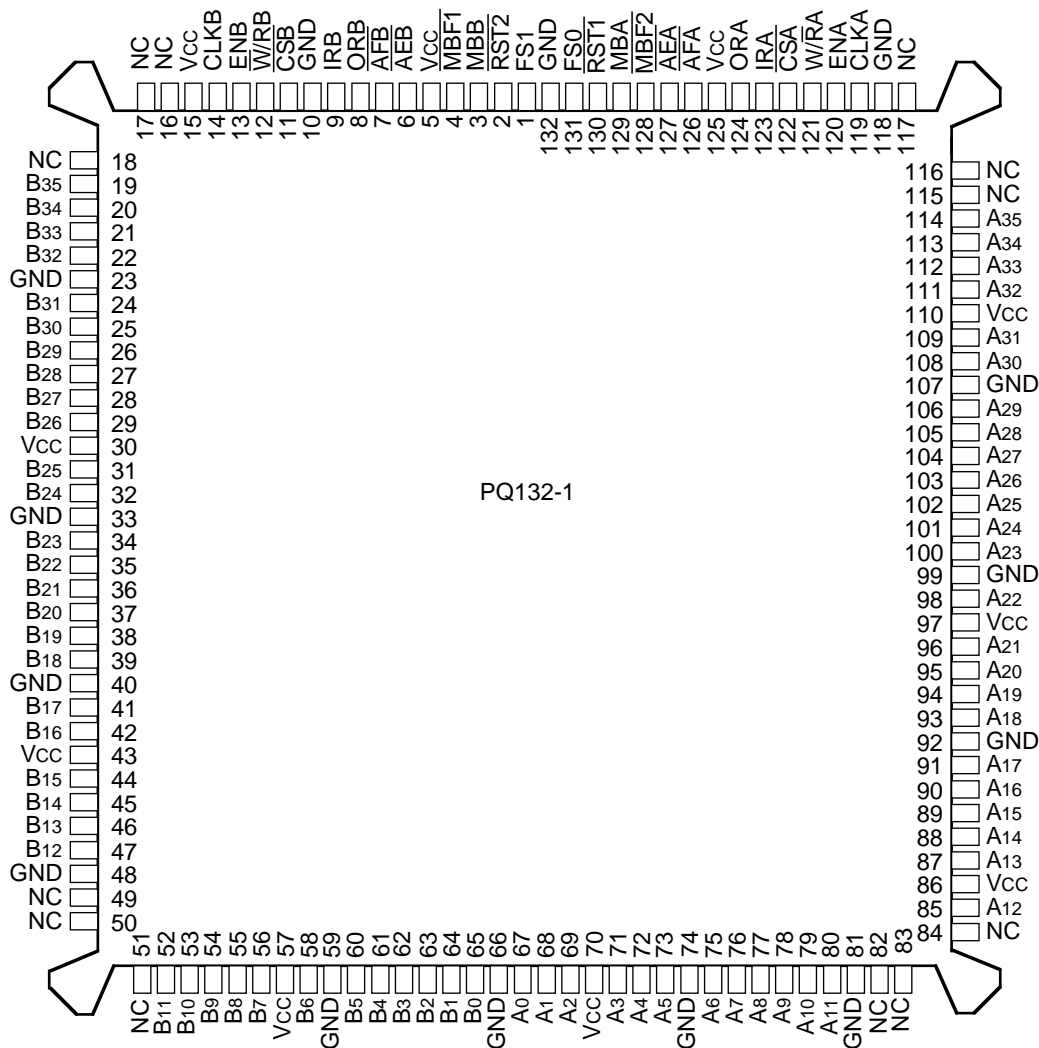

3022 drw 02

PQF Package
TOP VIEW

NOTES:

1. NC – no internal connection
2. Uses Yamaichi socket IC51-1324-828

PIN CONFIGURATION

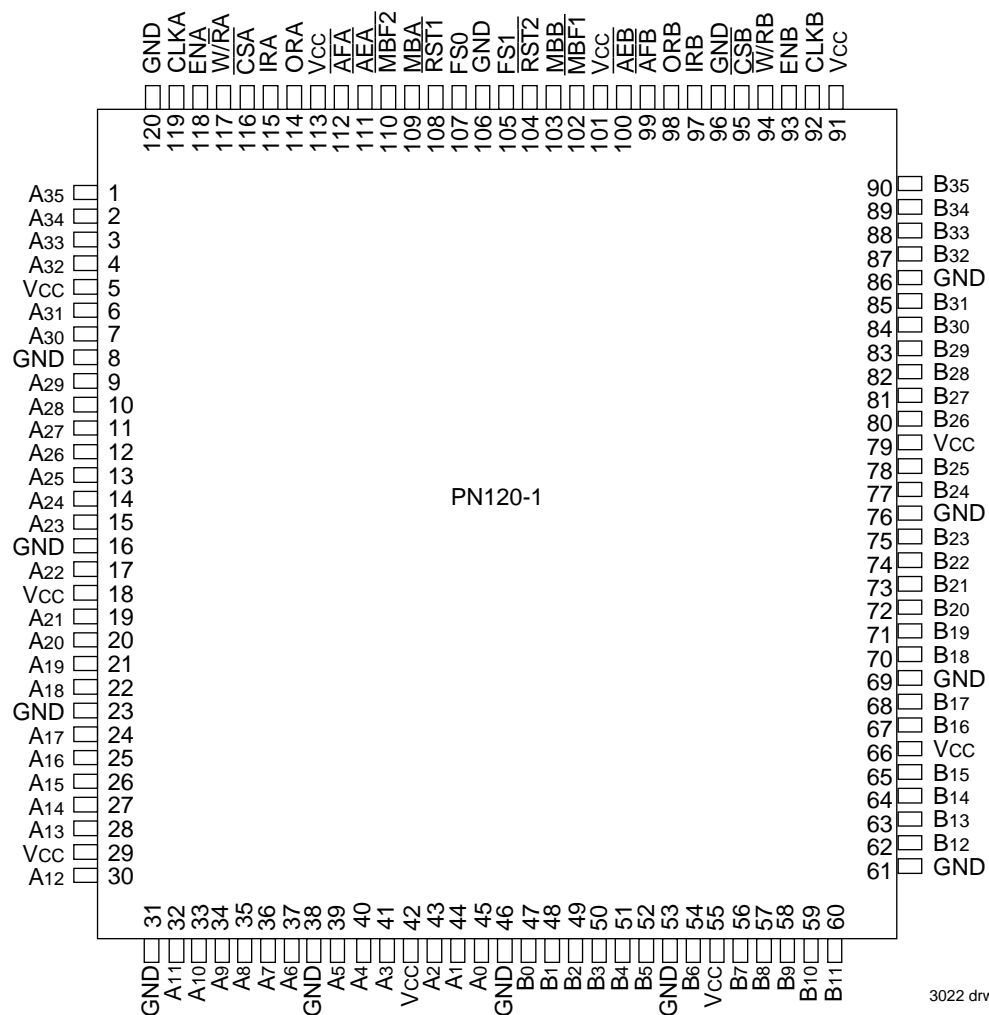

TQFP
TOP VIEW

PIN DESCRIPTIONS

Symbol	Name	I/O	Description
A0-A35	Port-A Data	I/O	36-bit bidirectional data port for side A.
\overline{AEA}	Port-A Almost-Empty Flag	O (Port A)	Programmable almost-empty flag synchronized to CLKA. It is LOW when the number of words in FIF02 is less than or equal to the value in the almost-empty A offset register, X2.
\overline{AEB}	Port-B Almost-Empty Flag	O (Port B)	Programmable almost-empty flag synchronized to CLKB. It is LOW when the number of words in FIF01 is less than or equal to the value in the almost-empty B offset register, X1.
\overline{AFA}	Port-A Almost-Full Flag	O (Port A)	Programmable almost-full flag synchronized to CLKA. It is LOW when the number of empty locations in FIF01 is less than or equal to the value in the almost-full A offset register, Y1.
\overline{AFB}	Port-B Almost-Full Flag	O (Port B)	Programmable almost-full flag synchronized to CLKB. It is LOW when the number of empty locations in FIF02 is less than or equal to the value in the almost-full B offset register, Y2.
B0 - B35	Port-B Data	I/O	36-bit bidirectional data port for side B.
CLKA	Port-A Clock	I	CLKA is a continuous clock that synchronizes all data transfers through port A and can be asynchronous or coincident to CLKB. IRA, ORA, \overline{AFA} , and \overline{AEA} are all synchronized to the LOW-to-HIGH transition of CLKA.
CLKB	Port-B Clock	I	CLKB is a continuous clock that synchronizes all data transfers through port B and can be asynchronous or coincident to CLKA. IRB, ORB, \overline{AFB} , and \overline{AEB} are synchronized to the LOW-to-HIGH transition of CLKB.
\overline{CSA}	Port-A Chip Select	I	\overline{CSA} must be LOW to enable a LOW-to-HIGH transition of CLKA to read or write on port A. The AO-A35 outputs are in the high-impedance state when \overline{CSA} is HIGH.
\overline{CSB}	Port-B Chip Select	I	\overline{CSB} must be LOW to enable a LOW-to-HIGH transition of CLKB to read or write data on port B. The BO- B35 outputs are in the high-impedance state when \overline{CSB} is HIGH.
ENA	Port-A Enable	I	ENA must be HIGH to enable a LOW-to-HIGH transition of CLKA to read or write data on port A.
ENB	Port-B Enable	I	ENB must be HIGH to enable a LOW-to-HIGH transition of CLKB to read or write data on port B.
FS1, FS0	Flag Offset Selects	I	The LOW-to-HIGH transition of a FIFO's reset input latches the values of FSO and FS1. If either FSO or FS1 is HIGH when a reset input goes HIGH, one of the three preset values is selected as the offset for the FIFOs almost-full and almost-empty flags. If both FIFOs are reset simultaneously and both FSO and FS1 are LOW when RST1 and RST2 go HIGH, the first four writes to FIFO1 almost empty offsets for both FIFOs.
IRA	Input-Ready Flag	O (Port A)	IRA is synchronized to the LOW-to-HIGH transition of CLKA. When IRA is LOW, FIFO1 is full and writes to its array are disabled. IRA is set LOW when FIFO1 is reset and is set HIGH on the second LOW-to-HIGH transition of CLKA after reset.
IRB	Input-Ready Flag	O (Port B)	IRB is synchronized to the LOW-to-HIGH transition of CLKB. When IRB is LOW, FIFO2 is full and writes to its array are disabled. IRB is set LOW when FIFO2 is reset and is set HIGH on the second LOW-to-HIGH transition of CLKB after reset.
MBA	Port-A Mailbox Select	I	A HIGH level on MBA chooses a mailbox register for a port-A read or write operation. When the AO-A35 outputs are active, a HIGH level on MBA selects data from the mail2 register for output and a LOW level selects FIF02 output-register data for output.

PIN DESCRIPTIONS (CONT.)

Symbol	Name	I/O	Description
MBB	Port-B Mailbox Select	I	A HIGH level on MBB chooses a mailbox register for a port-B read or write operation. When the B0-B35 outputs are active, a HIGH level on MBB selects data from the mail1 register or output and a LOW level selects FIFO1 output-register data for output.
$\overline{\text{MBF1}}$	Mail1 Register Flag	O	$\overline{\text{MBF1}}$ is set LOW by a LOW-to-HIGH transition of CLKA that writes data to the mail1 register. Writes to the mail1 register are inhibited while $\overline{\text{MBF1}}$ is LOW. $\overline{\text{MBF1}}$ is set HIGH by a LOW-to-HIGH transition of CLKB when a port-B read is selected and MBB is HIGH. $\overline{\text{MBF1}}$ is set HIGH when FIFO1 is reset.
$\overline{\text{MBF2}}$	Mail2 Register Flag	O	$\overline{\text{MBF2}}$ is set LOW by a LOW-to-HIGH transition of CLKB that writes data to the mail2 register. Writes to the mail2 register are inhibited while $\overline{\text{MBF2}}$ is LOW. $\overline{\text{MBF2}}$ is set HIGH by a LOW-to-HIGH transition of CLKA when a port-A read is selected and MBA is HIGH. $\overline{\text{MBF2}}$ is also set HIGH when FIFO2 is reset.
ORA	Output-Ready Flag	O (Port A)	ORA is synchronized to the LOW-to-HIGH transition of CLKA. When ORA is LOW, FIFO2 is empty and reads from its memory are disabled. Ready data is present on the output register of FIFO2 when ORA is HIGH. ORA is forced LOW when FIFO2 is reset and goes HIGH on the third LOW-to-HIGH transition of CLKA after a word is loaded to empty memory.
ORB	Output-Ready Flag	O (Port B)	ORB is synchronized to the LOW-to-HIGH transition of CLKB. When ORB is LOW, FIFO1 is empty and reads from its memory are disabled. Ready data is present on the output register of FIFO1 when ORB is HIGH. ORB is forced LOW when FIFO1 is reset and goes HIGH on the third LOW-to-HIGH transition of CLKB after a word is loaded to empty memory.
$\overline{\text{RST1}}$	FIFO1 Reset	I	To reset FIFO1, four LOW-to-HIGH transitions of CLKA and four LOW-to-HIGH transitions of CLKB must occur while $\overline{\text{RST1}}$ is LOW. The LOW-to-HIGH transition of $\overline{\text{RST1}}$ latches the status of FSO and FS1 for $\overline{\text{AFA}}$ and $\overline{\text{AEB}}$ offset selection. FIFO1 must be reset upon power up before data is written to its RAM.
$\overline{\text{RST2}}$	FIFO2 Reset	I	To reset FIFO2, four LOW-to-HIGH transitions of CLKA and four LOW-to-HIGH transitions of CLKB must occur while $\overline{\text{RST2}}$ is LOW. The LOW-to-HIGH transition of $\overline{\text{RST2}}$ latches the status of FSO and FS1 for $\overline{\text{AFB}}$ and $\overline{\text{AEA}}$ offset selection. FIFO2 must be reset upon power up before data is written to its RAM.
$\overline{\text{W/RA}}$	Port-A Write/Read Select	I	A HIGH selects a write operation and a LOW selects a read operation on port A for a LOW-to-HIGH transition of CLKA. The AO-A35 outputs are in the HIGH impedance state when $\overline{\text{W/RA}}$ is HIGH.
$\overline{\text{W/RB}}$	Port-B Write/Read Select	I	A LOW selects a write operation and a HIGH selects a read operation on port B for a LOW-to-HIGH transition of CLKB. The BO-B35 outputs are in the HIGH impedance state when $\overline{\text{W/RB}}$ is LOW.

ABSOLUTE MAXIMUM RATINGS OVER OPERATING FREE-AIR TEMPERATURE RANGE (UNLESS OTHERWISE NOTED)⁽¹⁾

Symbol	Rating	Commercial	Unit
VCC	Supply Voltage Range	-0.5 to 7	V
VI ⁽²⁾	Input Voltage Range	-0.5 to VCC+0.5	V
VO ⁽²⁾	Output Voltage Range	-0.5 to VCC+0.5	V
I _{IK}	Input Clamp Current (VI < 0 or VI > VCC)	±20	mA
I _{OK}	Output Clamp Current (VO = < 0 or VO > VCC)	±50	mA
I _{OUT}	Continuous Output Current (VO = 0 to VCC)	±50	mA
I _{CC}	Continuous Current Through VCC or GND	±400	mA
TA	Operating Free Air Temperature Range	0 to 70	°C
T _{STG}	Storage Temperature Range	-65 to 150	°C

NOTES:

- Stresses beyond those listed under "Absolute Maximum Ratings" may cause permanent damage to the device. These are stress ratings only and functional operation of the device at these or any other conditions beyond those indicated under "recommended operating conditions" is not implied. Exposure to absolute-maximum-rated conditions for extended periods may affect device reliability.
- The input and output voltage ratings may be exceeded provided the input and output current ratings are observed.

RECOMMENDED OPERATING CONDITIONS

Symbol	Parameter	Min.	Max.	Unit
VCC	Supply Voltage	4.5	5.5	V
V _{IH}	High-Level Input Voltage	2		V
V _{IL}	Low-Level Input Voltage		0.8	V
I _{OH}	High-Level Output Current		-4	mA
I _{OL}	Low-Level Output Current		8	mA
TA	Operating Free-Air Temperature	0	70	°C

ELECTRICAL CHARACTERISTICS OVER RECOMMENDED OPERATING FREE-AIR TEMPERATURE RANGE (UNLESS OTHERWISE NOTED)

Parameter	Test Conditions		IDT723622 IDT723632 IDT723642 Commerical tA = 15, 20, 30 ns			Unit	
			Min.	Typ. ⁽¹⁾	Max.		
VOH	VCC = 4.5V,	I _{OH} = -4 mA	2.4			V	
VOL	VCC = 4.5 V,	I _{OL} = 8 mA			0.5	V	
ILI	VCC = 5.5 V,	V _I = VCC or 0			±5	μA	
ILO	VCC = 5.5 V,	V _O = VCC or 0			±5	μA	
ICC	VCC = 5.5 V,	V _I = VCC -0.2 V or 0			400	μA	
ΔI _{CC} ⁽²⁾	VCC = 5.5 V,	One Input at 3.4 V, Other Inputs at VCC or GND	$\overline{CSA} = VIH$	A0-A35	0		mA
			$\overline{CSB} = VIH$	B0-B35	0		
			$\overline{CSA} = VIL$	A0-A35		1	
			$\overline{CSB} = VIL$	B0-35		1	
			All Other Inputs				
C _{IN}	V _I = 0,	f = 1 MHz			4	pF	
C _{OUT}	V _O = 0,	f = 1 MHz			8	pF	

NOTES:

1. All typical values are at VCC = 5V, TA = 25°C.
2. This is the supply current when each input is at least one of the specified TTL voltage levels rather than 0V or VCC.

TIMING REQUIREMENTS OVER RECOMMENDED RANGES OF SUPPLY VOLTAGE AND OPERATING FREE-AIR TEMPERATURE

Symbol	Parameter	723622-15		723622-20		723622-30		Unit
		723632-15		723632-20		723632-30		
		723642-15		723642-20		723642-30		
		Min.	Max.	Min.	Max.	Min.	Max.	
fs	Clock Frequency, CLKA or CLKB		66.7		50		33.4	MHz
tCLK	Clock Cycle Time, CLKA or CLKB	15		20		30		ns
tCLKH	Pulse Duration, CLKA or CLKB HIGH	6		8		10		ns
tCLKL	Pulse Duration, CLKA and CLKB LOW	6		8		10		ns
tDS	Setup Time, A0-A35 before CLKA↑ and B0-B35 before CLKB↑	4		5		6		ns
tENS	Setup Time, \overline{CSA} , $\overline{W/RA}$, ENA, and MBA before CLKA↑; \overline{CSB} , $\overline{W/RB}$, ENB, and MBB before CLKB↑	4.5		5		6		ns
tRSTS	Setup Time, $\overline{RST1}$ or $\overline{RST2}$ LOW before CLKA↑ or CLKB↑ ⁽¹⁾	5		6		7		ns
tFSS	Setup Time, FS0 and FS1 before $\overline{RST1}$ and $\overline{RST2}$ HIGH	7.5		8.5		9.5		ns
tDH	Hold Time, A0-A35 after CLKA↑ and B0-B35 after CLKB↑	1		1		1		ns
tENH	Hold Time, \overline{CSA} , $\overline{W/RA}$, ENA, and MBA after CLKA↑; \overline{CSB} , $\overline{W/RB}$, ENB, and MBB after CLKB↑	1		1		1		ns
tRSTH	Hold Time, $\overline{RST1}$ or $\overline{RST2}$ LOW after CLKA↑ or CLKB↑ ⁽¹⁾	4		4		5		ns
tFSH	Hold Time, FS0 and FS1 after $\overline{RST1}$ and $\overline{RST2}$ HIGH	2		3		3		ns
tSKEW1 ⁽²⁾	Skew Time, between CLKA↑ and CLKB↑ for ORA, ORB, IRA, and IRB	7.5		9		11		ns
tSKEW2 ⁽²⁾	Skew Time, between CLKA↑ and CLKB↑ for \overline{AEA} , \overline{AEB} , \overline{AFA} , and \overline{AFB}	12		16		20		ns

NOTES:

1. Requirement to count the clock edge as one of at least four needed to reset a FIFO.
2. Skew time is not a timing constraint for proper device operation and is only included to illustrate the timing relationship between CLKA cycle and CLKB cycle.

SWITCHING CHARACTERISTICS OVER RECOMMENDED RANGES OF SUPPLY VOLTAGE AND OPERATING FREE-AIR TEMPERATURE, CL = 30 pF

Symbol	Parameter	723622L15		723622L20		723622L30		Unit
		723632L15		723632L20		723632L30		
		723642L15		723642L20		723642L30		
		Min.	Max.	Min.	Max.	Min.	Max.	
tA	Access Time, CLKA↑ to A0-A35 and CLKB↑ to B0-B35	3	11	3	13	3	15	ns
tPIR	Propagation Delay Time, CLKA↑ to IRA and CLKB↑ to IRB	2	8	2	10	2	12	ns
tPOR	Propagation Delay Time, CLKA↑ to ORA and CLKB↑ to ORB	1	8	1	10	1	12	ns
tPAE	Propagation Delay Time, CLKA↑ to $\overline{A}EA$ and CLKB↑ to $\overline{A}EB$	1	8	1	10	1	12	ns
tPAF	Propagation Delay Time, CLKA↑ to $\overline{A}FA$ and and CLKB↑ to $\overline{A}FB$	1	8	1	10	1	12	ns
tPMF	Propagation Delay Time, CLKA↑ to $\overline{M}BF1$ LOW or $\overline{M}BF2$ HIGH and CLKB↑ to $\overline{M}BF2$ LOW or $\overline{M}BF1$ HIGH	0	8	0	10	0	12	ns
tPMR	Propagation Delay Time, CLKA↑ to B0-B35 ⁽¹⁾ and CLKB↑ to A0-A35 ⁽²⁾	3	13.5	3	15	3	17	ns
tMDV	Propagation Delay Time, MBA to A0-A35 valid and MBB to B0-B35 Valid	3	11	3	13	3	15	ns
tPRF	Propagation Delay Time, $\overline{R}ST1$ LOW to $\overline{A}EB$ LOW, $\overline{A}FA$ HIGH, and $\overline{M}BF1$ HIGH, and $\overline{R}ST2$ LOW to $\overline{A}EA$ LOW, $\overline{A}FB$ HIGH, and $\overline{M}BF2$ HIGH	1	15	1	20	1	30	ns
tEN	Enable Time, $\overline{C}SA$ and $\overline{W}/\overline{R}A$ LOW to A0-A35 Active and $\overline{C}SB$ LOW and $\overline{W}/\overline{R}B$ HIGH to B0-B35 Active	2	12	2	13	2	14	ns
tDIS	Disable Time, $\overline{C}SA$ or $\overline{W}/\overline{R}A$ HIGH to A0-A35 at high impedance and $\overline{C}SB$ HIGH or $\overline{W}/\overline{R}B$ LOW to B0-B35 at HIGH impedance	1	8	1	10	1	11	ns

NOTES:

1. Writing data to the mail1 register when the B0-B35 outputs are active and MBB is HIGH.
2. Writing data to the mail2 register when the A0-A35 outputs are active and MBA is HIGH.

SIGNAL DESCRIPTION

RESET

The FIFO memories of the IDT723622/723632/723642 are reset separately by taking their reset ($\overline{RST1}$, $\overline{RST2}$) inputs LOW for at least four port-A clock (CLKA) and four port-B clock (CLKB) LOW-to-HIGH transitions. The reset inputs can switch asynchronously to the clocks. A FIFO reset initializes the internal read and write pointers and forces the input-ready flag (IRA, IRB) LOW, the output-ready flag (ORA, ORB) LOW, the almost-empty flag (\overline{AEA} , \overline{AEB}) LOW, and the almost-full flag (\overline{AFA} , \overline{AFB}) HIGH. Resetting a FIFO also forces the mailbox flag ($\overline{MBF1}$, $\overline{MBF2}$) of the parallel mailbox register HIGH. After a FIFO is reset, its input-ready flag is set HIGH after two clock cycles to begin normal operation. A FIFO must be reset after power up before data is written to its memory.

A LOW-to-HIGH transition on a FIFO reset ($\overline{RST1}$, $\overline{RST2}$) input latches the value of the flag-select (FS0, FS1) inputs for choosing the almost-full and almost-empty offset programming method (see *almost-empty and almost-full flag offset programming* below).

ALMOST-EMPTY FLAG AND ALMOST-FULL FLAG OFFSET PROGRAMMING

Four registers in the IDT723622/723632/723642 are used to hold the offset values for the almost-empty and almost-full flags. The port-B almost-empty flag (\overline{AEB}) offset register is labeled X1 and the port-A almost-empty flag (\overline{AEA}) offset register is labeled X2. The port-A almost-full flag (\overline{AFA}) offset register is labeled Y1 and the port-B almost-full flag (\overline{AFB}) offset register is labeled Y2. The index of each register name corresponds to its FIFO number. The offset registers can be loaded with preset values during the reset of a FIFO or they can be programmed from port A (see Table 1).

To load a FIFO almost-empty flag and almost-full flag offset registers with one of the three preset values listed in Table1, at least one of the flag-select inputs must be HIGH

during the LOW-to-HIGH transition of its reset input. For example, to load the preset value of 64 into X1 and Y1, FS0 and FS1 must be HIGH when FIFO1 reset ($\overline{RST1}$) returns HIGH. Flag-offset registers associated with FIFO2 are loaded with one of the preset values in the same way with FIFO2 reset ($\overline{RST2}$). When using one of the preset values for the flag offsets, the FIFOs can be reset simultaneously or at different times.

To program the X1, X2, Y1, and Y2 registers from port A, both FIFOs should be reset simultaneously with FS0 and FS1 LOW during the LOW-to-HIGH transition of the reset inputs. After this reset is complete, the first four writes to FIFO1 do not store data in RAM but load the offset registers in the order Y1, X1, Y2, X2. The port A data inputs used by the offset registers are (A7-A0), (A8-A0), or (A9-A0) for the IDT723622, IDT723632, or IDT723642, respectively. The highest numbered input is used as the most significant bit of the binary number in each case. Valid programming values for the registers ranges from 1 to 252 for the IDT723622; 1 to 508 for the IDT723632; and 1 to 1020 for the IDT723642. After all the offset registers are programmed from port A, the port-B input-ready flag (IRB) is set HIGH, and both FIFOs begin normal operation.

FIFO WRITE/READ OPERATION

The state of the port-A data (A0-A35) outputs is controlled by port-A chip select (\overline{CSA}) and port-A write/read select ($\overline{W/RA}$). The A0-A35 outputs are in the High-impedance state when either \overline{CSA} or $\overline{W/RA}$ is HIGH. The A0-A35 outputs are active when both \overline{CSA} and $\overline{W/RA}$ are LOW.

Data is loaded into FIFO1 from the A0-A35 inputs on a LOW-to-HIGH transition of CLK_A when \overline{CSA} is LOW, $\overline{W/RA}$ is HIGH, ENA is HIGH, MBA is LOW, and IRA is HIGH. Data is read from FIFO2 to the A0-A35 outputs by a LOW-to-HIGH transition of CLK_A when \overline{CSA} is LOW, $\overline{W/RA}$ is LOW, ENA is HIGH, MBA is LOW, and ORA is HIGH (see Table 2). FIFO reads and writes on port A are independent of any concurrent

FS1	FS0	$\overline{RST1}$	$\overline{RST2}$	X1 AND Y1 REGISTERS ⁽¹⁾	X2 AND Y2 REGISTERS ⁽²⁾
H	H	↑	X	64	X
H	H	X	↑	X	64
H	L	↑	X	16	X
H	L	X	↑	X	16
L	H	↑	X	8	X
L	H	X	↑	X	8
L	L	↑	↑	Programmed from port A	Programmed from port A

NOTES:

1. X1 register holds the offset for \overline{AEB} ; Y1 register holds the offset for \overline{AFA} .
2. X2 register holds the offset for \overline{AEA} ; Y2 register holds the offset for \overline{AFB} .

Table 1. Flag Programming

port-B operation.

The port-B control signals are identical to those of port A with the exception that the port-B write/read select ($\overline{W/RB}$) is the inverse of the port-A write/read select ($\overline{W/RA}$). The state of the port-B data (B0-B35) outputs is controlled by the port-B chip select (\overline{CSB}) and port-B write/read select ($\overline{W/RB}$). The B0-B35 outputs are in the high-impedance state when either \overline{CSB} is HIGH or $\overline{W/RB}$ is LOW. The B0-B35 outputs are active when \overline{CSB} is LOW and $\overline{W/RB}$ is HIGH.

Data is loaded into FIFO2 from the B0-B35 inputs on a LOW-to-HIGH transition of CLKB when \overline{CSB} is LOW, $\overline{W/RB}$ is LOW, ENB is HIGH, MBB is LOW, and IRB is HIGH. Data is read from FIFO1 to the B0-B35 outputs by a LOW-to-HIGH transition of CLKB when \overline{CSB} is LOW, $\overline{W/RB}$ is HIGH, ENB is HIGH, MBB is LOW, and ORB is HIGH (see Table 3). FIFO reads and writes on port B are independent of any concurrent port-A operation.

The setup and hold time constraints to the port clocks for the port chip selects and write/read selects are only for enabling write and read operations and are not related to high-impedance control of the data outputs. If a port enable is LOW

during a clock cycle, the port's chip select and write/read select may change states during the setup and hold time window of the cycle.

When a FIFO output-ready flag is LOW, the next data word is sent to the FIFO output register automatically by the LOW-to-HIGH transition of the port clock that sets the output-ready flag HIGH. When the output-ready flag is HIGH, an available data word is clocked to the FIFO output register only when a FIFO read is selected by the port's chip select, write/read select, enable, and mailbox select.

SYNCHRONIZED FIFO FLAGS

Each FIFO is synchronized to its port clock through at least two flip-flop stages. This is done to improve flag-signal reliability by reducing the probability of metastable events when CLKA and CLKB operate asynchronously to one another. \overline{ORA} , \overline{AEA} , \overline{IRA} , and \overline{AFA} are synchronized to CLKA. \overline{ORB} , \overline{AEB} , \overline{IRB} , and \overline{AFB} are synchronized to CLKB. Tables 4 and 5 show the relationship of each port flag to FIFO1 and FIFO2.

\overline{CSA}	$\overline{W/RA}$	ENA	MBA	CLKA	A0-A35 OUTPUTS	PORT FUNCTION
H	X	X	X	X	In high-impedance state	None
L	H	L	X	X	In high-impedance state	None
L	H	H	L	↑	In high-impedance state	FIFO1 write
L	H	H	H	↑	In high-impedance state	Mail1 write
L	L	L	L	X	Active, FIFO2 output register	None
L	L	H	L	↑	Active, FIFO2 output register	FIFO2 read
L	L	L	H	X	Active, mail2 register	None
L	L	H	H	↑	Active, mail2 register	Mail2 read (set $\overline{MBF2}$ HIGH)

Table 2. Port-A Enable Function Table

\overline{CSB}	$\overline{W/RB}$	ENB	MBB	CLKB	B0-B35 OUTPUTS	PORT FUNCTION
H	X	X	X	X	In high-impedance state	None
L	L	L	X	X	In high-impedance state	None
L	L	H	L	↑	In high-impedance state	FIFO2 write
L	L	H	H	↑	In high-impedance state	Mail2 write
L	H	L	L	X	Active, FIFO1 output register	None
L	H	H	L	↑	Active, FIFO1 output register	FIFO1 read
L	H	L	H	X	Active, mail1 register	None
L	H	H	H	↑	Active, mail1 register	Mail1 read (set $\overline{MBF1}$ HIGH)

Table 3. Port-B Enable Function Table

OUTPUT-READY FLAGS (ORA, ORB)

The output-ready flag of a FIFO is synchronized to the port clock that reads data from its array. When the output-ready flag is HIGH, new data is present in the FIFO output register. When the output-ready flag is LOW, the previous data word is present in the FIFO output register and attempted FIFO reads are ignored.

A FIFO read pointer is incremented each time a new word is clocked to its output register. The state machine that controls an output-ready flag monitors a write pointer and read pointer comparator that indicates when the FIFO SRAM status is empty, empty+1, or empty+2. From the time a word is written to a FIFO, it can be shifted to the FIFO output register in a minimum of three cycles of the output-ready flag synchronizing clock. Therefore, an output-ready flag is LOW if a word in memory is the next data to be sent to the FIFO output register and three cycles of the port Clock that reads data from the FIFO have not elapsed since the time the word was written. The output-ready flag of the FIFO remains LOW until the third LOW-to-HIGH transition of the synchronizing clock

occurs, simultaneously forcing the output-ready flag HIGH and shifting the word to the FIFO output register.

A LOW-to-HIGH transition on an output-ready flag synchronizing clock begins the first synchronization cycle of a write if the clock transition occurs at time t_{SKEW1} or greater after the write. Otherwise, the subsequent clock cycle can be the first synchronization cycle (see Figures 7 and 8).

INPUT-READY FLAGS (IRA, IRB)

The input-ready flag of a FIFO is synchronized to the port clock that writes data to its array. When the input-ready flag is HIGH, a memory location is free in the SRAM to receive new data. No memory locations are free when the input-ready flag is LOW and attempted writes to the FIFO are ignored.

Each time a word is written to a FIFO, its write pointer is incremented. The state machine that controls an input-ready flag monitors a write pointer and read pointer comparator that indicates when the FIFO SRAM status is full, full-1, or full-2. From the time a word is read from a FIFO, its previous memory location is ready to be written in a minimum of two cycles of the

Number of Words in FIFO			synchronized to CLKB		Synchronized to CLKA	
IDT723622 ^(1,2)	IDT723632 ^(1,2)	IDT723642 ^(1,2)	ORB	ĀEB	ĀFĀ	IRA
0	0	0	L	L	H	H
1 to X1	1 to X1	1 to X1	H	L	H	H
(X1+1) to [256-(Y1+1)]	(X1+1) to [512-(Y1+1)]	(X1+1) to [1024-(Y1+1)]	H	H	H	H
(256-Y1) to 255	(512-Y1) to 511	(1024-Y1) to 1023	H	H	L	H
256	512	1024	H	H	L	L

Table 4. FIF01 Flag Operation

Notes:

1. X1 is the almost-empty offset for FIF01 used by \overline{AEB} . Y1 is the almost-full offset for FIF01 used by $\overline{AF\overline{A}}$. Both X1 and Y1 are selected during a reset of FIF01 or programmed from port A.
2. When a word loaded to an empty FIFO is shifted to the output register, its previous FIFO memory location is free.

Number of Words in FIFO			synchronized to CLKA		Synchronized to CLKB	
IDT723622 ^(1,2)	IDT723632 ^(1,2)	IDT723642 ^(1,2)	ORA	ĀEA	ĀFB	IRB
0	0	0	L	L	H	H
1 to X2	1 to X2	1 to X2	H	L	H	H
(X2+1) to [256-(Y2+1)]	(X2+1) to [512-(Y2+1)]	(X2+1) to [1024-(Y2+1)]	H	H	H	H
(256-Y2) to 255	(512-Y2) to 511	(1024-Y2) to 1023	H	H	L	H
256	512	1024	H	H	L	L

Table 5. FIF02 Flag Operation

Notes:

1. X2 is the almost-empty offset for FIF02 used by \overline{AEA} . Y2 is the almost-full offset for FIF02 used by $\overline{AF\overline{B}}$. Both X2 and Y2 are selected during a reset of FIF02 or programmed from port A.
2. When a word loaded to an empty FIFO is shifted to the output register, its previous FIFO memory location is free.

input-ready flag synchronizing clock. Therefore, an input-ready flag is LOW if less than two cycles of the input-ready flag synchronizing clock have elapsed since the next memory write location has been read. The second LOW-to-HIGH transition on the input-ready flag synchronizing Clock after the read sets the input-ready flag HIGH.

A LOW-to-HIGH transition on an input-ready flag synchronizing clock begins the first synchronization cycle of a read if the clock transition occurs at time t_{SKEW1} or greater after the read. Otherwise, the subsequent clock cycle can be the first synchronization cycle (see Figures 9 and 10).

ALMOST-EMPTY FLAGS (\overline{AEA} , \overline{AEB})

The almost-empty flag of a FIFO is synchronized to the port clock that reads data from its array. The state machine that controls an almost-empty flag monitors a write pointer and read pointer comparator that indicates when the FIFO SRAM status is almost empty, almost empty+1, or almost empty+2. The almost-empty state is defined by the contents of register X1 for \overline{AEB} and register X2 for \overline{AEA} . These registers are loaded with preset values during a FIFO reset or programmed from port A (see *almost-empty flag and almost-full flag offset programming* above). An almost empty Flag is LOW when its FIFO contains X or less words and is HIGH when its FIFO contains (X+1) or more words. A data word present in the FIFO output register has been read from memory.

Two LOW-to-HIGH transitions of the almost-empty flag synchronizing clock are required after a FIFO write for its almost-empty flag to reflect the new level of fill. Therefore, the almost-full flag of a FIFO containing (X+1) or more words remains LOW if two cycles of its synchronizing clock have not elapsed since the write that filled the memory to the (X+1) level. An almost-empty flag is set HIGH by the second LOW-to-HIGH transition of its synchronizing clock after the FIFO write that fills memory to the (X+1) level. A LOW-to-HIGH transition of an almost-empty flag synchronizing clock begins the first synchronization cycle if it occurs at time t_{SKEW2} or greater after the write that fills the FIFO to (X+1) words. Otherwise, the subsequent synchronizing clock cycle may be the first synchronization cycle. (See Figures 11 and 12).

ALMOST-FULL FLAGS (\overline{AFA} , \overline{AFB})

The almost-full flag of a FIFO is synchronized to the port clock that writes data to its array. The state machine that controls an almost-full flag monitors a write pointer and read pointer comparator that indicates when the FIFO SRAM status is almost full, almost full-1, or almost full-2. The almost-full state is defined by the contents of register Y1 for \overline{AFA} and register Y2 for \overline{AFB} . These registers are loaded with preset values during a FIFO reset or programmed from port A (see

almost-empty flag and almost-full flag offset programming above). An almost-full flag is LOW when the number of words in its FIFO is greater than or equal to (256-Y), (512-Y), or (1024-Y) for the IDT723622, IDT723632, or IDT723642 respectively. An almost-full flag is HIGH when the number of words in its FIFO is less than or equal to [256-(Y+1)], [512-(Y+1)], or [1024-(Y+1)] for the IDT723622, IDT723632, or IDT723642 respectively. Note that a data word present in the FIFO output register has been read from memory.

Two LOW-to-HIGH transitions of the almost-full flag synchronizing clock are required after a FIFO read for its almost-full flag to reflect the new level of fill. Therefore, the almost-full flag of a FIFO containing [256/512/1024-(Y+1)] or less words remains LOW if two cycles of its synchronizing clock have not elapsed since the read that reduced the number of words in memory to [256/512/1024-(Y+1)]. An almost-full flag is set HIGH by the second LOW-to-HIGH transition of its synchronizing clock after the FIFO read that reduces the number of words in memory to [256/512/1024-(Y+1)]. A LOW-to-HIGH transition of an almost-full flag synchronizing clock begins the first synchronization cycle if it occurs at time t_{SKEW2} or greater after the read that reduces the number of words in memory to [256/512/1024-(Y+1)]. Otherwise, the subsequent synchronizing clock cycle may be the first synchronization cycle (see Figures 13 and 14).

MAILBOX REGISTERS

Each FIFO has a 36-bit bypass register to pass command and control information between port A and port B without putting it in queue. The mailbox-select (MBA, MBB) inputs choose between a mail register and a FIFO for a port data transfer operation. A LOW-to-HIGH transition on CLKA writes A0-A35 data to the mail1 register when a port-A write is selected by \overline{CSA} , W/\overline{RA} , and ENA and with MBA HIGH. A LOW-to-HIGH transition on CLKB writes B0-B35 data to the mail2 register when a port-B write is selected by \overline{CSB} , $\overline{W/RB}$, and ENB and with MBB HIGH. Writing data to a mail register sets its corresponding flag ($\overline{MBF1}$ or $\overline{MBF2}$) LOW. Attempted writes to a mail register are ignored while the mail flag is LOW.

When data outputs of a port are active, the data on the bus comes from the FIFO output register when the port mailbox select input is LOW and from the mail register when the port-mailbox select input is HIGH. The mail1 register flag ($\overline{MBF1}$) is set HIGH by a LOW-to-HIGH transition on CLKB when a port-B read is selected by \overline{CSB} , $\overline{W/RB}$, and ENB and with MBB HIGH. The mail2 register flag ($\overline{MBF2}$) is set HIGH by a LOW-to-HIGH transition on CLKA when a port-A read is selected by \overline{CSA} , W/\overline{RA} , and ENA and with MBA HIGH. The data in a mail register remains intact after it is read and changes only when new data is written to the register.

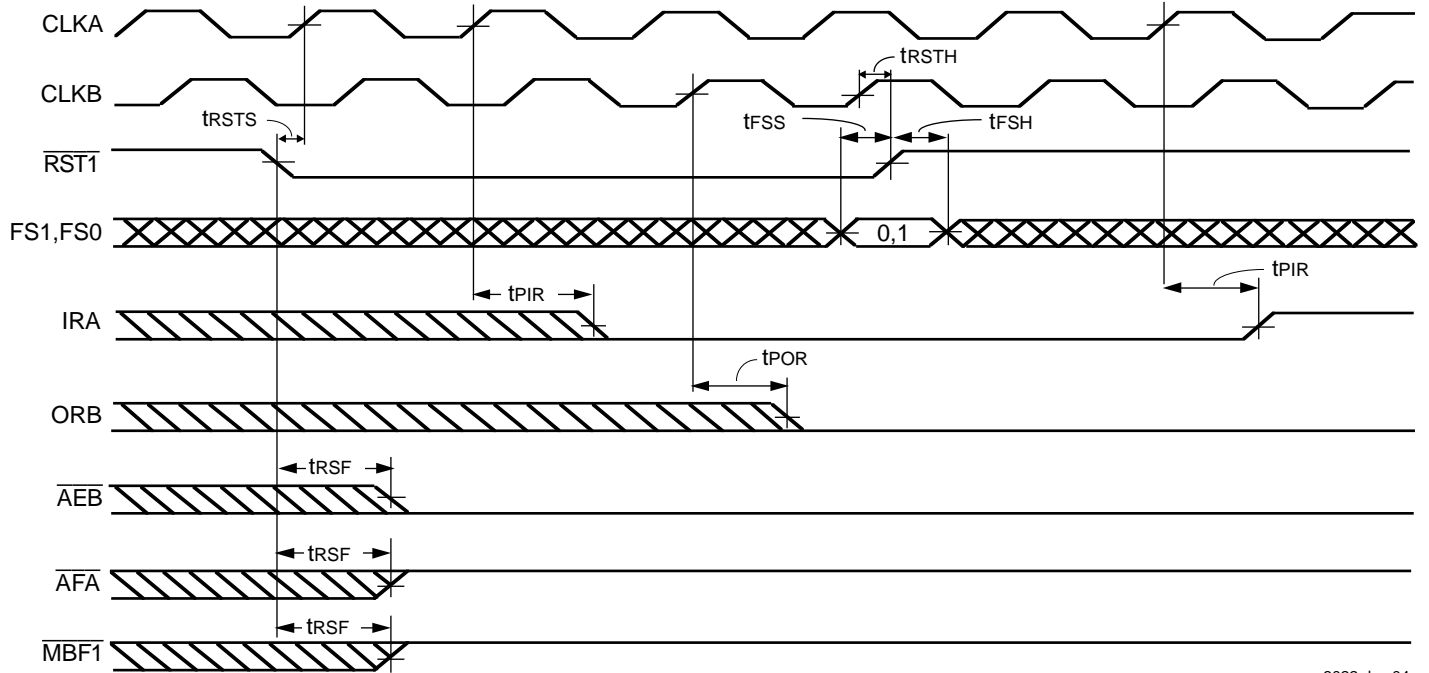

3022 drw 04

Figure 1. FIFO1 Reset Loading X1 and Y1 with a Preset Value of Eight⁽¹⁾.

NOTE:

1. FIFO2 is reset in the same manner to load X2 and Y2 with a preset value.

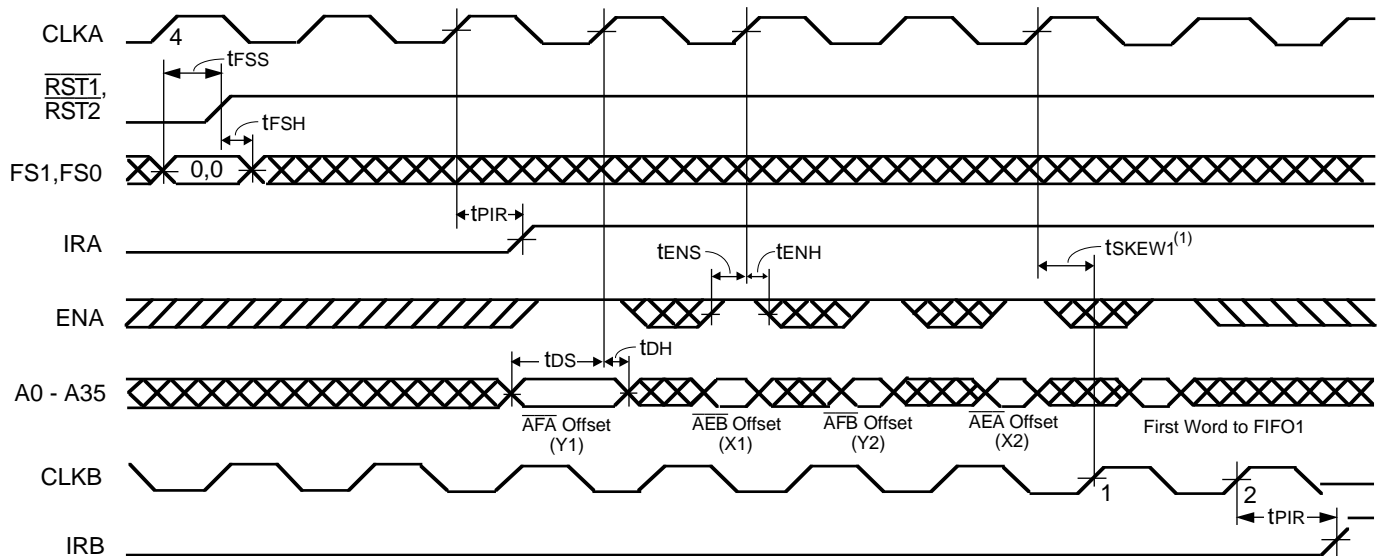

3022 drw 05

NOTES:

1. t_{SKEW1} is the minimum time between the rising CLK_A edge and a rising CLK_B edge for \overline{IRB} to transition HIGH in the next cycle. If the time between the rising edge of CLK_A and rising edge of CLK_B is less than t_{SKEW1} , then \overline{IRB} may transition HIGH one cycle later than shown.
2. CSA = LOW, W/RA = HIGH, MBA = LOW. It is not necessary to program offset register on consecutive clock cycles.

Figure 2. Programming the Almost-Full Flag and Almost-Empty Flag Offset Values after Reset.

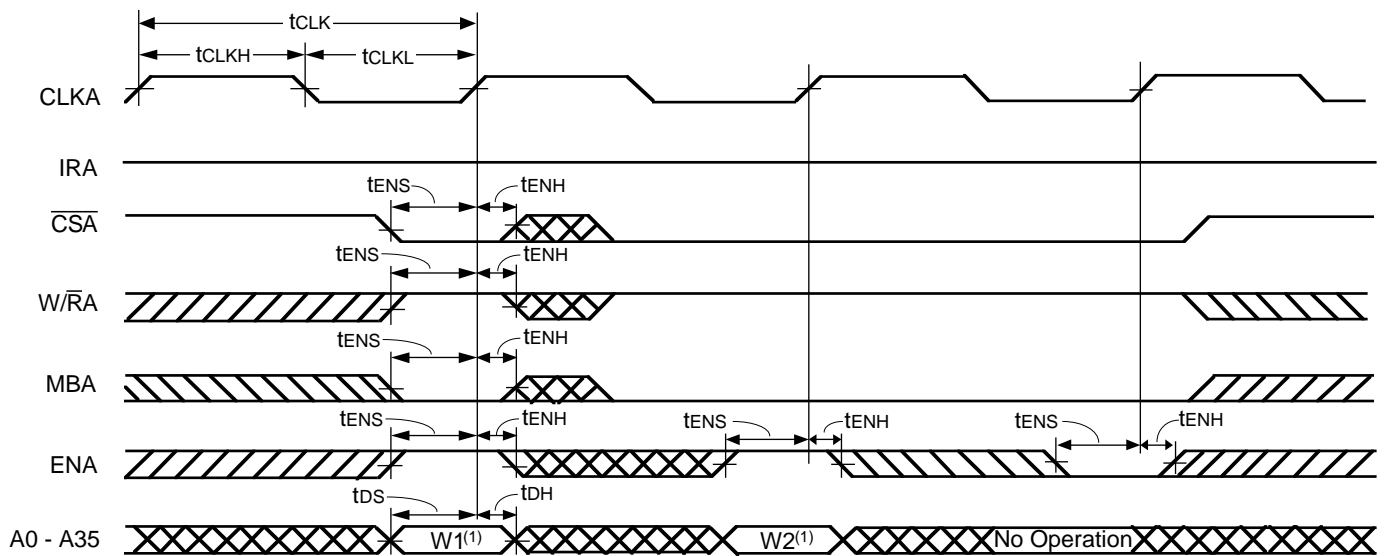

3022 drw 06

NOTE:

- 1. Written to FIFO1.

Figure 3. Port-A Write Cycle Timing for FIFO1

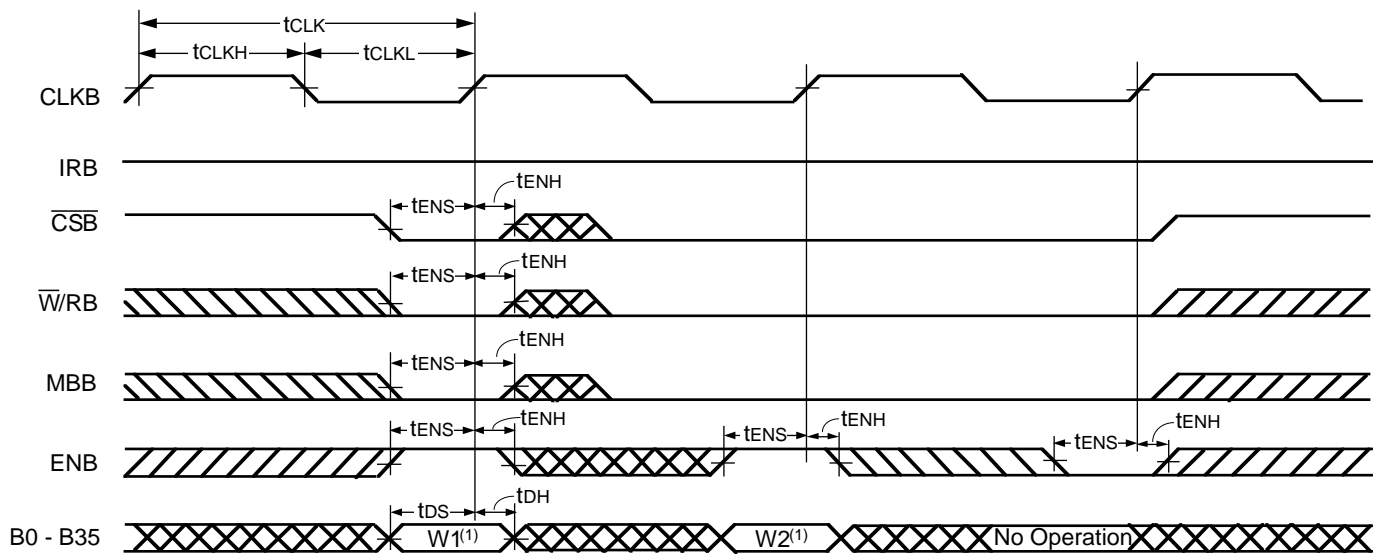

3022 drw 07

NOTE:

- 1. Written to FIFO2.

Figure 4. Port-B Write Cycle Timing for FIFO2.

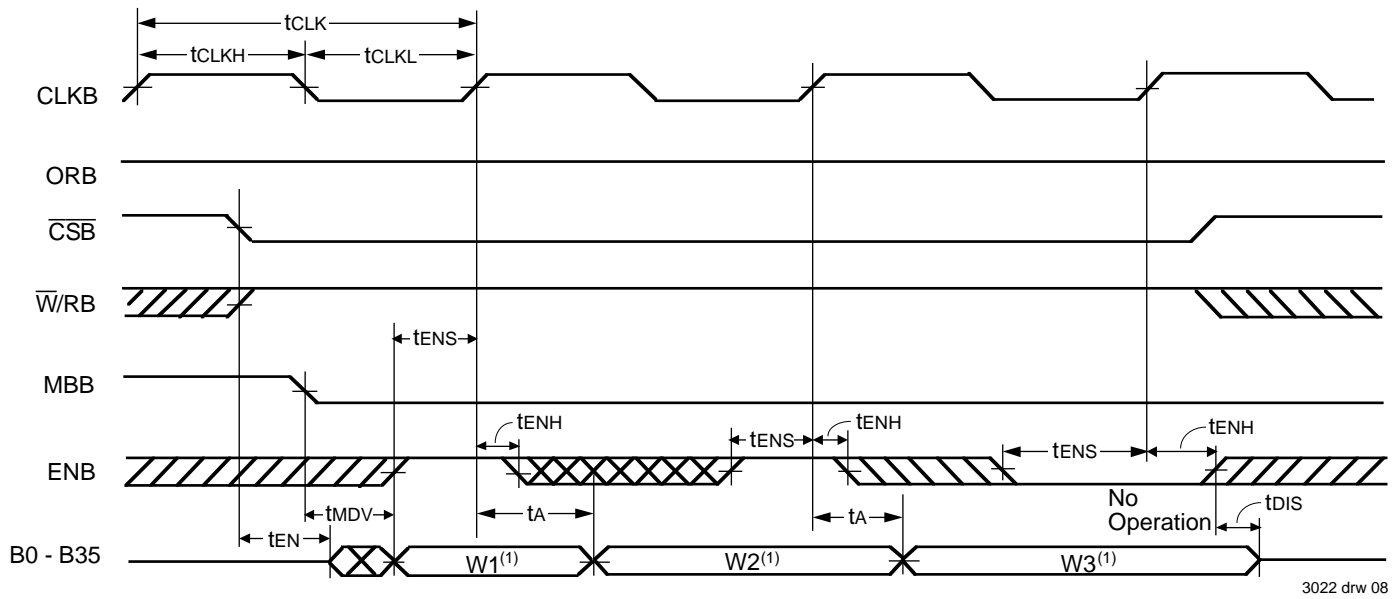

NOTE:

1. Read From FIFO1.

Figure 5. Port-B Read Cycle Timing for FIFO1.

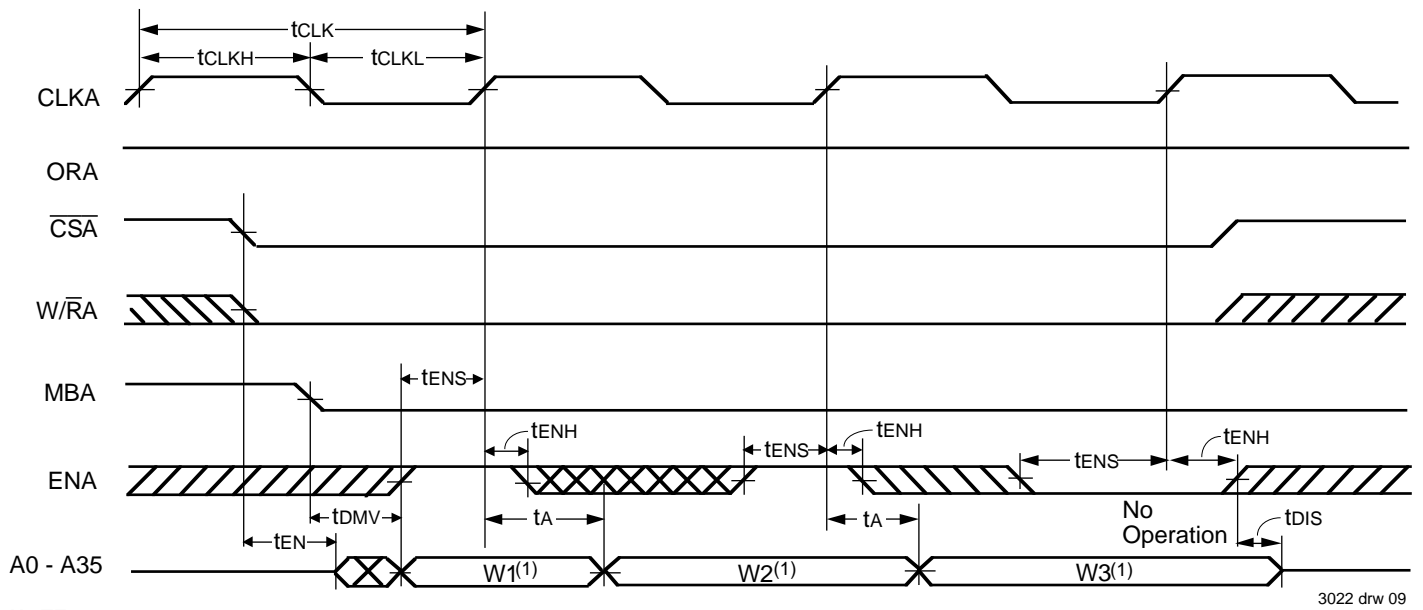

NOTE:

1. Read From FIFO2.

Figure 6. Port-A Read Cycle Timing for FIFO2.

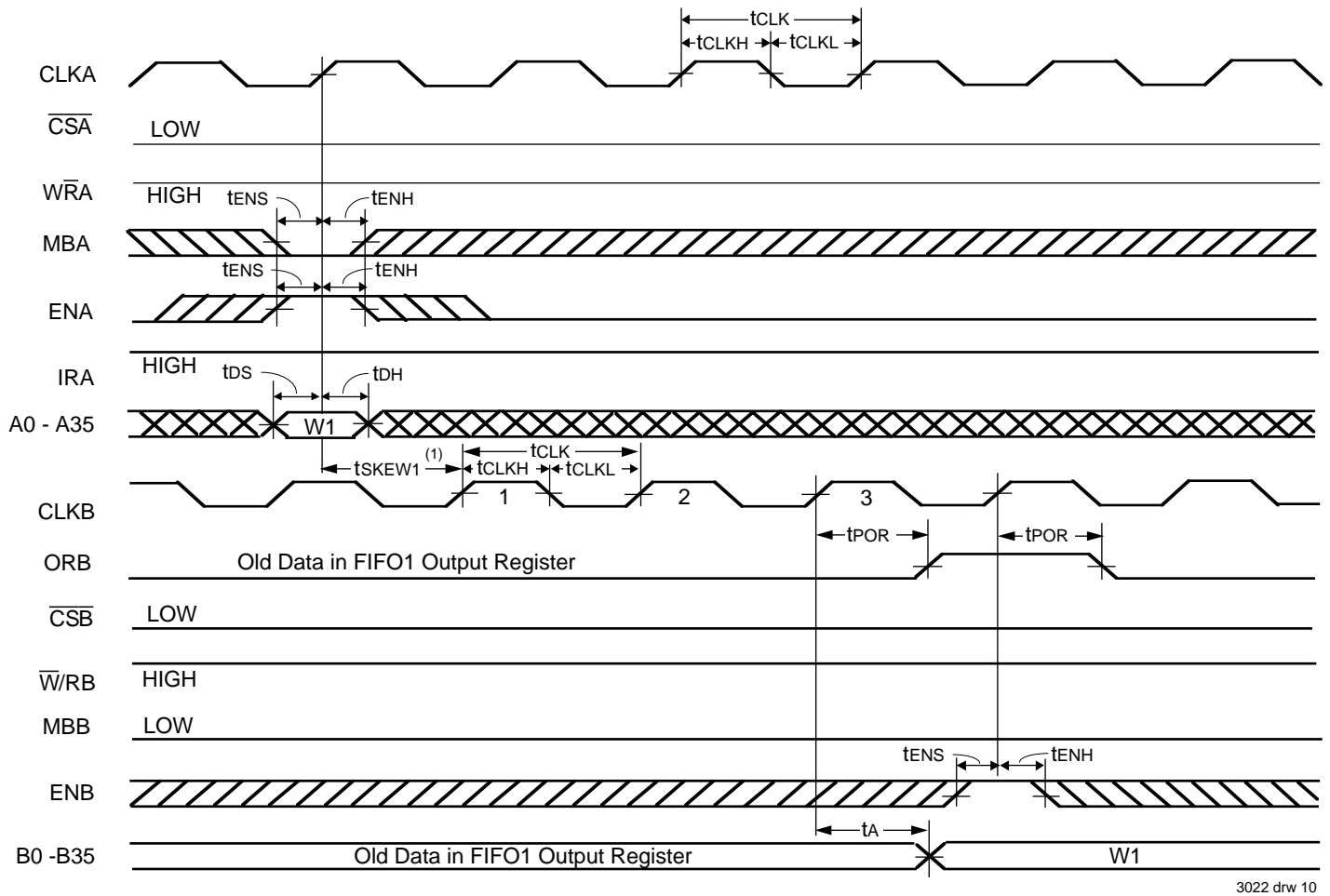

3022 drw 10

NOTE:

1. t_{SKEW1} is the minimum time between a rising CLKA edge and a rising CLKB edge for ORB to transition HIGH and to clock the next word to the FIFO1 output register in three CLKB cycles. If the time between the rising CLKA edge and rising CLKB edge is less than t_{SKEW1}, then the transition of ORB HIGH and load of the first word to the output register may occur one CLKB cycle later than shown.

Figure 7. ORB Flag Timing and First Data Word Fallthrough when FIFO1 is Empty.

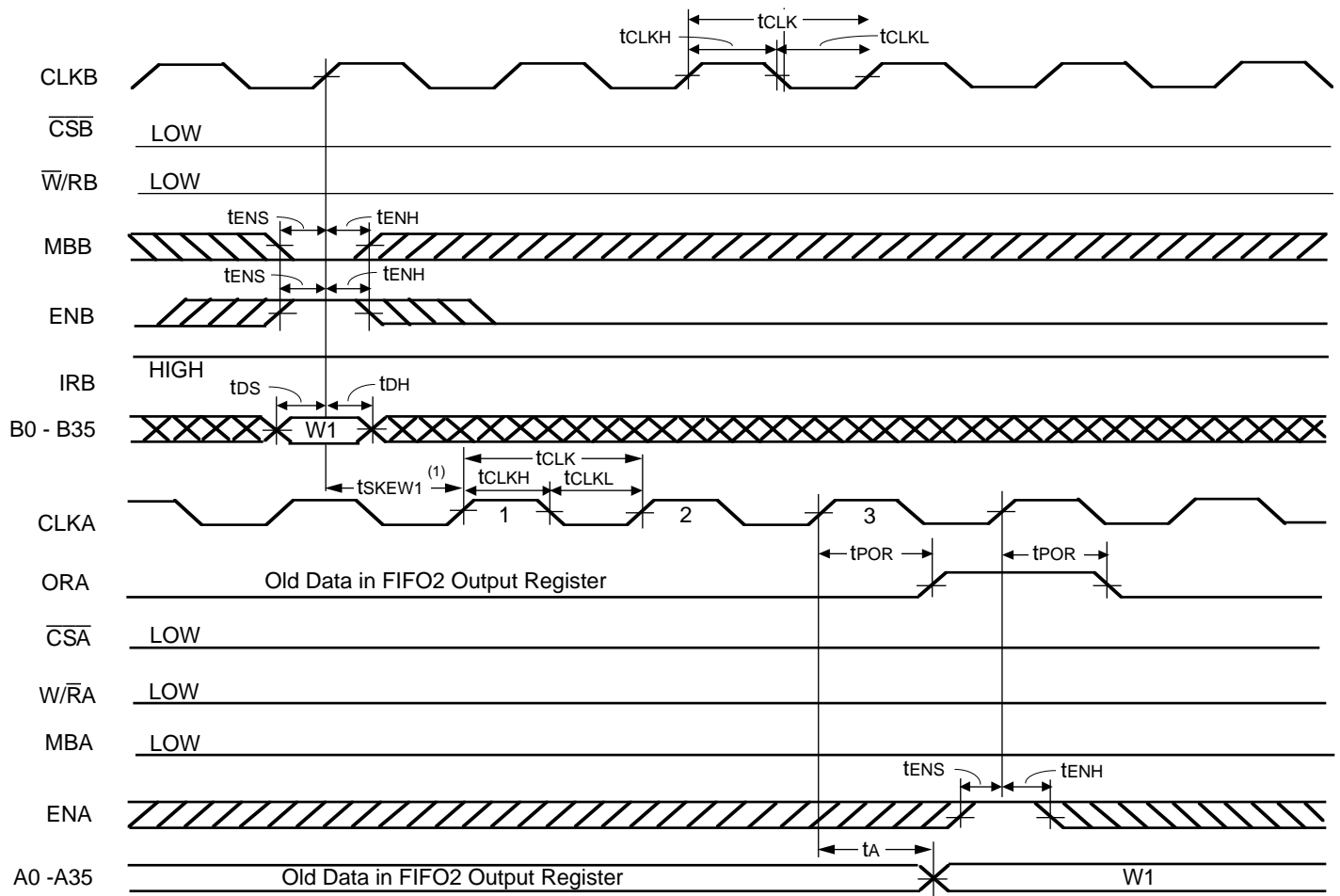

3022 drw 11

NOTE:

1. t_{SKEW1} is the minimum time between a rising CLKB edge and a rising CLKA edge for ORA to transition HIGH and to clock the next word to the FIFO2 output register in three CLKA cycles. If the time between the rising CLKB edge and rising CLKA edge is less than t_{SKEW1} , then the transition of ORA HIGH and load of the first word to the output register may occur one CLKA cycle later than shown.

Figure 8. ORA Flag Timing and First Data Word Fallthrough when FIFO2 is Empty.

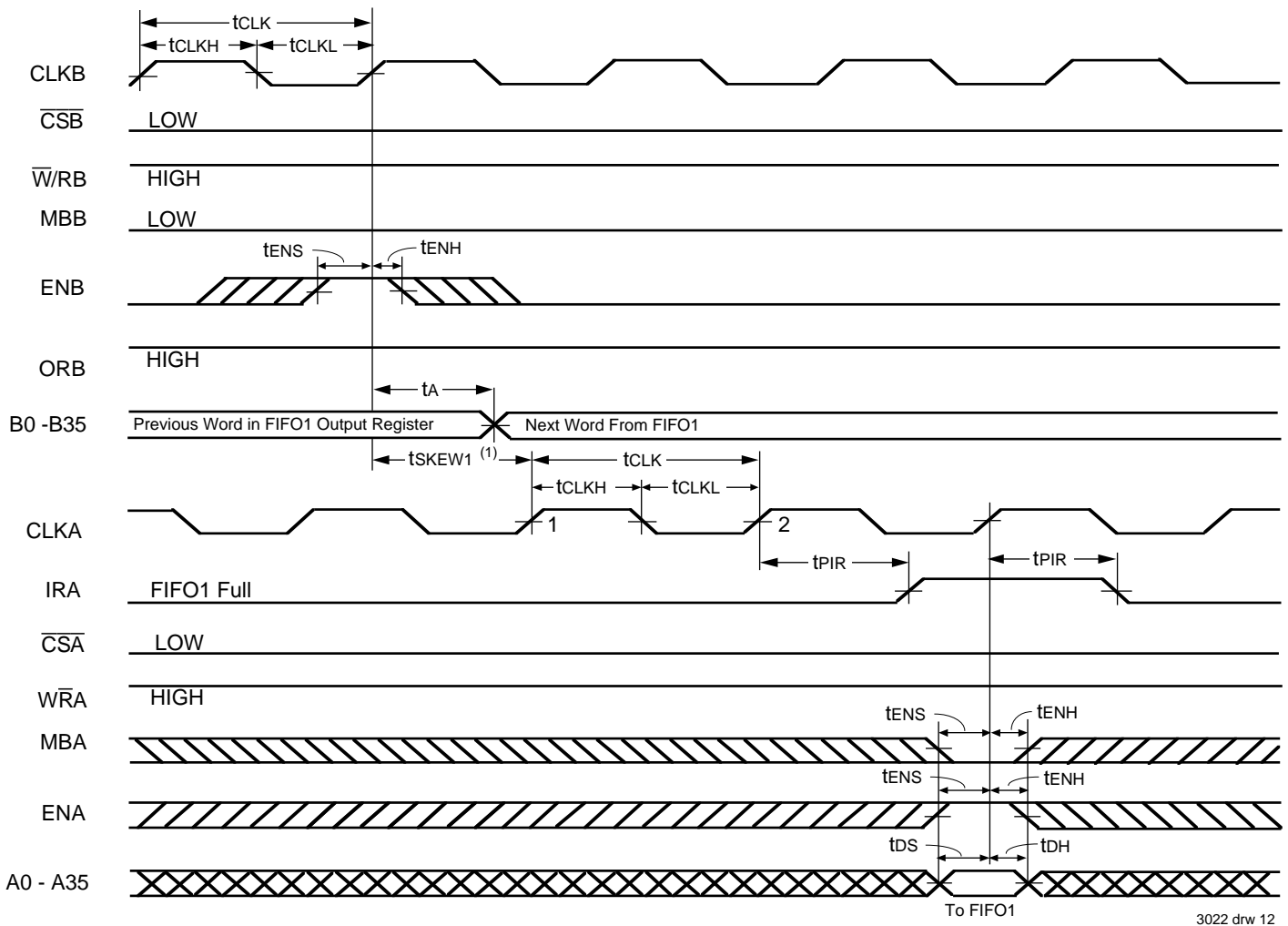

NOTE:

1. t_{sKEW1} is the minimum time between a rising CLKB edge and a rising CLKA edge for IRA to transition HIGH in the next CLKA cycle. If the time between the rising CLKB edge and rising CLKA edge is less than t_{sKEW1} , then IRA may transition HIGH one CLKA cycle later than shown.

Figure 9. IRA Flag Timing and First Available Write when FIFO1 is Full.

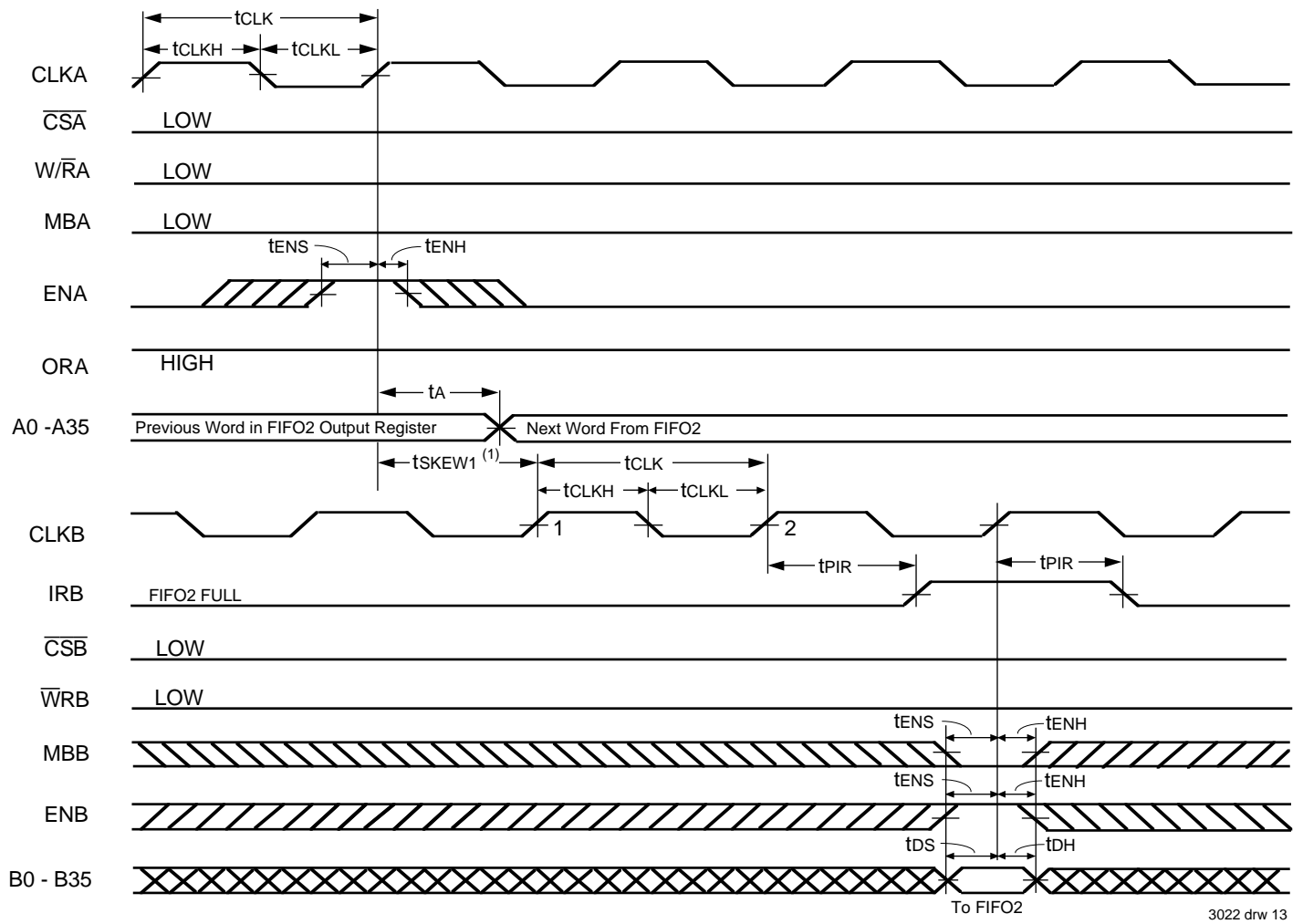

NOTE:

1. t_{SKEW1} is the minimum time between a rising CLKA edge and a rising CLKB edge for IRB to transition HIGH in the next CLKB cycle. If the time between the rising CLKA edge and rising CLKB edge is less than t_{SKEW1} , then IRB may transition HIGH one CLKB cycle later than shown.

Figure 10. IRB Flag Timing and First Available Write when FIFO2 is Full.

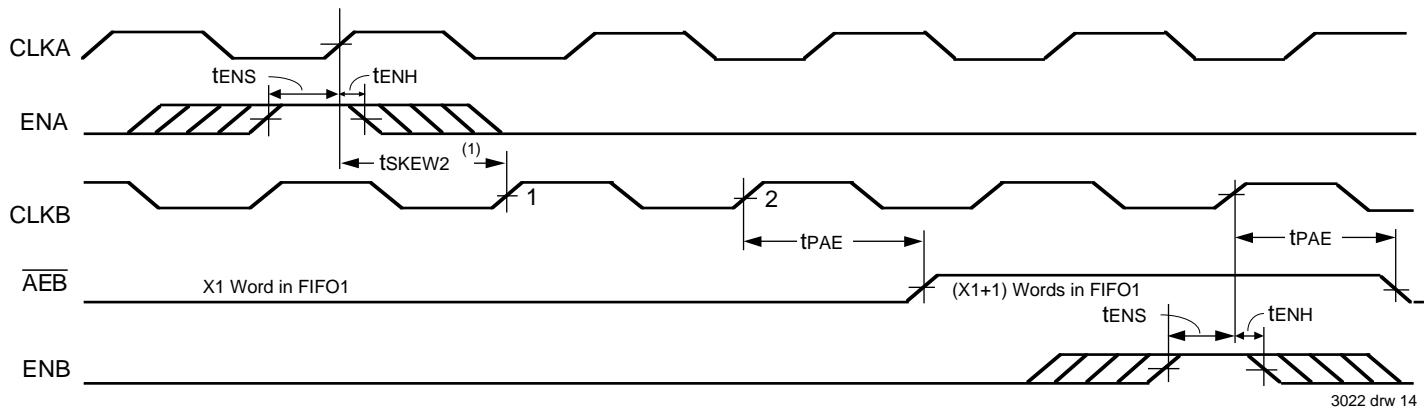

NOTES:

1. t_{SKEW2} is the minimum time between a rising CLKA edge and a rising CLKB edge for \overline{AEB} to transition HIGH in the next CLKB cycle. If the time between the rising CLKA edge and rising CLKB edge is less than t_{SKEW2} , then \overline{AEB} may transition HIGH one CLKB cycle later than shown.
2. FIFO1 Write ($\overline{CSA} = \text{LOW}$, $\overline{W/RA} = \text{LOW}$, $\overline{MBA} = \text{LOW}$), FIFO1 read ($\overline{CSB} = \text{LOW}$, $\overline{WRB} = \text{HIGH}$, $\overline{MBB} = \text{LOW}$). Data in the FIFO1 output register has been read from the FIFO.

Figure 11. Timing for \overline{AEB} when FIFO2 is Almost Empty.

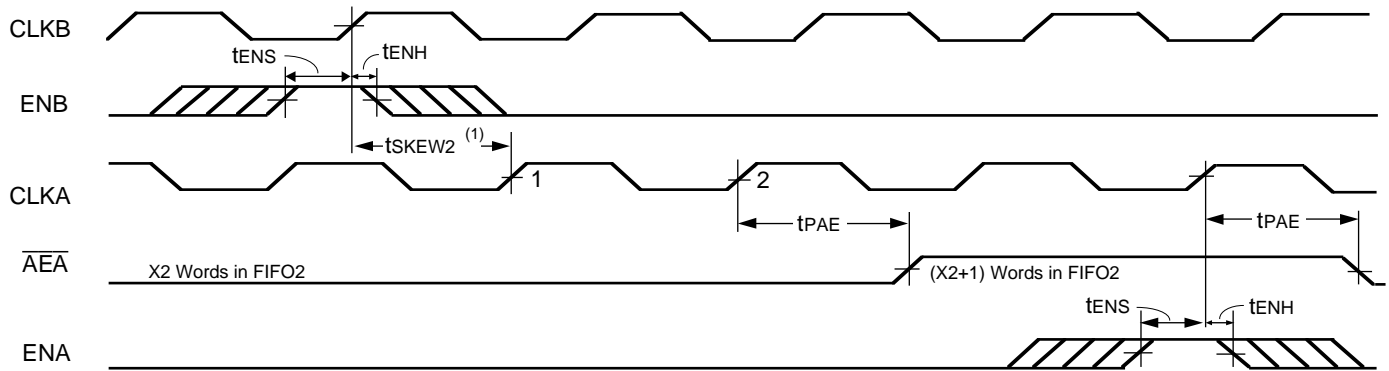

3022 drw 15

NOTES:

- t_{SKEW2} is the minimum time between a rising CLKB edge and a rising CLKA edge for $\overline{AE\overline{A}}$ to transition HIGH in the next CLKA cycle. If the time between the rising CLKB edge and rising CLKA edge is less than t_{SKEW2} , then $\overline{AE\overline{A}}$ may transition HIGH one CLKA cycle later than shown.
- FIFO2 Write ($\overline{CSB} = \text{LOW}$, $\overline{W/RB} = \text{LOW}$, $MBB = \text{LOW}$), FIFO2 read ($\overline{CSA} = \text{LOW}$, $\overline{W/RA} = \text{LOW}$, $MBA = \text{LOW}$). Data in the FIFO2 output register has been read from the FIFO.

Figure 12. Timing for $\overline{AE\overline{A}}$ when FIFO2 is Almost Empty.

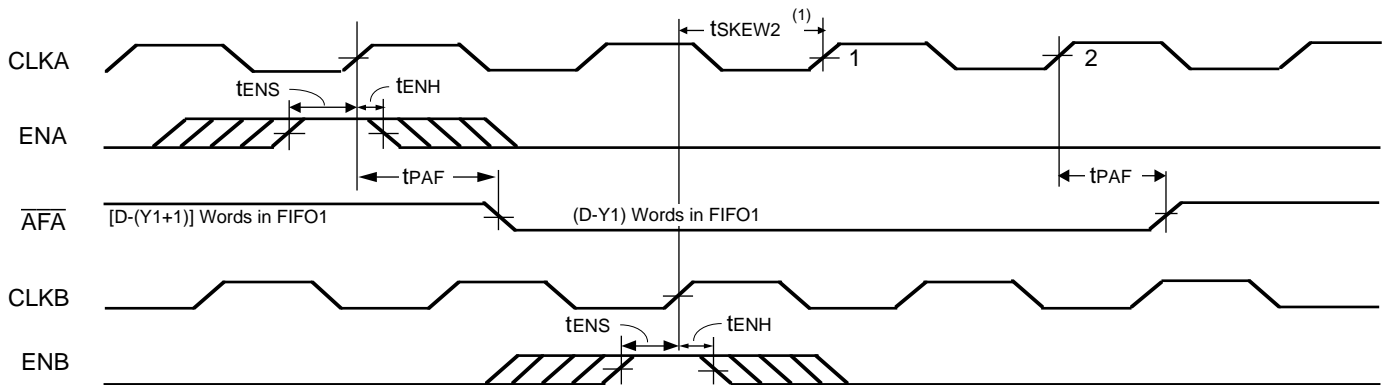

3022 drw 16

NOTES:

- t_{SKEW2} is the minimum time between a rising CLKA edge and a rising CLKB edge for $\overline{AF\overline{A}}$ to transition HIGH in the next CLKA cycle. If the time between the rising CLKA edge and rising CLKB edge is less than t_{SKEW2} , then $\overline{AF\overline{A}}$ may transition HIGH one CLKB cycle later than shown.
- FIFO1 Write ($\overline{CSA} = \text{LOW}$, $\overline{W/RA} = \text{HIGH}$, $MBA = \text{LOW}$), FIFO1 read ($\overline{CSB} = \text{LOW}$, $\overline{W/RB} = \text{HIGH}$, $MBB = \text{LOW}$). Data in the FIFO1 output register has been read from the FIFO.
- D = Maximum FIFO Depth = 256 for the 723622, 512 for the 723632, 1024 for the 723642.

Figure 13. Timing for $\overline{AF\overline{A}}$ when FIFO1 is Almost Full.

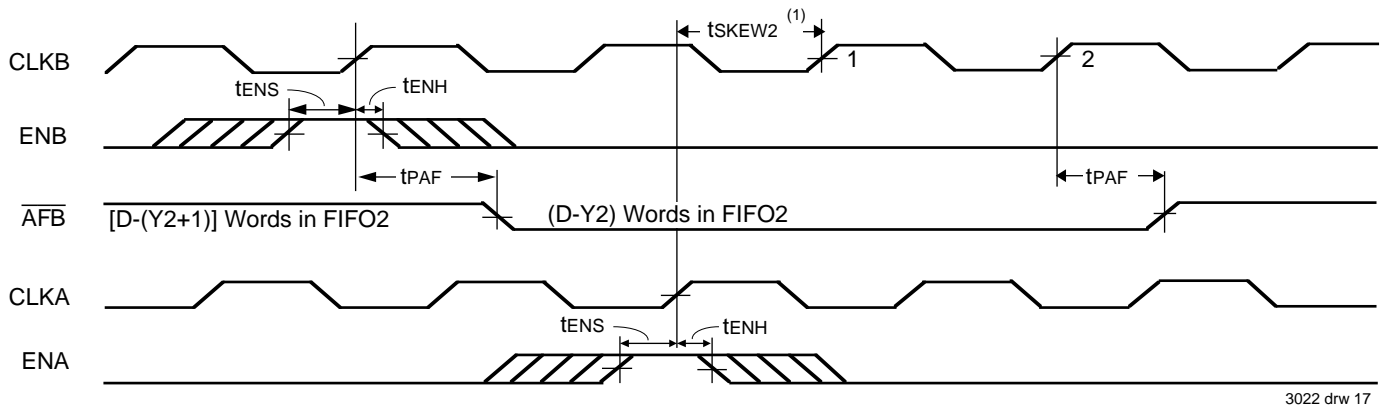

3022 drw 17

NOTES:

1. t_{sKEW2} is the minimum time between a rising CLKB edge and a rising CLKA edge for \overline{AFB} to transition HIGH in the next CLKB cycle. If the time between the rising CLKB edge and rising CLKA edge is less than t_{sKEW2} , then \overline{AFB} may transition HIGH one CLKA cycle later than shown.
2. FIFO2 write ($\overline{CSB} = \text{LOW}$, $\overline{W/RB} = \text{LOW}$, $\overline{MBB} = \text{LOW}$), FIFO2 read ($\overline{CSA} = \text{LOW}$, $\overline{W/RA} = \text{LOW}$, $\overline{MBA} = \text{LOW}$). Data in the FIFO2 output register has been read from the FIFO.
3. D = Maximum FIFO Depth = 256 for the 723622, 512 for the 723632, 1024 for the 723642.

Figure 14. Timing for \overline{AFB} when FIFO2 is Almost Full.

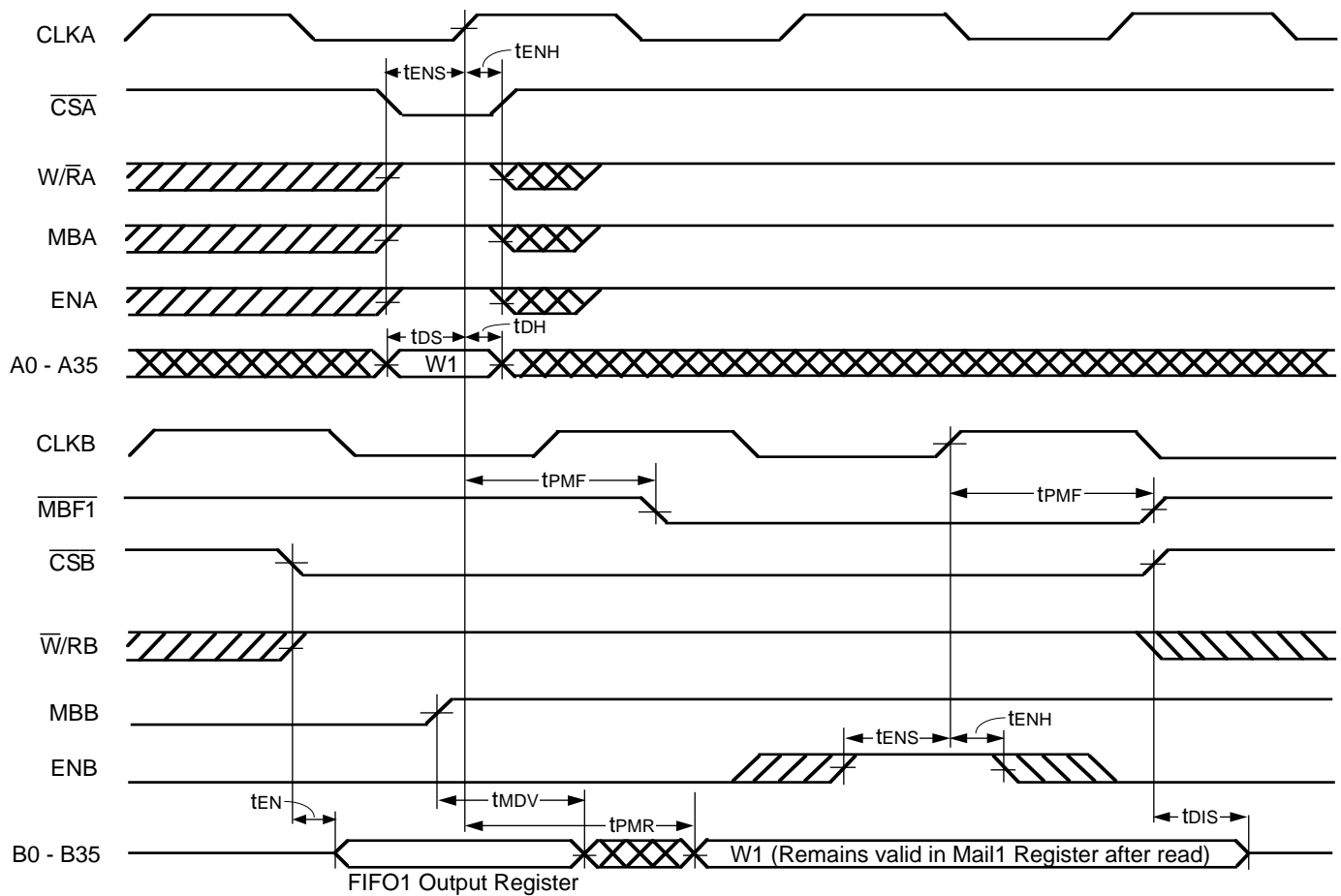

3022 drw 18

Figure 15. Timing for Mail1 Register and $\overline{MBF1}$ Flag.

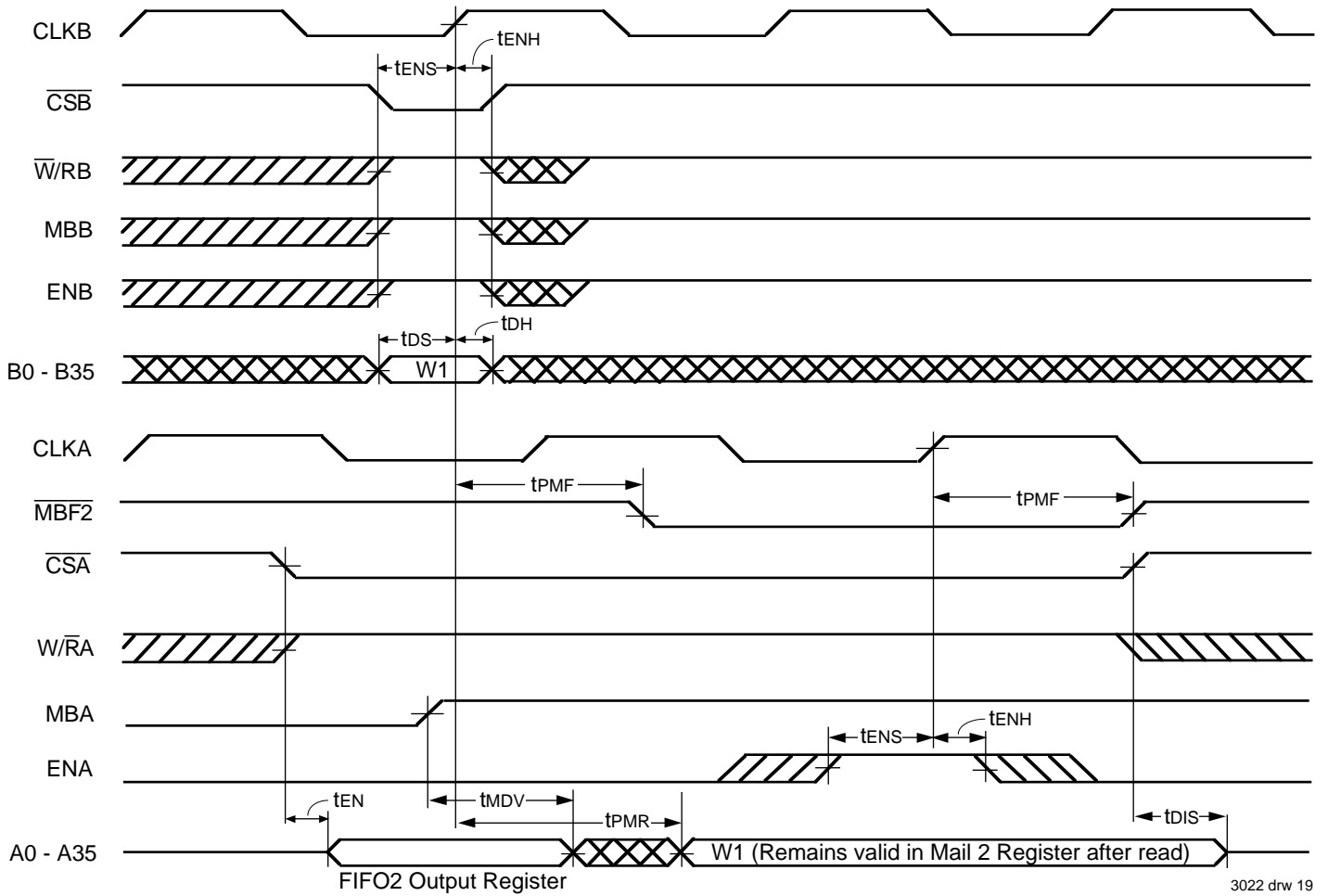
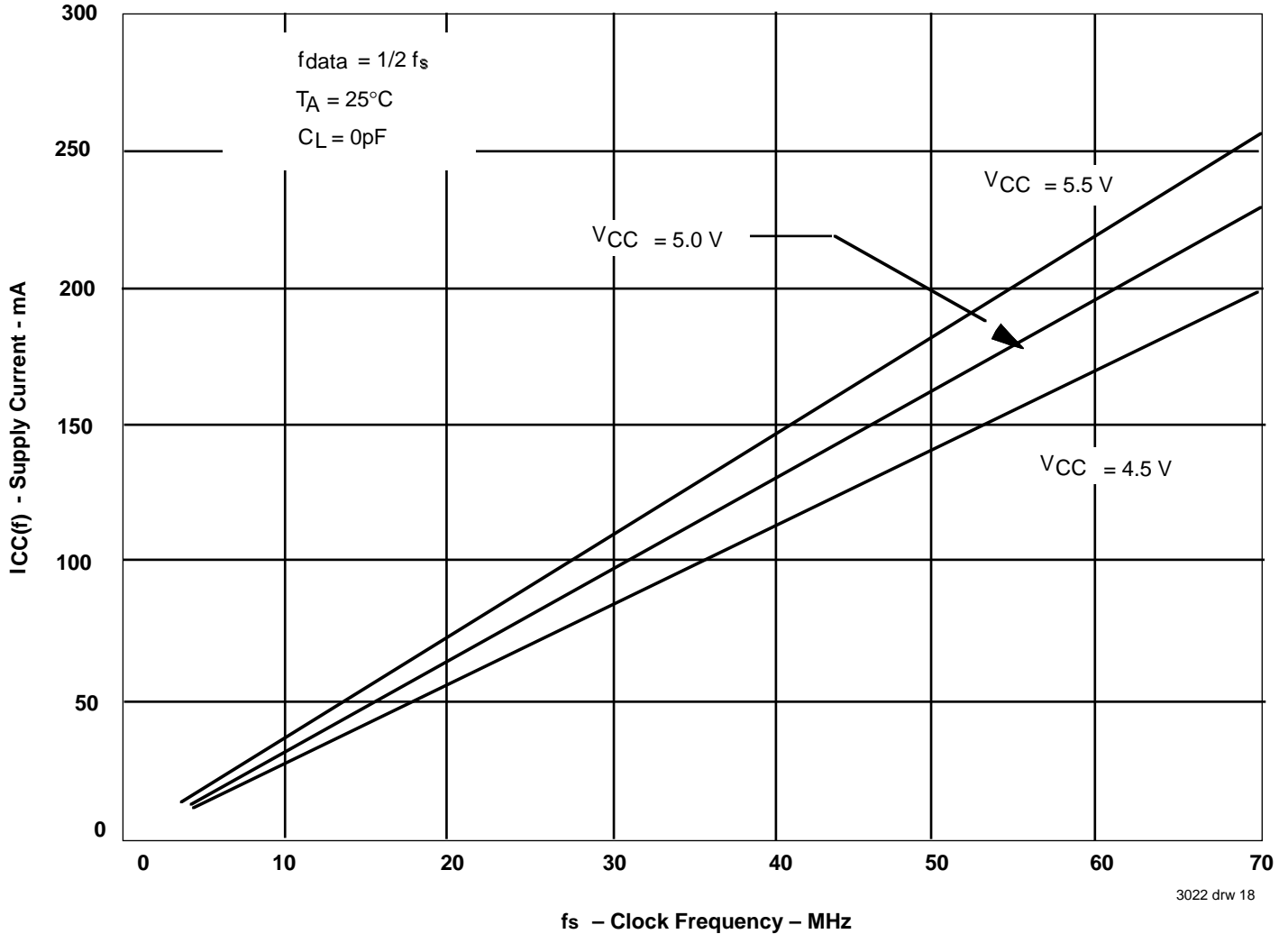

Figure 16. Timing for Mail2 Register and $\overline{MBF2}$ Flag.

TYPICAL CHARACTERISTICS
 SUPPLY CURRENT
 vs
 CLOCK FREQUENCY



fs – Clock Frequency – MHz
 Figure 17.

3022 drw 18

CALCULATING POWER DISSIPATION

The ICC(f) current for the graph in Figure 17 was taken while simultaneously reading and writing a FIFO on the IDT723622/723632/723642 with CLKA and CLKB set to fs. All data inputs and data outputs change state during each clock cycle to consume the highest supply current. Data outputs were disconnected to normalize the graph to a zero capacitance load. Once the capacitance load per data-output channel and the number of IDT723622/723632/723642 inputs driven by TTL HIGH levels are known, the power dissipation can be calculated with the equation below.

With ICC(f) taken from Figure 17, the maximum power dissipation (PT) of the IDT723622/723632/723642 may be calculated by:

$$PT = VCC \times [ICC(f) + (N \times \Delta ICC \times dc)] + \sum (CL \times VCC^2 \times fo)$$

where:

- N = number of inputs driven by TTL levels
- ΔICC = increase in power supply current for each input at a TTL HIGH level
- dc = duty cycle of inputs at a TTL HIGH level of 3.4 V
- CL = output capacitance load
- fo = switching frequency of an output

When no read or writes are occurring on the IDT723632, the power dissipated by a single clock (CLKA or CLKB) input running at frequency fs is calculated by:

$$PT = VCC \times fs \times 0.184 \text{ mA/MHz}$$

PARAMETER MEASUREMENT INFORMATION

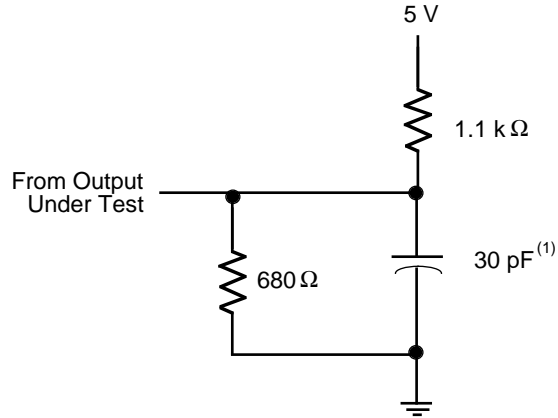

**PROPAGATION DELAY
LOAD CIRCUIT**

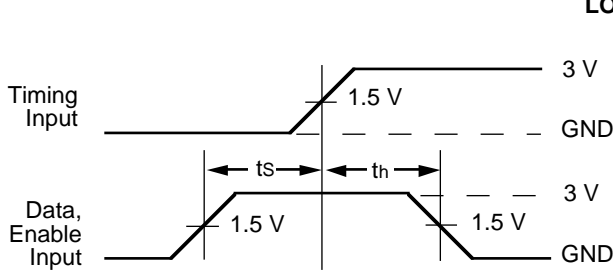

**VOLTAGE WAVEFORMS
SETUP AND HOLD TIMES**

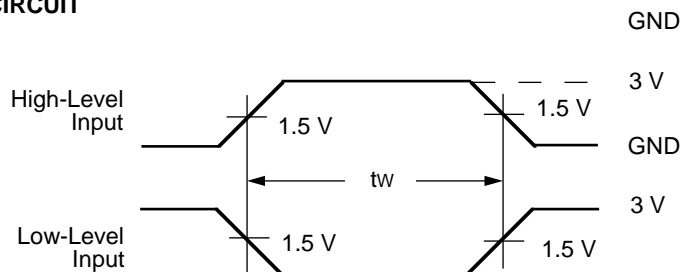

**VOLTAGE WAVEFORMS
PULSE DURATIONS**

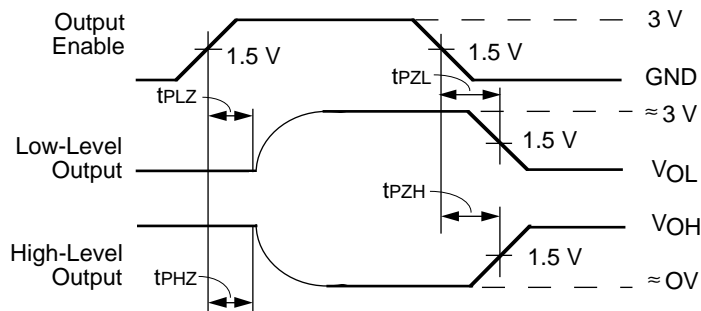

**VOLTAGE WAVEFORMS
ENABLE AND DISABLE TIMES**

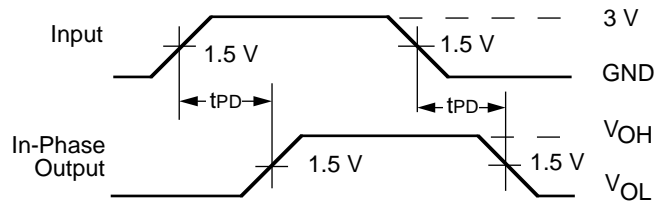

**VOLTAGE WAVEFORMS
PROPAGATION DELAY TIMES**

3022 drw 20

NOTE:

1. Includes probe and jig capacitance.

Figure 18. Load Circuit and Voltage Waveforms.

ORDERING INFORMATION

IDT	XXXXXX Device Type	X Power	XX Speed	X Package	X Process/ Temperature Range	
						BLANK Commercial (0°C to +70°C)
						PF Thin Quad Flat Pack
						PQF Plastic Quad Flat Pack
						} Commercial Only Clock Cycle Time (tCLK) Speed in Nanoseconds
					15	
					20	
						30
						L Low Power
						723622 256 x 36 Synchronous BiFIFO
						723632 512 x 36 Synchronous BiFIFO
						723642 1024 x 36 Synchronous BiFIFO

3022 drw 22