

Driver IC

Laser Diodes Driver IC

Sharp manufactures a series of driver ICs (IR3C01/R3C01/R3C01N, IR3C02A/IR2C02AN) for use as laser diode APC circuits. Using these ICs, the power output of the laser is easily adjusted by means of an external resistance. Specifications are as follows:

IR3C01/IR3C01N, IR3C02A/IR3C02AN

Pin Assignment

Pin No.	IR3C01/IR3C01N		IR3C02A/IR3C02AN	
	symbol	Function	Symbol	Function
1	OUT	Out	OUT	Output
2	IM	Monitor input	GND	Ground
3	V _{aj}	Output Setting	IM	Monitor Input
4	V _{EE}	(-) Power Supply	V _{EE}	(-)Power Supply
5	V _{IN}	Control Input (on/off)	V _{IN}	Control Input (on/off)
6	GND	Ground	S _o	Operating signal output
7	C _p	Phase Compensation	C _p	Phase Compensation
8	V _{CC}	(+) Power Supply	V _{CC}	(+) Power Supply

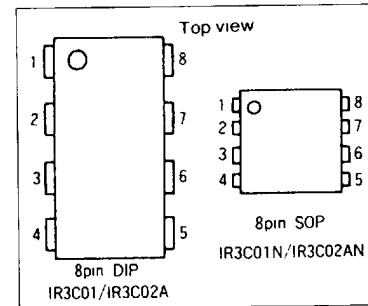

Absolute Maximum Ratings

(T_a=25°C)

Parameter	Symbol	Remarks	Ratings		Units
			IR3C01/IR3C01N	IR3C02A/IR3C02AN	
Supply Voltage	V _{CC}		13	10	V
Supply Voltage	V _{EE}		-20	-10	V
Output Current	I _o	Pin ①	170	-170	mA
Control Input Voltage	V _{IN}	Pin ⑤	-0.2 to 6	-0.2 to V _{CC}	V
Power Dissipation	P _c	T _a ≤ 25°C	450/330	550/500	mW
Derating ratio	—	T _a > 25°C	4.6/3.3	4.4	mW/°C
Operating Temperature	T _{opr}		-20 to +85	-30 to +85	°C
Storage Temperature	T _{stg}		-55 to +150	-55 to +150	°C
Output Current	I _{os}	Pin ⑥ with laser on	—	5	mA
Output Applied Voltage	V _{os}	Pin ⑥ with laser off	—	-0.2 - V _{CC}	V

Electrical Characteristics

(a) IR3C01/IR3C01N

(V_{CC}=-5V, V_{EE}=-12V, T_a=25°C)

Parameter	Symbol	Condition	Rating			Units
			MIN	TYP	MAX	
Operating Supply Voltage	V _{CC}	— —	4.5	5.0	5.5	V
	V _{EE}	— —	-10.0	-12.0	-13.2	V
Circuit Current	I _{CC}	V _{IN} =0V	—	2.8	4.5	mA
	I _{EE OFF}	V _{IN} =0V	—	-1.3	-2.1	mA
	I _{EE ON}	V _{IN} =5V	—	-2.8	-4.6	mA
Output Voltage	V _{OUT}	I _o =150mA	3.6	4.1	—	V
		I _o =100mA	3.7	4.2	—	V
		I _o =20mA	3.8	4.3	—	V
Control Input Voltage (H)	V _{INH}	— —	2.0	—	6	V
Control Input Voltage (L)	V _{INL}	— —	0	—	0.8	V
Control Input Current	I _{IN}	V _{IN} =5V	—	0.3	0.5	mA
Monitor Input pin Voltage	V _M	— —	—	-6.9	—	V
Output Adjustment Pin Voltage	V _{aj}	(V _{aj} -V _{EE})	3.5	3.9	4.3	V
Power Supply Ripple Reduction	ΔI _o /ΔV _{CC}	f=120Hz	—	4×10 ⁻⁵	—	A/V
	ΔI _o /ΔV _{EE}	f=120Hz	—	1×10 ⁻⁶	—	A/V

(b) IR3C02A/IR3C02AN

(V_{CC}=5V, V_{EE}=-5V, T_a=25°C)

Parameter	Symbol	Condition	Rating			Units	
			MIN	TYP	MAX		
Operating Supply Voltage	V _{CC}	— —	4.5	5.0	5.5	V	
	V _{EE}	— —	-4.5	-5.0	-5.5	V	
Circuit Current	I _{CC ON}	V _{IN} =5V	—	2.8	5.0	mA	
	I _{EE ON}		—	-2.0	-5.0		
	I _{CC OFF}	V _{IN} =0V	—	4.1	7.5	mA	
	I _{EE OFF}		—	-2.1	-3.8		
Output Voltage	V _{OUT}	I _o =-150mA	3.7	4.1	—	V	
		I _o =-100mA	3.8	4.2	—	V	
		I _o =-20mA	3.9	4.3	—	V	
Output Voltage	V _{OS1}	I _{os} =0mA, V _{IN} =0V	—	0.05	—	V	
		V _{OS2}	I _{os} =2mA, V _{IN} =0V	—	—	0.4	V
Control Input Voltage	H	V _{IN H}	V _O V _{OS} L→H	1.43	1.53	1.63	V
	L	V _{IN L}	V _O V _{OS} H→L	1.23	1.33	1.43	V
Voltage Hysteresis	V _{IN HY}	(V _{INH} -V _{INL})	—	200	—	mV	
Control Input Current	I _{IN}	— —	—	-0.3	—	μA	
Monitor Input Pin Voltage	V	— —	1.16	1.22	1.28	V	
Monitor Input Pin Current	I	— —	—	-0.3	-5	μA	
Photo output power supply change	ΔP/ΔV _{CC}	V _{EE} =-5V, V _{CC} =5V±10%	—	0.02	—	%/V	
		V _{CC} =-5V, V _{EE} =-5V±10%	—	0.2	—	%/V	
Photo output changing width	ΔP/I _{PO}	T _a =-30 to +85°C	—	0.2	—	%	

Common Data

Fig. 94-1 Optical Power Output Dependence of Far-Field Pattern

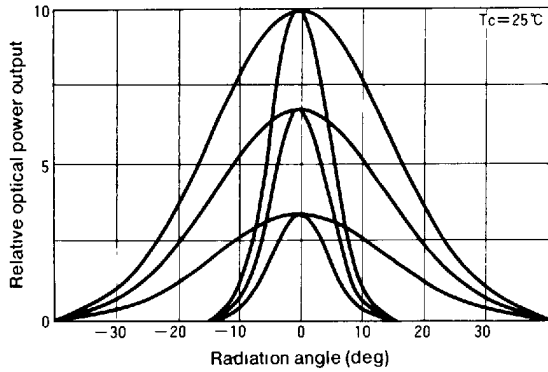

Fig. 94-4 Coupling Efficiency

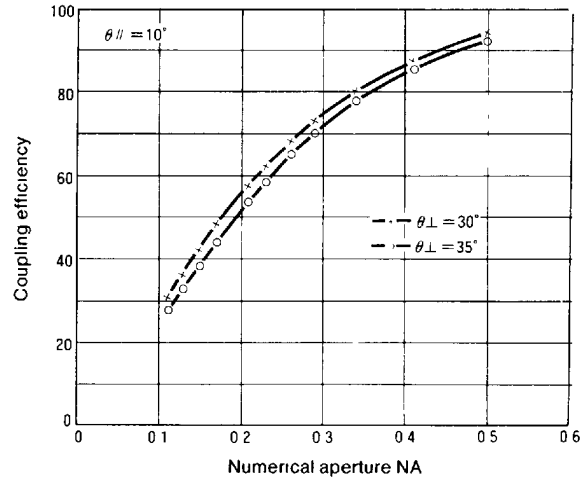

Fig. 94-2 Polarization Ratio vs. Optical Power Output (LT026 series, LT023 series)

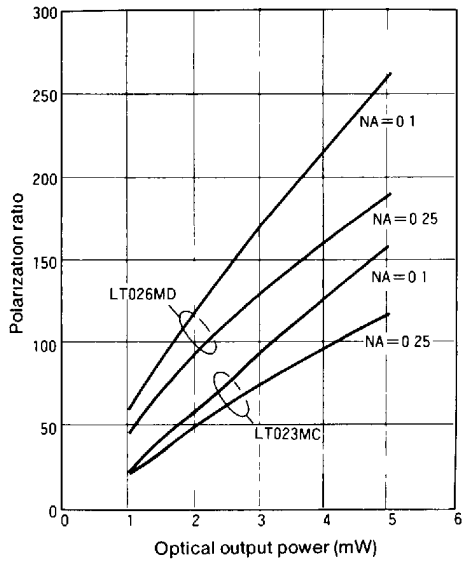

Fig. 94-5 Frequency Response

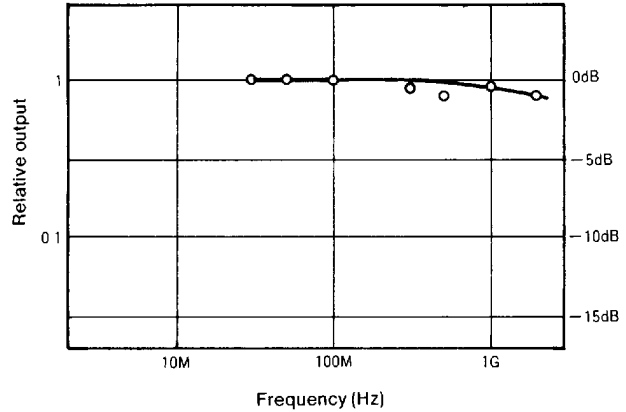
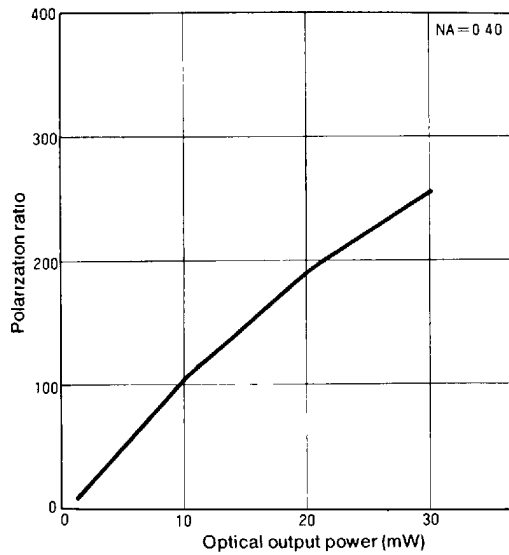

Fig. 94-3 Polarization Ratio vs. Optical Power Output (LT024 series, LT015 series)



Note All data on this page is typical only, and is not intended as a specification. The shapes of these curves can be used as a general reference, but the actual characteristics will vary from device to device.

Built-in PIN Photodiode Characteristics

Fig. 95-1 Photodiode Frequency Response Characteristic

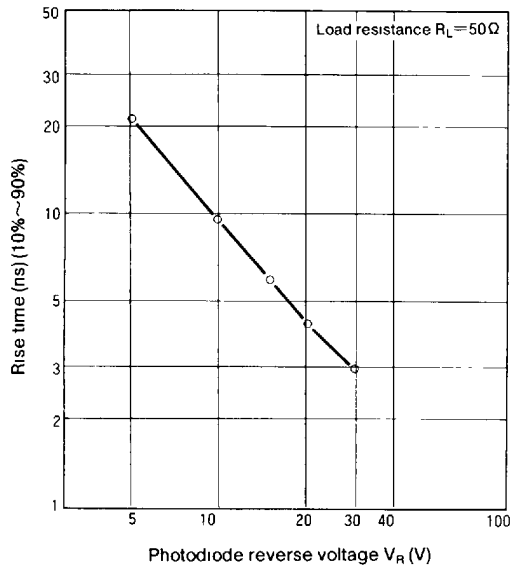
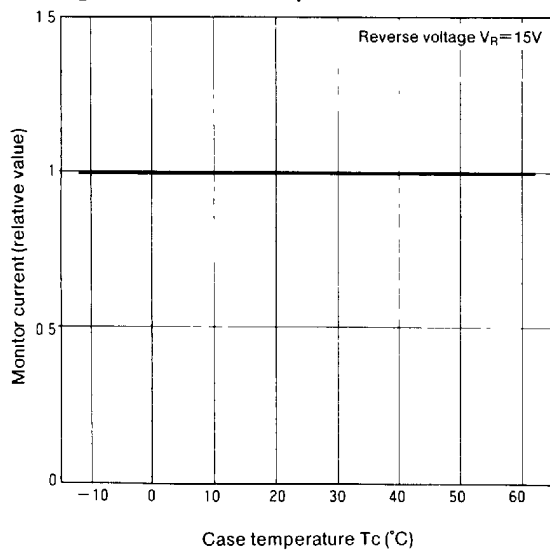

Fig. 95-2 Photodiode Temperature Characteristic



Note All data on this page is typical only, and is not intended as a specification. The shapes of these curves can be used as a general reference, but the actual characteristics will vary from device to device.

Outline Dimensions

Unit: mm

Fig. 98-1 Standard Type (C Type)

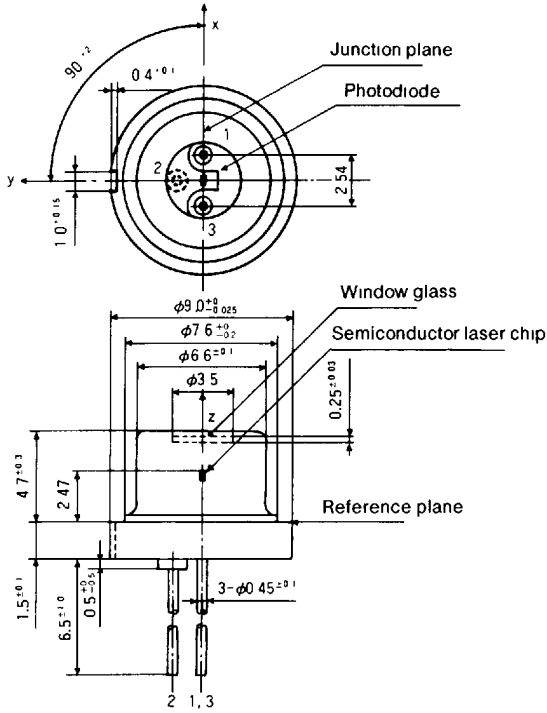

Fig. 98-2 Low-Cap Type (D Type)

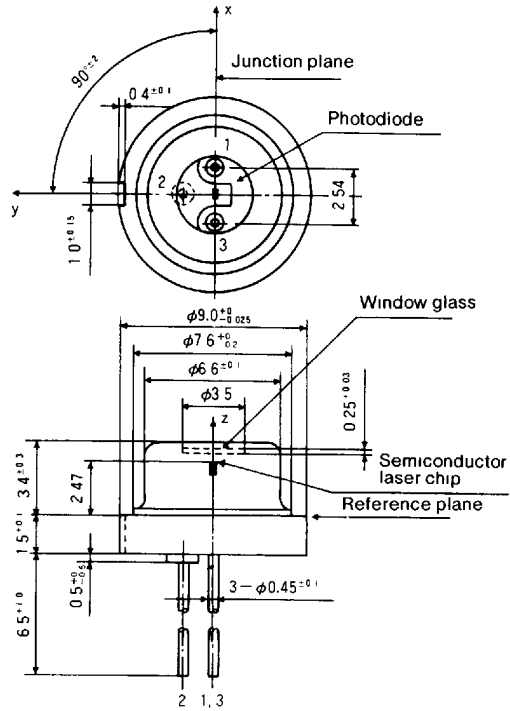

Fig. 98-3 Fin-Equipped Type (F Type)

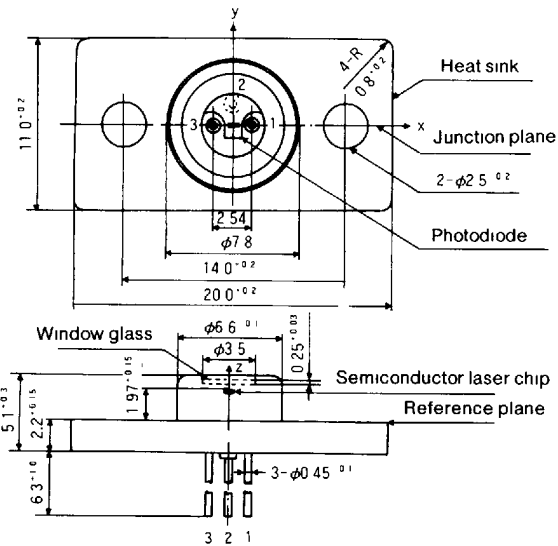
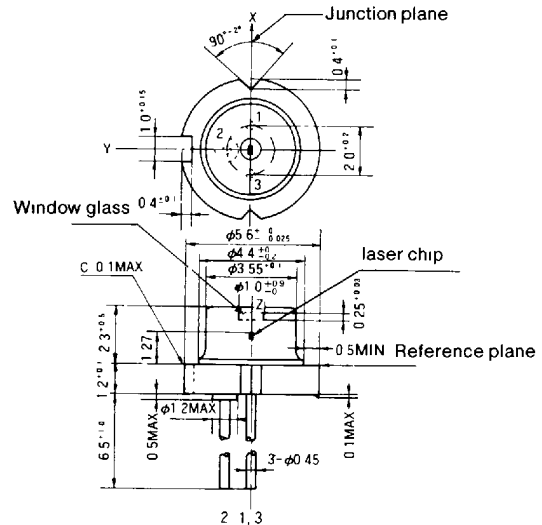

Fig. 98-4 Compact Package Type (S Type)



Terminal connections

