

ATF for 8mm VTR

**Description**

CXA1204 is an IC for ATF\* for 8mm VTR, in which all the functions necessary for ATF operations are incorporated.

**Features**

- All the functions can be configured with a limited number of peripheral components, permitting reduction and stabilization of the set.
- A record pilot signal generating circuit is incorporated.
- A BPF for ATF error signals,  $f_H$  and  $3f_H$  is incorporated.
- A circuit for switching over between  $f_H$  and  $3f_H$  is incorporated.
- An AGC circuit for playback signal is incorporated.

**Applications**

8mm VTR

**Structure**

Bi-CMOS IC

**Absolute Maximum Ratings (Ta=25°C)**

• Supply voltage	V <sub>cc</sub>	6	V
• Storage temperature	T <sub>stg</sub>	-50 to +150	°C
• Allowable power dissipation	P <sub>D</sub>	500	mW

**Recommended Operating Conditions**

• Supply voltage	V <sub>cc</sub>	4.75 to 5.25	V
• Operating temperature	T <sub>opr</sub>	-10 to +75	°C

**Principal Electrical Characteristics**

• Supply voltage		5 ± 0.25	V
• Supply current	In recording	13	mA
	In playback	24	mA

**Package Outline**

Unit: mm

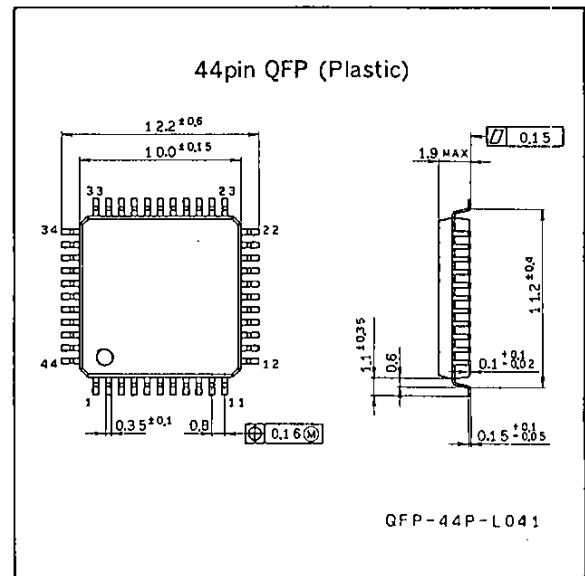

Block Diagram

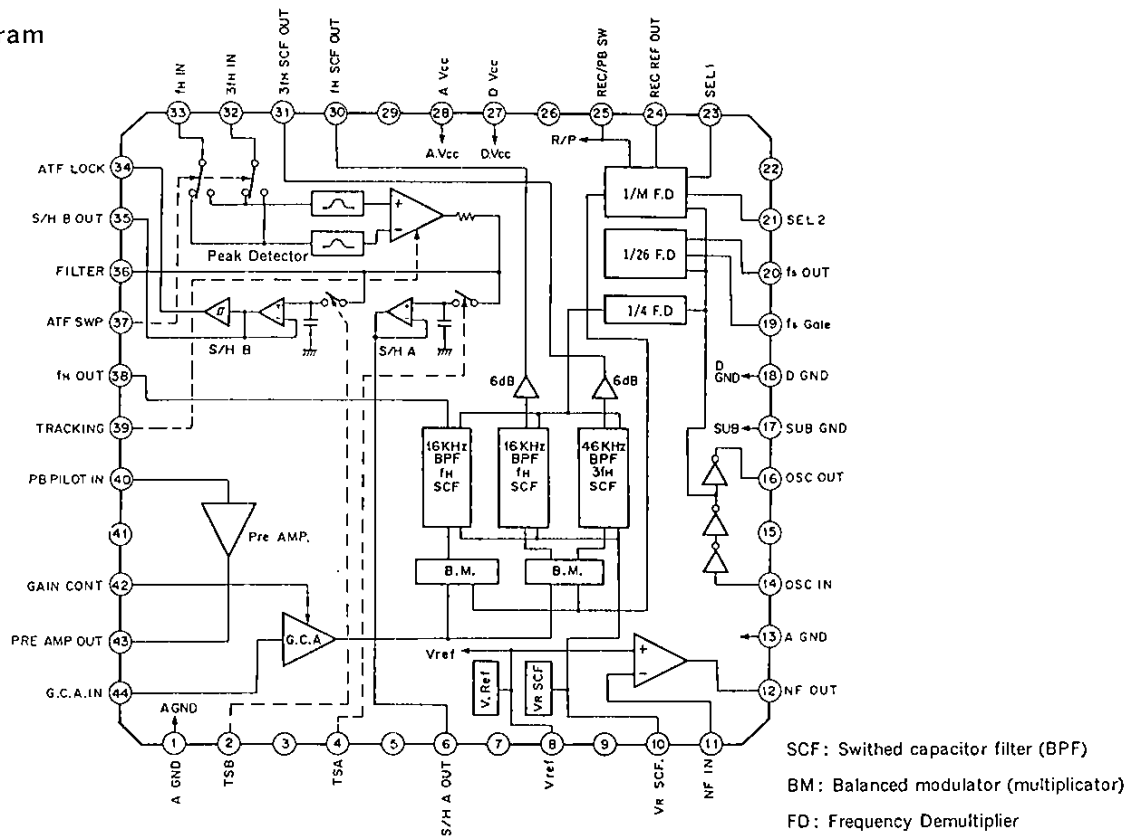

Pin Description

(V<sub>cc</sub>=5.0V, T<sub>a</sub>=25°C)

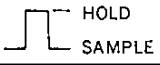
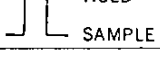
No.	Symbol	Standard DC voltage	Input-output impedance	Standard AC voltage	Remarks
1	A-GND	—	—	—	Analog amp. GND
2	TSB	—	—		H: at least 3.5V L: up to 0.5V
3	N.C.	—	—	—	—
4	TSA	—	—		H: at least 3.5V L: up to 0.5V
5	N.C.	—	—	—	—
6	S/H A OUT	2.5V	—	—	—
7	N.C.	—	—	—	—
8	V <sub>Ref</sub>	2.5V	30Ω	—	For analog amp. Standard voltage
9	N.C.	—	—	—	—
10	V <sub>R</sub> S.C.F.	1.25V	100Ω	—	Standard voltage for S.C.F.
11	NF IN.	(2.5V)	Open base	—	—
12	NF OUT	(2.5V)	S.E.P.P.	—	—
13	A-GND	—	—	—	Analog amp. GND
14	OSC IN	—	Open gate	5.9MHz sine wave*1	—

\* 1 { NTSC—378f<sub>H</sub>  
PAL—375f<sub>H</sub>

Pin Description

(Vcc=5.0V, Ta=25°C)

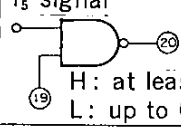
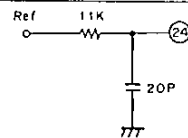
No.	Symbol	Standard DC voltage	Input-output impedance	Standard AC voltage	Remarks
15	N.C.	—	—	—	—
16	OSC OUT	—	Emitter follower output	5Vp-p square wave	—
17	SUB GND	—	—	—	IC SUB-GND
18	D.GND	—	—	—	SCF divider, oscillator GND
19	f <sub>s</sub> GATE	—	Open gate	—	f <sub>s</sub> signal
20	f <sub>s</sub> OUT	—	—	5Vp-p square wave	 H: at least 3.5V L: up to 0.5V
21	SEL2	Note	Open gate	—	H: at least 3.5V L: up to 0.5V
22	N.C.	—	—	—	—
23	SEL1	Note	Open gate	—	H: at least 3.5V L: up to 0.5V
24	Rec, Ref Output	—	11kΩ	3.75Vp-p	
25	REC/PB SW	High; PB Low; REC	Open gate	—	H: at least 3.5V L: up to 0.5V
26	N.C.	—	—	—	—
27	D. Vcc	(5V)	—	—	SCF divider, oscillator power supply
28	A. Vcc	(5V)	—	—	Analog power supply
29	N.C.	—	—	—	—
30	f <sub>H</sub> SCF OUT	1.3V	200Ω	—	—
31	3f <sub>H</sub> SCF OUT	2.4V	200Ω	—	—
32	3f <sub>H</sub> IN	2.5V	10kΩ	—	—
33	f <sub>H</sub> IN	2.5V	10kΩ	—	—
34	ATF LOCK	—	Open collector	—	—
35	S/H B OUT	2.5V	—	—	—
36	FILTER	2.5V	—	—	—
37	ATF SWP	—	Open gate	—	H: at least 3.5V ③⑨ = 3f <sub>H</sub> - f <sub>H</sub> L: up to 0.5V ③⑥ = f <sub>H</sub> - 3f <sub>H</sub>
38	f <sub>H</sub> ERROR OUT	2.6V	—	—	—
39	TRACKING	1.8V	27kΩ	—	—

## Pin Description

(V<sub>CC</sub>=5.0V, T<sub>a</sub>=25°C)

No.	Symbol	Standard DC voltage	Input-output impedance	Standard AC voltage	Remarks
40	PB PILOT IN	1.8V	10kΩ	PB PILOT	—
41	N.C.	—	—	—	—
42	GAIN CONT	—	Open base	—	—
43	PRE AMP OUT	1.5V	100Ω	—	—
44	G.C.A.IN	3.1V	850Ω	—	—

## Electrical Characteristics

(V<sub>CC</sub>=5.0V, T<sub>a</sub>=25°C)

Item	Symbol	Condition	Min.	Typ.	Max.	Unit
Playback mode, current consumption	I <sub>PB</sub>	S1 to S7=1 Current on ammeter ④ is measured.	16	22	32	mA
Record mode (power save), current consumption	I <sub>REC</sub>	S1 to S7=1, V <sub>PB</sub> Current on ammeter ④ is measured.	—	8	13	mA
Pre-amp. gain	G <sub>pre</sub>	S1=3, S2=2, others=1 SG1; f=118.95kHz, 3mVp-p $G_{pre}=20\log\frac{V_{43}}{3}$ (dB)	24	28	32	dB
GCA+multiplier +16k BPF gain (1)	G <sub>30/44</sub>	S1=2, others=1 V <sub>C21</sub> =V <sub>C23</sub> =5V, V <sub>GCA</sub> =3.2V SG2; f=118.95kHz, 20mVp-p $G=20\log\frac{V_{30}}{20}$ (dB)	27	30	35	dB
GCA+multiplier +16k BPF gain (2)	G <sub>38/44</sub>	S1=2, others=1 V <sub>C21</sub> =V <sub>C23</sub> =5V, V <sub>GCA</sub> =3.2V SG2; f=118.95kHz, 20mVp-p $G=20\log\frac{V_{30}}{20}$ (dB)	21	24	29	dB
GCA+multiplier +46k BPF gain	G <sub>31/44</sub>	S1=2, others=1 V <sub>C21</sub> =V <sub>C23</sub> =5V, V <sub>GCA</sub> =3.2V SG2; f=148.69kHz, 20mVp-p $G=20\log\frac{V_{31}}{20}$ (dB)	27	30	34.5	dB
GCA Gain variable width	ΔG	S1=2, others=1 SG2; f=118.95kHz, 20mVp-p Dif- ference in gain between V <sub>GCA</sub> =4.0V and V <sub>GCA</sub> =2.5V Measuring pin 38 ΔG=G-G' where, $G=20\log\frac{V_{38}}{20}$ $G'=20\log\frac{V'_{38}}{20}$	7	14	—	dB

## Electrical Characteristics

(V<sub>CC</sub>=5.0V, T<sub>a</sub>=25°C)

Item	Symbol	Condition	Min.	Typ.	Max.	Unit							
16kHz BPF characteristics (1)	F <sub>0</sub> frequency (design guarantee)	F <sub>0</sub> (16k)	S1=2, others=1 SG2; f=100k to 200k, 20mVp-p (SWP time 99sec) V <sub>C21</sub> =V <sub>C23</sub> =5V measuring instrument spectrum analyzer Max Hold SCAN 0.2sec	V <sub>30</sub> is monitored by spectrum analyzer to measure frequency at which peak is reached.	16.08	16.46	16.84	kHz					
	9kHz damping	9k							V <sub>30</sub> is monitored by spectrum analyzer to measure level difference between 9kHz and 28kHz relative to 16.46kHz.	—	—	-20	dB
	28kHz damping	28k											
	102.54kHz damping (design guarantee)	102.54k											
16kHz BPF characteristics (2)	F <sub>0</sub> frequency (design guarantee)	F <sub>0</sub> ' (16k)	S1=2, others=1 SG2; f=100k to 200k, 20mVp-p (SWP time 99sec) V <sub>C21</sub> V <sub>C23</sub> =5V measuring instrument spectrum analyzer Max Hold SCAN 0.2sec	V <sub>38</sub> is monitored by spectrum analyzer to measure frequency at which peak is reached.	16.08	16.46	16.84	kHz					
	9kHz damping	9k							V <sub>38</sub> is monitored by spectrum analyzer to measure level difference between 9kHz and 28kHz relative to 16.46kHz.	—	—	-20	dB
	28kHz damping	28k											
	102.54kHz damping (design guarantee)	102.54k											

## Electrical Characteristics

(V<sub>CC</sub>=5.0V, T<sub>a</sub>=25°C)

Item	Symbol	Condition		Min.	Typ.	Max.	Unit		
46kHz BPF characteristics	F <sub>0</sub> frequency (design guarantee)	F <sub>0</sub> (64k)	S1=2, others=1 SG2; f=100k to 200k, 20mVp-p (SWP time 99sec) V <sub>C21</sub> =V <sub>C23</sub> =5V measuring instru- ment spectrum analyzer Max Hold SCAN 0.2sec	V <sub>31</sub> is monitored by spectrum analyzer to mea- sure frequency giving peak.	45.28	46.20	47.12	kHz	
	33kHz damping	33k			V <sub>31</sub> is monitored by spectrum analyzer to mea- sure level differ- ence between 33kHz and 65kHz relative to 46.26kHz.	—	—	—20	dB
	65kHz damping	65k				—	—	—20	
	102.54kHz damping (design guarantee)	102.54k			V <sub>31</sub> is monitored by spectrum analyzer to mea- sure level differ- ence of 102.54kHz relative to peak.	—	—	—20	
16kHz, 46kHz BPF f <sub>0</sub> gain difference	G	Difference between gain of 16kHz BPF (V <sub>30</sub> ) at 16.46kHz and gain of 46kHz BPF (V <sub>31</sub> ) at 46.20kHz (abso- lute value).		—	—	2	dB		
Subtractor offset	V <sub>OFF</sub>	S1 to S7=1 V <sub>TSA</sub> = V <sub>TSA</sub> = 0.5V, V <sub>SWP</sub> = 1.5V V <sub>36</sub> - V <sub>8</sub> DC difference is measured.		-80	0	80	mV		
Subtractor output voltage (1)	V <sub>36 (1)</sub>	S4=2, others=1	V <sub>36</sub> voltage difference between V <sub>b</sub> =V <sub>32</sub> +30mV and V <sub>b</sub> =V <sub>32</sub> +80mV is measured. *Note 1	-550	500	-430	mV		
Subtractor output voltage (2)	V <sub>36 (2)</sub>		V <sub>36</sub> voltage difference between V <sub>b</sub> =V <sub>32</sub> +30mV and V <sub>b</sub> =V <sub>32</sub> +80mV is measured. *Note 1	400	500	550	mV		

## Electrical Characteristics

(V<sub>CC</sub>=5.0V, T<sub>a</sub>=25°C)

Item	Symbol	Condition		Min.	Typ.	Max.	Unit
Subtractor output voltage (3)	V <sub>36 (3)</sub>	S5=2, others=1	V <sub>36</sub> voltage difference between V <sub>a</sub> =V <sub>33</sub> +30mV and V <sub>a</sub> =V <sub>33</sub> +80mV is measured. *Note 2	400	500	550	mV
Subtractor output voltage (4)	V <sub>36 (4)</sub>		V <sub>36</sub> voltage difference between V <sub>a</sub> =V <sub>33</sub> +30mV and V <sub>a</sub> =V <sub>33</sub> +80mV is measured. *Note 2	-550	-500	-430	mV
Subtractor output voltage (5)	V <sub>36 (5)</sub>		V <sub>36</sub> voltage difference between V <sub>a</sub> =V <sub>32</sub> -30mV and V <sub>b</sub> =V <sub>32</sub> -80mV is measured. Note 1	-110	0	80	mV
Subtractor output voltage (6)	V <sub>36 (6)</sub>		V <sub>36</sub> voltage difference between V <sub>a</sub> =V <sub>32</sub> -30mV and V <sub>b</sub> =V <sub>32</sub> -80mV is measured. *Note 2	-110	0	80	mV
S/HA output voltage	V <sub>S/HA</sub>	V <sub>6</sub> voltage difference between V <sub>b</sub> =V <sub>32</sub> +30mV and V <sub>b</sub> =V <sub>32</sub> +80mV is measured. *Note 1		430	500	600	mV
S/HB output voltage	V <sub>S/HB</sub>	V <sub>35</sub> voltage difference between V <sub>b</sub> =V <sub>32</sub> +30mV and V <sub>b</sub> =V <sub>32</sub> +80mV is measured. *Note 1		430	500	600	mV

**Note 1)** V<sub>32</sub>: Pins 8 and 32 are short-circuited outside.**Note 2)** V<sub>33</sub>: Pins 8 and 33 are short-circuited outside.

## Electrical Characteristics

(V<sub>CC</sub>=5.0V, T<sub>a</sub>=25°C)

Item	Symbol	Condition	Min.	Typ.	Max.	Unit	
Standard voltage	V <sub>REF</sub>	S1 to S7=1 V <sub>8</sub> voltage is measured.	2.4	2.5	2.6	V	
SCF standard voltage	V <sub>RSCF</sub>	S1 to S7=1 V <sub>10</sub> voltage is measured.	—	1.25	—	V	
Ope Amp offset	V' <sub>OFF</sub>	S7=2, others=1 V <sub>8</sub> –V <sub>12</sub> voltage difference is measured.	–10	0	10	mV	
Ope Amp oscillation margin	V' <sub>OSC</sub>	S7=2, others=1 V <sub>12</sub> output noise level	—	—	10	mVp-p	
X'tal OSC	f <sub>X'tal</sub>	S1 to S7=1, f=5.94755 for X'tal V <sub>16</sub> oscillation frequency is measured.	—	5.9	—	MHz	
1/M divider	1/58	S1 to S7=1 V <sub>PB</sub> =1V	V <sub>C23</sub> (SEL1)=5V V <sub>C21</sub> (SEL2)=5V	100	102.5	105	kHz
	1/50		V <sub>C23</sub> (SEL1)=0V V <sub>C21</sub> (SEL2)=5V	116	119.0	122	
	1/36		V <sub>C23</sub> (SEL1)=5V V <sub>C21</sub> (SEL2)=0V	160	165.2	170	
	1/40		V <sub>C23</sub> (SEL1)=0V V <sub>C21</sub> (SEL2)=0V	145	148.7	153	
Pilot signal Out signal	V <sub>24</sub>	S1 to S7=1 V <sub>C23</sub> (SEL1)=5V V <sub>C21</sub> (SEL2)=5V	V <sub>PB</sub> =1V	3.45	3.75	4.15	Vp-p
	V' <sub>24</sub>		V <sub>PB</sub> =3V	—	0	—	
F5 frequency	F <sub>5</sub>	S1 to S7=1, V <sub>F5</sub> Gate=5V	—	228	—	kHz	
F5 Output off level	V <sub>F5</sub>	S1 to S7=1, V <sub>F5</sub> Gate=0V	—	0	—	Vp-p	
Schmitt ON level	V <sub>SMT</sub>	S6=2, others=1 V <sub>PB</sub> =3V, V <sub>TSE</sub> =0.5V While increasing V <sub>C</sub> voltage from 0V, V <sub>35</sub> voltage When V <sub>34</sub> voltage becomes from High to Low is measured.	2.4	2.6	2.8	V	
Schmitt hysteresis	V <sub>HYS</sub>	S1=2, others=1 V <sub>TSE</sub> =0.5V While reducing V <sub>C</sub> voltage from Schmitt ON level voltage, V <sub>35</sub> voltage when V <sub>34</sub> becomes from Low to High is measured, and the level difference from Schmitt ON level is measured.	0.2	0.3	0.4	V	
S/HA Dynamic range	D <sub>S/HA</sub>	S5=2, others=1 V <sub>TSA</sub> =0.5V, V <sub>SWF</sub> =3.5V, V <sub>a</sub> =3.5V V <sub>6</sub> voltage is measured.	4.0	—	—	V	
	D' <sub>S/HA</sub>	S1 to S7=1 V <sub>TSA</sub> =0.5V	—	—	1.3		

\*Note 3



Electrical Characteristics

(V<sub>CC</sub>=5.0V, T<sub>a</sub>=25°C)

Item		Symbol	Condition	Min.	Typ.	Max.	Unit
S/HB Dynamic range	D <sub>S</sub> /HB		S5=2, others=1 V <sub>TSB</sub> =0.5V, V <sub>SWP</sub> =3.5V, V <sub>a</sub> =3.5V V <sub>35</sub> voltage is measured.	4.0	—	—	V
	D' <sub>S</sub> /HB		S1 to S7=1 V <sub>TSB</sub> =0.5V *Note 3	—	—	1.3	
Control circuit	Gate input "H" level	V <sub>IH</sub>	Pins 2, 19, 21, 23 and 37	3.5	—	—	V
	Gate input "L" level	V <sub>IL</sub>	Pins 2, 19, 21, 23 and 37	—	—	1.5	
	Pin 4 input "H" level	V <sub>IH</sub>	Pin 4	3.5	—	—	V
	Pin 4 input "L" level	V <sub>IL</sub>	Pin 4	—	—	1.0	
	PB operation quarantee voltage	V <sub>R/P</sub>	S1 to S7=1 While increasing V <sub>PB</sub> from 0V, V <sub>PB</sub> voltage when current of ammeter ① is switched over from Low to High is measured.	3.5	—	—	
Tracking variable range		V <sub>T</sub>	S3=2, others=1 While changing V <sub>TRAX</sub> from 0V to 5V, voltage difference at 36 pin output at this point is measured.	1.45	1.75	1.95	V
"H" level Input current		I <sub>IH</sub>	Pins 2, 19, 21, 23 and 37 V <sub>IH</sub> =5.0V	-1	0	1	μA
	"L" level	I <sub>IL</sub>	Pins 2, 19, 21, 23 and 37 V <sub>IL</sub> =0.0V	-1	0	1	μA
Output current	"H" level	I <sub>OH</sub>	Pin 20 V <sub>OH</sub> =4.6V	0.35	0.8	—	mA
	"L" level	I <sub>OL</sub>	Pin 20 V <sub>OL</sub> =0.4V	0.35	0.8	—	

\*Note 3) The following triangular wave is entered from Pin 36.

While monitoring Pins 6 and 35 with an oscilloscope, D'S/HA and D'S/HB when output waveform becomes an follows are measured.

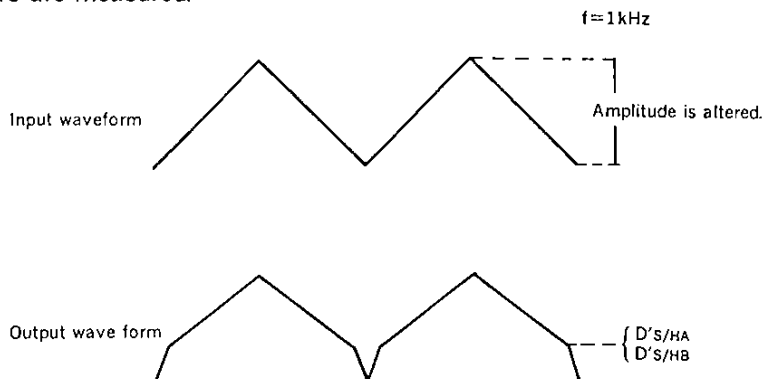

Test Circuit

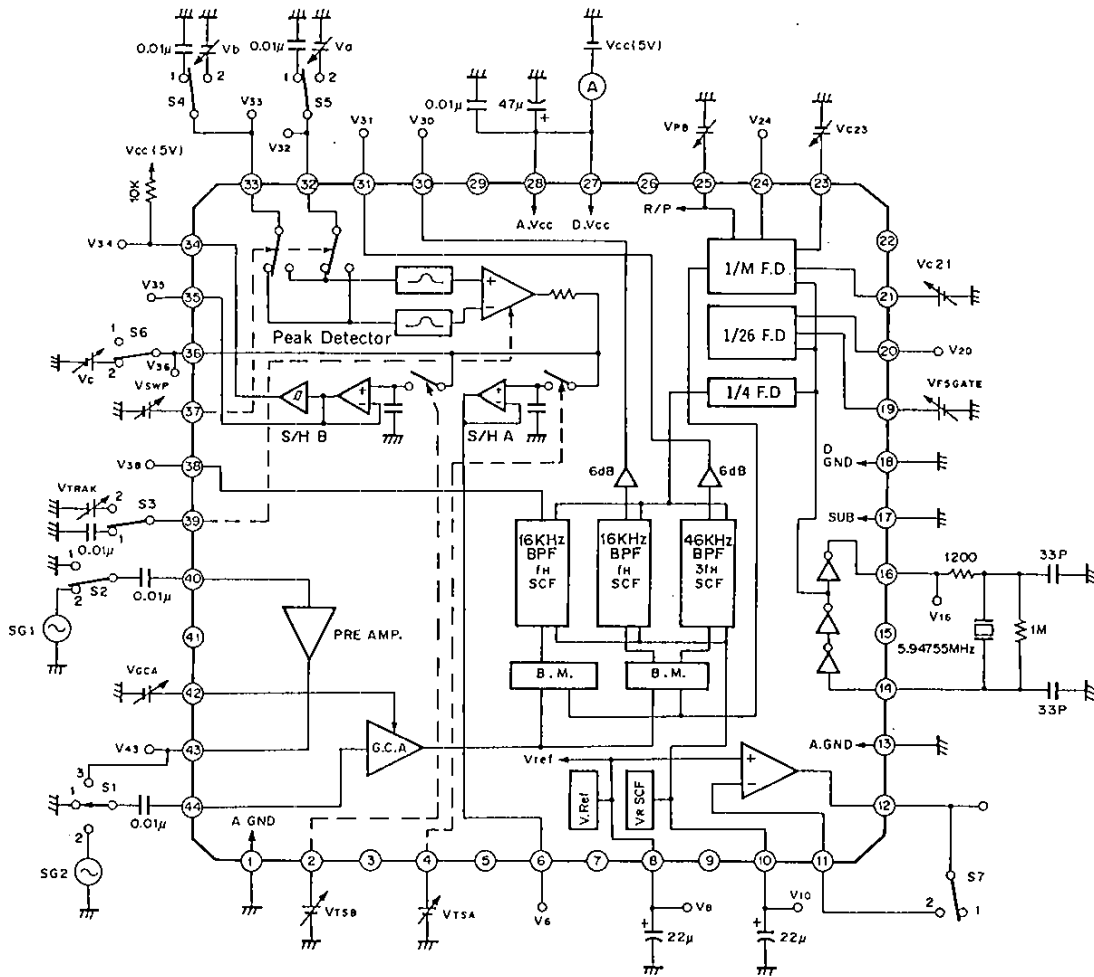

**Note)** When there is no particular specification of test condition, control voltage is measured under the following conditions.

$$V_{TSA} = V_{TSB} = V_{F5GATE} = V_{C21} = V_{C23} = V_{SWP} = 0V$$

$$V_a = V_b = V_c = 2.5V$$

$$V_{GCA} = 3.2V$$

$$V_{PB} = 3.5V$$

Application Circuit

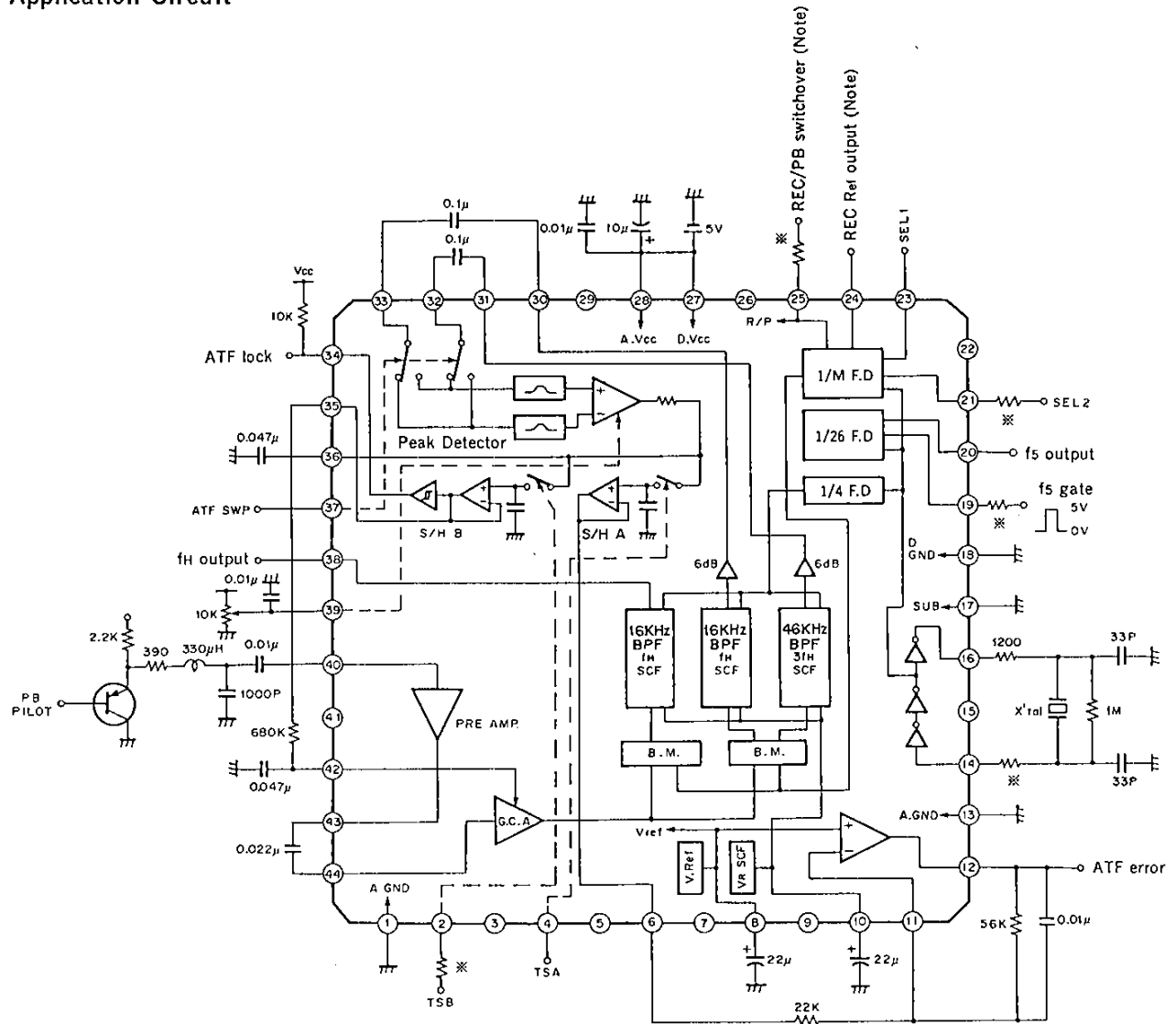

Resistance marked\* is for protection.

Note)

SEL1	SEL2	REC Ref output	Dividing ratio
H	H	f <sub>1</sub>	1/58
L	H	f <sub>2</sub>	1/50
H	L	f <sub>3</sub>	1/36
L	L	f <sub>4</sub>	1/40

Application circuits shown are typical examples illustrating the operation of the devices. Sony cannot assume responsibility for any problems arising out of the use of these circuits or for any infringement of third party patent and other right due to same.