

# MC1489, A

## Quad Line Receivers

The MC1489 monolithic quad line receivers are designed to interface data terminal equipment with data communications equipment in conformance with the specifications of EIA Standard No. EIA-232D.

- Input Resistance – 3.0 k to 7.0 k $\Omega$
- Input Signal Range –  $\pm 30$  V
- Input Threshold Hysteresis Built In
- Response Control
  - a) Logic Threshold Shifting
  - b) Input Noise Filtering

**QUAD MDTL  
LINE RECEIVERS  
EIA-232D  
SEMICONDUCTOR  
TECHNICAL DATA**

### ORDERING INFORMATION

Device	Operating Temperature Range	Package
MC1489P, AP	$T_A = 0$ to $+75^\circ\text{C}$	Plastic
MC1489D, AD		SO-14

**P SUFFIX  
PLASTIC PACKAGE  
CASE 646**

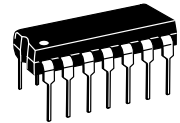

**D SUFFIX  
PLASTIC PACKAGE  
CASE 751A  
(SO-14)**

### Simplified Application

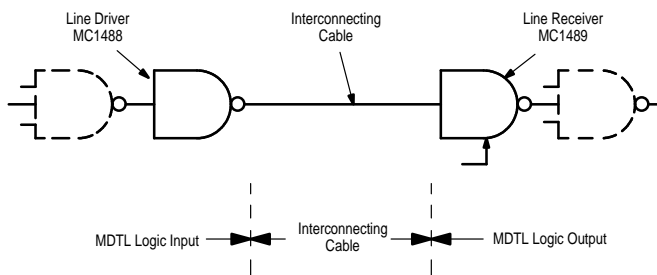

### PIN CONNECTIONS

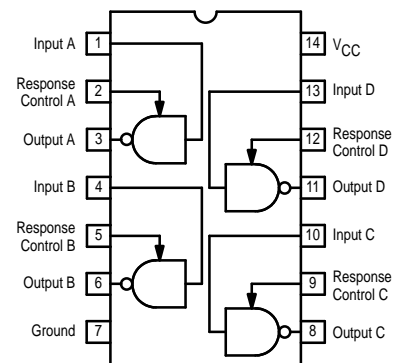

### Representative Schematic Diagram (1/4 of Circuit Shown)

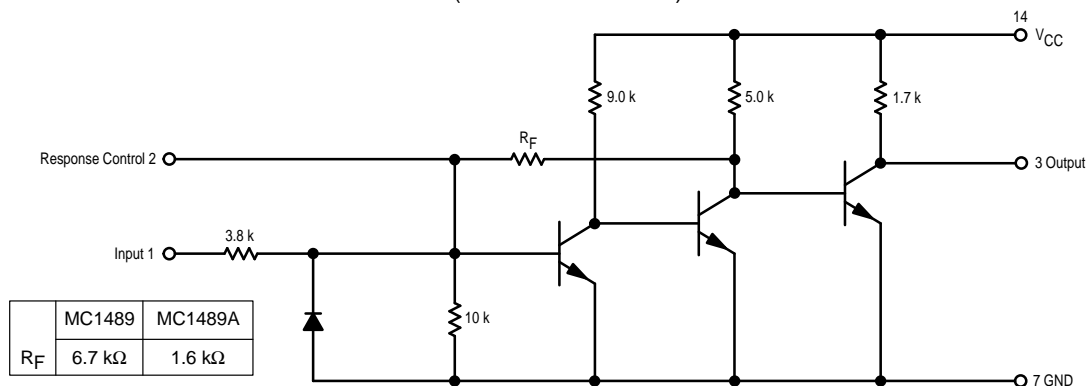

# MC1489, A

## MAXIMUM RATINGS (T<sub>A</sub> = + 25°C, unless otherwise noted)

Rating	Symbol	Value	Unit
Power Supply Voltage	V <sub>CC</sub>	10	Vdc
Input Voltage Range	V <sub>IR</sub>	± 30	Vdc
Output Load Current	I <sub>L</sub>	20	mA
Power Dissipation (Package Limitation, SO-14 and Plastic Dual In-Line Package) Derate above T <sub>A</sub> = + 25°C	P <sub>D</sub> 1/θ <sub>JA</sub>	1000 6.7	mW mW/°C
Operating Ambient Temperature Range	T <sub>A</sub>	0 to + 75	°C
Storage Temperature Range	T <sub>stg</sub>	- 65 to + 175	°C

## ELECTRICAL CHARACTERISTICS (Response control pin is open.) (V<sub>CC</sub> = + 5.0 Vdc ± 10%, T<sub>A</sub> = 0 to + 75°C, unless otherwise noted)

Characteristics	Symbol	Min	Typ	Max	Unit
Positive Input Current (V <sub>IH</sub> = + 25 Vdc) (V <sub>IH</sub> = + 3.0 Vdc)	I <sub>IH</sub>	3.6 0.43	- -	8.3 -	mA
Negative Input Current (V <sub>IH</sub> = - 25 Vdc) (V <sub>IH</sub> = - 3.0 Vdc)	I <sub>IL</sub>	- 3.6 - 0.43	- -	- 8.3 -	mA
Input Turn-On Threshold Voltage (T <sub>A</sub> = + 25°C, V <sub>OL</sub> ≤ 0.45 V)	V <sub>IH</sub>	1.0 1.75	- 1.95	1.5 2.25	Vdc
Input Turn-Off Threshold Voltage (T <sub>A</sub> = + 25°C, V <sub>OH</sub> ≥ 2.5 V, I <sub>L</sub> = - 0.5 mA)	V <sub>IL</sub>	0.75 0.75	- 0.8	1.25 1.25	Vdc
Output Voltage High (V <sub>IH</sub> = 0.75 V, I <sub>L</sub> = - 0.5 mA) (Input Open Circuit, I <sub>L</sub> = - 0.5 mA)	V <sub>OH</sub>	2.5 2.5	4.0 4.0	5.0 5.0	Vdc
Output Voltage Low (V <sub>IL</sub> = 3.0 V, I <sub>L</sub> = 10 mA)	V <sub>OL</sub>	-	0.2	0.45	Vdc
Output Short-Circuit Current	I <sub>OS</sub>	-	- 3.0	- 4.0	mA
Power Supply Current (All Gates "on," I <sub>out</sub> = 0 mA, V <sub>IH</sub> = + 5.0 Vdc)	I <sub>CC</sub>	-	16	26	mA
Power Consumption (V <sub>IH</sub> = + 5.0 Vdc)	P <sub>C</sub>	-	80	130	mW

## SWITCHING CHARACTERISTICS (V<sub>CC</sub> = 5.0 Vdc ± 1%, T<sub>A</sub> = + 25°C, See Figure 1.)

Propagation Delay Time (R <sub>L</sub> = 3.9 kΩ)	t <sub>PLH</sub>	-	25	85	ns
Rise Time (R <sub>L</sub> = 3.9 kΩ)	t <sub>TLH</sub>	-	120	175	ns
Propagation Delay Time (R <sub>L</sub> = 390 kΩ)	t <sub>PHL</sub>	-	25	50	ns
Fall Time (R <sub>L</sub> = 390 kΩ)	t <sub>THL</sub>	-	10	20	ns

## TEST CIRCUITS

Figure 1. Switching Response

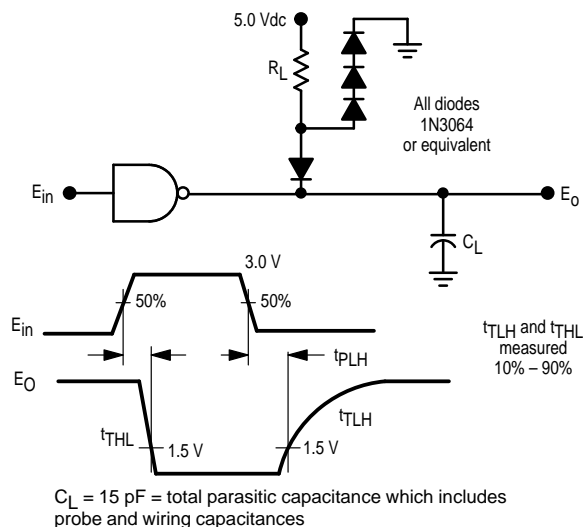
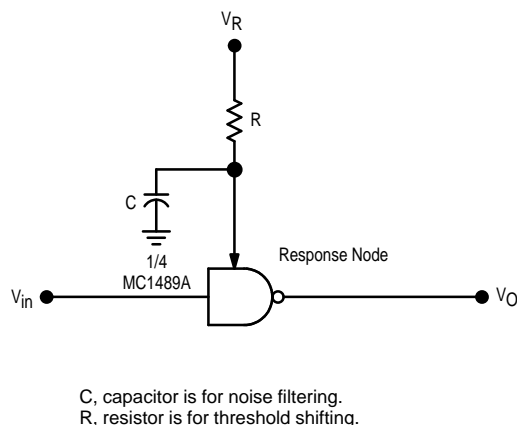

Figure 2. Response Control Node



# MC1489, A

## TYPICAL CHARACTERISTICS

( $V_{CC} = 5.0 \text{ Vdc}$ ,  $T_A = +25^\circ\text{C}$ , unless otherwise noted)

Figure 3. Input Current

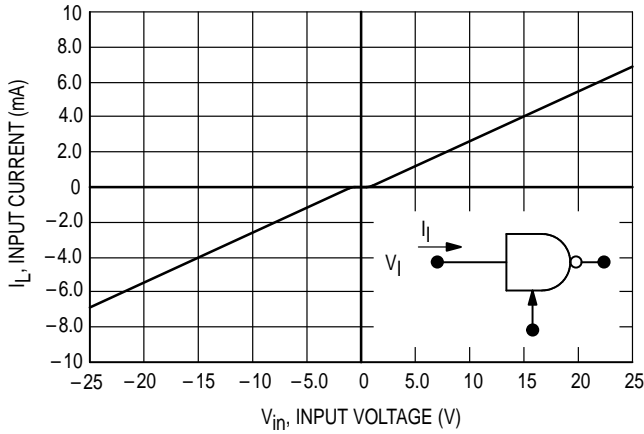

Figure 4. MC1489 Input Threshold Voltage Adjustment

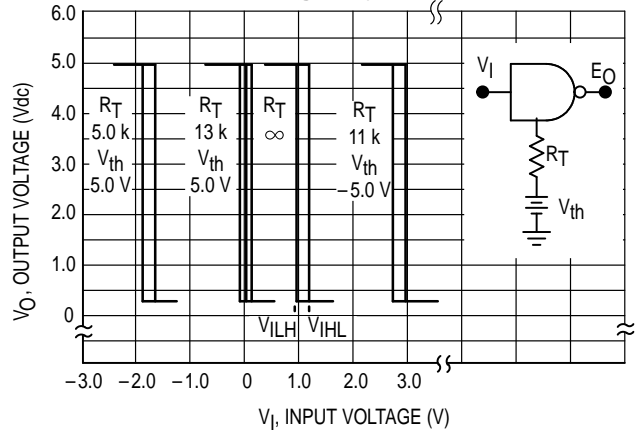

Figure 5. MC1489A Input Threshold Voltage Adjustment

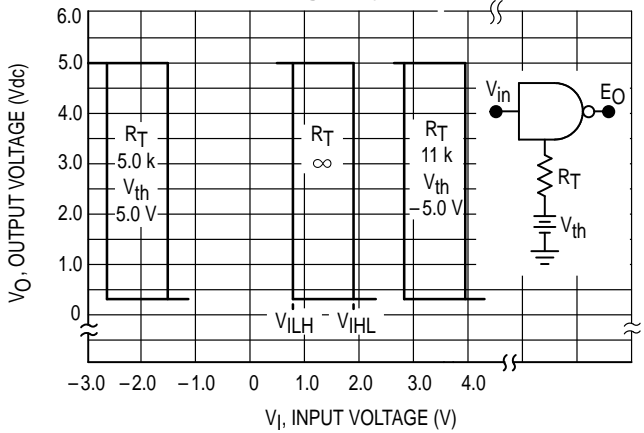

Figure 6. Input Threshold Voltage versus Temperature

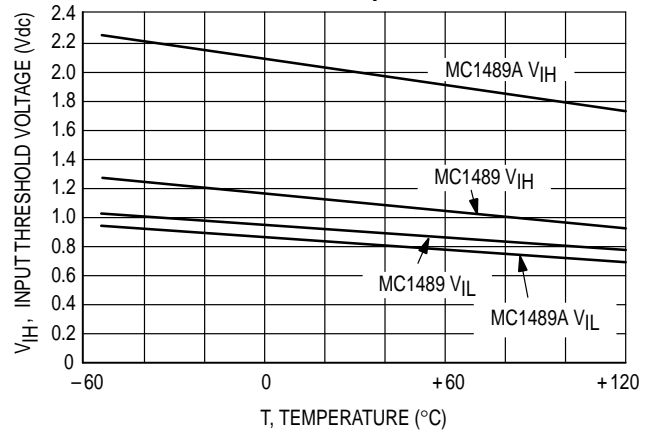
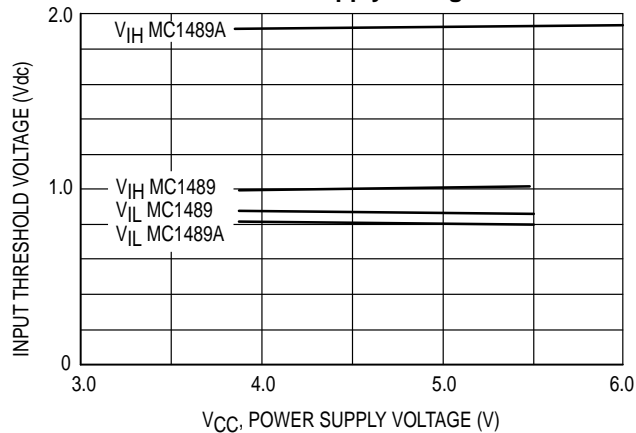

Figure 7. Input Threshold versus Power Supply Voltage



## APPLICATIONS INFORMATION

## General Information

The Electronic Industries Association (EIA) has released the EIA-232D specification detailing the requirements for the interface between data processing equipment and data communications equipment. This standard specifies not only the number and type of interface leads, but also the voltage levels to be used. The MC1488 quad driver and its companion circuit, the MC1489 quad receiver, provide a complete interface system between DTL or TTL logic levels and the EIA-232D defined levels. The EIA-232D requirements as applied to receivers are discussed herein.

The required input impedance is defined as between 3000  $\Omega$  and 7000  $\Omega$  for input voltages between 3.0 and 25 V in magnitude; and any voltage on the receiver input in an open circuit condition must be less than 2.0 V in magnitude. The MC1489 circuits meet these requirements with a maximum open circuit voltage of one  $V_{BE}$ .

The receiver shall detect a voltage between - 3.0 and - 25 V as a Logic "1" and inputs between 3.0 and 25 V as a Logic "0." On some interchange leads, an open circuit of power "OFF" condition (300  $\Omega$  or more to ground) shall be decoded as an "OFF" condition or Logic "1." For this reason, the input hysteresis thresholds of the MC1489 circuits are all above ground. Thus an open or grounded input will cause the same output as a negative or Logic "1" input.

## Device Characteristics

The MC1489 interface receivers have internal feedback from the second stage to the input stage providing input hysteresis for noise rejection. The MC1489 input has typical

turn-on voltage of 1.25 V and turn-off of 1.0 V for a typical hysteresis of 250 mV. The MC1489A has typical turn-on of 1.95 V and turn-off of 0.8 V for typically 1.15 V of hysteresis.

Each receiver section has an external response control node in addition to the input and output pins, thereby allowing the designer to vary the input threshold voltage levels. A resistor can be connected between this node and an external power supply. Figures 2, 4 and 5 illustrate the input threshold voltage shift possible through this technique.

This response node can also be used for the filtering of high frequency, high energy noise pulses. Figures 8 and 9 show typical noise pulse rejection for external capacitors of various sizes.

These two operations on the response node can be combined or used individually for many combinations of interfacing applications. The MC1489 circuits are particularly useful for interfacing between MOS circuits and MDTL/MTTL logic systems. In this application, the input threshold voltages are adjusted (with the appropriate supply and resistor values) to fall in the center of the MOS voltage logic levels (see Figure 10).

The response node may also be used as the receiver input as long as the designer realizes that he may not drive this node with a low impedance source to a voltage greater than one diode above ground or less than one diode below ground. This feature is demonstrated in Figure 11 where two receivers are slaved to the same line that must still meet the EIA-232D impedance requirement.

Figure 8. Typical Turn On Threshold versus Capacitance from Response Control Pin to GND

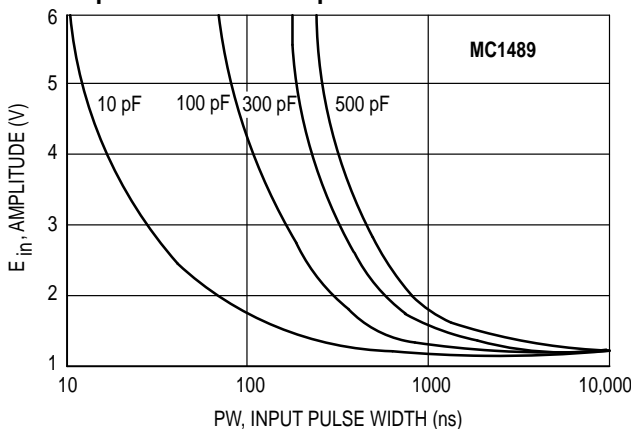
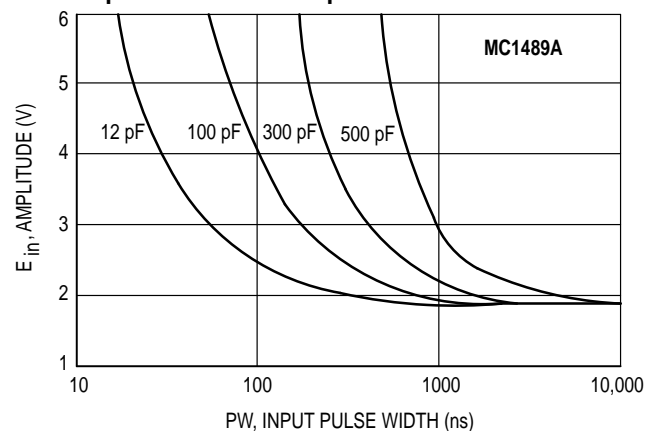

Figure 9. Typical Turn On Threshold versus Capacitance from Response Control Pin to GND



# MC1489, A

Figure 10. Typical Translator Application – MOS to DTL or TTL

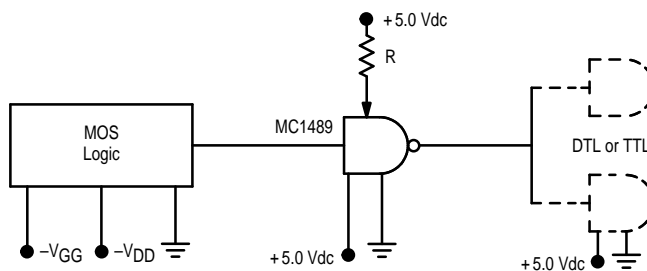
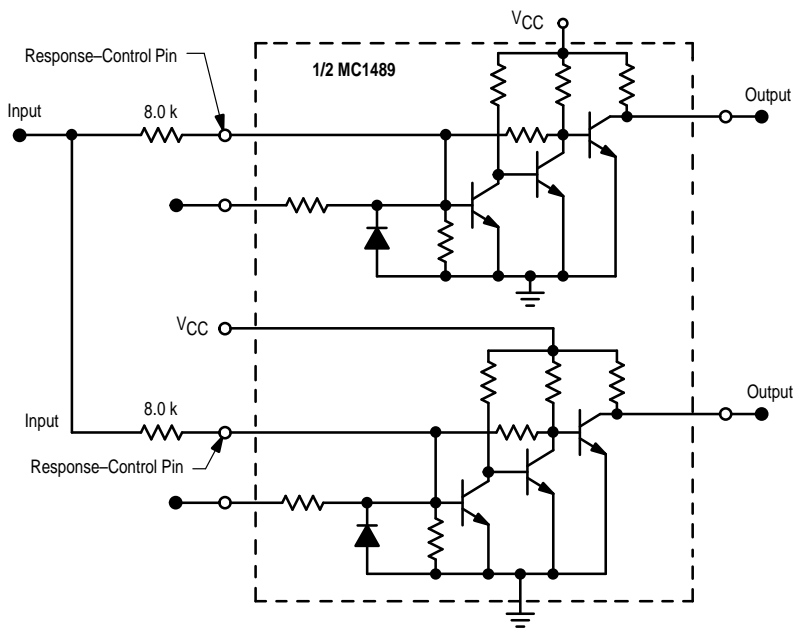

Figure 11. Typical Paralleling of Two MC1489, A Receivers to Meet EIA-232D



# MC1489, A

## OUTLINE DIMENSIONS

### P SUFFIX PLASTIC PACKAGE CASE 646-06 ISSUE L

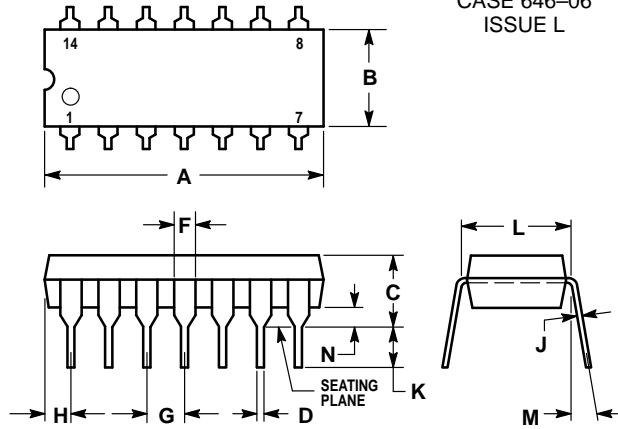

NOTES:

- LEADS WITHIN 0.13 (0.005) RADIUS OF TRUE POSITION AT SEATING PLANE AT MAXIMUM MATERIAL CONDITION.
- DIMENSION L TO CENTER OF LEADS WHEN FORMED PARALLEL.
- DIMENSION B DOES NOT INCLUDE MOLD FLASH.
- ROUNDED CORNERS OPTIONAL.

DIM	INCHES		MILLIMETERS	
	MIN	MAX	MIN	MAX
A	0.715	0.770	18.16	19.56
B	0.240	0.260	6.10	6.60
C	0.145	0.185	3.69	4.69
D	0.015	0.021	0.38	0.53
F	0.040	0.070	1.02	1.78
G	0.100 BSC		2.54 BSC	
H	0.052	0.095	1.32	2.41
J	0.008	0.015	0.20	0.38
K	0.115	0.135	2.92	3.43
L	0.300 BSC		7.62 BSC	
M	0°	10°	0°	10°
N	0.015	0.039	0.39	1.01

### D SUFFIX PLASTIC PACKAGE CASE 751A-03 (SO-14) ISSUE F

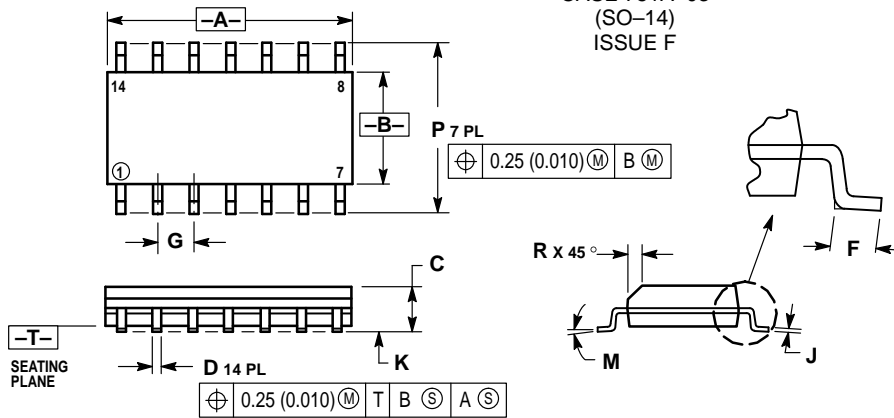

NOTES:

- DIMENSIONING AND TOLERANCING PER ANSI Y14.5M, 1982.
- CONTROLLING DIMENSION: MILLIMETER.
- DIMENSIONS A AND B DO NOT INCLUDE MOLD PROTRUSION.
- MAXIMUM MOLD PROTRUSION 0.15 (0.006) PER SIDE.
- DIMENSION D DOES NOT INCLUDE DAMBAR PROTRUSION. ALLOWABLE DAMBAR PROTRUSION SHALL BE 0.127 (0.005) TOTAL IN EXCESS OF THE D DIMENSION AT MAXIMUM MATERIAL CONDITION.

DIM	MILLIMETERS		INCHES	
	MIN	MAX	MIN	MAX
A	8.55	8.75	0.337	0.344
B	3.80	4.00	0.150	0.157
C	1.35	1.75	0.054	0.068
D	0.35	0.49	0.014	0.019
F	0.40	1.25	0.016	0.049
G	1.27 BSC		0.050 BSC	
J	0.19	0.25	0.008	0.009
K	0.10	0.25	0.004	0.009
M	0°	7°	0°	7°
P	5.80	6.20	0.228	0.244
R	0.25	0.50	0.010	0.019

Motorola reserves the right to make changes without further notice to any products herein. Motorola makes no warranty, representation or guarantee regarding the suitability of its products for any particular purpose, nor does Motorola assume any liability arising out of the application or use of any product or circuit, and specifically disclaims any and all liability, including without limitation consequential or incidental damages. "Typical" parameters can and do vary in different applications. All operating parameters, including "Typicals" must be validated for each customer application by customer's technical experts. Motorola does not convey any license under its patent rights nor the rights of others. Motorola products are not designed, intended, or authorized for use as components in systems intended for surgical implant into the body, or other applications intended to support or sustain life, or for any other application in which the failure of the Motorola product could create a situation where personal injury or death may occur. Should Buyer purchase or use Motorola products for any such unintended or unauthorized application, Buyer shall indemnify and hold Motorola and its officers, employees, subsidiaries, affiliates, and distributors harmless against all claims, costs, damages, and expenses, and reasonable attorney fees arising out of, directly or indirectly, any claim of personal injury or death associated with such unintended or unauthorized use, even if such claim alleges that Motorola was negligent regarding the design or manufacture of the part. Motorola and are registered trademarks of Motorola, Inc. Motorola, Inc. is an Equal Opportunity/Affirmative Action Employer.

**How to reach us:**

**USA/EUROPE:** Motorola Literature Distribution;  
P.O. Box 20912; Phoenix, Arizona 85036. 1-800-441-2447

**JAPAN:** Nippon Motorola Ltd.; Tatsumi-SPD-JLDC, Toshikatsu Otsuki,  
6F Seibu-Butsuryu-Center, 3-14-2 Tatsumi Koto-Ku, Tokyo 135, Japan. 03-3521-8315

**MFAX:** RMFAX0@email.sps.mot.com - TOUCHTONE (602) 244-6609  
**INTERNET:** http://Design-NET.com

**HONG KONG:** Motorola Semiconductors H.K. Ltd.; 8B Tai Ping Industrial Park,  
51 Ting Kok Road, Tai Po, N.T., Hong Kong. 852-26629298



MC1489/D

